



KSZ8081MLX

10Base-T/100Base-TX Physical Layer Transceiver

Revision 1.2

General Description

The KSZ8081MLX is a single-supply 10Base-T/100Base-TX Ethernet physical-layer transceiver for transmission and reception of data over standard CAT-5 unshielded twisted pair (UTP) cable.

The KSZ8081MLX is a highly-integrated, compact solution. It reduces board cost and simplifies board layout by using on-chip termination resistors for the differential pairs, by integrating a low-noise regulator to supply the 1.2V core, and by offering 1.8/2.5/3.3V digital I/O interface support.

The KSZ8081MLX offers the Media Independent Interface (MII) for direct connection with MII-compliant Ethernet MAC processors and switches.

The KSZ8081MLX provides diagnostic features to facilitate system bring-up and debugging in production testing and in product deployment. Parametric NAND tree support enables fault detection between KSZ8081MLX I/Os and the board. Micrel LinkMD[®] TDR-based cable diagnostics identify faulty copper cabling.

The KSZ8081MLX is available in the 48-pin, lead-free LQFP package (see [Ordering Information](#)).

Datasheets and support documentation are available on Micrel's web site at: www.micrel.com.

Features

- Single-chip 10Base-T/100Base-TX IEEE 802.3 compliant Ethernet transceiver
- MII interface support
- Back-to-back mode support for 100Mbps copper repeater
- MDC/MDIO management interface for PHY register configuration
- Programmable interrupt output
- LED outputs for link, activity, and speed status indication
- On-chip termination resistors for the differential pairs
- Baseline wander correction
- HP Auto MDI/MDI-X to reliably detect and correct straight-through and crossover cable connections with disable and enable option
- Auto-negotiation to automatically select the highest link-up speed (10/100Mbps) and duplex (half/full)
- Power-down and power-saving modes
- LinkMD TDR-based cable diagnostics to identify faulty copper cabling
- Parametric NAND Tree support for fault detection between chip I/Os and the board

Functional Diagram

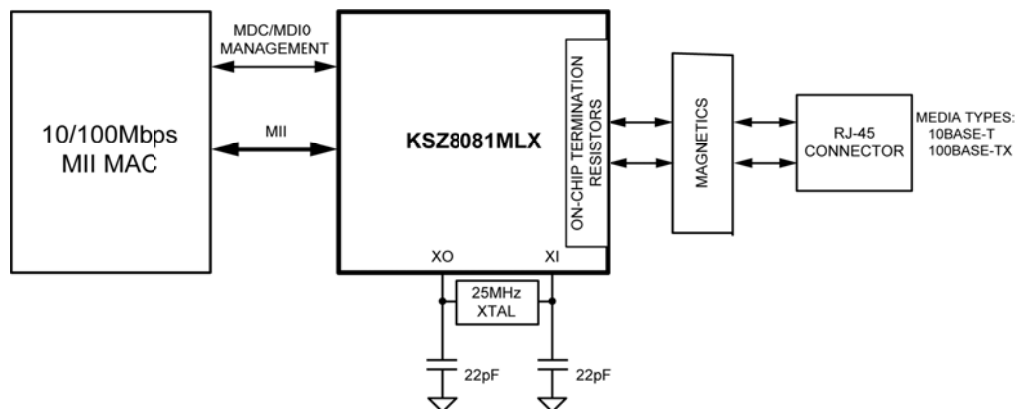

LinkMD is a registered trademark of Micrel, Inc.

Micrel Inc. • 2180 Fortune Drive • San Jose, CA 95131 • USA • tel +1 (408) 944-0800 • fax + 1 (408) 474-1000 • <http://www.micrel.com>

Features (Continued)

- Loopback modes for diagnostics
- Single 3.3V power supply with VDD I/O options for 1.8V, 2.5V, or 3.3V
- Built-in 1.2V regulator for core
- Available in 48-pin 7mm x 7mm LQFP package

Applications

- Game consoles
- IP phones
- IP set-top boxes
- IP TVs
- LOM
- Printers

Ordering Information

For the device marking (second column in the following table), the fifth character of line three indicates whether the device has gold wire bonding or silver wire bonding, as follows:

- Gold wire bonding: The Letter “S” is not present as the fifth character of line 3.
- Silver wire bonding: The Letter “S” is present as the fifth character of line 3.

For line three, the presence or lack of the letter “S” is preceded by YYWW, indicating the last two digits of the year and the two digits work week for the chip date code, and is followed by xxx, indicating the chip revision and assembly site.

Ordering Part Number	Device Marking	Temperature Range	Wire Bonding	Description
KSZ8081MLXCA	KSZ8081 MLXCA YYWWxxx	0°C to 70°C	Gold	MII, Commercial Temperature, Gold Wire Bonding, 48-Pin LQFP, Pb-Free
SPNZ801136 ⁽¹⁾	KSZ8081 MLXCA YYWWSxxx	0°C to 70°C	Silver	MII, Commercial Temperature, Silver Wire Bonding, 48-Pin LQFP, Pb-Free
KSZ8081MLXIA ⁽¹⁾	KSZ8081 MLXIA YYWWxxx	-40°C to 85°C	Gold	MII, Industrial Temperature, Gold Wire Bonding, 48-Pin LQFP, Pb-Free
SPNY801136 ⁽¹⁾	KSZ8081 MLXIA YYWWSxxx	-40°C to 85°C	Silver	MII, Industrial Temperature, Silver Wire Bonding, 48-Pin LQFP, Pb-Free
KSZ8081MLX-EVAL				KSZ8081MLX Evaluation Board (Mounted with KSZ8081MLX device in commercial temperature)

Note:

1. Contact factory for availability.

Revision History

Date	Summary of Changes	Revision
11/5/12	Initial release of new product datasheet.	1.0
2/6/14	Removed copper-wire bonding part numbers from Ordering Information. Added note for TXC (Pin 33) and Register 16h, Bit [15] regarding a Reserved Factory Mode. Removed TXC and RXC clock connections for MII Back-to-Back mode. This is a datasheet correction. There is no change to the silicon. Added series resistance and load capacitance for the crystal selection criteria.	1.1
11/25/14	Added silver-wire bonding part numbers to Ordering Information. Updated Ordering Information to include Ordering Part Number and Device Marking.	1.2

Contents

List of Figures.....	6
List of Tables.....	7
Pin Configuration.....	8
Pin Description.....	9
Strapping Options.....	12
Functional Description: 10Base-T/100Base-TX Transceiver.....	14
100Base-TX Transmit.....	14
100Base-TX Receive.....	14
Scrambler/De-Scrambler (100Base-TX Only).....	14
10Base-T Transmit.....	14
10Base-T Receive.....	15
SQE and Jabber Function (10Base-T Only).....	15
PLL Clock Synthesizer.....	15
Auto-Negotiation.....	15
MII Interface.....	17
MII Signal Definition.....	17
Transmit Clock (TXC).....	17
Transmit Enable (TXEN).....	17
Transmit Data[3:0] (TXD[3:0]).....	18
Receive Clock (RXC).....	18
Receive Data Valid (RXDV).....	18
Receive Data[3:0] (RXD[3:0]).....	18
Receive Error (RXER).....	18
Carrier Sense (CRS).....	18
Collision (COL).....	18
MII Signal Diagram.....	18
Back-to-Back Mode – 100Mbps Copper Repeater.....	20
MII Back-to-Back Mode.....	20
MII Management (MIIM) Interface.....	21
Interrupt (INTRP).....	21
HP Auto MDI/MDI-X.....	21
Straight Cable.....	22
Crossover Cable.....	22
Loopback Mode.....	23
Local (Digital) Loopback.....	23
Remote (Analog) Loopback.....	24
LinkMD [®] Cable Diagnostic.....	26
NAND Tree Support.....	26
NAND Tree I/O Testing.....	27

Power Management	28
Power-Saving Mode	28
Energy-Detect Power-Down Mode	28
Power-Down Mode	28
Slow-Oscillator Mode	28
Reference Circuit for Power and Ground Connections	29
Typical Current/Power Consumption	30
Register Map	32
Register Description	33
Absolute Maximum Ratings	43
Operating Ratings	43
Electrical Characteristics	43
Timing Diagrams	45
MII SQE Timing (10Base-T)	45
MII Transmit Timing (10Base-T)	46
MII Receive Timing (10Base-T)	47
MII Transmit Timing (100Base-TX)	48
MII Receive Timing (100Base-TX)	49
Auto-Negotiation Timing	50
MDC/MDIO Timing	51
Power-Up/Reset Timing	52
Reset Circuit	53
Reference Circuits – LED Strap-In Pins	54
Reference Clock – Connection and Selection	55
Magnetic – Connection and Selection	56
Package Information and Recommended Landing Pattern	58

List of Figures

Figure 1. Auto-Negotiation Flow Chart.....	16
Figure 2. KSZ8081MLX MII Interface	19
Figure 3. KSZ8081MLX to KSZ8081MLX Back-to-Back Copper Repeater.....	20
Figure 4. Typical Straight Cable Connection	22
Figure 5. Typical Crossover Cable Connection	23
Figure 6. Local (Digital) Loopback	24
Figure 7. Remote (Analog) Loopback	25
Figure 8. KSZ8081MLX Power and Ground Connections	29
Figure 9. MII SQE Timing (10Base-T)	45
Figure 10. MII Transmit Timing (10Base-T).....	46
Figure 11. MII Receive Timing (10Base-T).....	47
Figure 12. MII Transmit Timing (100Base-TX).....	48
Figure 13. MII Receive Timing (100Base-TX).....	49
Figure 14. Auto-Negotiation Fast Link Pulse (FLP) Timing	50
Figure 15. MDC/MDIO Timing.....	51
Figure 16. Power-Up/Reset Timing.....	52
Figure 17. Recommended Reset Circuit.....	53
Figure 18. Recommended Reset Circuit for Interfacing with CPU/FPGA Reset Output	53
Figure 19. Reference Circuits for LED Strapping Pins	54
Figure 20. 25MHz Crystal/Oscillator Reference Clock Connection	55
Figure 21. Typical Magnetic Interface Circuit.....	56

List of Tables

Table 1. MII Signal Definition	17
Table 2. MII Signal Connection for MII Back-to-Back Mode (100Base-TX Copper Repeater).....	20
Table 3. MII Management Frame Format for the KSZ8081MLX	21
Table 4. MDI/MDI-X Pin Definition	22
Table 5. NAND Tree Test Pin Order for KSZ8081MLX	27
Table 6. KSZ8081 Power Pin Description.....	29
Table 7. Typical Current/Power Consumption (VDDA_3.3 = 3.3V, VDDIO = 3.3V).....	30
Table 8. Typical Current/Power Consumption (VDDA_3.3 = 3.3V, VDDIO = 2.5V).....	30
Table 9. Typical Current/Power Consumption (VDDA_3.3 = 3.3V, VDDIO = 1.8V).....	31
Table 10. MII SQE Timing (10Base-T) Parameters	45
Table 11. MII Transmit Timing (10Base-T) Parameters	46
Table 12. MII Receive Timing (10Base-T) Parameters	47
Table 13. MII Transmit Timing (100Base-TX) Parameters	48
Table 14. MII Receive Timing (100Base-TX) Parameters	49
Table 15. Auto-Negotiation Fast Link Pulse (FLP) Timing Parameters.....	50
Table 16. MDC/MDIO Timing Parameters	51
Table 17. Power-Up/Reset Timing Parameters	52
Table 18. 25MHz Crystal / Reference Clock Selection Criteria	55
Table 19. Magnetics Selection Criteria	57
Table 20. Compatible Single-Port 10/100 Magnetics	57

Pin Configuration

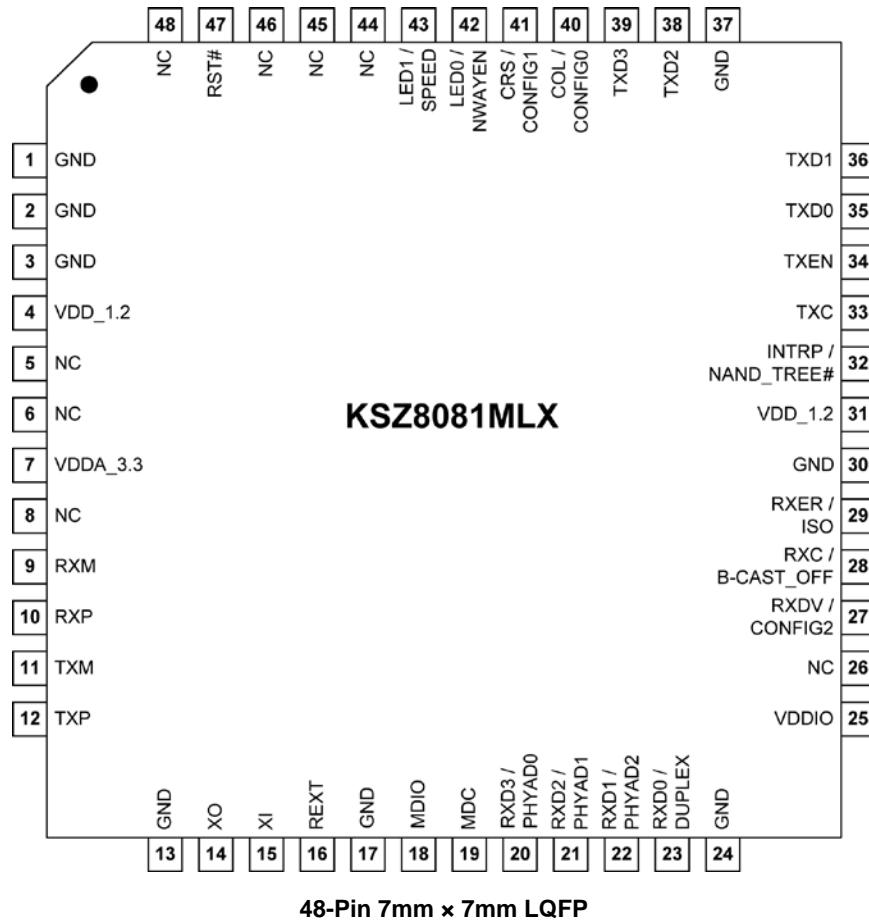

Pin Description

Pin Number	Pin Name	Type ⁽²⁾	Pin Function
1	GND	GND	Ground.
2	GND	GND	Ground.
3	GND	GND	Ground.
4	VDD_1.2	P	1.2V Core V _{DD} (power supplied by KSZ8081MLX). Decouple with 2.2μF and 0.1μF capacitors to ground, and join with Pin 31 by power trace or plane.
5	NC	–	No Connect. This pin is not bonded and can be left floating.
6	NC	–	No Connect. This pin is not bonded and can be left floating.
7	VDDA_3.3	P	3.3V Analog V _{DD} .
8	NC	–	No Connect. This pin is not bonded and can be left floating.
9	RXM	I/O	Physical Receive or Transmit Signal (– differential).
10	RXP	I/O	Physical Receive or Transmit Signal (+ differential).
11	TXM	I/O	Physical Transmit or Receive Signal (– differential).
12	TXP	I/O	Physical Transmit or Receive Signal (+ differential).
13	GND	Gnd	Ground.
14	XO	O	Crystal Feedback for 25MHz Crystal. This pin is a no connect if an oscillator or external clock source is used.
15	XI	I	Crystal / Oscillator / External Clock Input (25MHz ±50ppm).
16	REXT	I	Set PHY Transmit Output Current. Connect a 6.49kΩ resistor to ground on this pin.
17	GND	GND	Ground.
18	MDIO	Ipu/Opu	Management Interface (MII) Data I/O. This pin has a weak pull-up, is open-drain, and requires an external 1.0kΩ pull-up resistor.
19	MDC	Ipu	Management Interface (MII) Clock Input. This clock pin is synchronous to the MDIO data pin.
20	RXD3/ PHYAD0	Ipu/O	MII Mode: MII Receive Data Output[3] ⁽³⁾ Config. Mode: The pull-up/pull-down value is latched as PHYADDR[0] at the de-assertion of reset. See the Strapping Options section for details.
21	RXD2/ PHYAD1	Ipd/O	MII Mode: MII Receive Data Output[2] ⁽³⁾ Config. Mode: The pull-up/pull-down value is latched as PHYADDR[1] at the de-assertion of reset. See the Strapping Options section for details.

Notes:

- P = Power supply.
 GND = Ground.
 I = Input.
 O = Output.
 I/O = Bi-directional.
 Ipu = Input with internal pull-up (see [Electrical Characteristics](#)⁽⁹⁾ for value).
 Ipd = Input with internal pull-down (see [Electrical Characteristics](#)⁽⁹⁾ for value).
 Ipu/O = Input with internal pull-up (see [Electrical Characteristics](#)⁽⁹⁾ for value) during power-up/reset; output pin otherwise.
 Ipd/O = Input with internal pull-down (see [Electrical Characteristics](#)⁽⁹⁾ for value) during power-up/reset; output pin otherwise.
 Ipu/Opu = Input with internal pull-up (see [Electrical Characteristics](#)⁽⁹⁾ for value) and output with internal pull-up (see [Electrical Characteristics](#)⁽⁹⁾ for value).
- MII RX Mode: The RXD[3:0] bits are synchronous with RXC. When RXDV is asserted, RXD[3:0] presents valid data to the MAC.

Pin Description (Continued)

Pin Number	Pin Name	Type ⁽²⁾	Pin Function
22	RXD1/ PHYAD2	lpd/O	MII Mode: MII Receive Data Output[1] ⁽³⁾ . Config. Mode: The pull-up/pull-down value is latched as PHYADDR[2] at the de-assertion of reset. See the Strapping Options section for details.
23	RXD0/ DUPLEX	lpu/O	MII Mode: MII Receive Data Output[0] ⁽³⁾ . Config. Mode: The pull-up/pull-down value is latched as DUPLEX at the de-assertion of reset. See the Strapping Options section for details.
24	GND	Gnd	Ground.
25	VDDIO	P	3.3V, 2.5V, or 1.8V Digital V _{DD} .
26	NC	-	No Connect. This pin is not bonded and can be left floating.
27	RXDV/ CONFIG2	lpd/O	MII Mode: MII Receive Data Valid Output. Config. Mode: The pull-up/pull-down value is latched as CONFIG2 at the de-assertion of reset. See the Strapping Options section for details.
28	RXC/ B-CAST_OFF	lpd/O	MII Mode: MII Receive Clock Output. Config. Mode: The pull-up/pull-down value is latched as B-CAST_OFF at the de-assertion of reset. See the Strapping Options section for details.
29	RXER/ ISO	lpd/O	MII Mode: MII Receive Error output Config. Mode: The pull-up/pull-down value is latched as ISOLATE at the de-assertion of reset. See the Strapping Options section for details.
30	GND	Gnd	Ground.
31	VDD_1.2	P	1.2V Core V _{DD} (power supplied by KSZ8081MLX). Decouple with 0.1µF capacitor to ground, and join with Pin 4 by power trace or plane.
32	INTRP/ NAND_Tree#	lpu/Opu	Interrupt Output: Programmable interrupt output. This pin has a weak pull-up, is open drain, and requires an external 1.0kΩ pull-up resistor. Config. Mode: The pull-up/pull-down value is latched as NAND Tree# at the de-assertion of reset. See the Strapping Options section for details.
33	TXC	lpd/O	MII Mode: MII Transmit Clock Output. At the de-assertion of reset, this pin needs to latch in a pull-down value for normal operation. If MAC side pulls this pin high, see Register 16h, Bit [15] for solution.
34	TXEN	I	MII Mode: MII Transmit Enable input.

Pin Description (Continued)

Pin Number	Pin Name	Type ⁽²⁾	Pin Function																											
35	TXD0	I	MII Mode: MII Transmit Data Input[0] ⁽⁴⁾																											
36	TXD1	I	MII Mode: MII Transmit Data Input[1] ⁽⁴⁾																											
37	GND	GND	Ground.																											
38	TXD2	I	MII Mode: MII Transmit Data Input[2] ⁽⁴⁾																											
39	TXD3	I	MII Mode: MII Transmit Data Input[3] ⁽⁴⁾																											
40	COL/ CONFIG0	lpd/O	MII Mode: MII Collision Detect output Config. Mode: The pull-up/pull-down value is latched as CONFIG0 at the de-assertion of reset. See the Strapping Options section for details.																											
41	CRS/ CONFIG1	lpd/O	MII Mode: MII Carrier Sense Output Config. Mode: The pull-up/pull-down value is latched as CONFIG1 at the de-assertion of reset. See the Strapping Options section for details.																											
42	LED0/ NWAYEN	lpu/O	<p>LED Output: Programmable LED0 Output Config. Mode: Latched as auto-negotiation enable (Register 0h, Bit [12]) at the de-assertion of reset. See the Strapping Options section for details. The LED0 pin is programmable using Register 1Fh Bits [5:4], and is defined as follows:</p> <table border="1"> <thead> <tr> <th colspan="3">LED Mode = [00]</th> </tr> <tr> <th>Link/Activity</th> <th>Pin State</th> <th>LED Definition</th> </tr> </thead> <tbody> <tr> <td>No link</td> <td>High</td> <td>OFF</td> </tr> <tr> <td>Link</td> <td>Low</td> <td>ON</td> </tr> <tr> <td>Activity</td> <td>Toggle</td> <td>Blinking</td> </tr> </tbody> </table> <table border="1"> <thead> <tr> <th colspan="3">LED Mode = [01]</th> </tr> <tr> <th>Link</th> <th>Pin State</th> <th>LED Definition</th> </tr> </thead> <tbody> <tr> <td>No link</td> <td>High</td> <td>OFF</td> </tr> <tr> <td>Link</td> <td>Low</td> <td>ON</td> </tr> </tbody> </table> <p>LED Mode = [10], [11] Reserved</p>	LED Mode = [00]			Link/Activity	Pin State	LED Definition	No link	High	OFF	Link	Low	ON	Activity	Toggle	Blinking	LED Mode = [01]			Link	Pin State	LED Definition	No link	High	OFF	Link	Low	ON
LED Mode = [00]																														
Link/Activity	Pin State	LED Definition																												
No link	High	OFF																												
Link	Low	ON																												
Activity	Toggle	Blinking																												
LED Mode = [01]																														
Link	Pin State	LED Definition																												
No link	High	OFF																												
Link	Low	ON																												

Note:

4. MII TX Mode: The TXD[3:0] bits are synchronous with TXC. When TXEN is asserted, TXD[3:0] presents valid data from the MAC.

Pin Description (Continued)

Pin Number	Pin Name	Type ⁽¹⁾	Pin Function																								
43	LED1/ SPEED	lpu/O	<p>LED Output: Programmable LED1 output</p> <p>Config. Mode: Latched as Speed (Register 0h, Bit [13]) at the de-assertion of reset. See the Strapping Options section for details.</p> <p>The LED1 pin is programmable using Register 1Fh Bits [5:4], and is defined as follows:</p> <table border="1"> <thead> <tr> <th colspan="3">LED Mode = [00]</th> </tr> <tr> <th>Speed</th> <th>Pin State</th> <th>LED Definition</th> </tr> </thead> <tbody> <tr> <td>10Base-T</td> <td>High</td> <td>OFF</td> </tr> <tr> <td>100Base-TX</td> <td>Low</td> <td>ON</td> </tr> </tbody> </table> <table border="1"> <thead> <tr> <th colspan="3">LED Mode = [01]</th> </tr> <tr> <th>Activity</th> <th>Pin State</th> <th>LED Definition</th> </tr> </thead> <tbody> <tr> <td>No activity</td> <td>High</td> <td>OFF</td> </tr> <tr> <td>Activity</td> <td>Toggle</td> <td>Blinking</td> </tr> </tbody> </table> <p>LED Mode = [10], [11] Reserved</p>	LED Mode = [00]			Speed	Pin State	LED Definition	10Base-T	High	OFF	100Base-TX	Low	ON	LED Mode = [01]			Activity	Pin State	LED Definition	No activity	High	OFF	Activity	Toggle	Blinking
LED Mode = [00]																											
Speed	Pin State	LED Definition																									
10Base-T	High	OFF																									
100Base-TX	Low	ON																									
LED Mode = [01]																											
Activity	Pin State	LED Definition																									
No activity	High	OFF																									
Activity	Toggle	Blinking																									
44	NC	-	No Connect. This pin is not bonded and can be left floating.																								
45	NC	-	No Connect. This pin is not bonded and can be left floating.																								
46	NC	-	No Connect. This pin is not bonded and can be left floating.																								
47	RST#	lpu	Chip Reset (active low)																								
48	NC	-	No Connect. This pin is not bonded and can be left floating.																								

Strapping Options

The strap-in pins are latched at the de-assertion of reset. In some systems, the MAC MII receive input pins may drive high/low during power-up or reset, and consequently cause the PHY strap-in pins on the MII signals to be latched to unintended high/low states. In this case, external pull-ups (4.7k Ω) or pull-downs (1.0k Ω) should be added on these PHY strap-in pins to ensure the intended values are strapped-in correctly.

Pin Number	Pin Name	Type ⁽⁵⁾	Pin Function								
22 21 20	PHYAD2 PHYAD1 PHYAD0	lpd/O lpd/O lpu/O	The PHY address is latched at de-assertion of reset and is configurable to any value from 0 to 7. The default PHY address is 00001. PHY address 00000 is enabled only if the B-CAST_OFF strapping pin is pulled high. PHY address Bits [4:3] are set to 00 by default.								
27 41 40	CONFIG2 CONFIG1 CONFIG0	lpd/O lpd/O lpd/O	<p>The CONFIG[2:0] strap-in pins are latched at the de-assertion of reset.</p> <table border="1"> <thead> <tr> <th>CONFIG[2:0]</th> <th>Mode</th> </tr> </thead> <tbody> <tr> <td>000</td> <td>MII (default)</td> </tr> <tr> <td>110</td> <td>MII back-to-back</td> </tr> <tr> <td>001 – 101, 111</td> <td>Reserved – not used</td> </tr> </tbody> </table>	CONFIG[2:0]	Mode	000	MII (default)	110	MII back-to-back	001 – 101, 111	Reserved – not used
CONFIG[2:0]	Mode										
000	MII (default)										
110	MII back-to-back										
001 – 101, 111	Reserved – not used										

Note:

5. lpu/O = Input with internal pull-up (see [Electrical Characteristics](#)⁽⁹⁾ for value) during power-up/reset; output pin otherwise.
 lpd/O = Input with internal pull-down (see [Electrical Characteristics](#)⁽⁹⁾ for value) during power-up/reset; output pin otherwise.
 lpu/Opu = Input with internal pull-up (see [Electrical Characteristics](#)⁽⁹⁾ for value) and output with internal pull-up (see [Electrical Characteristics](#)⁽⁹⁾ for value).

Strapping Options (Continued)

Pin Number	Pin Name	Type ⁽⁵⁾	Pin Function
29	ISO	Ipd/O	Isolate Mode: Pull-up = Enable Pull-down (default) = Disable At the de-assertion of reset, this pin value is latched into Register 0h, Bit [10].
43	SPEED	Ipu/O	Speed Mode: Pull-up (default) = 100Mbps Pull-down = 10Mbps At the de-assertion of reset, this pin value is latched into Register 0h, Bit [13] as the speed select, and also is latched into Register 4h (auto-negotiation advertisement) as the speed capability support.
23	DUPLEX	Ipu/O	Duplex Mode: Pull-up (default) = Half-duplex Pull-down = Full-duplex At the de-assertion of reset, this pin value is latched into Register 0h, Bit [8].
42	NWAYEN	Ipu/O	Nway Auto-Negotiation Enable: Pull-up (default) = Enable auto-negotiation Pull-down = Disable auto-negotiation At the de-assertion of reset, this pin value is latched into Register 0h, Bit [12].
28	B-CAST_OFF	Ipd/O	Broadcast Off – for PHY Address 0: Pull-up = PHY Address 0 is set as an unique PHY address Pull-down (default) = PHY Address 0 is set as a broadcast PHY address At the de-assertion of reset, this pin value is latched by the chip.
32	NAND_Tree#	Ipu/Opu	NAND Tree Mode: Pull-up (default) = Disable Pull-down = Enable At the de-assertion of reset, this pin value is latched by the chip.

Functional Description: 10Base-T/100Base-TX Transceiver

The KSZ8081MLX is an integrated single 3.3V supply Fast Ethernet transceiver. It is fully compliant with the IEEE 802.3 Specification, and reduces board cost and simplifies board layout by using on-chip termination resistors for the two differential pairs and by integrating the regulator to supply the 1.2V core.

On the copper media side, the KSZ8081MLX supports 10Base-T and 100Base-TX for transmission and reception of data over a standard CAT-5 unshielded twisted pair (UTP) cable, and HP Auto MDI/MDI-X for reliable detection of and correction for straight-through and crossover cables.

On the MAC processor side, the KSZ8081MLX offers the Media Independent Interface (MII) for direct connection with MII compliant Ethernet MAC processors and switches.

The MII management bus option gives the MAC processor complete access to the KSZ8081MLX control and status registers. Additionally, an interrupt pin eliminates the need for the processor to poll for PHY status change.

100Base-TX Transmit

The 100Base-TX transmit function performs parallel-to-serial conversion, 4B/5B encoding, scrambling, NRZ-to-NRZI conversion, and MLT3 encoding and transmission.

The circuitry starts with a parallel-to-serial conversion, which converts the MII data from the MAC into a 125MHz serial bit stream. The data and control stream is then converted into 4B/5B coding and followed by a scrambler. The serialized data is further converted from NRZ-to-NRZI format, and then transmitted in MLT3 current output. The output current is set by an external 6.49k Ω 1% resistor for the 1:1 transformer ratio.

The output signal has a typical rise/fall time of 4ns and complies with the ANSI TP-PMD standard regarding amplitude balance, overshoot, and timing jitter. The wave-shaped 10Base-T output is also incorporated into the 100Base-TX transmitter.

100Base-TX Receive

The 100Base-TX receiver function performs adaptive equalization, DC restoration, MLT3-to-NRZI conversion, data and clock recovery, NRZI-to-NRZ conversion, de-scrambling, 4B/5B decoding, and serial-to-parallel conversion.

The receiving side starts with the equalization filter to compensate for inter-symbol interference (ISI) over the twisted pair cable. Because the amplitude loss and phase distortion is a function of the cable length, the equalizer must adjust its characteristics to optimize performance. In this design, the variable equalizer makes an initial estimation based on comparisons of incoming signal strength against some known cable characteristics, then tunes itself for optimization. This is an ongoing process and self-adjusts against environmental changes such as temperature variations.

Next, the equalized signal goes through a DC-restoration and data-conversion block. The DC-restoration circuit compensates for the effect of baseline wander and improves the dynamic range. The differential data-conversion circuit converts MLT3 format back to NRZI. The slicing threshold is also adaptive.

The clock-recovery circuit extracts the 125MHz clock from the edges of the NRZI signal. This recovered clock is then used to convert the NRZI signal into NRZ format. This signal is sent through the de-scrambler, then the 4B/5B decoder. Finally, the NRZ serial data is converted to MII format and provided as the input data to the MAC.

Scrambler/De-Scrambler (100Base-TX Only)

The scrambler spreads the power spectrum of the transmitted signal to reduce electromagnetic interference (EMI) and baseline wander. The de-scrambler recovers the scrambled signal.

10Base-T Transmit

The 10Base-T drivers are incorporated with the 100Base-TX drivers to allow for transmission using the same magnetic. The drivers perform internal wave-shaping and pre-emphasis, and output 10Base-T signals with typical amplitude of 2.5V peak. The 10Base-T signals have harmonic contents that are at least 27dB below the fundamental frequency when driven by an all-ones Manchester-encoded signal.

10Base-T Receive

On the receive side, input buffer and level detecting squelch circuits are used. A differential input receiver circuit and a phase-locked loop (PLL) performs the decoding function. The Manchester-encoded data stream is separated into clock signal and NRZ data. A squelch circuit rejects signals with levels less than 400mV, or with short pulse widths, to prevent noise at the RXP and RXM inputs from falsely triggering the decoder. When the input exceeds the squelch limit, the PLL locks onto the incoming signal and the KSZ8081MLX decodes a data frame. The receive clock is kept active during idle periods between data receptions.

SQE and Jabber Function (10Base-T Only)

In 10Base-T operation, a short pulse is put out on the COL pin after each frame is transmitted. This SQE test is needed to test the 10Base-T transmit/receive path. If transmit enable (TXEN) is high for more than 20ms (jabbering), the 10Base-T transmitter is disabled and COL is asserted high. If TXEN is then driven low for more than 250ms, the 10Base-T transmitter is re-enabled and COL is de-asserted (returns to low).

PLL Clock Synthesizer

The KSZ8081MLX generates all internal clocks and all external clocks for system timing from an external 25MHz crystal, oscillator, or reference clock.

Auto-Negotiation

The KSZ8081MLX conforms to the auto-negotiation protocol, defined in Clause 28 of the IEEE 802.3 Specification.

Auto-negotiation allows unshielded twisted pair (UTP) link partners to select the highest common mode of operation.

During auto-negotiation, link partners advertise capabilities across the UTP link to each other and then compare their own capabilities with those they received from their link partners. The highest speed and duplex setting that is common to the two link partners is selected as the mode of operation.

The following list shows the speed and duplex operation mode from highest to lowest priority.

- Priority 1: 100Base-TX, full-duplex
- Priority 2: 100Base-TX, half-duplex
- Priority 3: 10Base-T, full-duplex
- Priority 4: 10Base-T, half-duplex

If auto-negotiation is not supported or the KSZ8081MLX link partner is forced to bypass auto-negotiation, then the KSZ8081MLX sets its operating mode by observing the signal at its receiver. This is known as parallel detection, and allows the KSZ8081MLX to establish a link by listening for a fixed signal protocol in the absence of the auto-negotiation advertisement protocol.

Auto-negotiation is enabled by either hardware pin strapping (NWAYEN, Pin 42) or software (Register 0h, Bit [12]).

By default, auto-negotiation is enabled after power-up or hardware reset. After that, auto-negotiation can be enabled or disabled by Register 0h, Bit [12]. If auto-negotiation is disabled, the speed is set by Register 0h, Bit [13], and the duplex is set by Register 0h, Bit [8].

The auto-negotiation link-up process is shown in [Figure 1](#).

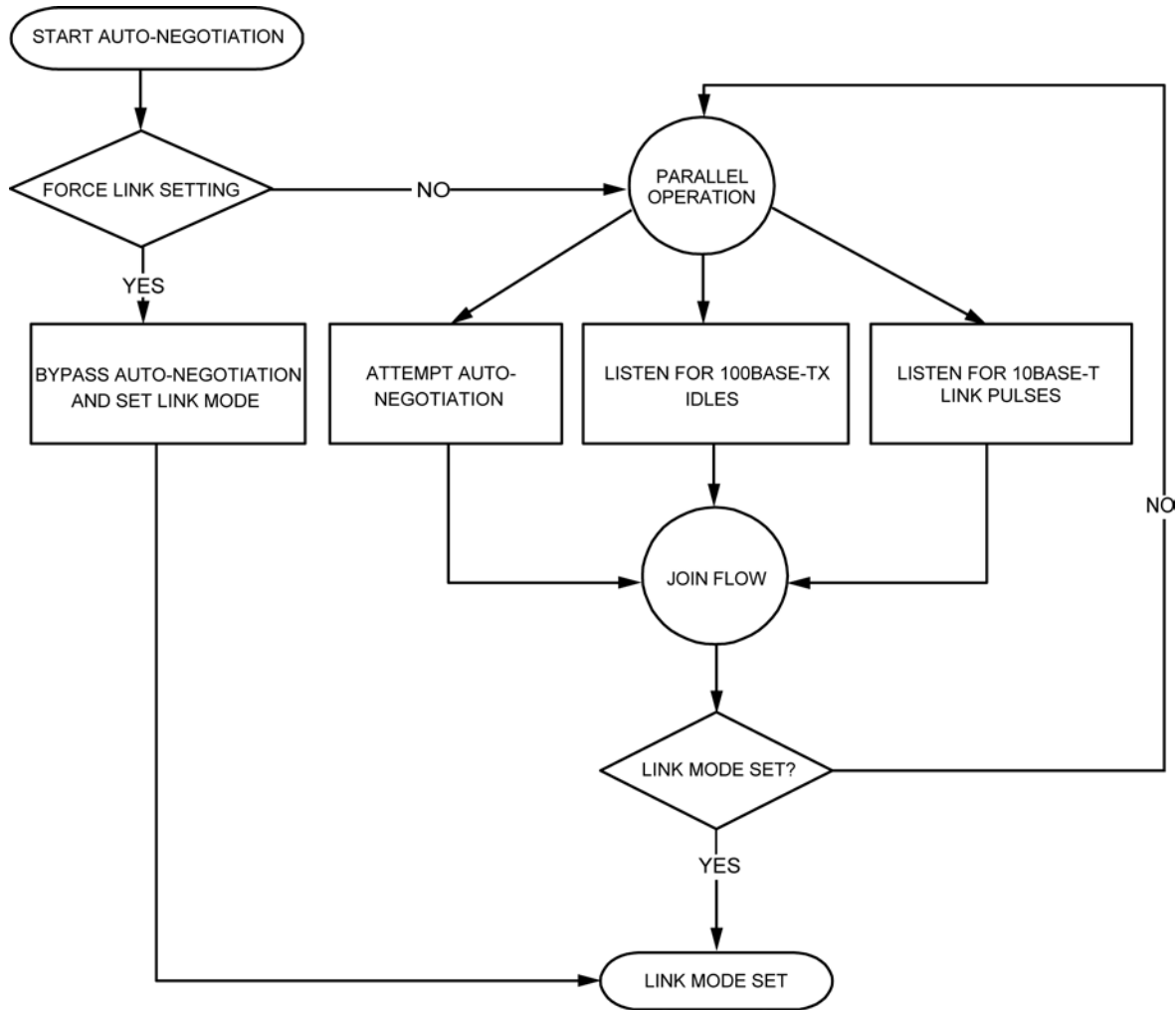

Figure 1. Auto-Negotiation Flow Chart

MII Interface

The Media Independent Interface (MII) is compliant with the IEEE 802.3 Specification. It provides a common interface between MII PHYs and MACs, and has the following key characteristics:

- Pin count is 15 pins (6 pins for data transmission, 7 pins for data reception, and 2 pins for carrier and collision indication).
- 10Mbps and 100Mbps data rates are supported at both half- and full-duplex.
- Data transmission and reception are independent and belong to separate signal groups.
- Transmit data and receive data are each 4 bits wide, a nibble.

By default, the KSZ8081MLX is configured to MII mode after it is powered up or hardware reset with the following:

- A 25MHz crystal connected to XI, XO (Pins 15, 14), or an external 25MHz clock source (oscillator) connected to XI.
- The CONFIG[2:0] strapping pins (Pins 27, 41, 40) set to 000 (default setting).

MII Signal Definition

Table 1 describes the MII signals. Refer to Clause 22 of the IEEE 802.3 Specification for detailed information.

Table 1. MII Signal Definition

MII Signal Name	Direction (with respect to PHY, KSZ8081MLX signal)	Direction (with respect to MAC)	Description
TXC	Output	Input	Transmit Clock (2.5MHz for 10Mbps; 25MHz for 100Mbps)
TXEN	Input	Output	Transmit Enable
TXD[3:0]	Input	Output	Transmit Data[3:0]
RXC	Output	Input	Receive Clock (2.5MHz for 10Mbps; 25MHz for 100Mbps)
RXDV	Output	Input	Receive Data Valid
RXD[3:0]	Output	Input	Receive Data[3:0]
RXER	Output	Input, or (not required)	Receive Error
CRS	Output	Input	Carrier Sense
COL	Output	Input	Collision Detection

Transmit Clock (TXC)

TXC is sourced by the PHY. It is a continuous clock that provides the timing reference for TXEN and TXD[3:0].

TXC is 2.5MHz for 10Mbps operation and 25MHz for 100Mbps operation.

Transmit Enable (TXEN)

TXEN indicates that the MAC is presenting nibbles on TXD[3:0] for transmission. It is asserted synchronously with the first nibble of the preamble and remains asserted while all nibbles to be transmitted are presented on the MII. It is negated before the first TXC following the final nibble of a frame.

TXEN transitions synchronously with respect to TXC.

Transmit Data[3:0] (TXD[3:0])

When TXEN is asserted, TXD[3:0] are the data nibbles accepted by the PHY for transmission. TXD[3:0] is 00 to indicate idle when TXEN is de-asserted.

TXD[3:0] transitions synchronously with respect to TXC.

Receive Clock (RXC)

RXC provides the timing reference for RXDV, RXD[3:0], and RXER.

In 10Mbps mode, RXC is recovered from the line while the carrier is active. RXC is derived from the PHY's reference clock when the line is idle or the link is down.

In 100Mbps mode, RXC is continuously recovered from the line. If the link is down, RXC is derived from the PHY's reference clock.

RXC is 2.5MHz for 10Mbps operation and 25MHz for 100Mbps operation.

Receive Data Valid (RXDV)

RXDV is driven by the PHY to indicate that the PHY is presenting recovered and decoded nibbles on RXD[3:0].

In 10Mbps mode, RXDV is asserted with the first nibble of the start-of-frame delimiter (SFD), 5D, and remains asserted until the end of the frame.

In 100Mbps mode, RXDV is asserted from the first nibble of the preamble to the last nibble of the frame.

RXDV transitions synchronously with respect to RXC.

Receive Data[3:0] (RXD[3:0])

RXD[3:0] transitions synchronously with respect to RXC. For each clock period in which RXDV is asserted, RXD[3:0] transfers a nibble of recovered data from the PHY.

Receive Error (RXER)

RXER is asserted for one or more RXC periods to indicate that a symbol error (for example, a coding error that a PHY can detect that may otherwise be undetectable by the MAC sub-layer) was detected somewhere in the frame being transferred from the PHY.

RXER transitions synchronously with respect to RXC.

Carrier Sense (CRS)

CRS is asserted and de-asserted as follows:

In 10Mbps mode, CRS assertion is based on the reception of valid preambles. CRS de-assertion is based on the reception of an end-of-frame (EOF) marker.

In 100Mbps mode, CRS is asserted when a start-of-stream delimiter or /J/K symbol pair is detected. CRS is de-asserted when an end-of-stream delimiter or /T/R symbol pair is detected. Additionally, the PMA layer de-asserts CRS if IDLE symbols are received without /T/R.

Collision (COL)

COL is asserted in half-duplex mode whenever the transmitter and receiver are simultaneously active on the line. This informs the MAC that a collision has occurred during its transmission to the PHY.

COL transitions asynchronously with respect to TXC and RXC.

MII Signal Diagram

The KSZ8081MLX MII pin connections to the MAC are shown in [Figure 2](#).

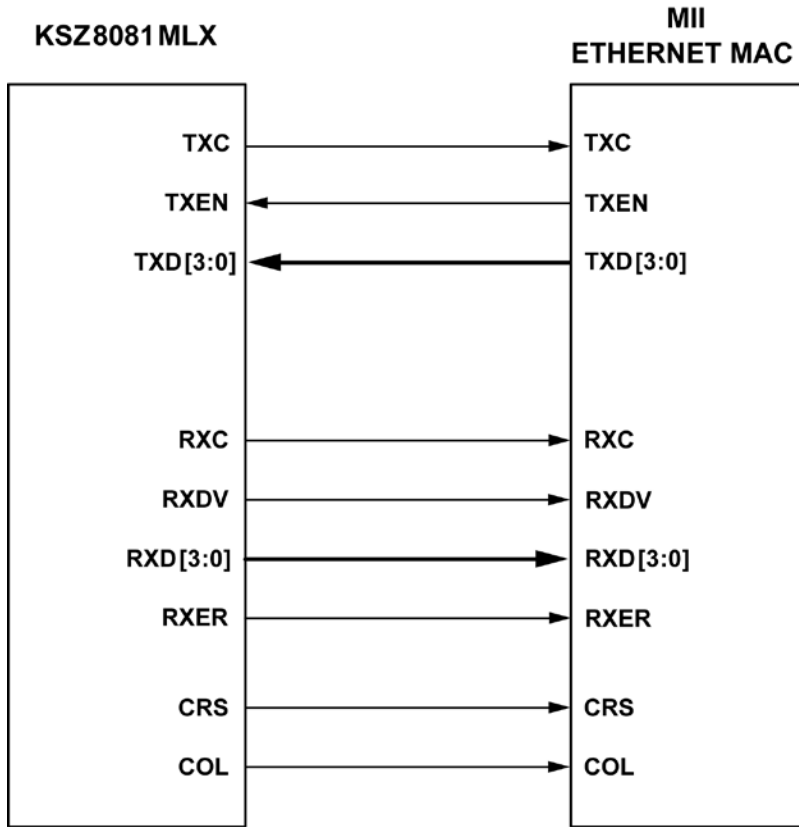

Figure 2. KSZ8081MLX MII Interface

Back-to-Back Mode – 100Mbps Copper Repeater

Two KSZ8081MLX devices can be connected back-to-back to form a 100Base-TX to 100Base-TX copper repeater.

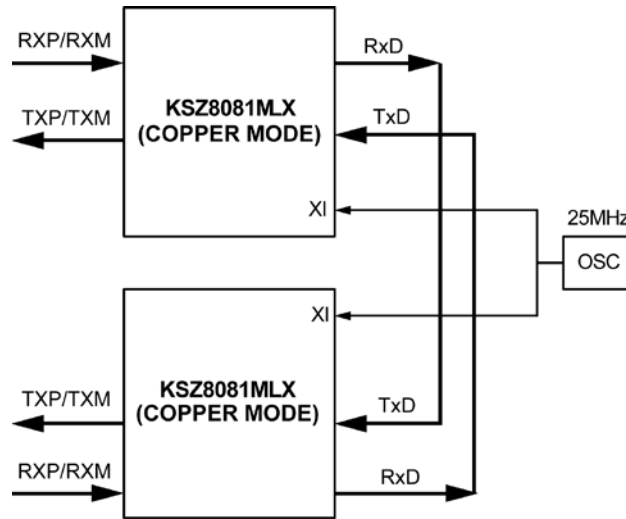

Figure 3. KSZ8081MLX to KSZ8081MLX Back-to-Back Copper Repeater

MII Back-to-Back Mode

In MII back-to-back mode, a KSZ8081MLX interfaces with another KSZ8081MLX to provide a complete 100Mbps copper repeater solution.

The KSZ8081MLX devices are configured to MII back-to-back mode after power-up or reset with the following:

Strapping pin CONFIG[2:0] (Pins 27, 41, 40) set to 110

A common 25MHz reference clock connected to XI (Pin 15) of both KSZ8081MLX devices

MII signals connected as shown in [Table 2](#).

Table 2. MII Signal Connection for MII Back-to-Back Mode (100Base-TX Copper Repeater)

KSZ8081MLX (100Base-TX copper) [Device 1]			KSZ8081MLX (100Base-TX copper) [Device 2]		
Pin Name	Pin Number	Pin Type	Pin Name	Pin Number	Pin Type
RXDV	27	Output	TXEN	34	Input
RXD3	20	Output	TXD3	39	Input
RXD2	21	Output	TXD2	38	Input
RXD1	22	Output	TXD1	36	Input
RXD0	23	Output	TXD0	35	Input
TXEN	34	Input	RXDV	27	Output
TXD3	39	Input	RXD3	20	Output
TXD2	38	Input	RXD2	21	Output
TXD1	36	Input	RXD1	22	Output
TXD0	35	Input	RXD0	23	Output

MII Management (MIIM) Interface

The KSZ8081MLX supports the IEEE 802.3 MII management interface, also known as the Management Data Input/Output (MDIO) interface. This interface allows an upper-layer device, such as a MAC processor, to monitor and control the state of the KSZ8081MLX. An external device with MIIM capability is used to read the PHY status and/or configure the PHY settings. More details about the MIIM interface can be found in Clause 22.2.4 of the IEEE 802.3 Specification.

The MIIM interface consists of the following:

- A physical connection that incorporates the clock line (MDC) and the data line (MDIO).
- A specific protocol that operates across the physical connection mentioned earlier, which allows the external controller to communicate with one or more PHY devices.
- A set of 16-bit MDIO registers. Supported registers [0:8] are standard registers, and their functions are defined in the IEEE 802.3 Specification. The additional registers are provided for expanded functionality. See the [Register Map](#) section for details.

As the default, the KSZ8081MLX supports unique PHY addresses 1 to 7, and broadcast PHY address 0. The latter is defined in the IEEE 802.3 Specification, and can be used to read/write to a single KSZ8081MLX device, or write to multiple KSZ8081MLX devices simultaneously.

PHY address 0 can optionally be disabled as the broadcast address by either hardware pin strapping (B-CAST_OFF, Pin 28) or software (Register 16h, Bit [9]), and assigned as a unique PHY address.

The PHYAD[2:0] strapping pins are used to assign a unique PHY address between 0 and 7 to each KSZ8081MLX device.

[Table 3](#) shows the MII management frame format for the KSZ8081MLX.

Table 3. MII Management Frame Format for the KSZ8081MLX

	Preamble	Start of Frame	Read/Write OP Code	PHY Address Bits [4:0]	REG Address Bits [4:0]	TA	Data Bits [15:0]	Idle
Read	32 1's	01	10	00AAA	RRRRR	Z0	DDDDDDDD_DDDDDDDD	Z
Write	32 1's	01	01	00AAA	RRRRR	10	DDDDDDDD_DDDDDDDD	Z

Interrupt (INTRP)

INTRP (Pin 32) is an optional interrupt signal that is used to inform the external controller that there has been a status update to the KSZ8081MLX PHY Register. Bits [15:8] of Register 1Bh are the interrupt control bits to enable and disable the conditions for asserting the INTRP signal. Bits [7:0] of Register 1Bh are the interrupt status bits to indicate which interrupt conditions have occurred. The interrupt status bits are cleared after reading Register 1Bh.

Bit [9] of Register 1Fh sets the interrupt level to active high or active low. The default is active low.

The MII management bus option gives the MAC processor complete access to the KSZ8081MLX control and status registers. Additionally, an interrupt pin eliminates the need for the processor to poll the PHY for status change.

HP Auto MDI/MDI-X

HP Auto MDI/MDI-X configuration eliminates the need to decide whether to use a straight cable or a crossover cable between the KSZ8081MLX and its link partner. This feature allows the KSZ8081MLX to use either type of cable to connect with a link partner that is in either MDI or MDI-X mode. The auto-sense function detects transmit and receive pairs from the link partner and assigns transmit and receive pairs of the KSZ8081MLX accordingly.

HP Auto MDI/MDI-X is enabled by default. It is disabled by writing a '1' to Register 1Fh, Bit [13]. MDI and MDI-X mode is selected by Register 1Fh, Bit [14] if HP Auto MDI/MDI-X is disabled.

An isolation transformer with symmetrical transmit and receive data paths is recommended to support Auto MDI/MDI-X.

Table 4 shows how the IEEE 802.3 Standard defines MDI and MDI-X.

Table 4. MDI/MDI-X Pin Definition

MDI		MDI-X	
RJ-45 Pin	Signal	RJ-45 Pin	Signal
1	TX+	1	RX+
2	TX-	2	RX-
3	RX+	3	TX+
6	RX-	6	TX-

Straight Cable

A straight cable connects an MDI device to an MDI-X device, or an MDI-X device to an MDI device. Figure 4 shows a typical straight cable connection between a NIC card (MDI device) and a switch or hub (MDI-X device).

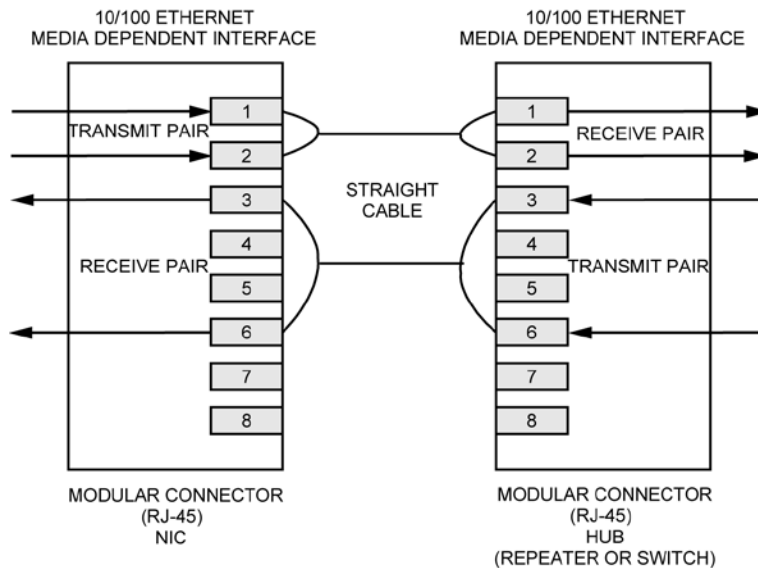

Figure 4. Typical Straight Cable Connection

Crossover Cable

A crossover cable connects an MDI device to another MDI device, or an MDI-X device to another MDI-X device. Figure 5 shows a typical crossover cable connection between two switches or hubs (two MDI-X devices).

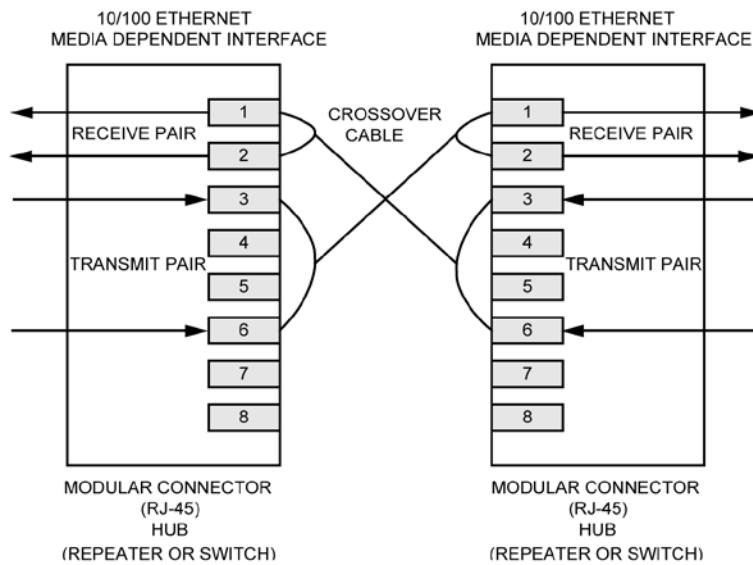

Figure 5. Typical Crossover Cable Connection

Loopback Mode

The KSZ8081MLX supports the following loopback operations to verify analog and/or digital data paths.

- Local (digital) loopback
- Remote (analog) loopback

Local (Digital) Loopback

This loopback mode checks the MII transmit and receive data paths between the KSZ8081MLX and the external MAC, and is supported for both speeds (10/100Mbps) at full-duplex.

The loopback data path is shown in [Figure 6](#).

1. The MII MAC transmits frames to the KSZ8081MLX.
2. Frames are wrapped around inside the KSZ8081MLX.
3. The KSZ8081MLX transmits frames back to the MII MAC.

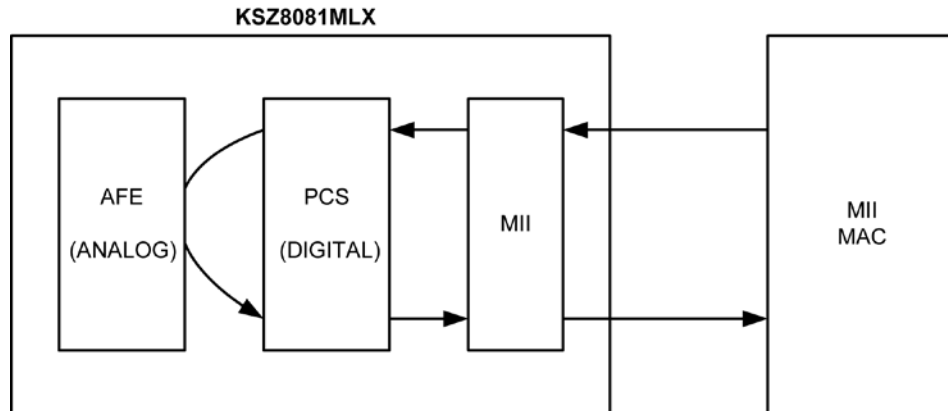

Figure 6. Local (Digital) Loopback

The following programming action and register settings are used for local loopback mode.

For 10/100Mbps loopback,

Set Register 0h,

Bit [14] = 1 // Enable local loopback mode
 Bit [13] = 0/1 // Select 10Mbps/100Mbps speed
 Bit [12] = 0 // Disable auto-negotiation
 Bit [8] = 1 // Select full-duplex mode

Remote (Analog) Loopback

This loopback mode checks the line (differential pairs, transformer, RJ-45 connector, Ethernet cable) transmit and receive data paths between the KSZ8081MLX and its link partner. It is supported for 100Base-TX full-duplex mode only.

The loopback data path is shown in [Figure 7](#).

1. The Fast Ethernet (100Base-TX) PHY link partner transmits frames to the KSZ8081MLX.
2. Frames are wrapped around inside the KSZ8081MLX.
3. The KSZ8081MLX transmits frames back to the Fast Ethernet (100Base-TX) PHY link partner.

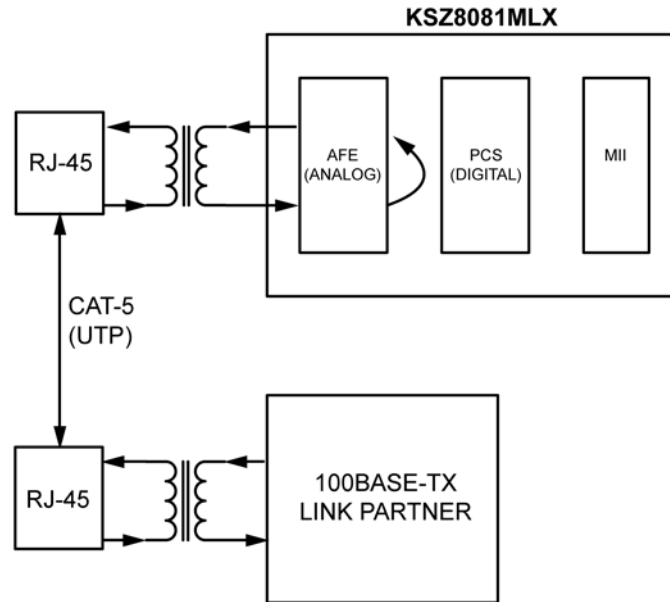

Figure 7. Remote (Analog) Loopback

The following programming steps and register settings are used for remote loopback mode:

1. Set Register 0h,
 - Bits [13] = 1 // Select 100Mbps speed
 - Bit [12] = 0 // Disable auto-negotiation
 - Bit [8] = 1 // Select full-duplex mode
 - Or just auto-negotiate and link up at 100Base-TX full-duplex mode with the link partner
2. Set Register 1Fh,
 - Bit [2] = 1 // Enable remote loopback mode

LinkMD[®] Cable Diagnostic

The LinkMD function uses time-domain reflectometry (TDR) to analyze the cabling plant for common cabling problems. These include open circuits, short circuits, and impedance mismatches.

LinkMD works by sending a pulse of known amplitude and duration down the MDI or MDI-X pair, then analyzing the shape of the reflected signal to determine the type of fault. The time duration for the reflected signal to return provides the approximate distance to the cabling fault. The LinkMD function processes this TDR information and presents it as a numerical value that can be translated to a cable distance.

LinkMD is initiated by accessing Register 1Dh, the LinkMD Control/Status register, in conjunction with Register 1Fh, the PHY Control 2 register. The latter register is used to disable Auto MDI/MDI-X and to select either MDI or MDI-X as the cable differential pair for testing.

NAND Tree Support

The KSZ8081MLX provides parametric NAND tree support for fault detection between chip I/Os and board. The NAND tree is a chain of nested NAND gates in which each KSZ8081MLX digital I/O (NAND tree input) pin is an input to one NAND gate along the chain. At the end of the chain, the CRS/CONFIG1 pin provides the output for the nested NAND gates.

The NAND tree test process includes:

- Enabling NAND tree mode
- Pulling all NAND tree input pins high
- Driving each NAND tree input pin low, sequentially, according to the NAND tree pin order
- Checking the NAND tree output to make sure there is a toggle high-to-low or low-to-high for each NAND tree input driven low

[Table 5](#) lists the NAND tree pin order.

Table 5. NAND Tree Test Pin Order for KSZ8081MLX

Pin Number	Pin Name	NAND Tree Description
18	MDIO	Input
19	MDC	Input
20	RXD3	Input
21	RXD2	Input
22	RXD1	Input
23	RXD0	Input
27	RXDV	Input
28	RXC	Input
29	RXER	Input
32	INTRP	Input
33	TXC	Input
34	TXEN	Input
35	TXD0	Input
36	TXD1	Input
38	TXD2	Input
39	TXD3	Input
42	LED0	Input
43	LED1	Input
40	COL	Input
41	CRS	Output

NAND Tree I/O Testing

Use the following procedure to check for faults on the KSZ8081MLX digital I/O pin connections to the board:

1. Enable NAND tree mode using either a hardware strap-in pin (NAND_Tree#, Pin 32) or software (Register 16h, Bit [5]).
2. Use board logic to drive all KSZ8081MLX NAND tree input pins high.
3. Use board logic to drive each NAND tree input pin, in KSZ8081MLX NAND tree pin order, as follows:
 - a. Toggle the first pin (MDIO) from high to low, and verify that the CRS/CONFIG1 pin switches from high to low to indicate that the first pin is connected properly.
 - b. Leave the first pin (MDIO) low.
 - c. Toggle the second pin (MDC) from high to low, and verify that the CRS/CONFIG1 pin switches from low to high to indicate that the second pin is connected properly.
 - d. Leave the first pin (MDIO) and the second pin (MDC) low.
 - e. Toggle the third pin (RXD3) from high to low, and verify that the CRS/CONFIG1 pin switches from high to low to indicate that the third pin is connected properly.
 - f. Continue with this sequence until all KSZ8081MLX NAND tree input pins have been toggled.

Each KSZ8081MLX NAND tree input pin must cause the CRS/CONFIG1 output pin to toggle high-to-low or low-to-high to indicate a good connection. If the CRS pin fails to toggle when the KSZ8081MLX input pin toggles from high to low, the input pin has a fault.

Power Management

The KSZ8081MLX incorporates a number of power-management modes and features that provide methods to consume less energy. These are discussed in the following sections.

Power-Saving Mode

Power-saving mode is used to reduce the transceiver power consumption when the cable is unplugged. It is enabled by writing a '1' to Register 1Fh, Bit [10], and is in effect when auto-negotiation mode is enabled and the cable is disconnected (no link).

In this mode, the KSZ8081MLX shuts down all transceiver blocks, except for the transmitter, energy detect, and PLL circuits.

By default, power-saving mode is disabled after power-up.

Energy-Detect Power-Down Mode

Energy-detect power-down (EDPD) mode is used to further reduce transceiver power consumption when the cable is unplugged. It is enabled by writing a '0' to Register 18h, Bit [11], and is in effect when auto-negotiation mode is enabled and the cable is disconnected (no link).

EDPD mode works with the PLL off (set by writing a '1' to Register 10h, Bit [4] to automatically turn the PLL off in EDPD mode) to turn off all KSZ8081MLX transceiver blocks, except for the transmitter and energy-detect circuits.

Power can be reduced further by extending the time interval between transmissions of link pulses to check for the presence of a link partner. The periodic transmission of link pulses is needed to ensure two link partners in the same low-power state, with Auto MDI/MDI-X disabled, can wake up when the cable is connected between them.

By default, energy-detect power-down mode is disabled after power-up.

Power-Down Mode

Power-down mode is used to power down the KSZ8081MLX device when it is not in use after power-up. It is enabled by writing a '1' to Register 0h, Bit [11].

In this mode, the KSZ8081MLX disables all internal functions except the MII management interface. The KSZ8081MLX exits (disables) power-down mode after Register 0h, Bit [11] is set back to '0'.

Slow-Oscillator Mode

Slow-oscillator mode is used to disconnect the input reference crystal/clock on XI (Pin 15) and select the on-chip slow oscillator when the KSZ8081MLX device is not in use after power-up. It is enabled by writing a '1' to Register 11h, Bit [5].

Slow-oscillator mode works in conjunction with power-down mode to put the KSZ8081MLX device in the lowest power state with all internal functions disabled except the MII management interface. To properly exit this mode and return to normal PHY operation, use the following programming sequence:

1. Disable slow-oscillator mode by writing a '0' to Register 11h, Bit [5].
2. Disable power-down mode by writing a '0' to Register 0h, Bit [11].
3. Initiate software reset by writing a '1' to Register 0h, Bit [15].

Reference Circuit for Power and Ground Connections

The KSZ8081MLX is a single 3.3V supply device with a built-in regulator to supply the 1.2V core. The power and ground connections are shown in Figure 8 and Table 6 for 3.3V VDDIO.

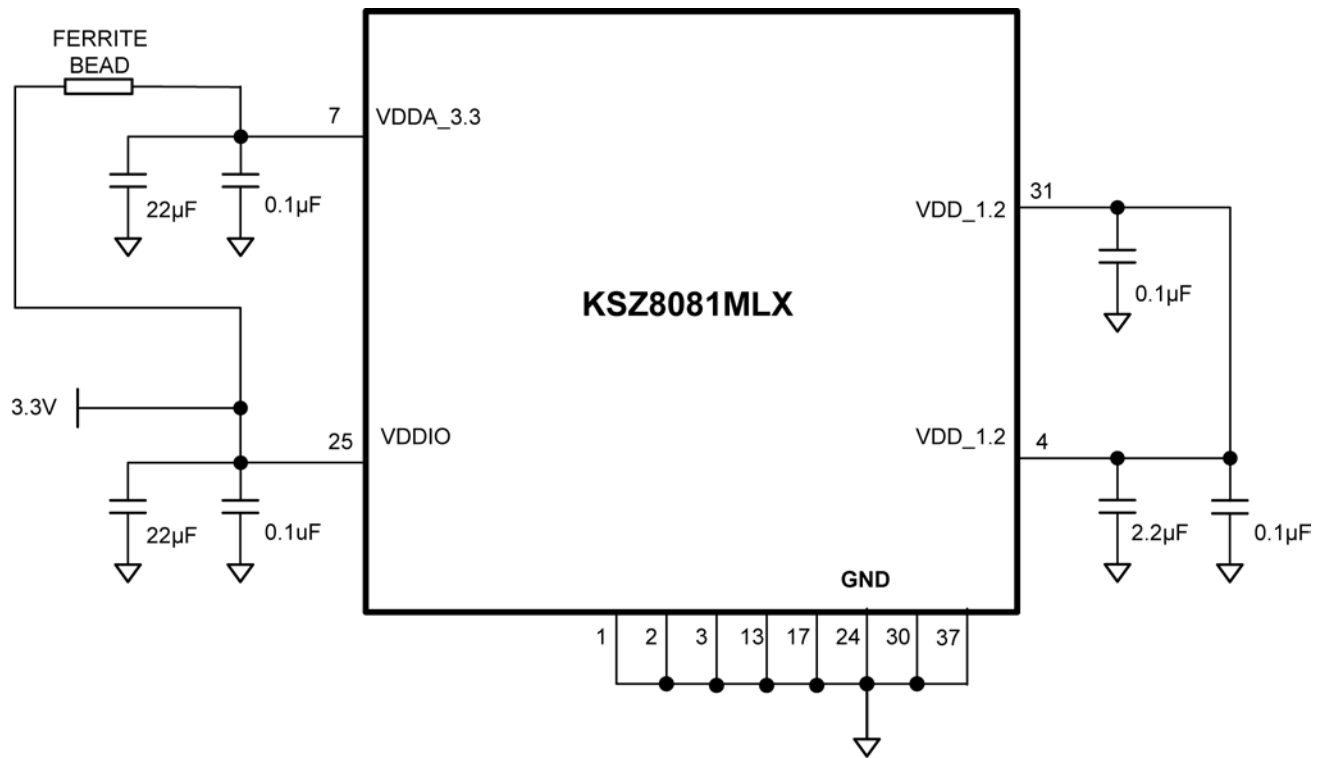

Figure 8. KSZ8081MLX Power and Ground Connections

Table 6. KSZ8081 Power Pin Description

Power Pin	Pin Number	Description
VDD_1.2	4	Connect with Pin 31 by power trace or plane. Decouple with 2.2µF and 0.1µF capacitors to ground.
VDDA_3.3	7	Connect to board's 3.3V supply through a ferrite bead. Decouple with 22µF and 0.1µF capacitors to ground.
VDDIO	25	Connect to board's 3.3V supply for 3.3V VDDIO. Decouple with 22µF and 0.1µF capacitors to ground.
VDD_1.2	31	Connect with Pin 4 by power trace or plane. Decouple with 0.1µF capacitor to ground.

Typical Current/Power Consumption

Table 7, Table 8, and Table 9 show typical values for current consumption by the transceiver (VDDA_3.3) and digital I/O (VDDIO) power pins and typical values for power consumption by the KSZ8081MLX device for the indicated nominal operating voltages. These current and power consumption values include the transmit driver current and on-chip regulator current for the 1.2V core.

Table 7. Typical Current/Power Consumption (VDDA_3.3 = 3.3V, VDDIO = 3.3V)

Transceiver (3.3V), Digital I/Os (3.3V)			
Condition	3.3V Transceiver (VDDA_3.3)	3.3V Digital I/Os (VDDIO)	Total Chip Power
	mA	mA	mW
100Base-TX Link-up (no traffic)	34	12	152
100Base-TX Full-duplex @ 100% utilization	34	13	155
10Base-T Link-up (no traffic)	14	11	82.5
10Base-T Full-duplex @ 100% utilization	30	11	135
Power-saving mode (Reg. 1Fh, Bit [10] = 1)	14	10	79.2
EDPD mode (Reg. 18h, Bit [11] = 0)	10	10	66.0
EDPD mode (Reg. 18h, Bit [11] = 0) and PLL off (Reg. 10h, Bit [4] = 1)	3.77	1.54	17.5
Software power-down mode (Reg. 0h, Bit [11] = 1)	2.59	1.51	13.5
Software power-down mode (Reg. 0h, Bit [11] = 1) and slow-oscillator mode (Reg. 11h, Bit [5] = 1)	1.36	0.45	5.97

Table 8. Typical Current/Power Consumption (VDDA_3.3 = 3.3V, VDDIO = 2.5V)

Transceiver (3.3V), Digital I/Os (2.5V)			
Condition	3.3V Transceiver (VDDA_3.3)	2.5V Digital I/Os (VDDIO)	Total Chip Power
	mA	mA	mW
100Base-TX Link-up (no traffic)	34	11	140
100Base-TX Full-duplex @ 100% utilization	34	12	142
10Base-T Link-up (no traffic)	15	10	74.5
10Base-T Full-duplex @ 100% utilization	27	10	114
Power-saving mode (Reg. 1Fh, Bit [10] = 1)	15	10	74.5
EDPD mode (Reg. 18h, Bit [11] = 0)	11	10	61.3
EDPD mode (Reg. 18h, Bit [11] = 0) and PLL off (Reg. 10h, Bit [4] = 1)	3.55	1.35	15.1
Software power-down mode (Reg. 0h, Bit [11] = 1)	2.29	1.34	10.9
Software power-down mode (Reg. 0h, Bit [11] = 1) and slow-oscillator mode (Reg. 11h, Bit [5] = 1)	1.15	0.29	4.52

Table 9. Typical Current/Power Consumption (VDDA_3.3 = 3.3V, VDDIO = 1.8V)

Transceiver (3.3V), Digital I/Os (1.8V)			
Condition	3.3V Transceiver (VDDA_3.3)	1.8V Digital I/Os (VDDIO)	Total Chip Power
	mA	mA	mW
100Base-TX Link-up (no traffic)	34	11	132
100Base-TX Full-duplex @ 100% utilization	34	12	134
10Base-T Link-up (no traffic)	15	9.0	65.7
10Base-T Full-duplex @ 100% utilization	27	9.0	105
Power-saving mode (Reg. 1Fh, Bit [10] = 1)	15	9.0	65.7
EDPD mode (Reg. 18h, Bit [11] = 0)	11	9.0	52.5
EDPD mode (Reg. 18h, Bit [11] = 0) and PLL off (Reg. 10h, Bit [4] = 1)	4.05	1.21	15.5
Software power-down mode (Reg. 0h, Bit [11] =1)	2.79	1.21	11.4
Software power-down mode (Reg. 0h, Bit [11] =1) and slow-oscillator mode (Reg. 11h, Bit [5] =1)	1.65	0.19	5.79

Register Map

Register Number (Hex)	Description
0h	Basic Control
1h	Basic Status
2h	PHY Identifier 1
3h	PHY Identifier 2
4h	Auto-Negotiation Advertisement
5h	Auto-Negotiation Link Partner Ability
6h	Auto-Negotiation Expansion
7h	Auto-Negotiation Next Page
8h	Link Partner Next Page Ability
9h – Fh	Reserved
10h	Digital Reserved Control
11h	AFE Control 1
12h – 14h	Reserved
15h	RXER Counter
16h	Operation Mode Strap Override
17h	Operation Mode Strap Status
18h	Expanded Control
19h – 1Ah	Reserved
1Bh	Interrupt Control/Status
1Ch	Reserved
1Dh	LinkMD Control/Status
1Eh	PHY Control 1
1Fh	PHY Control 2

Register Description

Address	Name	Description	Mode ⁽⁶⁾	Default
Register 0h – Basic Control				
0.15	Reset	1 = Software reset 0 = Normal operation This bit is self-cleared after a '1' is written to it.	RW/SC	0
0.14	Loopback	1 = Loopback mode 0 = Normal operation	RW	0
0.13	Speed Select	1 = 100Mbps 0 = 10Mbps This bit is ignored if auto-negotiation is enabled (Register 0.12 = 1).	RW	Set by the SPEED strapping pin. See the Strapping Options section for details.
0.12	Auto-Negotiation Enable	1 = Enable auto-negotiation process 0 = Disable auto-negotiation process If enabled, the auto-negotiation result overrides the settings in Register 0.13 and 0.8.	RW	Set by the NWAYEN strapping pin. See the Strapping Options section for details.
0.11	Power-Down	1 = Power-down mode 0 = Normal operation If software reset (Register 0.15) is used to exit power-down mode (Register 0.11 = 1), two software reset writes (Register 0.15 = 1) are required. The first write clears power-down mode; the second write resets the chip and re-latches the pin strapping pin values.	RW	0
0.10	Isolate	1 = Electrical isolation of PHY from MII 0 = Normal operation	RW	Set by the ISO strapping pin. See the Strapping Options section for details.
0.9	Restart Auto-Negotiation	1 = Restart auto-negotiation process 0 = Normal operation. This bit is self-cleared after a '1' is written to it.	RW/SC	0
0.8	Duplex Mode	1 = Full-duplex 0 = Half-duplex	RW	The inverse of the DUPLEX strapping pin value. See the Strapping Options section for details.
0.7	Collision Test	1 = Enable COL test 0 = Disable COL test	RW	0
0.6:0	Reserved	Reserved	RO	000_0000

Note:

6. RW = Read/Write.
RO = Read only.
SC = Self-cleared.
LH = Latch high.
LL = Latch low.

Register Description (Continued)

Address	Name	Description	Mode ⁽⁶⁾	Default
Register 1h – Basic Status				
1.15	100Base-T4	1 = T4 capable 0 = Not T4 capable	RO	0
1.14	100Base-TX Full-Duplex	1 = Capable of 100Mbps full-duplex 0 = Not capable of 100Mbps full-duplex	RO	1
1.13	100Base-TX Half-Duplex	1 = Capable of 100Mbps half-duplex 0 = Not capable of 100Mbps half-duplex	RO	1
1.12	10Base-T Full-Duplex	1 = Capable of 10Mbps full-duplex 0 = Not capable of 10Mbps full-duplex	RO	1
1.11	10Base-T Half-Duplex	1 = Capable of 10Mbps half-duplex 0 = Not capable of 10Mbps half-duplex	RO	1
1.10:7	Reserved	Reserved	RO	000_0
1.6	No Preamble	1 = Preamble suppression 0 = Normal preamble	RO	1
1.5	Auto-Negotiation Complete	1 = Auto-negotiation process completed 0 = Auto-negotiation process not completed	RO	0
1.4	Remote Fault	1 = Remote fault 0 = No remote fault	RO/LH	0
1.3	Auto-Negotiation Ability	1 = Can perform auto-negotiation 0 = Cannot perform auto-negotiation	RO	1
1.2	Link Status	1 = Link is up 0 = Link is down	RO/LL	0
1.1	Jabber Detect	1 = Jabber detected 0 = Jabber not detected (default is low)	RO/LH	0
1.0	Extended Capability	1 = Supports extended capability registers	RO	1
Register 2h – PHY Identifier 1				
2.15:0	PHY ID Number	Assigned to the 3rd through 18th bits of the Organizationally Unique Identifier (OUI). KENDIN Communication's OUI is 0010A1 (hex).	RO	0022h
Register 3h – PHY Identifier 2				
3.15:10	PHY ID Number	Assigned to the 19th through 24th bits of the Organizationally Unique Identifier (OUI). KENDIN Communication's OUI is 0010A1 (hex).	RO	0001_01
3.9:4	Model Number	Six-bit manufacturer's model number	RO	01_0110
3.3:0	Revision Number	Four-bit manufacturer's revision number	RO	Indicates silicon revision

Register Description (Continued)

Address	Name	Description	Mode ⁽⁶⁾	Default
Register 4h – Auto-Negotiation Advertisement				
4.15	Next Page	1 = Next page capable 0 = No next page capability	RW	0
4.14	Reserved	Reserved	RO	0
4.13	Remote Fault	1 = Remote fault supported 0 = No remote fault	RW	0
4.12	Reserved	Reserved	RO	0
4.11:10	Pause	[00] = No pause [10] = Asymmetric pause [01] = Symmetric pause [11] = Asymmetric and symmetric pause	RW	00
4.9	100Base-T4	1 = T4 capable 0 = No T4 capability	RO	0
4.8	100Base-TX Full-Duplex	1 = 100Mbps full-duplex capable 0 = No 100Mbps full-duplex capability	RW	Set by the SPEED strapping pin. See the Strapping Options section for details.
4.7	100Base-TX Half-Duplex	1 = 100Mbps half-duplex capable 0 = No 100Mbps half-duplex capability	RW	Set by the SPEED strapping pin. See the Strapping Options section for details.
4.6	10Base-T Full-Duplex	1 = 10Mbps full-duplex capable 0 = No 10Mbps full-duplex capability	RW	1
4.5	10Base-T Half-Duplex	1 = 10Mbps half-duplex capable 0 = No 10Mbps half-duplex capability	RW	1
4.4:0	Selector Field	[00001] = IEEE 802.3	RW	0_0001
Register 5h – Auto-Negotiation Link Partner Ability				
5.15	Next Page	1 = Next page capable 0 = No next page capability	RO	0
5.14	Acknowledge	1 = Link code word received from partner 0 = Link code word not yet received	RO	0
5.13	Remote Fault	1 = Remote fault detected 0 = No remote fault	RO	0
5.12	Reserved	Reserved	RO	0
5.11:10	Pause	[00] = No pause [10] = Asymmetric pause [01] = Symmetric pause [11] = Asymmetric and symmetric pause	RO	00
5.9	100Base-T4	1 = T4 capable 0 = No T4 capability	RO	0
5.8	100Base-TX Full-Duplex	1 = 100Mbps full-duplex capable 0 = No 100Mbps full-duplex capability	RO	0

Register Description (Continued)

Address	Name	Description	Mode ⁽⁶⁾	Default
Register 5h – Auto-Negotiation Link Partner Ability				
5.7	100Base-TX Half-Duplex	1 = 100Mbps half-duplex capable 0 = No 100Mbps half-duplex capability	RO	0
5.6	10Base-T Full-Duplex	1 = 10Mbps full-duplex capable 0 = No 10Mbps full-duplex capability	RO	0
5.5	10Base-T Half-Duplex	1 = 10Mbps half-duplex capable 0 = No 10Mbps half-duplex capability	RO	0
5.4:0	Selector Field	[00001] = IEEE 802.3	RO	0_0001
Register 6h – Auto-Negotiation Expansion				
6.15:5	Reserved	Reserved	RO	0000_0000_000
6.4	Parallel Detection Fault	1 = Fault detected by parallel detection 0 = No fault detected by parallel detection	RO/LH	0
6.3	Link Partner Next Page Able	1 = Link partner has next page capability 0 = Link partner does not have next page capability	RO	0
6.2	Next Page Able	1 = Local device has next page capability 0 = Local device does not have next page capability	RO	1
6.1	Page Received	1 = New page received 0 = New page not received yet	RO/LH	0
6.0	Link Partner Auto-Negotiation Able	1 = Link partner has auto-negotiation capability 0 = Link partner does not have auto-negotiation capability	RO	0
Register 7h – Auto-Negotiation Next Page				
7.15	Next Page	1 = Additional next pages will follow 0 = Last page	RW	0
7.14	Reserved	Reserved	RO	0
7.13	Message Page	1 = Message page 0 = Unformatted page	RW	1
7.12	Acknowledge2	1 = Will comply with message 0 = Cannot comply with message	RW	0
7.11	Toggle	1 = Previous value of the transmitted link code word equaled logic 1 0 = Logic 0	RO	0
7.10:0	Message Field	11-bit wide field to encode 2048 messages	RW	000_0000_0001

Register Description (Continued)

Address	Name	Description	Mode ⁽⁶⁾	Default
Register 8h – Link Partner Next Page Ability				
8.15	Next Page	1 = Additional next pages will follow 0 = Last page	RO	0
8.14	Acknowledge	1 = Successful receipt of link word 0 = No successful receipt of link word	RO	0
8.13	Message Page	1 = Message page 0 = Unformatted page	RO	0
8.12	Acknowledge2	1 = Can act on the information 0 = Cannot act on the information	RO	0
8.11	Toggle	1 = Previous value of transmitted link code word equal to logic 0 0 = Previous value of transmitted link code word equal to logic 1	RO	0
8.10:0	Message Field	11-bit wide field to encode 2048 messages	RO	000_0000_0000
Register 10h – Digital Reserved Control				
10.15:5	Reserved	Reserved	RW	0000_0000_000
10.4	PLL Off	1 = Turn PLL off automatically in EDPD mode 0 = Keep PLL on in EDPD mode. See also Register 18h, Bit [11] for EDPD mode	RW	0
10.3:0	Reserved	Reserved	RW	0000
Register 11h – AFE Control 1				
11.15:6	Reserved	Reserved	RW	0000_0000_00
11.5	Slow-Oscillator Mode Enable	Slow-oscillator mode is used to disconnect the input reference crystal/clock on the XI pin and select the on-chip slow oscillator when the KSZ8081MLX device is not in use after power-up. 1 = Enable 0 = Disable This bit automatically sets software power-down to the analog side when enabled.	RW	0
11.4:0	Reserved	Reserved	RW	0_0000
Register 15h – RXER Counter				
15.15:0	RXER Counter	Receive error counter for symbol error frames	RO/SC	0000h

Register Description (Continued)

Address	Name	Description	Mode ⁽⁶⁾	Default
Register 16h – Operation Mode Strap Override				
16.15	Reserved Factory Mode	If TXC (Pin 33) latches in a pull-up value at the de-assertion of reset, write a '0' to this bit to clear Reserved Factory Mode.	RW	Set by the pull-up / pull-down value of TXC (Pin 33).
16.14:11	Reserved	Reserved	RW	000_0
16.10	Reserved	Reserved	RO	0
16.9	B-CAST_OFF Override	1 = Override strap-in for B-CAST_OFF If bit is '1', PHY Address 0 is non-broadcast.	RW	0
16.8	Reserved	Reserved	RW	0
16.7	MII B-to-B Override	1 = Override strap-in for MII back-to-back mode (also set Bit 0 of this register to '1')	RW	0
16.6	Reserved	Reserved	RW	0
16.5	NAND Tree Override	1 = Override strap-in for NAND tree mode	RW	0
16.4:1	Reserved	Reserved	RW	0_000
16.0	MII Override	1 = Override strap-in for MII mode	RW	1
Register 17h – Operation Mode Strap Status				
17.15:13	PHYAD[2:0] Strap- In Status	[000] = Strap to PHY Address 0 [001] = Strap to PHY Address 1 [010] = Strap to PHY Address 2 [011] = Strap to PHY Address 3 [100] = Strap to PHY Address 4 [101] = Strap to PHY Address 5 [110] = Strap to PHY Address 6 [111] = Strap to PHY Address 7	RO	
17.12:10	Reserved	Reserved	RO	
17.9	B-CAST_OFF Strap-In Status	1 = Strap to B-CAST_OFF If bit is '1', PHY Address 0 is non-broadcast.	RO	
17.8	Reserved	Reserved	RO	
17.7	MII B-to-B Strap-In Status	1 = Strap to MII back-to-back mode	RO	
17.6	Reserved	Reserved	RO	
17.5	NAND Tree Strap- In Status	1 = Strap to NAND tree mode	RO	
17.4:1	Reserved	Reserved	RO	
17.0	MII Strap-In Status	1 = Strap to MII mode	RO	

Register Description (Continued)

Address	Name	Description	Mode ⁽⁶⁾	Default
Register 18h – Expanded Control				
18.15:12	Reserved	Reserved	RW	0000
18.11	EDPD Disabled	Energy-detect power-down mode 1 = Disable 0 = Enable See also Register 10h, Bit [4] for PLL off.	RW	1
18.10	100Base-TX Latency	1 = MII output is random latency 0 = MII output is fixed latency For both settings, all bytes of received preamble are passed to the MII output.	RW	0
18.9:7	Reserved	Reserved	RW	00_0
18.6	10Base-T Preamble Restore	1 = Restore received preamble to MII output 0 = Remove all seven bytes of preamble before sending frame (starting with SFD) to MII output	RW	0
18.5:0	Reserved	Reserved	RW	00_0000
Register 1Bh – Interrupt Control/Status				
1B.15	Jabber Interrupt Enable	1 = Enable jabber interrupt 0 = Disable jabber interrupt	RW	0
1B.14	Receive Error Interrupt Enable	1 = Enable receive error interrupt 0 = Disable receive error interrupt	RW	0
1B.13	Page Received Interrupt Enable	1 = Enable page received interrupt 0 = Disable page received interrupt	RW	0
1B.12	Parallel Detect Fault Interrupt Enable	1 = Enable parallel detect fault interrupt 0 = Disable parallel detect fault interrupt	RW	0
1B.11	Link Partner Acknowledge Interrupt Enable	1 = Enable link partner acknowledge interrupt 0 = Disable link partner acknowledge interrupt	RW	0
1B.10	Link-Down Interrupt Enable	1 = Enable link-down interrupt 0 = Disable link-down interrupt	RW	0
1B.9	Remote Fault Interrupt Enable	1 = Enable remote fault interrupt 0 = Disable remote fault interrupt	RW	0
1B.8	Link-Up Interrupt Enable	1 = Enable link-up interrupt 0 = Disable link-up interrupt	RW	0
1B.7	Jabber Interrupt	1 = Jabber occurred 0 = Jabber did not occur	RO/SC	0
1B.6	Receive Error Interrupt	1 = Receive error occurred 0 = Receive error did not occur	RO/SC	0
1B.5	Page Receive Interrupt	1 = Page receive occurred 0 = Page receive did not occur	RO/SC	0

Register Description (Continued)

Address	Name	Description	Mode ⁽⁶⁾	Default
Register 1Bh – Interrupt Control/Status (Continued)				
1B.4	Parallel Detect Fault Interrupt	1 = Parallel detect fault occurred 0 = Parallel detect fault did not occur	RO/SC	0
1B.3	Link Partner Acknowledge Interrupt	1 = Link partner acknowledge occurred 0 = Link partner acknowledge did not occur	RO/SC	0
1B.2	Link-Down Interrupt	1 = Link-down occurred 0 = Link-down did not occur	RO/SC	0
1B.1	Remote Fault Interrupt	1 = Remote fault occurred 0 = Remote fault did not occur	RO/SC	0
1B.0	Link-Up Interrupt	1 = Link-up occurred 0 = Link-up did not occur	RO/SC	0
Register 1Dh – LinkMD Control/Status				
1D.15	Cable Diagnostic Test Enable	1 = Enable cable diagnostic test. After test has completed, this bit is self-cleared. 0 = Indicates cable diagnostic test (if enabled) has completed and the status information is valid for read.	RW/SC	0
1D.14:13	Cable Diagnostic Test Result	[00] = Normal condition [01] = Open condition has been detected in cable [10] = Short condition has been detected in cable [11] = Cable diagnostic test has failed	RO	00
1D.12	Short Cable Indicator	1 = Short cable (<10 meter) has been detected by LinkMD	RO	0
1D.11:9	Reserved	Reserved	RW	000
1D.8:0	Cable Fault Counter	Distance to fault	RO	0_0000_0000
Register 1Eh – PHY Control 1				
1E.15:10	Reserved	Reserved	RO	0000_00
1E.9	Enable Pause (Flow Control)	1 = Flow control capable 0 = No flow control capability	RO	0
1E.8	Link Status	1 = Link is up 0 = Link is down	RO	0
1E.7	Polarity Status	1 = Polarity is reversed 0 = Polarity is not reversed	RO	
1E.6	Reserved	Reserved	RO	0
1E.5	MDI/MDI-X State	1 = MDI-X 0 = MDI	RO	

Register Description (Continued)

Address	Name	Description	Mode ⁽⁶⁾	Default
Register 1Eh – PHY Control 1 (Continued)				
1E.4	Energy Detect	1 = Presence of signal on receive differential pair 0 = No signal detected on receive differential pair	RO	0
1E.3	PHY Isolate	1 = PHY in isolate mode 0 = PHY in normal operation	RW	0
1E.2:0	Operation Mode Indication	[000] = Still in auto-negotiation [001] = 10Base-T half-duplex [010] = 100Base-TX half-duplex [011] = Reserved [100] = Reserved [101] = 10Base-T full-duplex [110] = 100Base-TX full-duplex [111] = Reserved	RO	000
Register 1Fh – PHY Control 2				
1F.15	HP_MDIX	1 = HP Auto MDI/MDI-X mode 0 = Micrel Auto MDI/MDI-X mode	RW	1
1F.14	MDI/MDI-X Select	When Auto MDI/MDI-X is disabled, 1 = MDI-X mode Transmit on RXP,RXM (Pins 10, 9) and Receive on TXP, TXM (Pins 12, 11) 0 = MDI mode Transmit on TXP, TXM (Pins 12, 11) and Receive on RXP,RXM (Pins 10, 9)	RW	0
1F.13	Pair Swap Disable	1 = Disable Auto MDI/MDI-X 0 = Enable Auto MDI/MDI-X	RW	0
1F.12	Reserved	Reserved	RW	0
1F.11	Force Link	1 = Force link pass 0 = Normal link operation This bit bypasses the control logic and allows the transmitter to send a pattern even if there is no link.	RW	0
1F.10	Power Saving	1 = Enable power saving 0 = Disable power saving	RW	0
1F.9	Interrupt Level	1 = Interrupt pin active high 0 = Interrupt pin active low	RW	0
1F.8	Enable Jabber	1 = Enable jabber counter 0 = Disable jabber counter	RW	1
1F.7:6	Reserved	Reserved	RW	00

Register Description (Continued)

Address	Name	Description	Mode ⁽⁶⁾	Default
Register 1Fh – PHY Control 2 (Continued)				
1F.5:4	LED Mode	[00] = LED1: Speed LED0: Link/Activity [01] = LED1: Activity LED0: Link [10], [11] = Reserved	RW	00
1F.3	Disable Transmitter	1 = Disable transmitter 0 = Enable transmitter	RW	0
1F.2	Remote Loopback	1 = Remote (analog) loopback is enabled 0 = Normal mode	RW	0
1F.1	Enable SQE Test	1 = Enable SQE test 0 = Disable SQE test	RW	0
1F.0	Disable Data Scrambling	1 = Disable scrambler 0 = Enable scrambler	RW	0

Absolute Maximum Ratings⁽⁷⁾

Supply Voltage (V_{IN})	
($V_{DD_1.2}$)	-0.5V to +1.8V
($V_{DDIO}, V_{DDA_3.3}$)	-0.5V to +5.0V
Input Voltage (all inputs)	-0.5V to +5.0V
Output Voltage (all outputs)	-0.5V to +5.0V
Lead Temperature (soldering, 10s).....	260°C
Storage Temperature (T_s)	-55°C to +150°C

Operating Ratings⁽⁸⁾

Supply Voltage	
($V_{DDIO_3.3}, V_{DDA_3.3}$)	+3.135V to +3.465V
($V_{DDIO_2.5}$).....	+2.375V to +2.625V
($V_{DDIO_1.8}$).....	+1.710V to +1.890V
Ambient Temperature	
(T_A , Commercial).....	0°C to +70°C
(T_A , Industrial)	-40°C to +85°C
Maximum Junction Temperature (T_J maximum)	125°C
Thermal Resistance (θ_{JA})	76°C/W
Thermal Resistance (θ_{JC})	15°C/W

Electrical Characteristics⁽⁹⁾

Symbol	Parameter	Condition	Min.	Typ.	Max.	Units
Supply Current ($V_{DDIO}, V_{DDA_3.3} = 3.3V$)⁽¹⁰⁾						
$I_{DD1_3.3V}$	10Base-T	Full-duplex traffic @ 100% utilization		41		mA
$I_{DD2_3.3V}$	100Base-TX	Full-duplex traffic @ 100% utilization		47		mA
$I_{DD3_3.3V}$	EDPD Mode	Ethernet cable disconnected (reg. 18h.11 = 0)		20		mA
$I_{DD4_3.3V}$	Power-Down Mode	Software power-down (reg. 0h.11 = 1)		4		mA
CMOS Level Inputs						
V_{IH}	Input High Voltage	$V_{DDIO} = 3.3V$	2.0			V
		$V_{DDIO} = 2.5V$	1.8			
		$V_{DDIO} = 1.8V$	1.3			
V_{IL}	Input Low Voltage	$V_{DDIO} = 3.3V$			0.8	V
		$V_{DDIO} = 2.5V$			0.7	
		$V_{DDIO} = 1.8V$			0.5	
$ I_{IN} $	Input Current	$V_{IN} = GND \sim V_{DDIO}$			10	μA
CMOS Level Outputs						
V_{OH}	Output High Voltage	$V_{DDIO} = 3.3V$	2.4			V
		$V_{DDIO} = 2.5V$	2.0			
		$V_{DDIO} = 1.8V$	1.5			
V_{OL}	Output Low Voltage	$V_{DDIO} = 3.3V$			0.4	V
		$V_{DDIO} = 2.5V$			0.4	
		$V_{DDIO} = 1.8V$			0.3	
$ I_{OZ} $	Output Tri-State Leakage				10	μA
LED Outputs						
I_{LED}	Output Drive Current	Each LED pin (LED0, LED1)		8		mA

Notes:

- Exceeding the absolute maximum rating can damage the device. Stresses greater than the absolute maximum rating can cause permanent damage to the device. Operation of the device at these or any other conditions above those specified in the operating sections of this specification is not implied. Maximum conditions for extended periods may affect reliability.
- The device is not guaranteed to function outside its operating rating.
- $T_A = 25^\circ C$. Specification is for packaged product only.
- Current consumption is for the single 3.3V supply KSZ8081MLX device only, and includes the transmit driver current and the 1.2V supply voltage ($V_{DD_1.2}$) that are supplied by the KSZ8081MLX.

Electrical Characteristics⁽⁹⁾ (Continued)

Symbol	Parameter	Condition	Min.	Typ.	Max.	Units
All Pull-Up/Pull-Down Pins (including strapping pins)						
pu	Internal Pull-Up Resistance	$V_{DDIO} = 3.3V$	30	45	73	k Ω
		$V_{DDIO} = 2.5V$	39	61	102	
		$V_{DDIO} = 1.8V$	48	99	178	
pd	Internal Pull-Down Resistance	$V_{DDIO} = 3.3V$	26	43	79	k Ω
		$V_{DDIO} = 2.5V$	34	59	113	
		$V_{DDIO} = 1.8V$	53	99	200	
100Base-TX Transmit (measured differentially after 1:1 transformer)						
V_O	Peak Differential Output Voltage	100 Ω termination across differential output	0.95		1.05	V
V_{IMB}	Output Voltage Imbalance	100 Ω termination across differential output			2	%
t_r, t_f	Rise/Fall Time		3		5	ns
	Rise/Fall Time Imbalance		0		0.5	ns
	Duty Cycle Distortion				± 0.25	ns
	Overshoot				5	%
	Output Jitter	Peak-to-peak		0.7		ns
10Base-T Transmit (measured differentially after 1:1 transformer)						
V_P	Peak Differential Output Voltage	100 Ω termination across differential output	2.2		2.8	V
	Jitter Added	Peak-to-peak			3.5	ns
t_r, t_f	Rise/Fall Time			25		ns
10Base-T Receive						
V_{SQ}	Squelch Threshold	5MHz square wave		400		mV
Transmitter – Drive Setting						
V_{SET}	Reference Voltage of I_{SET}	$R(I_{SET}) = 6.49k\Omega$		0.65		V
100Mbps Mode – Industrial Applications Parameters						
	Clock Phase Delay – XI Input to MII TXC Output	XI (25MHz clock input) to MII TXC (25MHz clock output) delay, referenced to rising edges of both clocks.	15	20	25	ns
t_{llr}	Link Loss Reaction (Indication) Time	Link loss detected at receive differential inputs to PHY signal indication time for each of the following: 1. For LED mode 00, Speed LED output changes from low (100Mbps) to high (10Mbps, default state for link-down). 2. For LED mode 01, Link LED output changes from low (link-up) to high (link-down). 3. INTRP pin asserts for link-down status change.		4.4		μs

Timing Diagrams

MII SQE Timing (10Base-T)

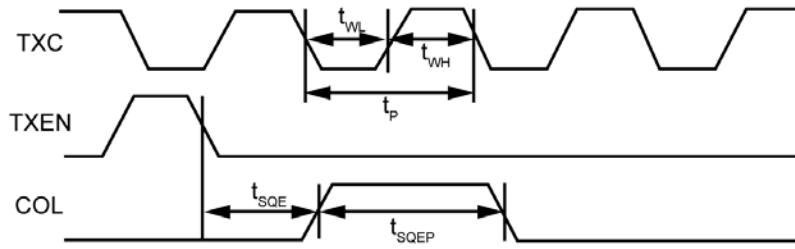

Figure 9. MII SQE Timing (10Base-T)

Table 10. MII SQE Timing (10Base-T) Parameters

Timing Parameter	Description	Min.	Typ.	Max.	Unit
t_P	TXC period		400		ns
t_{WL}	TXC pulse width low		200		ns
t_{WH}	TXC pulse width high		200		ns
t_{SQE}	COL (SQE) delay after TXEN de-asserted		2.2		μ s
t_{SQEP}	COL (SQE) pulse duration		1.0		μ s

MII Transmit Timing (10Base-T)

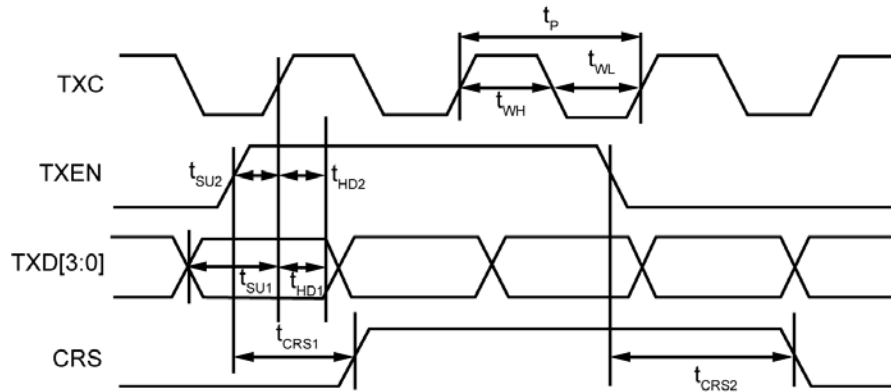

Figure 10. MII Transmit Timing (10Base-T)

Table 11. MII Transmit Timing (10Base-T) Parameters

Timing Parameter	Description	Min.	Typ.	Max.	Unit
t_p	TXC period		400		ns
t_{WL}	TXC pulse width low		200		ns
t_{WH}	TXC pulse width high		200		ns
t_{SU1}	TXD[3:0] setup to rising edge of TXC	120			ns
t_{SU2}	TXEN setup to rising edge of TXC	120			ns
t_{HD1}	TXD[3:0] hold from rising edge of TXC	0			ns
t_{HD2}	TXEN hold from rising edge of TXC	0			ns
t_{CRS1}	TXEN high to CRS asserted latency		600		ns
t_{CRS2}	TXEN low to CRS de-asserted latency		1.0		μ s

MII Receive Timing (10Base-T)

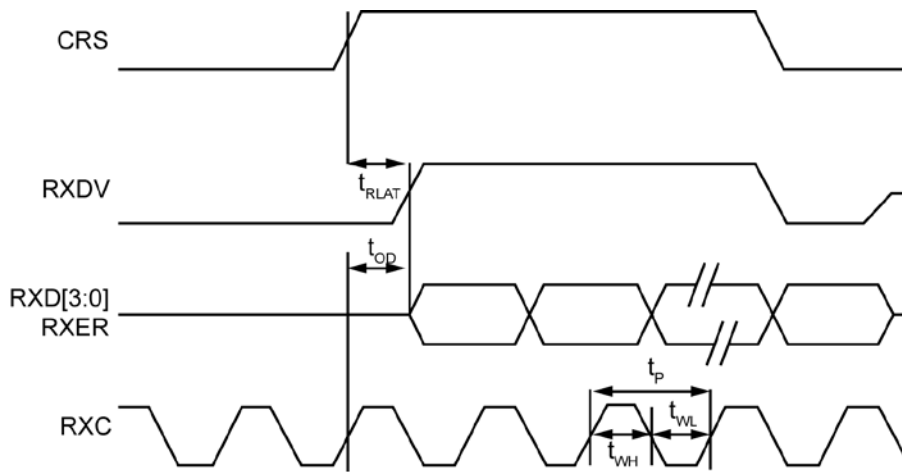

Figure 11. MII Receive Timing (10Base-T)

Table 12. MII Receive Timing (10Base-T) Parameters

Timing Parameter	Description	Min.	Typ.	Max.	Unit
t_P	RXC period		400		ns
t_{WL}	RXC pulse width low		200		ns
t_{WH}	RXC pulse width high		200		ns
t_{OD}	(RXDV, RXD[3:0], RXER) output delay from rising edge of RXC		205		ns
t_{RLAT}	CRS to (RXDV, RXD[3:0]) latency		7.2		μ s

MII Transmit Timing (100Base-TX)

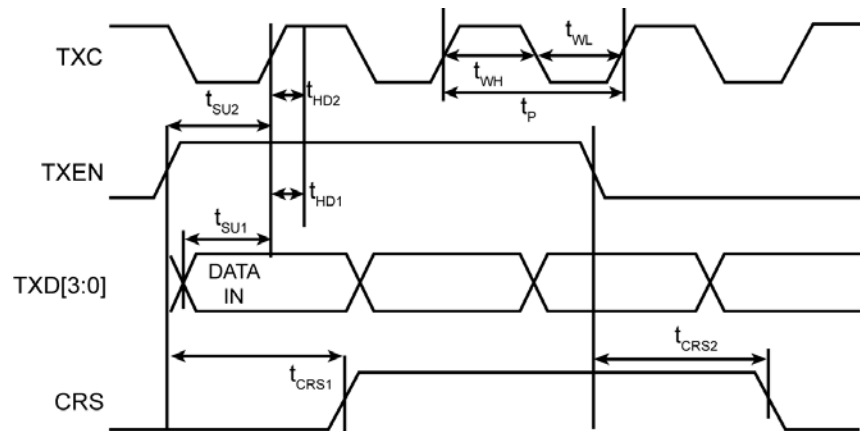

Figure 12. MII Transmit Timing (100Base-TX)

Table 13. MII Transmit Timing (100Base-TX) Parameters

Timing Parameter	Description	Min.	Typ.	Max.	Unit
t_P	TXC period		40		ns
t_{WL}	TXC pulse width low		20		ns
t_{WH}	TXC pulse width high		20		ns
t_{SU1}	TXD[3:0] setup to rising edge of TXC	10			ns
t_{SU2}	TXEN setup to rising edge of TXC	10			ns
t_{HD1}	TXD[3:0] hold from rising edge of TXC	0			ns
t_{HD2}	TXEN hold from rising edge of TXC	0			ns
t_{CRS1}	TXEN high to CRS asserted latency		72		ns
t_{CRS2}	TXEN low to CRS de-asserted latency		72		ns

MII Receive Timing (100Base-TX)

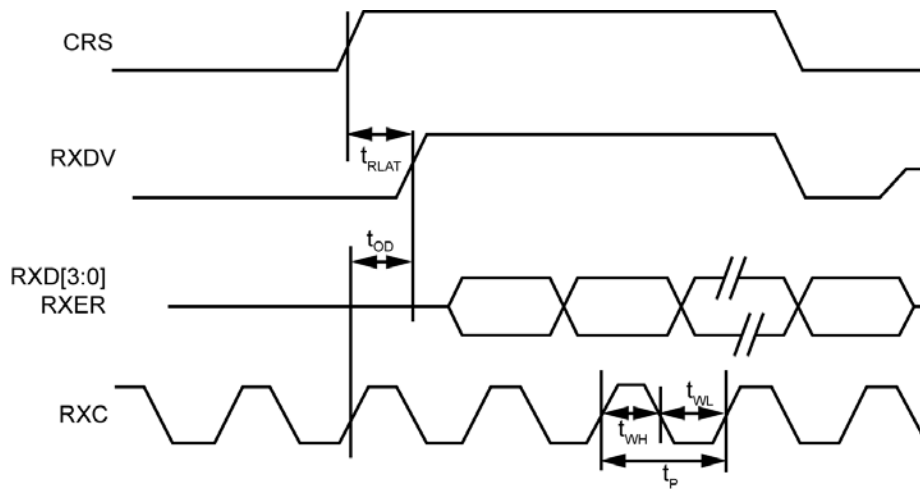

Figure 13. MII Receive Timing (100Base-TX)

Table 14. MII Receive Timing (100Base-TX) Parameters

Timing Parameter	Description	Min.	Typ.	Max.	Unit
t_P	RXC period		40		ns
t_{WL}	RXC pulse width low		20		ns
t_{WH}	RXC pulse width high		20		ns
t_{OD}	(RXDV, RXD[3:0], RXER) output delay from rising edge of RXC		25		ns
t_{RLAT}	CRS to (RXDV, RXD[3:0]) latency		170		ns

Auto-Negotiation Timing

AUTO-NEGOTIATION
FAST LINK PULSE (FLP) TIMING

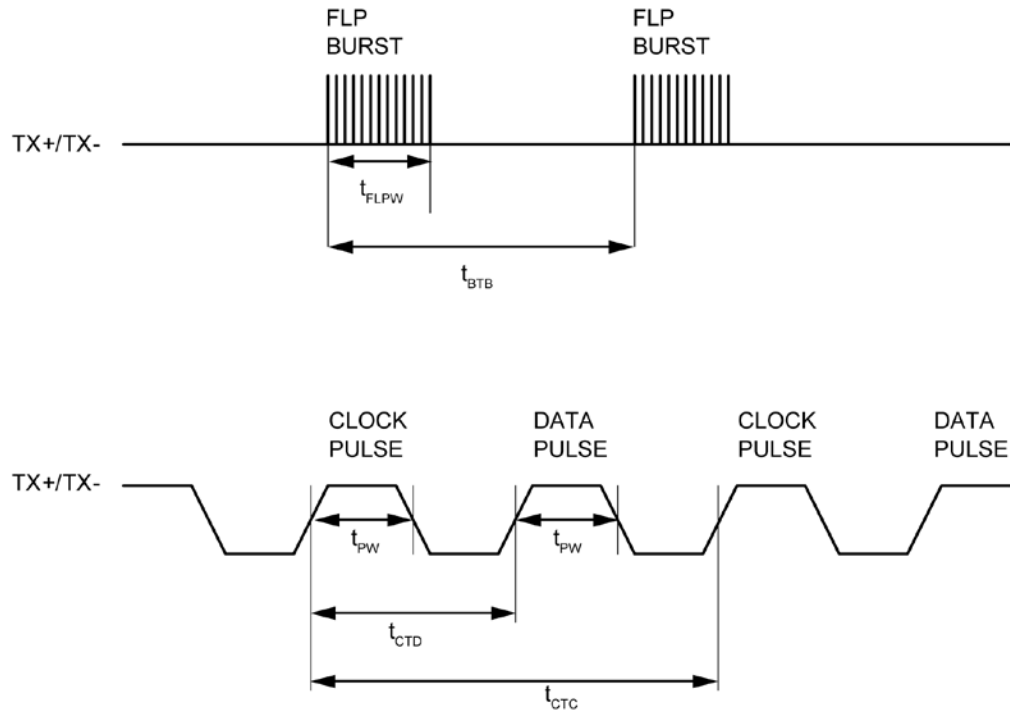

Figure 14. Auto-Negotiation Fast Link Pulse (FLP) Timing

Table 15. Auto-Negotiation Fast Link Pulse (FLP) Timing Parameters

Timing Parameter	Description	Min.	Typ.	Max.	Units
t_{BTB}	FLP burst to FLP burst	8	16	24	ms
t_{FLPW}	FLP burst width		2		ms
t_{PW}	Clock/Data pulse width		100		ns
t_{CTD}	Clock pulse to data pulse	55.5	64	69.5	μ s
t_{CTC}	Clock pulse to clock pulse	111	128	139	μ s
	Number of clock/data pulses per FLP burst	17		33	

MDC/MDIO Timing

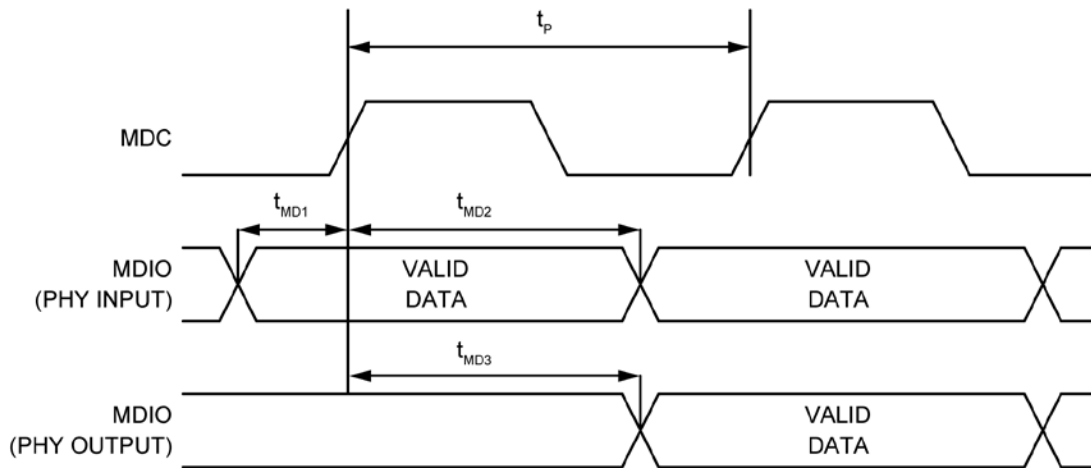

Figure 15. MDC/MDIO Timing

Table 16. MDC/MDIO Timing Parameters

Timing Parameter	Description	Min.	Typ.	Max.	Unit
t_P	MDC period		400		ns
t_{MD1}	MDIO (PHY input) setup to rising edge of MDC	10			ns
t_{MD2}	MDIO (PHY input) hold from rising edge of MDC	4			ns
t_{MD3}	MDIO (PHY output) delay from rising edge of MDC	5			ns

Power-Up/Reset Timing

The KSZ8081MLX reset timing requirement is summarized in [Figure 16](#) and [Table 17](#).

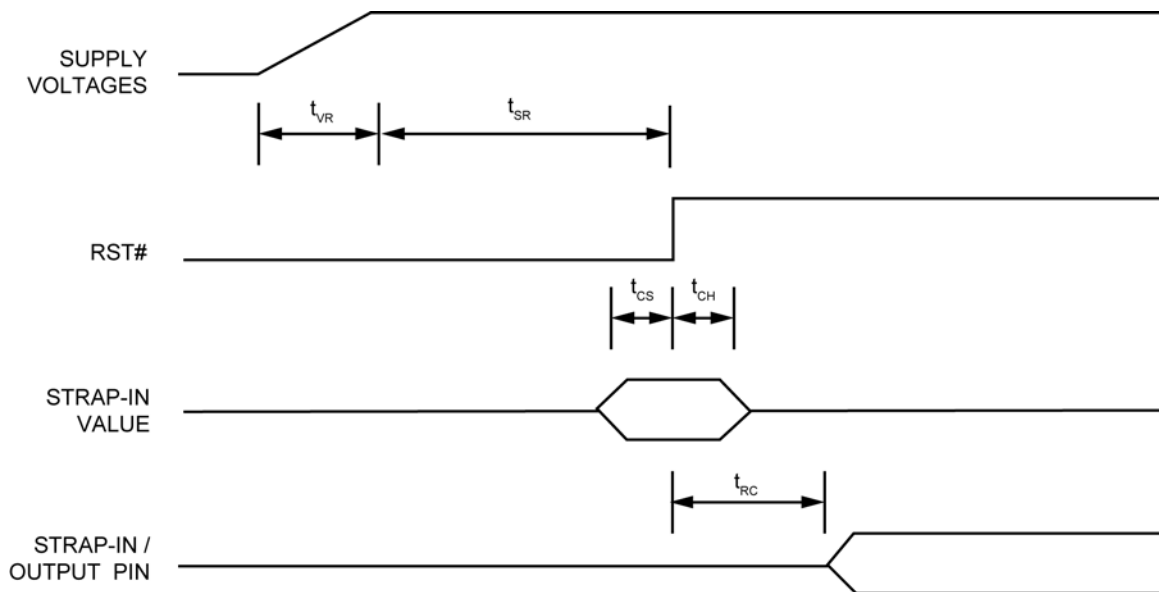

Figure 16. Power-Up/Reset Timing

Table 17. Power-Up/Reset Timing Parameters

Parameter	Description	Min.	Max.	Units
t_{VR}	Supply voltage (V_{DDIO} , $V_{DDA_{3.3}}$) rise time	300		μs
t_{SR}	Stable supply voltage (V_{DDIO} , $V_{DDA_{3.3}}$) to reset high	10		ms
t_{CS}	Configuration setup time	5		ns
t_{CH}	Configuration hold time	5		ns
t_{RC}	Reset to strap-in pin output	6		ns

The supply voltage (V_{DDIO} and $V_{DDA_{3.3}}$) power-up waveform should be monotonic. The 300 μs minimum rise time is from 10% to 90%.

For warm reset, the reset (RST#) pin should be asserted low for a minimum of 500 μs . The strap-in pin values are read and updated at the de-assertion of reset.

After the de-assertion of reset, wait a minimum of 100 μs before starting programming on the MIIM (MDC/MDIO) interface.

Reset Circuit

Figure 17 shows a reset circuit recommended for powering up the KSZ8081MLX if reset is triggered by the power supply.

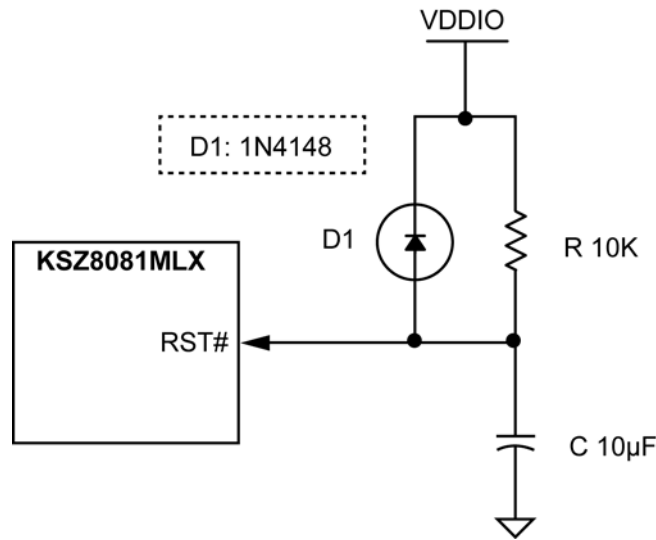

Figure 17. Recommended Reset Circuit

Figure 18 shows a reset circuit recommended for applications where reset is driven by another device (for example, the CPU or an FPGA). At power-on-reset, R, C, and D1 provide the necessary ramp rise time to reset the KSZ8081MLX device. The RST_OUT_n from the CPU/FPGA provides the warm reset after power-up.

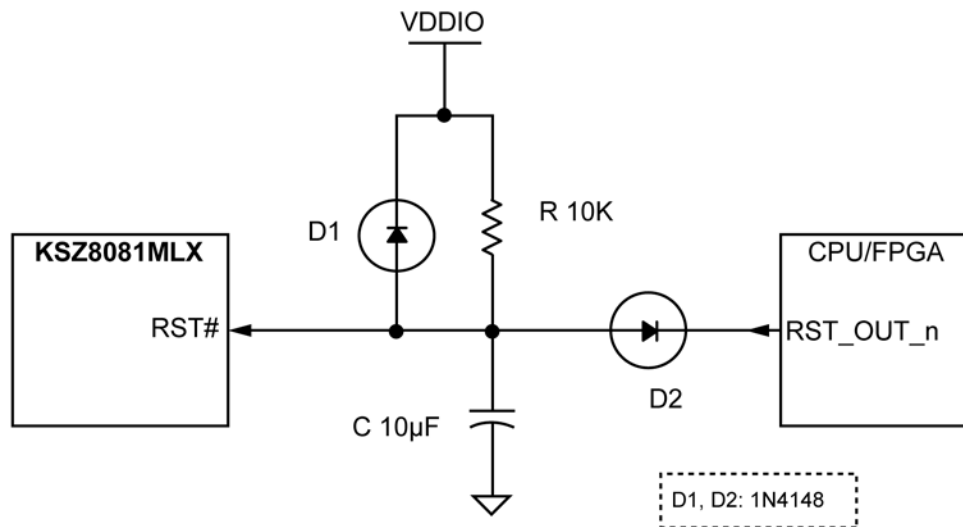

Figure 18. Recommended Reset Circuit for Interfacing with CPU/FPGA Reset Output

Reference Circuits – LED Strap-In Pins

The pull-up, float, and pull-down reference circuits for the LED1/SPEED and LED0/NWAYEN strapping pins are shown in Figure 19 for 3.3V and 2.5V VDDIO.

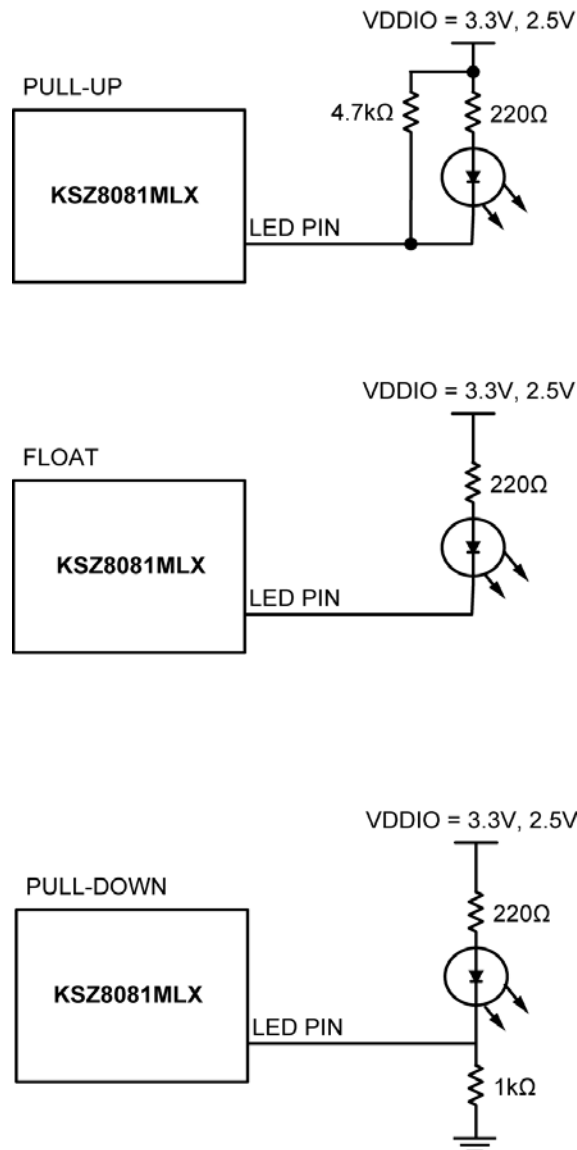

Figure 19. Reference Circuits for LED Strapping Pins

For 1.8V VDDIO, LED indication support is not recommended due to the low voltage. Without the LED indicator, the SPEED and NWAYEN strapping pins are functional with a 4.7kΩ pull-up to 1.8V VDDIO or float for a value of '1', and with 1.0kΩ pull-down to ground for a value of '0'.

Reference Clock – Connection and Selection

A crystal or external clock source, such as an oscillator, is used to provide the reference clock for the KSZ8081MLX. For the KSZ8081MLX in all operating modes, the reference clock is 25MHz. The reference clock connections to XI (Pin 15) and XO (Pin 14), and the reference clock selection criteria, are provided in [Figure 20](#) and [Table 18](#).

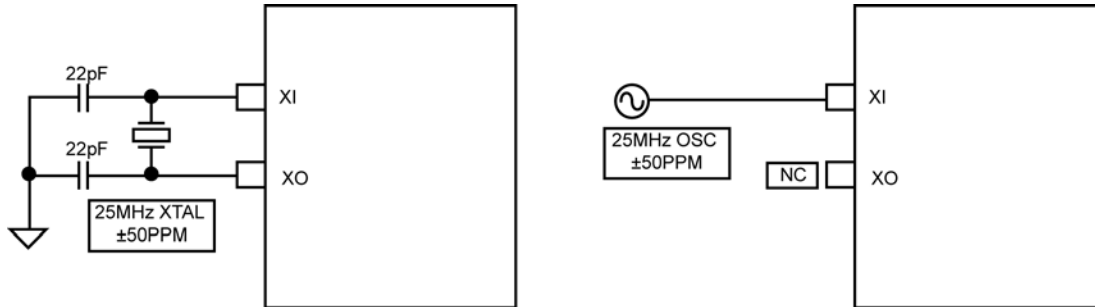

Figure 20. 25MHz Crystal/Oscillator Reference Clock Connection

Table 18. 25MHz Crystal / Reference Clock Selection Criteria

Characteristics	Value	Units
Frequency	25	MHz
Frequency tolerance (maximum)	±50	ppm
Crystal series resistance (typical)	40	Ω
Crystal load capacitance (typical)	16	pF

Magnetic – Connection and Selection

A 1:1 isolation transformer is required at the line interface. Use one with integrated common-mode chokes for designs exceeding FCC requirements.

The KSZ8081MLX design incorporates voltage-mode transmit drivers and on-chip terminations.

With the voltage-mode implementation, the transmit drivers supply the common-mode voltages to the two differential pairs. Therefore, the two transformer center tap pins on the KSZ8081MLX side should not be connected to any power supply source on the board; instead, the center tap pins should be separated from one another and connected through separate 0.1µF common-mode capacitors to ground. Separation is required because the common-mode voltage is different between transmitting and receiving differential pairs.

Figure 21 shows the typical magnetic interface circuit for the KSZ8081MLX.

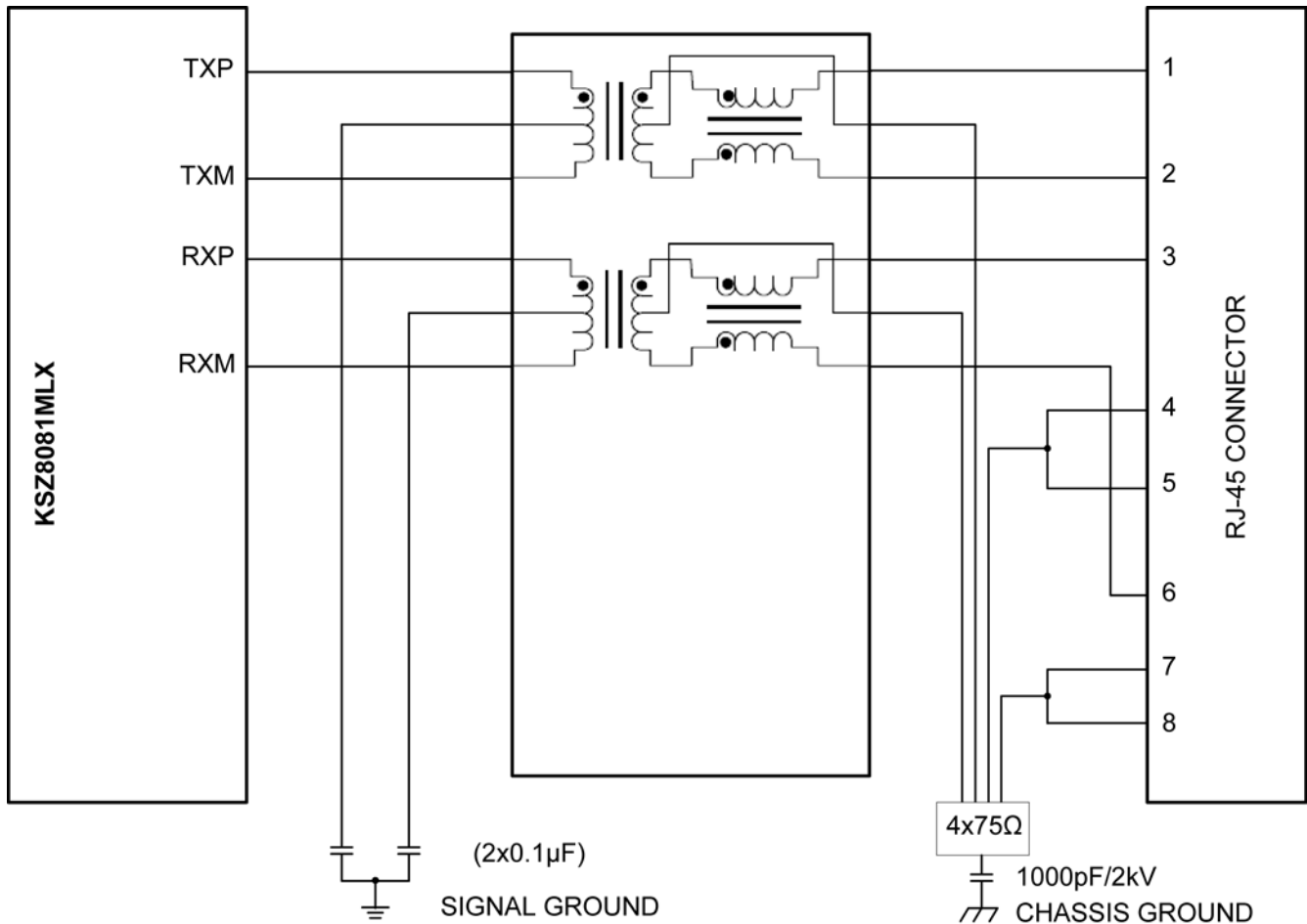

Figure 21. Typical Magnetic Interface Circuit

Table 19 lists recommended magnetic characteristics.

Table 19. Magnetics Selection Criteria

Parameter	Value	Test Condition
Turns ratio	1 CT : 1 CT	
Open-circuit inductance (min.)	350 μ H	100mV, 100kHz, 8mA
Insertion loss (typ.)	-1.1dB	100kHz to 100MHz
HIPOT (min.)	1500Vrms	

Table 20 is a list of compatible single-port magnetics with separated transformer center tap pins on the PHY chip side that can be used with the KSZ8081MLX.

Table 20. Compatible Single-Port 10/100 Magnetics

Manufacturer	Part Number	Temperature Range	Magnetic + RJ-45
Bel Fuse	S558-5999-U7	0°C to 70°C	No
Bel Fuse	SI-46001-F	0°C to 70°C	Yes
Bel Fuse	SI-50170-F	0°C to 70°C	Yes
Delta	LF8505	0°C to 70°C	No
HALO	HFJ11-2450E	0°C to 70°C	Yes
HALO	TG110-E055N5	-40°C to 85°C	No
LANKom	LF-H41S-1	0°C to 70°C	No
Pulse	H1102	0°C to 70°C	No
Pulse	H1260	0°C to 70°C	No
Pulse	HX1188	-40°C to 85°C	No
Pulse	J00-0014	0°C to 70°C	Yes
Pulse	JX0011D21NL	-40°C to 85°C	Yes
TDK	TLA-6T718A	0°C to 70°C	Yes
Transpower	HB726	0°C to 70°C	No
Würth/Midcom	000-7090-37R-LF1	-40°C to 85°C	No

Package Information and Recommended Landing Pattern⁽¹¹⁾

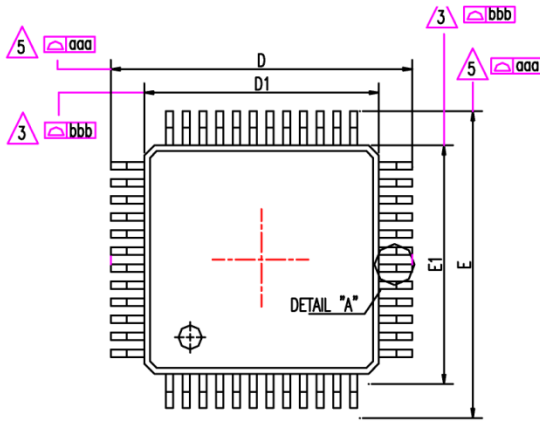

TOP VIEW

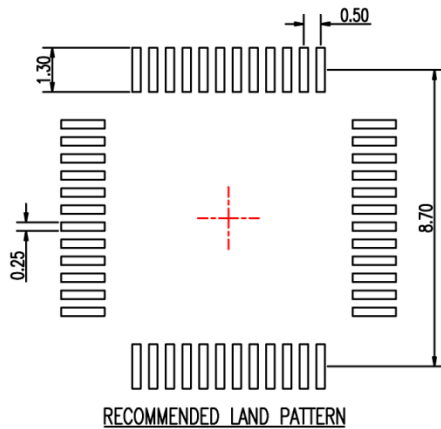

RECOMMENDED LAND PATTERN

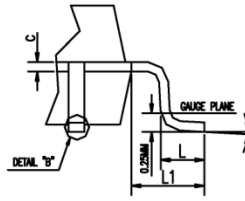

SIDE VIEW 1

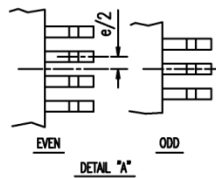

DETAIL "A"

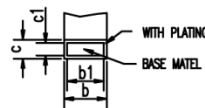

DETAIL "B"

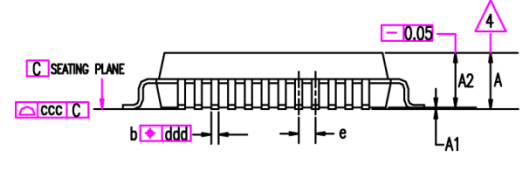

SIDE VIEW 2

SYMBOL	DIMENSION IN MM		
	MIN.	NOM.	MAX.
A	-	-	1.60
A1	0.05	-	0.15
A2	1.35	1.40	1.45
D	9.00 BSC		
D1	7.00 BSC		
E	9.00 BSC		
E1	7.00 BSC		
c	0.09	-	0.20
c1	0.09	-	0.16
L	0.45	0.60	0.75
L1	1.00 REF.		
θ	0	3.5	7

N	b (MM)			b1 (MM)			e (MM)		
	MIN.	NOM.	MAX.	MIN.	NOM.	MAX.	MIN.	NOM.	MAX.
48L	0.17	0.22	0.27	0.17	0.20	0.23	0.50 BSC.		

TOLERANCE OF FORM AND POSITION	
aaa	0.20
bbb	0.20
ccc	0.08
ddd	0.08

NOTES:

1. ALL DIMENSIONS ARE IN MM.
2. REFER TO JEDEC STANDARD MS-026 BBC.
3. DIMENSIONS "D1" AND "E1" DO NOT INCLUDE MOLD PROTRUSIONS. ALLOWABLE PROTRUSION IS 0.25mm PER SIDE. "D1" AND "E1" ARE MAXIMUM PLASTIC BODY SIZE DIMENSIONS INCLUDING MOLD MISMATCH.
4. A1 IS DEFINED AS THE DISTANCE FROM THE SEATING PLANE TO THE LOWEST POINT OF THE PACKAGE BODY.
5. TO BE DETERMINED AT SEATING DATUM PLANE C.
6. "aaa" IS THE BILATERAL PROFILE TOLERANCE THAT CONTROLS THE POSITION OF THE PLASTIC BODY SIDES. THE CENTER OF THE PROFILE ZONES ARE DEFINED BY THE BASIC DIMENSIONS "D" AND "E".
7. "bbb" THE TOLERANCE THAT CONTROLS THE POSITION OF THE ENTIRE TERMINAL PATTERN WITH RESPECT TO DATUM'S A AND B. THE CENTER OF THE TOLERENCE ZONE FOR EACH TERMINAL IS DEFINED BY THE BASIC DIMENSION "e" RELATED TO DATUM A AND B.
8. "ccc" THE TOLERANCE RELATED TO THE SEATING PLANE IN WHICH THE TOP SURFACE OF THE PACKAGE MUST BE LOCATED.
9. "ddd" THE TOLERANCE THAT CONTROLS THE POSITION OF THE TERMINALS TO EACH OTHER. THE CENTER OF THE PROFILE ZONES ARE DETERMINED BY THE BASIC DIMENSION "e".
10. THIS DOCUMENT IS FOR AUTOMOTIVE PRODUCT USE ONLY.

48-Pin 7mm x 7mm LQFP (MM)

Note:

11. Package information is correct as of the publication date. For updates and most current information, go to www.micrel.com.

MICREL, INC. 2180 FORTUNE DRIVE SAN JOSE, CA 95131 USA
TEL +1 (408) 944-0800 FAX +1 (408) 474-1000 WEB <http://www.micrel.com>

Micrel, Inc. is a leading global manufacturer of IC solutions for the worldwide high performance linear and power, LAN, and timing & communications markets. The Company's products include advanced mixed-signal, analog & power semiconductors; high-performance communication, clock management, MEMs-based clock oscillators & crystal-less clock generators, Ethernet switches, and physical layer transceiver ICs. Company customers include leading manufacturers of enterprise, consumer, industrial, mobile, telecommunications, automotive, and computer products. Corporation headquarters and state-of-the-art wafer fabrication facilities are located in San Jose, CA, with regional sales and support offices and advanced technology design centers situated throughout the Americas, Europe, and Asia. Additionally, the Company maintains an extensive network of distributors and reps worldwide.

Micrel makes no representations or warranties with respect to the accuracy or completeness of the information furnished in this datasheet. This information is not intended as a warranty and Micrel does not assume responsibility for its use. Micrel reserves the right to change circuitry, specifications and descriptions at any time without notice. No license, whether express, implied, arising by estoppel or otherwise, to any intellectual property rights is granted by this document. Except as provided in Micrel's terms and conditions of sale for such products, Micrel assumes no liability whatsoever, and Micrel disclaims any express or implied warranty relating to the sale and/or use of Micrel products including liability or warranties relating to fitness for a particular purpose, merchantability, or infringement of any patent, copyright, or other intellectual property right.

Micrel Products are not designed or authorized for use as components in life support appliances, devices or systems where malfunction of a product can reasonably be expected to result in personal injury. Life support devices or systems are devices or systems that (a) are intended for surgical implant into the body or (b) support or sustain life, and whose failure to perform can be reasonably expected to result in a significant injury to the user. A Purchaser's use or sale of Micrel Products for use in life support appliances, devices or systems is a Purchaser's own risk and Purchaser agrees to fully indemnify Micrel for any damages resulting from such use or sale.

© 2012 Micrel, Incorporated.

Mouser Electronics

Authorized Distributor

Click to View Pricing, Inventory, Delivery & Lifecycle Information:

[Micrel:](#)

[KSZ8081MLXIA](#) [KSZ8081MLXCA TR](#) [KSZ8081MLXCA](#) [KSZ8081MLXIA TR](#) [KSZ8081MLX-EVAL](#)