

General Description

The MIC4043 is a shunt regulator optimized for secondary-side regulation in low-voltage power supplies. Featuring an output stage guaranteed to swing within 400mV of ground, the MIC4043 can be used in power supplies operating down to 1.8V, even with optoisolators requiring greater than 1.2V of headroom.

In power supply applications, the MIC4043 normally drives the LED of an optically isolated feedback circuit. The MIC4043 monitors a resistively-divided output voltage and sinks error current through the optoisolator's LED (secondary side); the optoisolator's transistor (primary side) provides this signal to the controller's feedback input. The MIC4043 is also practical for other voltage-monitoring applications requiring an open-collector output.

The MIC4043 replaces conventional '431-type shunt regulators to allow low-voltage applications where there is inadequate headroom for a 2.5V regulator in series with an optoisolator. Replacing '431-type devices requires only a minor change to the way that the resistive-divider values are calculated.

Features

- Ideal for 1.8V switching converters
- Low-voltage operation
400mV maximum saturation over operating temperature range
- Easy to use
voltage in, current out
- 2% voltage tolerance over operating temperature range

Applications

- Optically isolated low-voltage power supplies
- Low-voltage discrete regulator control

Typical Application

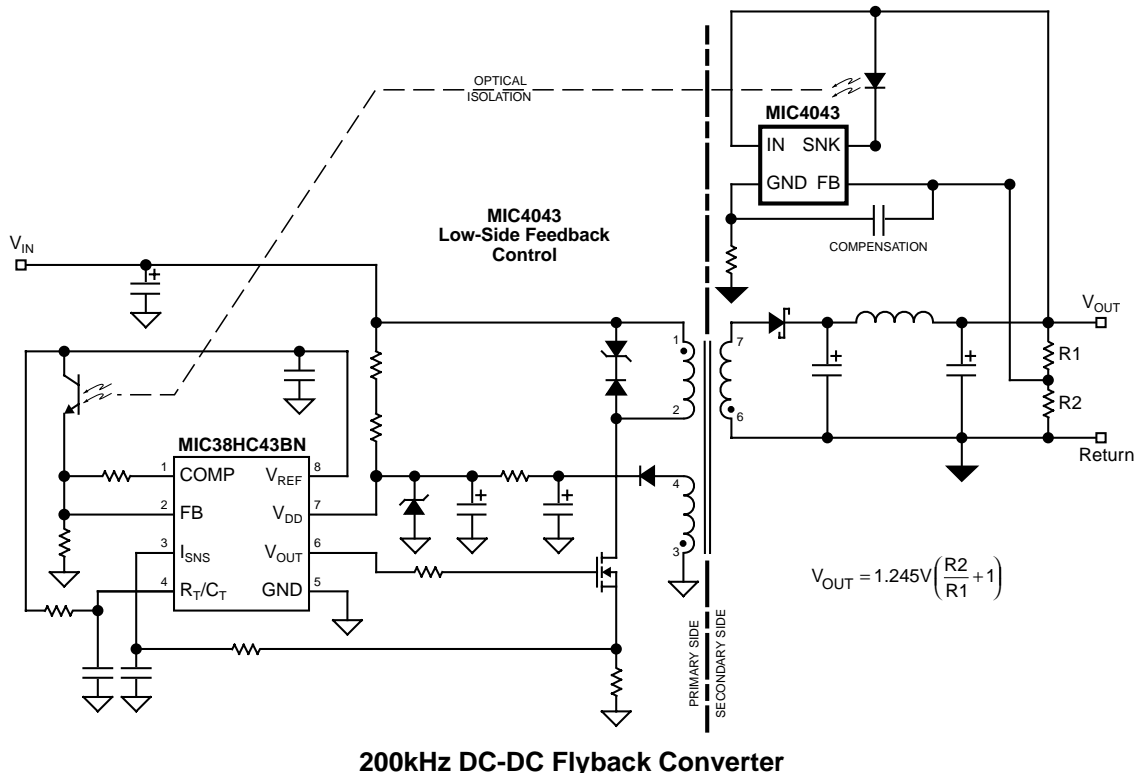

Ordering Information

Part Number	Marking	Voltage	Tolerance	Configuration	Temperature Range	Package	Lead-Finish
MIC4043BM4	RB1D	1.245V	1%	Open Collector	-40°C to +85°C	SOT-143	Leaded
MIC4043YM4	RB1D	1.245V	1%	Open Collector	-40°C to +85°C	SOT-143	Pb-Free

Pin Configuration

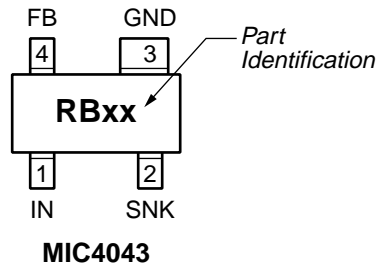

Pin Description

Pin Number	Pin Name	Pin Function
1	IN	Input: Supply voltage input.
2	SNK	Sink (Output): NPN open collector output.
3	GND	Ground
4	FB	Feedback (Input): Feedback input from external voltage-divider network.

Absolute Maximum Ratings (Note 1)

Input Voltage (V_{IN})+15V
Output Voltage (V_{SNK})+15V
Storage Temperature (T_S)-65°C to +150°C
ESD Rating, Note 3	
human body model2kV
machine model200V

Operating Ratings (Note 2)

Input Voltage (V_{IN})+10V
Output Voltage (V_{SNK})+10V
Maximum Output Current (I_{SNK})15mA
Temperature Range (T_A)-40°C to +85°C

Electrical Characteristics

$T_A = 25^\circ\text{C}$, **bold** values indicate $-40^\circ\text{C} \leq T_A \leq +85^\circ\text{C}$; unless noted

Parameter	Condition	Min	Typ	Max	Units
Reference Voltage, Note 4			1.245		V
Reference Voltage Tolerance				± 1 ± 2	% %
Supply Current	$I_{\text{SNK}} = 0\text{mA}$		35	65 70	μA μA
Transconductance $\Delta I_{\text{SNK}}/\Delta V_{\text{IN}}$	$1\text{mA} < I_{\text{SNK}} < 15\text{mA}$	3.5 2	150		S S
Output Transistor Saturation Voltage	$I_{\text{SNK}} = 15\text{mA}$		160	250 400	mV mV
Output Leakage	$V_{\text{SNK}} = 5\text{V}$, output transistor off			0.5 1	μA μA

- Note 1.** Exceeding the absolute maximum rating may damage the device.
- Note 2.** The device is not guaranteed to function outside its operating rating.
- Note 3.** Devices are ESD sensitive. Handling precautions recommended. Human body model, 1.5k in series with 100pF. Machine model, 200pF.
- Note 4.** Reference voltage is not referenced to ground. The reference is between pins IN and FB.

Test Circuits

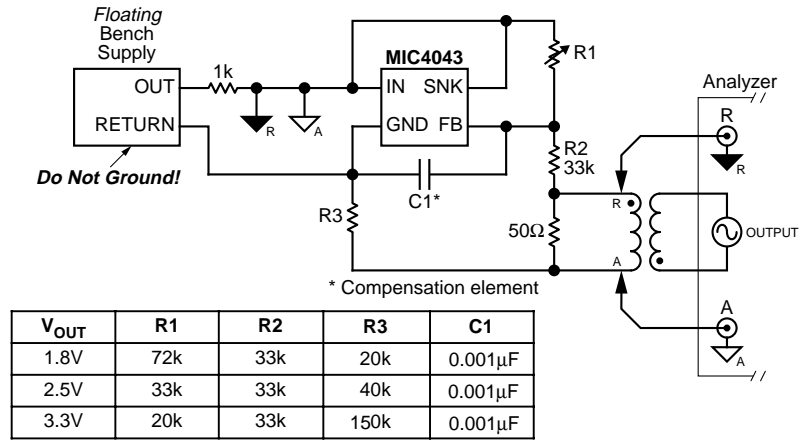

Test Circuit 1. Compensation (Bode Plot) Circuit

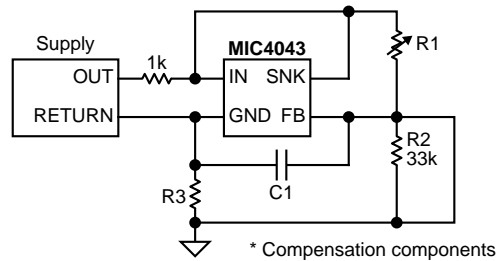

Test Circuit 2. Transient Response Circuit

Transient Response 1a.
1.8V Output

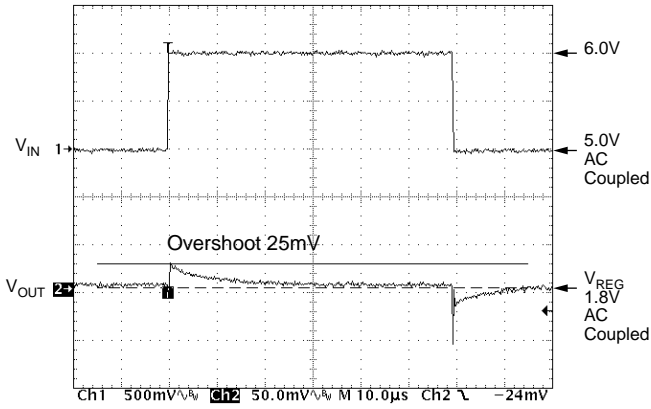

Turn On Transient Response 1b.
1.8V Output

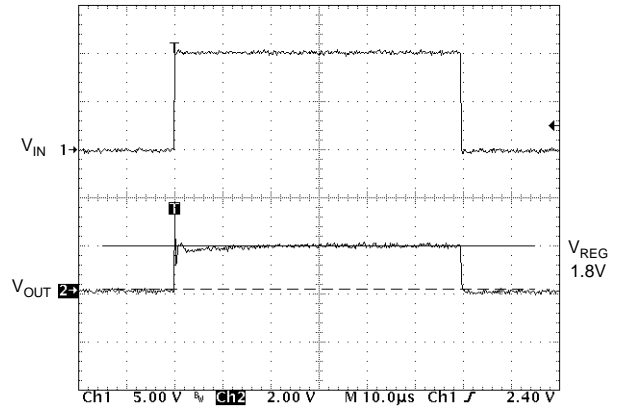

Transient Response 2a.
1.8V Output

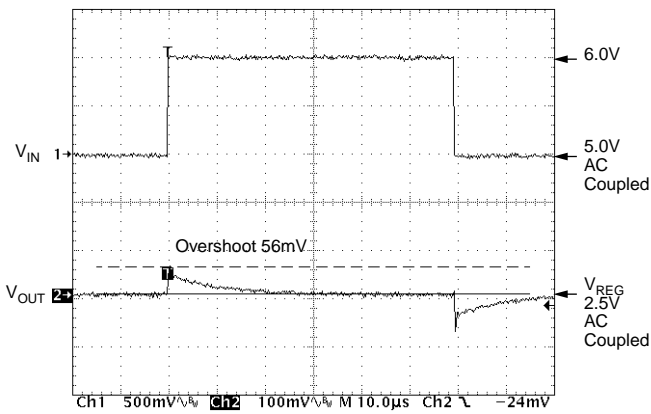

Turn On Transient Response 2b.
1.8V Output

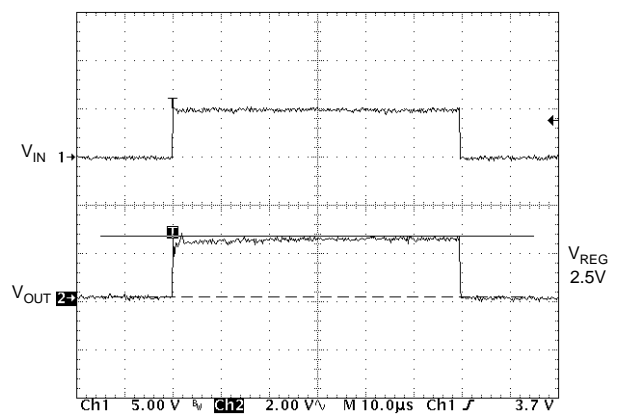

Transient Response 2a.
1.8V Output

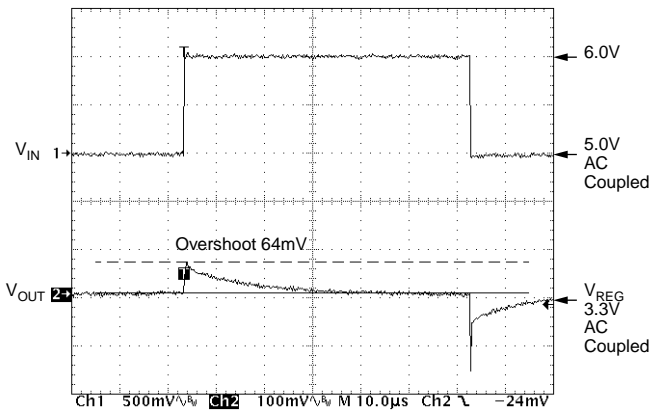

Turn On Transient Response 3b.
1.8V Output

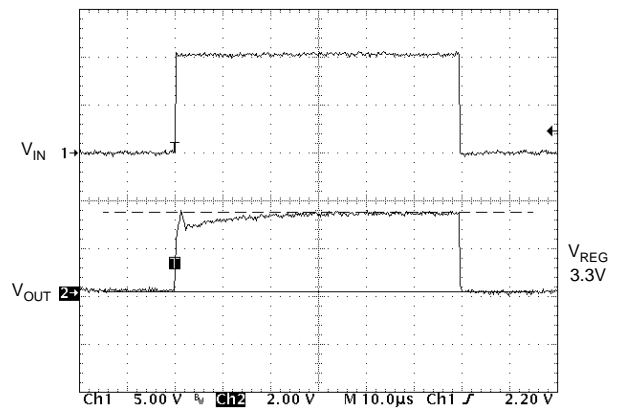

Functional Diagram

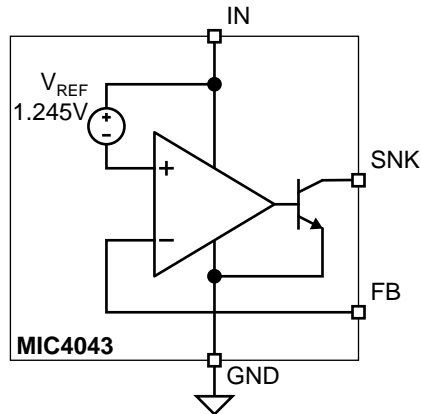

Functional Description

The MIC4043 combines a G_m amplifier, precision 1.245V reference, and a pass transistor in a single package.

The operation of the MIC4043 is similar to conventional shunt regulators such as the industry standard '431. In a closed loop system, the MIC4043 maintains the desired feedback voltage at the FB pin by sinking current onto the SNK pin proportional to the error voltage at the FB pin. The ratio of sink current to error voltage is the transconductance of the device.

Reference

The MIC4043 uses a **high-side reference**. External voltage dividers providing feedback to the MIC4043 will be **inverted** when compared to those used with '431-equivalent devices.

Behavior

The external feedback voltage is compared to the internal high-side 1.245V reference.

If the feedback voltage, V_{FB} , is less than $V_{IN} - V_{REF}$, the amplifier provides no drive to the sink transistor. If the feedback voltage is greater than $V_{IN} - V_{REF}$, the amplifier drives the pass transistor which sinks current to ground.

Applications Information

Replacement of '431-Type Devices

Since the MIC4043 uses a high-side reference, ***external voltage dividers providing the feedback voltage will be inverted when compared to those used with '431-equivalent devices.***

The industry-standard '431 is also typically used in series with an opto-isolator LED. This configuration has a voltage drop of at least 2.5V for the '431 plus 1.4V for the LED (3.9V). More recent lower-voltage shunt regulators require at least 1.25V of headroom in addition to the 1.4V for the opto isolator, for a total of 2.65V.

The MIC4043 removes the need to place the shunt reference in parallel with the opto-isolator. The MIC4043 combines a 1.245V reference in conjunction with an error amplifier that drives an NPN output transistor. The NPN transistor is connected in series with the opto-isolator and regulates the drive current in the opto-isolator. Unlike conventional shunt regulators, the MIC4043 does not have to connect the shunt reference in series with the opto-isolator. Only the NPN output stage is in series with the opto-isolator, so the voltage drop is just the saturation voltage or one transistor, typically 160mV at full load

Compensation

The noninverting side of the error amplifier is connected to the high-side reference; the reference is connected to the IN pin. The inverting side of the error amplifier is brought out to the FB pin. For some applications, no compensation is needed, but for most, some resistor capacitor network is necessary between the FB pin and GND pin. The value of the feedback capacitance is application specific, but for most applications 100pF to 3000pF is all that is needed. Changing the feedback capacitor changes the loop response; that is, phase and gain margin. An empirical way to check overall system loop

response, if a network analyzer is not available, is to step load the output of the systems from 10% to 100% of nominal load. The resultant small signal response at the output of the systems will provide an idea of which direction to go based on the overshoot and settling time of V_{OUT} .

Voltage Detector

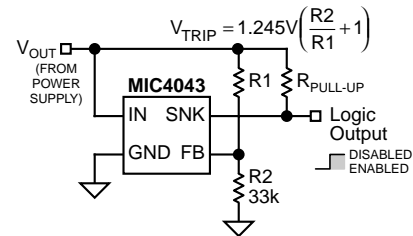

Figure 1. Voltage Detector

Figure 1 shows a simple voltage threshold detector with a logic output.

High-Current Regulator

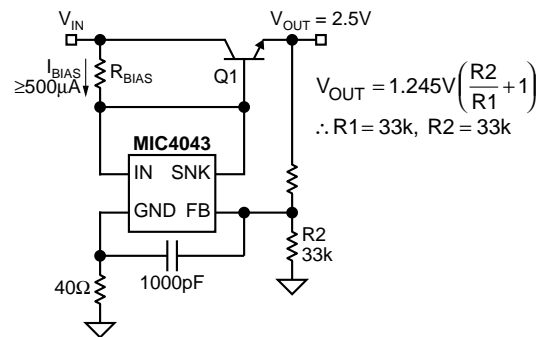

Figure 2. High-Current Regulator

For the high-current regulator shown in Figure 2, headroom is equal to the saturation voltage of Q1 plus the saturation voltage of the MIC4043 ($V_{SAT(min)} = 200mV$).

Off-Line 1.8V/2A Power Supply

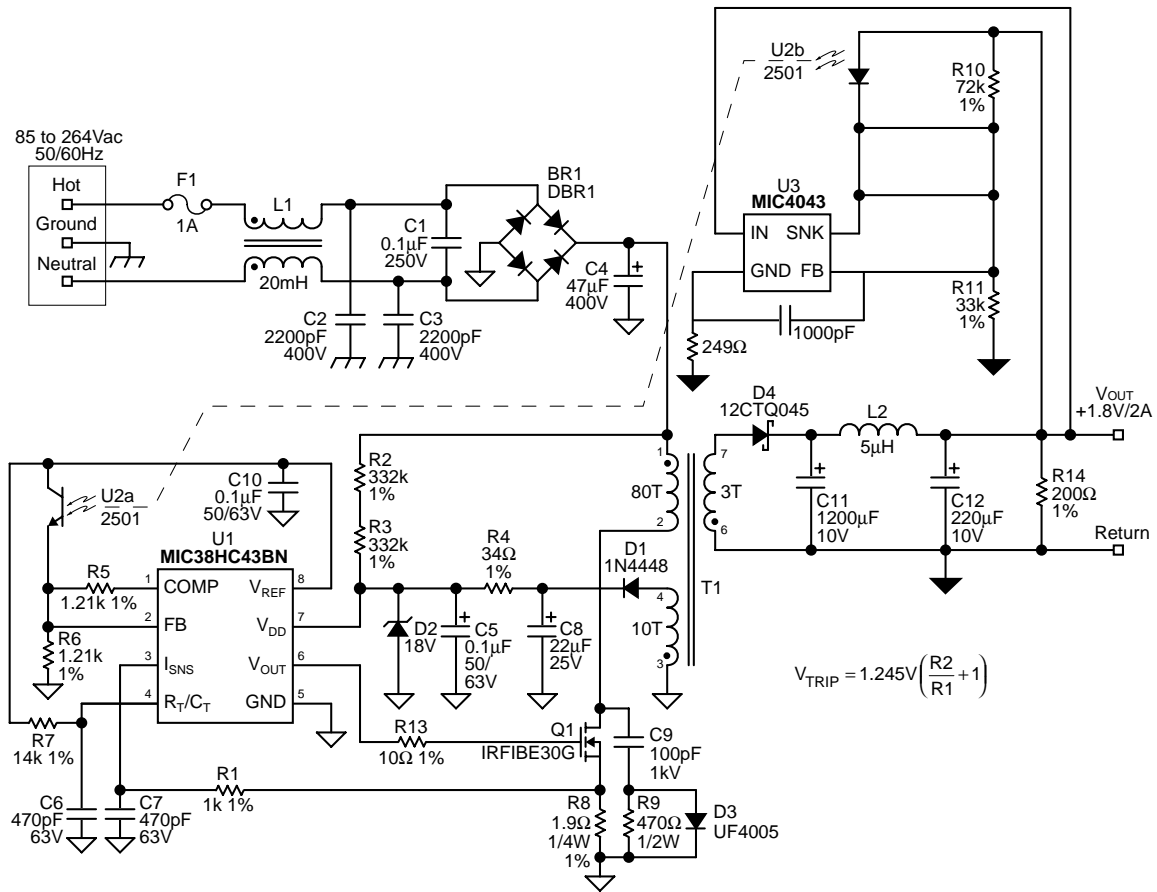

Figure 3. Off-Line 1.8V/2A Power Supply

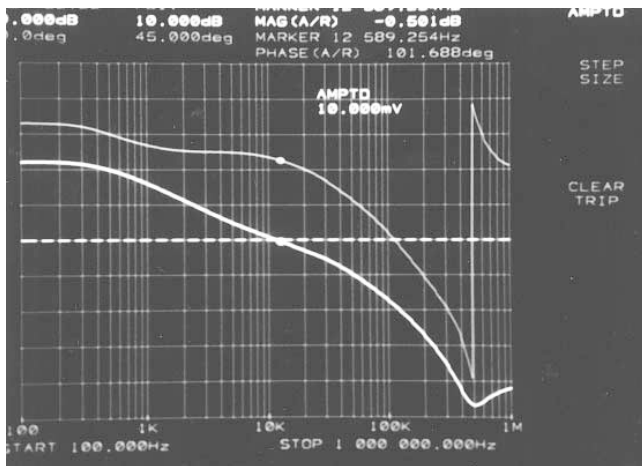

Figure 3a. 1.8V/1A Bode Plot
(θ margin = 102°)

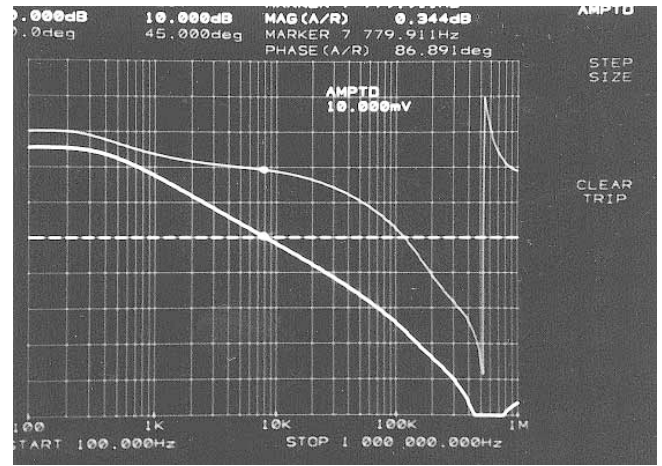

Figure 3b. 1.8V/2A Bode Plot
(θ margin = 87°)

Off-Line 2.5V/2A Power Supply

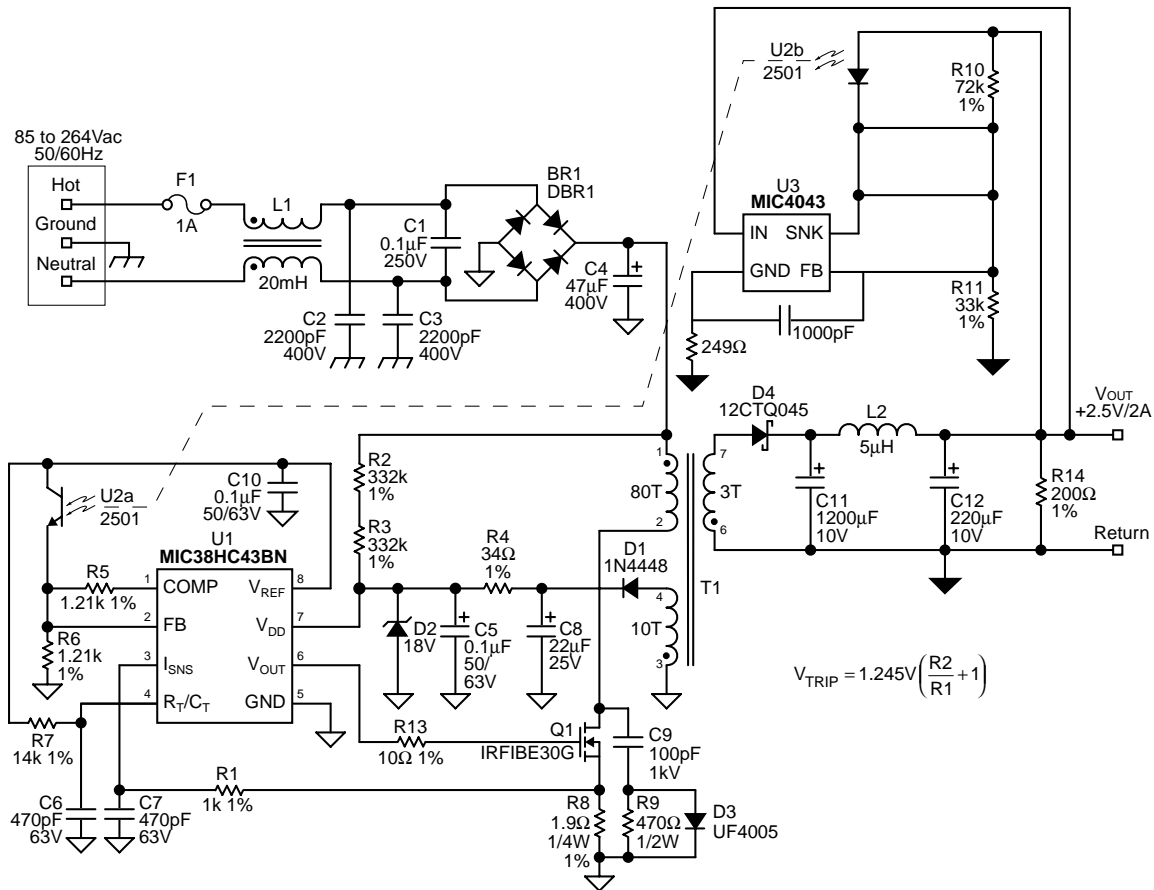

Figure 4. Off-Line 2.5V/2A Power Supply

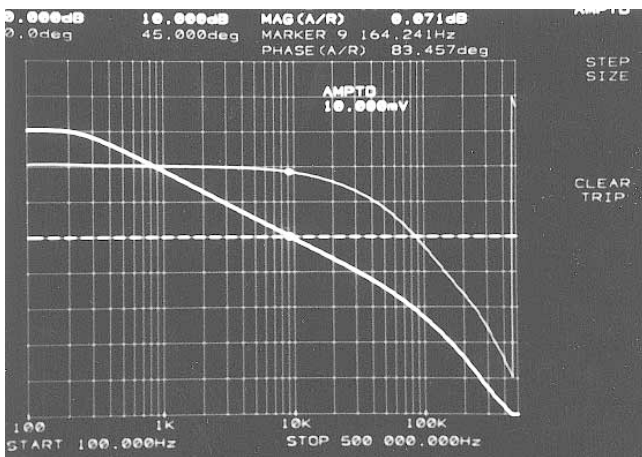

Figure 4a. 2.5V/1A Bode Plot
(θ margin = 83°)

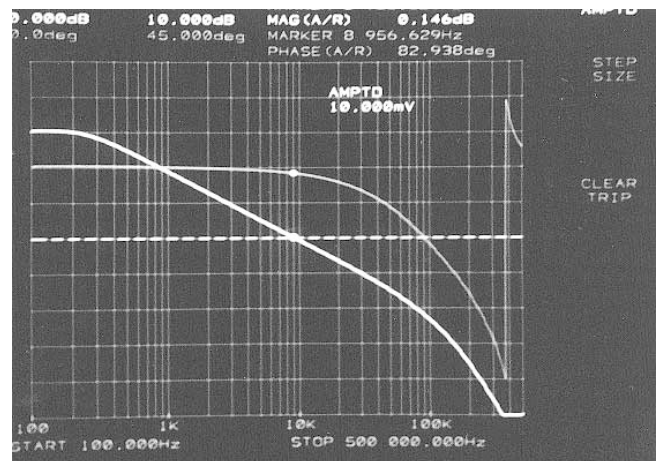

Figure 4b. 2.5V/2A Bode Plot
(θ margin = 83°)

Off-Line 3.3V/2A Power Supply

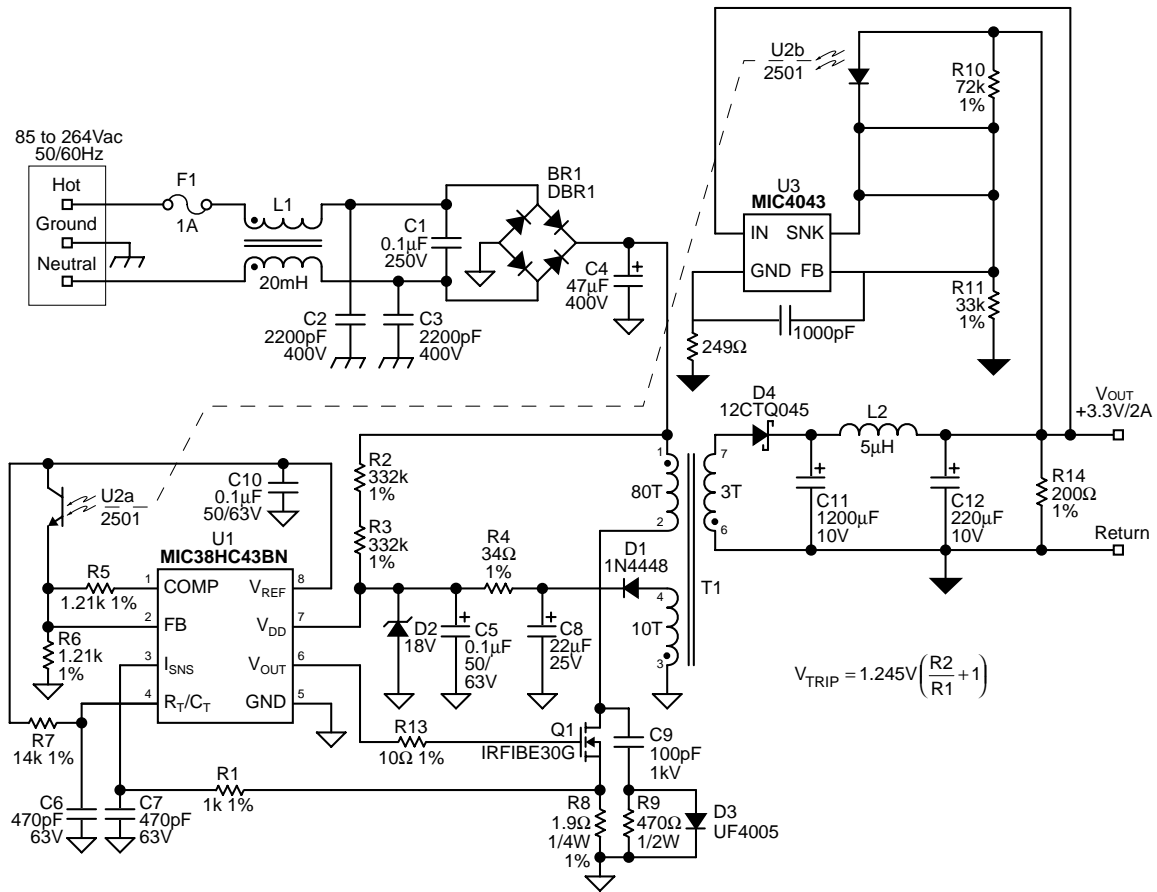

Figure 5. Off-Line 3.3V/2A Power Supply

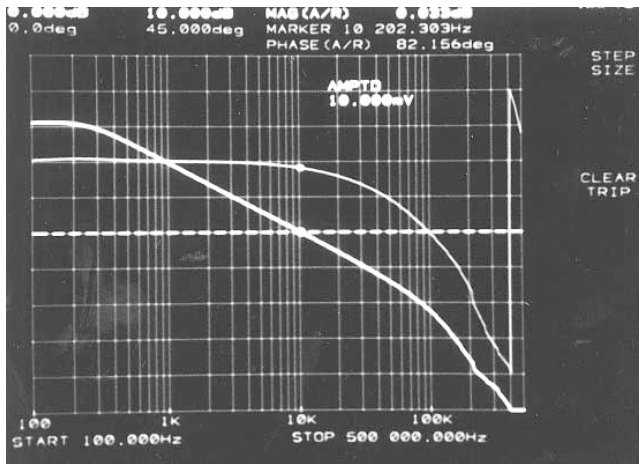

Figure 5a. 3.3V/1A Bode Plot
(θ margin = 82°)

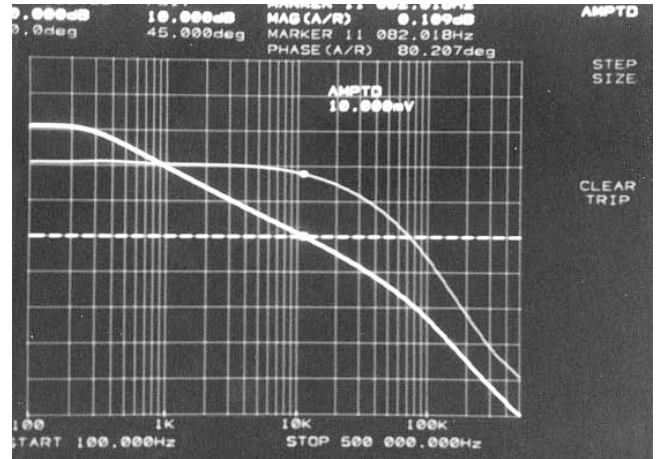
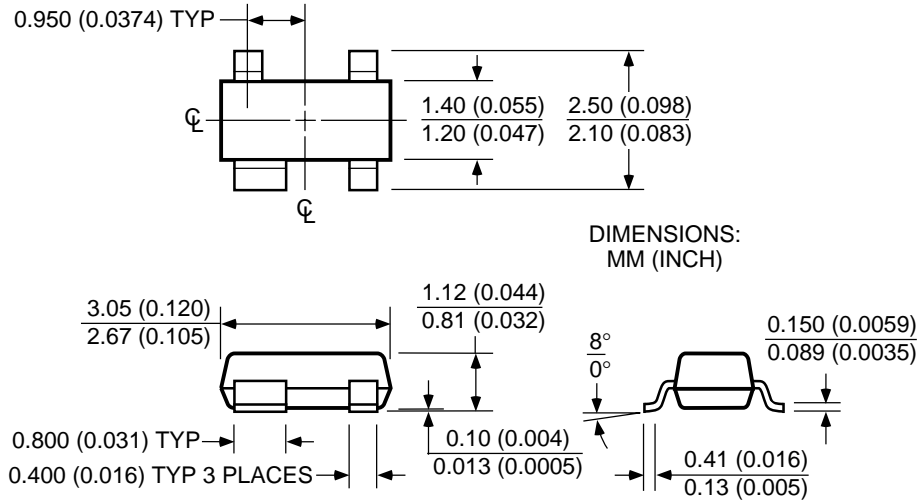

Figure 5b. 3.3V/2A Bode Plot
(θ margin = 80°)

Package Information



SOT-143 (M4)

MICREL INC. 1849 FORTUNE DRIVE SAN JOSE, CA 95131 USA

TEL + 1 (408) 944-0800 FAX + 1 (408) 944-0970 WEB <http://www.micrel.com>

This information is believed to be accurate and reliable, however no responsibility is assumed by Micrel for its use nor for any infringement of patents or other rights of third parties resulting from its use. No license is granted by implication or otherwise under any patent or patent right of Micrel Inc.

© 2000 Micrel Incorporated

Mouser Electronics

Authorized Distributor

Click to View Pricing, Inventory, Delivery & Lifecycle Information:

[Micrel:](#)

[MIC4043YM4 TR](#)