

Data Sheet

Rev. 1.64 / July 2014

ZSC31014

RBic_iLite™ Digital Output Sensor Signal Conditioner



Multi-Market Sensing Platforms



Precise and Deliberate

ZSC31014

RBic_{Lite}TM Digital Output Sensor Signal Conditioner

ZMDI[®]

The Analog Mixed Signal Company



Brief Description

The ZSC31014 is a CMOS integrated circuit for highly accurate amplification and analog-to-digital conversion of differential and half-bridge input signals. The ZSC31014 can compensate the measured signal for offset, 1st and 2nd order span, and 1st and 2nd order temperature (Tco and Tcg). It is well suited for sensor-specific correction of bridge sensors. Digital compensation of signal offset, sensitivity, temperature drift, and non-linearity is accomplished via an internal digital signal processor running a correction algorithm with calibration coefficients stored in a non-volatile EEPROM.

The ZSC31014 is adjustable to nearly all piezo-resistive bridge sensors. Measured and corrected bridge values are provided at digital output pins, which can be configured as I²CTM* or SPI. The digital I²CTM interface can be used for a simple PC-controlled calibration procedure to program calibration coefficients into an on-chip EEPROM. The calibrated ZSC31014 and a specific sensor are mated digitally: fast, precise, and without the cost overhead associated with trimming by external devices or laser trimming.

The ZSC31014's integrated diagnostics functions are well suited for safety-critical applications.

Features

- High accuracy ($\pm 0.1\%$ FSO @ -25 to +85°C; $\pm 0.25\%$ FSO @ -40 to +125°C)
- 2nd order charge-balancing analog-to-digital converter provides low noise, 14-bit data at sample rates exceeding 2kHz
- Fast power-up to data output response: 3ms at 4MHz
- Digital compensation of sensor offset, sensitivity, temperature drift, and non-linearity
- Eight programmable analog gain settings combine with a digital gain term; accommodates bridges with spans $< 1\text{mV/V}$ and high offset
- Internal temperature compensation for sensor correction and for corrected temperature output
- 48-bit customer ID field for module traceability

* I²CTM is a trademark of NXP.

Benefits

- Simple PC-controlled configuration and single-pass digital calibration via I²CTM interface – quick and precise; SPI option for measurement mode
- Eliminates need for external trimming components
- On-chip diagnostic features add safety to the application (e.g., EEPROM signature, bridge connection checks, bridge short detection).
- Low-power Sleep Mode lengthens battery life
- Enables multiple sensor networks

Available Support

- Evaluation Kit
- Application Notes
- Mass Calibration Solution

Physical Characteristics

- Wide supply voltage capability: 2.7V to 5.5V
- Current consumption as low as 70 μA depending on programmed sample rate
- Low-power Sleep Mode ($< 2\mu\text{A}$ @ 25°C)
- Operation temperature: -40°C to +125°C
- Small SOP8 package

ZSC31014 Application: I²CTM Interface, Low-Power Bsink Option, Internal Temperature Correction

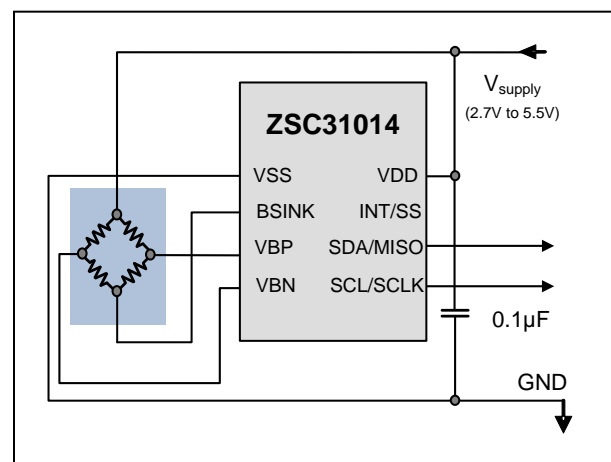

For more information, contact ZMDI via SSC@zmdi.com.

ZSC31014

RBiCiLite™ Digital Output Sensor Signal Conditioner



The Analog Mixed Signal Company



ZSC31014 Block Diagram

Applications:

Industrial: building automation, data loggers, pressure meters, leak detection monitoring

Medical: infusion pumps, blood pressure meters, air mattresses, apnea monitors

White Goods / Appliances: fluid level, refrigerant

Consumer: body monitors, portable monitors, desktop weather stations, bathroom scales, toys/games

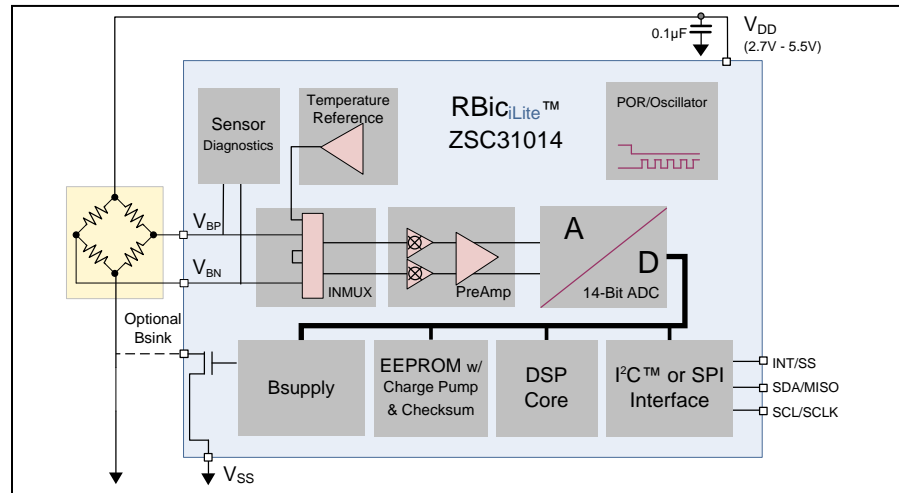

Application: Half-Bridge Voltage Measurement

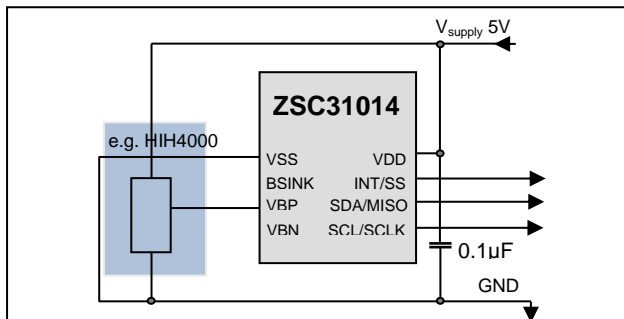

Application: Generic Differential A2D Converter

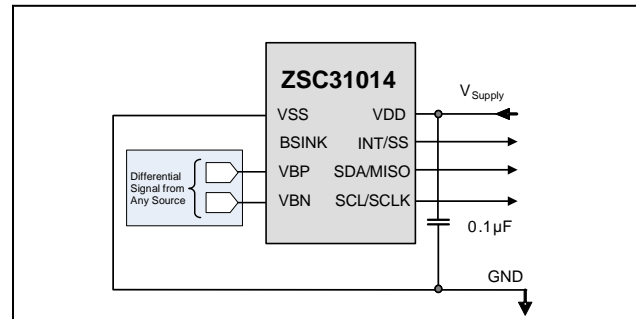

Ordering Examples (Refer to section 10 in the data sheet for additional options.)

Sales Code	Description	Package
ZSC31014EAB	ZSC31014 Die — Temperature range: -40°C to +125°C	Unsawn on Wafer
ZSC31014EAC	ZSC31014 Die — Temperature range: -40°C to +125°C	Sawn on Wafer Frame
ZSC31014EAG1	ZSC31014 SOP8 (150 mil) — Temperature range: -40° to +125°C	Tube: add "-T" to sales code / Reel: add "-R"
ZSC31014KIT	ZSC31014 SSC Evaluation Kit: Communication Board, SSC Board, Sensor Replacement Board, USB Cable, 5 IC Samples (software can downloaded on www.zmdi.com/zsc31014)	Kit

Sales and Further Information		www.zmdi.com	SSC@zmdi.com
Zentrum Mikroelektronik Dresden AG Global Headquarters Grenzstrasse 28 01109 Dresden, Germany Central Office: Phone: +49.351.8822.306 Fax: +49.351.8822.337	ZMD America, Inc. 1525 McCarthy Blvd., #212 Milpitas, CA 95035-7453 USA USA Phone 1.855.275.9634 Phone +1.408.883.6310 Fax +1.408.883.6358	Zentrum Mikroelektronik Dresden AG, Japan Office 2nd Floor, Shinbashi Tokyu Bldg. 4-21-3, Shinbashi, Minato-ku Tokyo, 105-0004 Japan Phone +81.3.6895.7410 Fax +81.3.6895.7301	ZMD FAR EAST, Ltd. 3F, No. 51, Sec. 2, Keelung Road 11052 Taipei Taiwan Phone +886.2.2377.8189 Fax +886.2.2377.8199
Zentrum Mikroelektronik Dresden AG, Korea Office U-space 1 Building 11th Floor, Unit JA-1102 670 Sampyeong-dong Bundang-gu, Seongnam-si Gyeonggi-do, 463-400 Korea Phone +82.31.950.7679 Fax +82.504.841.3026	European Technical Support Phone +49.351.8822.7.772 Fax +49.351.8822.87.772		
European Sales (Stuttgart) Phone +49.711.674517.55 Fax +49.711.674517.87955	DISCLAIMER: This information applies to a product under development. Its characteristics and specifications are subject to change without notice. Zentrum Mikroelektronik Dresden AG (ZMD AG) assumes no obligation regarding future manufacture unless otherwise agreed to in writing. The information furnished hereby is believed to be true and accurate. However, under no circumstances shall ZMD AG be liable to any customer, licensee, or any other third party for any special, indirect, incidental, or consequential damages of any kind or nature whatsoever arising out of or in any way related to the furnishing, performance, or use of this technical data. ZMD AG hereby expressly disclaims any liability of ZMD AG to any customer, licensee or any other third party, and any such customer, licensee and any other third party hereby waives any liability of ZMD AG for any damages in connection with or arising out of the furnishing, performance or use of this technical data, whether based on contract, warranty, tort (including negligence), strict liability, or otherwise.		

ZSC31014

RBic_{Lite}TM Digital Output Sensor Signal Conditioner

ZMDI[®]

The Analog Mixed Signal Company



Contents

1	IC Characteristics	8
1.1.	Absolute Maximum Ratings	8
1.2.	Recommended Operating Conditions	8
1.3.	Electrical Parameters	9
1.4.	Current Consumption	11
1.4.1.	Update Mode Current Consumption	11
1.4.2.	Sleep Mode Current Consumption	12
1.5.	Analog Input versus Output Resolution	12
2	Circuit Description	15
2.1.	Signal Flow and Block Diagram	15
2.2.	Analog Front End	16
2.2.1.	Preamplifier (PreAmp)	16
2.2.2.	Analog-to-Digital Converter	17
2.2.3.	Temperature Measurement	20
2.2.4.	Bridge Supply (Bsink)	21
2.2.5.	Analog Front-End Configuration	21
2.3.	Digital Signal Processor	22
2.3.1.	Digital Core	22
2.3.2.	Normal Operation Mode	22
2.3.3.	EEPROM	22
2.3.4.	Digital Interface – I ² C TM	23
2.3.5.	Digital Interface – SPI	25
2.3.6.	Clock Generator / Power-On Reset (CLKPOR)	26
2.4.	Diagnostic Features	26
2.4.1.	EEPROM Integrity	27
2.4.2.	Sensor Connection Check	27
2.4.3.	Sensor Short Check	27
3	Functional Description	28
3.1.	General Working Mode	28
3.1.1.	Update Mode	30

ZSC31014

RBic_{Lite}TM Digital Output Sensor Signal Conditioner

ZMDI[®]

The Analog Mixed Signal Company



3.1.2.	Sleep Mode	32
3.2.	ZSC31014 Read Operations with I ² C TM	35
3.2.1.	I ² C TM Read_MR (Measurement Request)	36
3.2.2.	I ² C TM Read_DF (Data Fetch)	36
3.3.	SPI Read Operations	36
3.3.1.	SPI Read_MR (Measurement Request)	36
3.3.2.	SPI Read_DF (Data Fetch)	37
3.4.	I ² C TM Write Operations	38
3.4.1.	I ² C TM Write_MR (Measurement Request)	38
3.4.2.	Command Mode I ² C TM Write Operations	39
3.5.	Command/Data Pair Encoding in Command Mode	39
3.6.	EEPROM Bits	40
3.7.	Calibration Sequence	46
3.8.	Calibration Math	47
3.8.1.	Bridge Signal Compensation	48
3.8.2.	Temperature Signal Compensation	49
3.8.3.	Limits Imposed on Coefficient Ranges	49
3.8.4.	Interpretation of Binary Numbers for Correction Coefficients	50
4	Application Circuit Examples	52
4.1.	I ² C TM Interface – Bridge using Low Power Bsink Option	52
4.2.	Generic Differential A2D Converter	53
4.3.	Half-Bridge Measurement	54
5	ESD/Latch-Up-Protection	55
6	Pin Configuration and Package	55
7	Test	56
8	Reliability	56
9	Customization	57
10	Ordering Codes	57
11	Related Documents	57
12	Definitions of Acronyms	58
13	Document Revision History	58

ZSC31014

RBic_{Lite}TM Digital Output Sensor Signal Conditioner

ZMDI[®]

The Analog Mixed Signal Company



List of Figures

Figure 1.1	Update Mode Current Consumption with Minimum Update Rate	11
Figure 1.2	Update Mode Current Consumption with Maximum Update Rate	11
Figure 1.3	Sleep Mode Current Consumption	12
Figure 2.1	ZSC31014 Block Diagram	15
Figure 2.2	Functional Diagram of the ADC	19
Figure 2.3	Format for AFE Configuration Registers B_Config and T_Config	21
Figure 2.4	I ² C TM Timing Diagram	24
Figure 2.5	SPI Bus Data Output Timing	25
Figure 3.1	General Working Mode	29
Figure 3.2	Power-Up Sequence and Timing for Update Mode with EEPROM Locked	30
Figure 3.3	Measurement Sequence in Update Mode	32
Figure 3.4	Power-on Sequence in Sleep Mode for I ² C TM or SPI Read_MR (Typical Timing Values)	34
Figure 3.5	Sequence during Sleep Mode Using an I ² C TM Write_MR to Wake Up (Typical Timing Values ^{**})	34
Figure 3.6	I ² C TM Measurement Packet Reads	35
Figure 3.7	SPI Read_MR	36
Figure 3.8	SPI Output Packet with Falling Edge SPI_Polarity	37
Figure 3.9	I ² C TM Measurement Packet Writes	38
Figure 4.1	Example 1 Circuit Diagram: Bsink Option and Internal Temperature Correction and I ² C TM Output	52
Figure 4.2	Example 2 Circuit Diagram: Generic Differential A2D Converter	53
Figure 4.3	Half-Bridge Voltage Measurement with Internal Temperature Correction	54
Figure 6.1	ZSC31014 Pin-Out Diagram	56

ZSC31014

RBic_{Lite}TM Digital Output Sensor Signal Conditioner

ZMDI[®]

The Analog Mixed Signal Company



List of Tables

Table 1.1	ZSC31014 Maximum Ratings.....	8
Table 1.2	ZSC31014 Recommended Operating Conditions	8
Table 1.3	ZSC31014 Electrical Parameters	9
Table 1.4	Minimum Guaranteed Resolution for the Analog Gain Settings.....	13
Table 2.1	Preamplifier Gain Control Signals	16
Table 2.2	Gain Polarity Control Signal.....	16
Table 2.3	Disable Nulling Control Signal	17
Table 2.4	A2D_Offset Signals	18
Table 2.5	Parameters of the Internal Temperature Sensor Bridge	20
Table 2.6	Supported I ² C TM Bit Rates	23
Table 2.7	I ² C TM Parameters.....	24
Table 2.8	SPI Parameters.....	25
Table 2.9	2 MSB of Data Packet Encoding	26
Table 3.1	Command Types	28
Table 3.2	Update Rate Settings (Normal Integration Mode: 9 Coarse + 5 Fine)	31
Table 3.3	Update Rate Settings (Long Integration Mode: 10 Coarse + 5 Fine)	31
Table 3.4	Sleep Mode Response Times (Normal Integration Mode: 9 Coarse + 5 Fine)	33
Table 3.5	Sleep Mode Response Times (Long Integration Mode: 10 Coarse + 5 Fine)	33
Table 3.6	Command List and Encodings.....	39
Table 3.7	EEPROM Word/Bit Assignments.....	40
Table 3.8	Restrictions on Coefficient Ranges.....	49
Table 3.9	Gain_B Weightings	50
Table 3.10	Offset_B Weightings	51
Table 4.1	Register Settings—Example 1.....	52
Table 4.2	Register Settings—Example 2.....	53
Table 4.3	Register Settings—Example 3.....	54
Table 6.1	Storage and Soldering Conditions for the SOP-8 Package.....	55
Table 6.2	ZSC31014 Pin Assignments.....	56

ZSC31014

RBic_{Lite}TM Digital Output Sensor Signal Conditioner

ZMDI[®]

The Analog Mixed Signal Company



1 IC Characteristics

1.1. Absolute Maximum Ratings

Table 1.1 ZSC31014 Maximum Ratings

PARAMETER	SYMBOL	MIN	TYP	MAX	UNITS
Analog Supply Voltage	V _{DD}	-0.3		6.0	V
Voltages at Digital and Analog I/O – In Pin	V _{INA}	-0.3		V _{DD} +0.3	V
Voltages at Digital and Analog I/O – Out Pin	V _{OUTA}	-0.3		V _{DD} +0.3	V
Storage Temperature Range (≥10 hours)	T _{STOR}	-50		150	°C
Storage Temperature Range (<10 hours)	T _{STOR<10h}	-50		170	°C

Note: Also see Table 6.1 regarding soldering temperature and storage conditions for the SOP-8 package.

1.2. Recommended Operating Conditions

Table 1.2 ZSC31014 Recommended Operating Conditions

PARAMETER	SYMBOL	MIN	TYP	MAX	UNITS
Analog Supply Voltage to Gnd	V _{DD}	2.7		5.5	V
Ambient Temperature Range ¹⁾	T _{AMB}	-40		125	°C
CM Voltage Range ²⁾	V _{IN}	1		V _{DD} -1.2	V
External Capacitance between V _{DD} and Gnd	C _{VDD}	100	220	470	nF
Pull-up on SDA and SCL	R _{PU}	1			kΩ
Bridge Resistance	R _{BR}	0.2		100	kΩ

1) If buying die, designers should use caution not to exceed maximum junction temperature by proper package selection.

2) Both BP and BN input voltage must be within the specified range. In Half-Bridge Mode, this requirement applies only to the BP input (gain 1.5 and 3). In this mode, BN is connected internally to V_{DD}/2.

ZSC31014

RBiC_{Lite}TM Digital Output Sensor Signal Conditioner



The Analog Mixed Signal Company



1.3. Electrical Parameters

Note: See important notes at the end of the table.

Table 1.3 ZSC31014 Electrical Parameters

PARAMETER	SYMBOL	CONDITIONS	MIN	TYP	MAX	UNITS
SUPPLY						
Update Mode Supply Current (See section 1.4.1)	I _{DD}	At minimum update rate (1MHz clock)	70	120		μA
		At maximum update rate (4MHz clock). See section 3.1.1 for more details. Minimum current is achieved at slow update rates.		2000	2500	
Sleep Mode Supply Current (See section 1.4.2)	I _{sndby}	-40°C to +85°C		0.5	5	μA
		-40°C to +125°C		0.5	32	μA
Power-On-Reset Level	POR		1.8		2.5	V
ANALOG FRONT END (AFE)						
Leakage Current Pins VBP, VBN	I _{IN_LEAK}	Sensor connection and short checks must be disabled.			±20	nA
EEPROM						
Number of Erase/Write Cycles	n _{WRI_EEP}	At 85°C			100k	Cycles
Data Retention	t _{WRI_EEP}	At 100°C			10	Years
ANALOG-TO-DIGITAL CONVERTER (ADC)						
Resolution	r _{ADC}			14		Bits
Temperature Resolution					11	Bits
Integral Nonlinearity (INL) ¹⁾	INL _{ADC}	Based on ideal slope	-4		+4	LSB
Differential Nonlinearity ²⁾ (DNL)	DNL _{ADC}		-1		+1	LSB
I²CTM INTERFACE & SPI INTERFACE						
Input Low Level	V _{IN_low}	SDA/MISO and SCL/SCLK	0		0.2	V _{DD}
Input High Level	V _{IN_high}	SDA/MISO and SCL/SCLK	0.8		1	V _{DD}
Input leakage to V _{SS}	I _{il}	SDA/MISO, SCL/SCLK, and INT/SS with output disabled	-1.0		+1.0	μA
Input leakage to V _{DD}	I _{ih}	SDA/MISO and INT/SS with output disabled	-1.0		+1.0	μA
	I _{ih_PU}	SCL/SCLK with weak pull-up		-1.2	-5	μA
Output Sourcing Current	I _{OH_SDA/MISO}	SDA/MISO @ V _{OH} = V _{DD} -0.2V	-1.9	-3.1	-4.8	mA
	I _{OH_INT/SS}	INT/SS @ V _{OH} = V _{DD} -0.2V	-0.63	-1.2	-1.9	mA

ZSC31014

RBiC_{iLite}TM Digital Output Sensor Signal Conditioner



The Analog Mixed Signal Company



PARAMETER	SYMBOL	CONDITIONS	MIN	TYP	MAX	UNITS
Output Sink Current	I _{OL_SDA/MISO}	SDA/MISO @V _{OI} = 0.2v	2.3	3.9	6.2	mA
	I _{OL_INT/SS}	INT/SS @V _{OI} = 0.2v	0.85	1.7	3.0	mA
Load Capacitance at SDA	C _{SDA}	@ 400kHz			200	pF
Pull-up Resistor	R _{I2C_PU}		500			Ω
Input Capacitance (each pin)	C _{I2C_IN}				10	pF
TOTAL SYSTEM						
Frequency Variation	f _{var}	All timing in the specification is subject to this variation.			±15	%
Start-Up-Time ^{3), 4), 5)} (Power-up to data ready)	t _{STA}	@ 4MHz(EEPROM locked)		2.8	3.2	ms
		@ 4MHz(EEPROM unlocked)		7.3	8.4	
		@ 1MHz(EEPROM locked)		6.0	6.9	
		@ 1MHz(EEPROM unlocked)		10.4	12	
Response Time ^{3), 4), 5)} (Time to data ready)	f _{meas}	@ 4MHz		0.5		ms
		@ 1MHz		1.6		
Overall Linearity Error ^{6), 7), 8)}	E _{LIND}	Within 5% to 95% of full-scale differential input.			±0.05	%FSO
Overall Ratiometricity Error ^{6), 9)}	RE _{out}	VDD ± 10%		±0.025	±0.1	%FSO
Overall Absolute Error ^{6), 10)}	AC _{out}	-25°C to +85°C, VDD ± 10%			±0.1	%FSO
		-40°C to +125°C, VDD ± 10%			±0.25	%FSO

- 1) Measured at highest PreAmp_Gain setting and -1/2 to 1/2 A2D_Offset setting.
- 2) Parameter not tested during production test but guaranteed by design.
- 3) In Update Rate Mode at fastest update rate.
- 4) See section 3.1 for more details.
- 5) Parameter indirectly tested during production test.
- 6) Bridge input to digital output.
- 7) For applications where Vdd <3.5V using A2D offsets 15/16, 7/8, 1/8, or 1/16, a slight overall linearity improvement of 0.015% FSO can be achieved.
- 8) FSO = percent full-scale output.
- 9) For high preamp gain (≥96) in conjunction with high clock frequency and normal integration (4MHz, longInt=0), the ratiometricity error can be ≤0.3%.
- 10) For applications requiring high preamp gain (≥96) in conjunction with a high clock frequency (4 MHz), calibration using three temperature points is required in order to achieve the specified "Overall Absolute Error." If calibration is performed using only two temperature points, the specified maximum error values must be increased by a factor of 3. A calibration using only one temperature point is not recommended for applications with high preamp gain (≥96) in conjunction with a high clock frequency (4 MHz).



1.4. Current Consumption

1.4.1. Update Mode Current Consumption

Figure 1.1 Update Mode Current Consumption with Minimum Update Rate

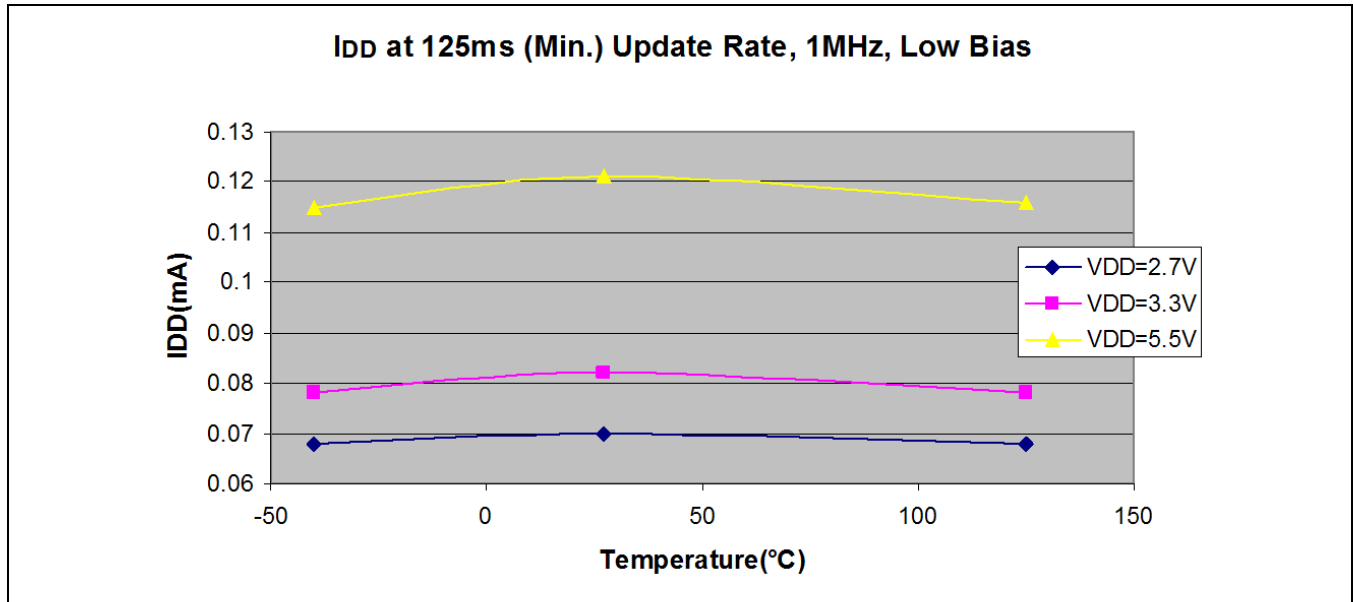
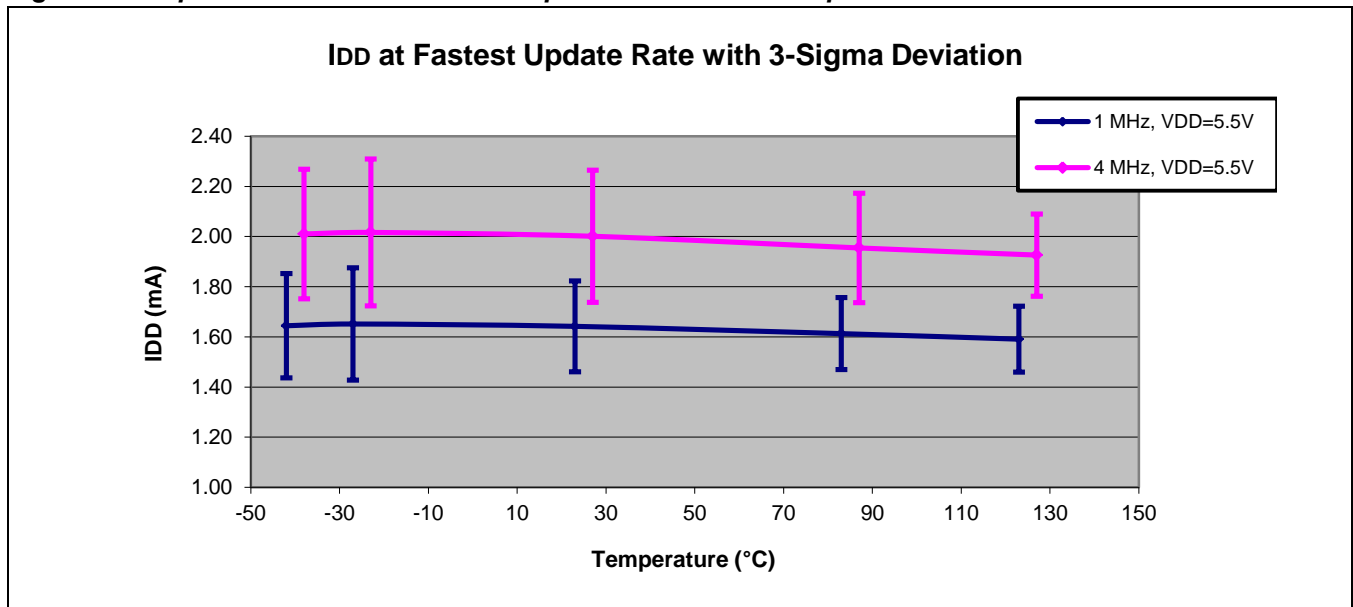

Figure 1.2 Update Mode Current Consumption with Maximum Update Rate



ZSC31014

RBiC_iLite™ Digital Output Sensor Signal Conditioner



The Analog Mixed Signal Company



1.4.2. Sleep Mode Current Consumption

Figure 1.3 Sleep Mode Current Consumption

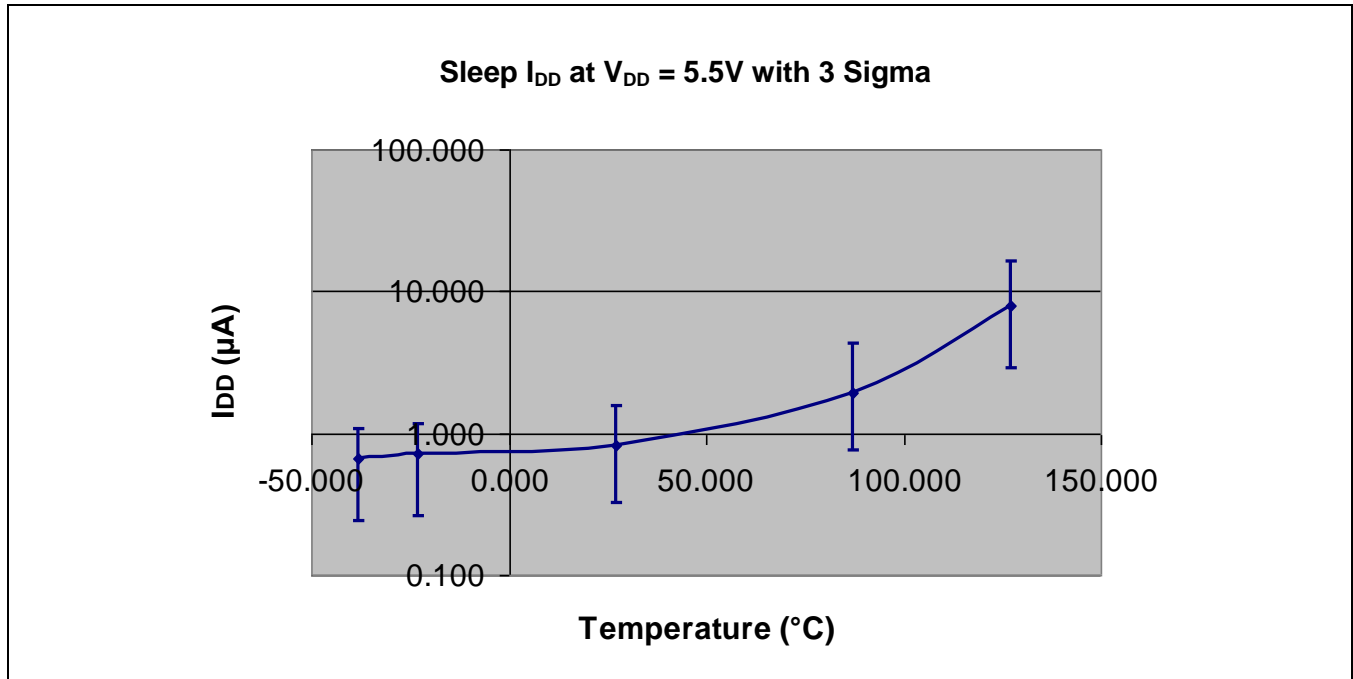

1.5. Analog Input versus Output Resolution

The ZSC31014 has a fully differential chopper-stabilized preamplifier with 8 programmable gain settings through a 14-bit analog-to-digital converter (ADC). The resolution of the output depends on the input span (bridge sensitivity) and the analog gain setting programmed. Analog gains available are 1.5, 3, 6, 12, 24, 48, 96, and 192.*

Table 1.4 gives the guaranteed minimum resolution for a given bridge sensitivity range for the eight analog gain settings. At higher analog gain settings, there will be higher output resolution, but the ability of the ASIC to handle large offsets decreases. This is expected because the offset is also amplified by the analog gain and can therefore saturate the ADC input.

* For previous silicon revision A, the available analog gain settings are 1, 3, 5, 15, 24, 40, 72, and 120. See *ZSC31014_AFE_Settings.xls* for table values for revision A.

ZSC31014

RBic_{Lite}TM Digital Output Sensor Signal Conditioner



The Analog Mixed Signal Company



Table 1.4 Minimum Guaranteed Resolution for the Analog Gain Settings

Analog Gain = 1.5				
Input Span (mV/V)			Allowed Offset (mV/V)	Min. Guaranteed Resolution (Bits)
Min	Typ	Max		
289	400	529	69	12.7
235	325	430	118	12.4
181	250	331	168	12.1
126	175	231	218	11.6
90	125	165	251	11.1
54	75	99	284	10.3
43	60	79	294	10.0

Analog Gain = 3				
Input Span (mV/V)			Allowed Offset (mV/V)	Min. Guaranteed Resolution (Bits)
Min	Typ	Max		
145	200	265	34	12.7
123	170	225	54	12.5
101	140	185	74	12.2
80	110	145	94	11.9
58	80	106	114	11.4
36	50	66	134	10.7
22	30	40	147	10.0

Analog Gain = 6				
Input Span (mV/V)			Allowed Offset (mV/V)	Min. Guaranteed Resolution (Bits)
Min	Typ	Max		
65	90	119	24	12.6
61	85	112	27	12.5
51	70	93	37	12.2
43	60	79	44	12.0
40	55	73	47	11.9
36	50	66	50	11.7
29	40	53	57	11.4

Analog Gain = 12				
Input Span (mV/V)			Allowed Offset (mV/V)	Min. Guaranteed Resolution (Bits)
Min	Typ	Max		
36	50	66	9	12.7
30	42	56	14	12.5
25	34	45	19	12.2
19	26	34	24	11.8
13	18	24	30	11.3
7	10	13	35	10.4
6	8	11	36	10.1

ZSC31014

RBi_CLite™ Digital Output Sensor Signal Conditioner



The Analog Mixed Signal Company



Analog Gain = 24				
Input Span (mV/V)			Allowed Offset (mV/V)	Min. Guaranteed Resolution (Bits)
Min	Typ	Max		
18.1	25.0	33.1	4.3	12.7
15.2	21.0	27.8	6.9	12.5
12.3	17.0	22.5	9.6	12.2
9.4	13.0	17.2	12.2	11.8
6.5	9.0	11.9	14.9	11.3
3.6	5.0	6.6	17.5	10.4
2.9	4.0	5.3	18.2	10.1

Analog Gain = 48				
Input Span (mV/V)			Allowed Offset (mV/V)	Min. Guaranteed Resolution (Bits)
Min	Typ	Max		
8.7	12.0	15.9	0.4	12.7
7.2	10.0	13.2	1.7	12.4
5.8	8.0	10.6	2.9	12.1
4.3	6.0	7.9	4.2	11.7
2.9	4.0	5.3	5.4	11.1
2.2	3.0	4.0	6.7	10.7
1.4	2.0	2.6	7.3	10.1

Analog Gain = 96				
Input Span (mV/V)			Allowed Offset (mV/V)	Min. Guaranteed Resolution (Bits)
Min	Typ	Max		
4.3	6.0	7.9	1.2	12.7
2.9	4.0	5.3	2.6	12.1
1.8	2.5	3.3	3.6	11.4
1.4	2.0	2.6	3.9	11.1
1.2	1.6	2.1	4.2	10.8
0.9	1.3	1.7	4.3	10.5
0.7	1.0	1.3	4.5	10.1

Analog Gain = 192				
Input Span (mV/V)			Allowed Offset (mV/V)	Min. Guaranteed Resolution (Bits)
Min	Typ	Max		
1.81	2.50	3.31	1.0	12.4
1.45	2.00	2.65	1.3	12.1
1.08	1.50	1.98	1.6	11.7
0.90	1.25	1.65	1.8	11.4
0.72	1.00	1.32	1.9	11.1
0.51	0.70	0.93	2.1	10.6
0.36	0.50	0.66	2.3	10.1

ZSC31014

RBic_iLite™ Digital Output Sensor Signal Conditioner



The Analog Mixed Signal Company



2 Circuit Description

2.1. Signal Flow and Block Diagram

The ZSC31014 uses a charge-balancing ADC that provides low noise 14-bit samples. The system clock can operate at 1MHz (lower power, better noise performance) or 4MHz (faster sample rates). The PreAmp nulls its offset over temperature and offers a wide range of selectable analog gain settings. The on-chip digital signal processor (DSP) core uses coefficients stored in EEPROM to precisely calibrate/condition the amplified differential input signal. Temperature can be measured from an internal temperature sensor, which can be calibrated and output as well as used to compensate for temperature effects of the sensor bridge.

Direct interfacing to μ P controllers is facilitated via I²C™ digital protocol or optional SPI. I²C™ is used as the calibration interface and can be used in the final application. SPI is only supported for end applications.

Figure 2.1 ZSC31014 Block Diagram

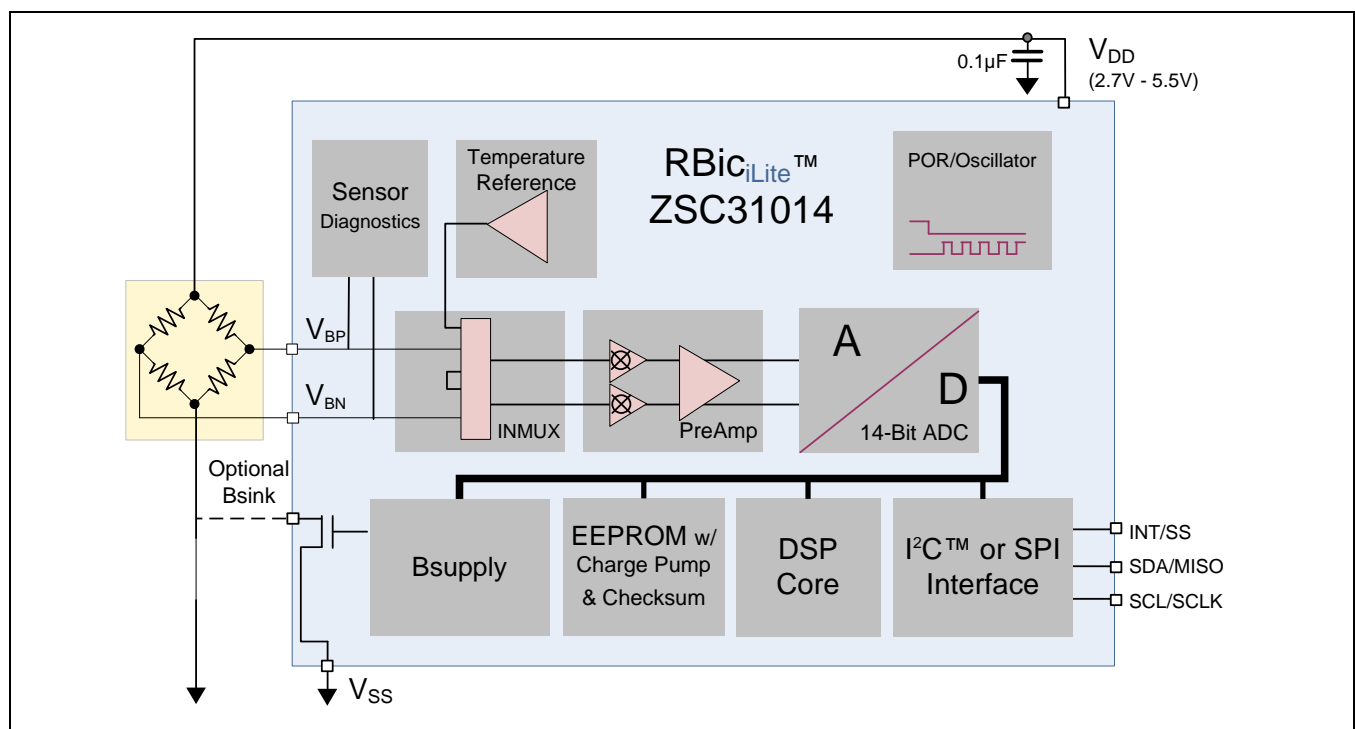

ZSC31014

RBic_{Lite}TM Digital Output Sensor Signal Conditioner

ZMDI[®]

The Analog Mixed Signal Company



2.2. Analog Front End

2.2.1. Preamplifier (PreAmp)

The preamplifier has a chopper-stabilized two-stage design. The first stage instrumentation-type amplifier has an internal auto-zero (AZ) function in order to prevent the second stage from being overdriven by the amplified offset. The overall chopper guarantees that the whole PreAmp has negligible offset.

There are eight analog gain settings selectable in EEPROM. The polarity of the gain can be changed by shifting the chopper phase between input and output by 180 degrees via the EEPROM setting Gain_Polarity. Changing the polarity can help prevent board layout crossings in cases where the sensor chip layout does not match the ZSC31014 pad/pin layout.

PreAmp_Gain for the bridge measurement is controlled by bits [6:4] in EEPROM Word 0F_{HEX} (B_Config register). PreAmp_Gain for temperature is set by bits [6:4] in Word 10_{HEX} (T_Config register). These 3 bits are referred to as [G2:G0]. See section 2.2.3 for recommended temperature measurements settings.

Table 2.1 Preamplifier Gain Control Signals [†]

G2	G1	G0	PreAmp_Gain
0	0	0	1.5
1	0	0	3
0	0	1	6
1	0	1	12
0	1	0	24
1	1	0	48
0	1	1	96
1	1	1	192

Gain Polarity for the bridge is controlled by bit [7] (Gain_Polarity) in the B_Config register.

Table 2.2 Gain Polarity Control Signal

Gain_Polarity	Overall Gain
0	(-1) * GAIN
1	(+1) * GAIN

[†] For previous silicon revision A, the available analog gain settings are 1 (G2:G0=000); 3 (G2:G0=100); 5 (G2:G0=001); 15 (G2:G0=101); 24 (G2:G0=010); 40 (G2:G0=011); 72 (G2:G0=110); and 120 (G2:G0=111).

ZSC31014

RBic_{Lite}TM Digital Output Sensor Signal Conditioner

ZMDI[®]

The Analog Mixed Signal Company



Before a measurement conversion is started, the PreAmp has a phase called nulling. During the nulling phase, the PreAmp measures its internal offset so that it can be removed during the measurement. It is especially useful at higher gains where a small offset could cause the PreAmp to saturate. If bit[12] of the configuration register is set to one, then the nulling feature is disabled as shown in Table 2.3. At lower PreAmp gains, nulling can adversely affect the linearity and ratiometricity of the part, so the recommended setting for this bit is zero for gains of 6 or higher and one for all other gains.

Table 2.3 Disable Nulling Control Signal

Disable_Nulling	Effect
0	Nulling is on
1	Nulling is off

2.2.2. Analog-to-Digital Converter

A 14-bit 2nd order charge-balancing analog-to-digital converter (ADC, A2D) is used to convert signals coming from the PreAmp. By default, each conversion is split into a 9-bit coarse conversion and a 5-bit fine conversion. During the coarse conversion, the amplified signal is integrated (averaged). One coarse conversion covers exactly 4 chopper periods of the PreAmp. A configurable setting stored in EEPROM allows quadrupling the period of the coarse conversion. In Table 3.7, see the LongInt bit in EEPROM words B_Config (0F_{HEX}) and T_Config (10_{HEX}). When LongInt = 1, the conversion is performed as 11 bits coarse + 3 bits fine. The advantage of this mode is more noise suppression; however, sampling rates will fall significantly because A2D conversion periods are quadrupled.

An auto-zero (AZ) measurement is performed periodically and subtracted from all ADC results used in calculations. This compensates for any drift of offset vs. temperature. The ADC uses switched capacitor technique and complete full-differential architecture to increase its stability and noise immunity.

Part of the switched capacitor network is a 4-bit digital-to-analog conversion (DAC) function, which allows adding or subtracting a defined offset value resulting in an A2D_Offset shift. This allows for a rough compensation of the bridge offset, which allows a higher PreAmp_Gain to be used and consequently more end resolution of the measured signal. Table 2.4 shows the A2D_Offset adjustment. Using this function, the ADC input range can be shifted in order to optimize the coverage of the sensor signal and sensor offset values as large as the sensor span can be processed without losing resolution.

The A2D_Offset setting for the bridge is controlled by bits [3:0] in Word 0F_{HEX} (B_Config). These 4 bits are referred to as [Z3:Z0]. Note: To collect uncalibrated raw bridge values from the ADC, the Offset_B coefficient must be programmed as shown in Table 2.4. Note: The ADC offset for the internal temperature measurement is trimmed at production test to avoid saturation and the setting, which is stored in bits [3:0] in word 10_{HEX} (T_Config), should not be changed (see Table 3.7).

ZSC31014

RBic_{Lite}TM Digital Output Sensor Signal Conditioner

ZMDI[®]

The Analog Mixed Signal Company



Table 2.4 A2D_Offset Signals

A2D_Offset[3:0]	Auto-Zero Output Count of A2D (+/- 250 Codes)	A2D Input Range [VREF]	A2D_Offset	Offset_B[15:0]
F _{HEX}	15360	-15/16 to 1/16	15/16	1C00 _{HEX}
E _{HEX}	14336	-7/8 to 1/8	7/8	1800 _{HEX}
D _{HEX}	13312	-13/16 to 3/16	13/16	1400 _{HEX}
C _{HEX}	12288	-3/4 to 1/4	3/4	1000 _{HEX}
B _{HEX}	11264	-11/16 to 5/16	11/16	0C00 _{HEX}
A _{HEX}	10240	-5/8 to 3/8	5/8	0800 _{HEX}
9 _{HEX}	9216	-9/16 to 7/16	9/16	0400 _{HEX}
8 _{HEX}	8192	-1/2 to 1/2	1/2	0000 _{HEX}
7 _{HEX}	7168	-7/16 to 9/16	7/16	FC00 _{HEX}
6 _{HEX}	6144	-3/8 to 5/8	3/8	F800 _{HEX}
5 _{HEX}	5120	-5/16 to 11/16	5/16	F400 _{HEX}
4 _{HEX}	4096	-1/4 to 3/4	1/4	F000 _{HEX}
3 _{HEX}	3072	-3/16 to 13/16	3/16	EC00 _{HEX}
2 _{HEX}	2048	-1/8 to 7/8	1/8	E800 _{HEX}
1 _{HEX}	1024	-1/16 to 15/16	1/16	E400 _{HEX}
0 _{HEX} ¹⁾	0	0 to 16/16	0	E000 _{HEX}

1) A setting of 0000_{BIN} for the A2D offset can only be used for internal temperature measurements, which are factory-trimmed (do not change default setting). If it is used for bridge measurements, it could lead to the auto-zero saturating, which results in poor performance of the IC.

Figure 2.2 shows a functional diagram of the ADC. The A/D block at the right side is assumed to be an ideal differential ADC. The summing node B models the offset voltage, which is caused by the tolerance of process parameters and other influences including temperature and changes of power supply. The summing node A adds a voltage, which is controlled by the digital input A2D_Offset. This internal digital-to-analog converter (DAC, D2A) uses binary-weighted capacitors, which are part of the switched capacitor network of the ADC. This DAC function allows optimal adjustment of the input voltage range of the ADC to the amplified output voltage range of the sensor. All signals in this diagram are shown as single-ended for simplicity in understanding the concept; all signals are actually differential. An auto-zero reading is accomplished by short-circuiting the differential ADC input.

ZSC31014

RBic_{Lite}TM Digital Output Sensor Signal Conditioner

ZMDI[®]

The Analog Mixed Signal Company



Figure 2.2 Functional Diagram of the ADC

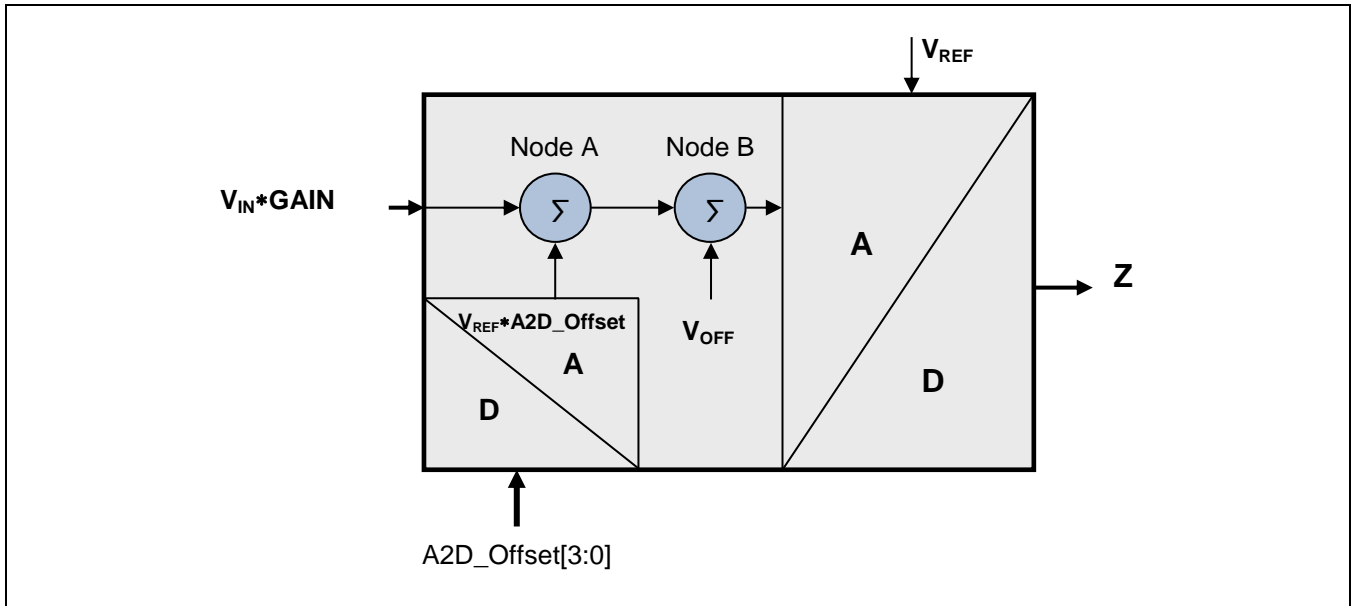

Digital representation of the input voltage as a signed number requires calculating the difference $Z_{\text{SENSOR}} - Z_{\text{AUTOZERO}}$.

$$Z_{\text{SENSOR}} = 2^{14} * (\text{GAIN} * V_{\text{IN}} / V_{\text{DD}} + \text{A2D_Offset} + V_{\text{OFF}} / V_{\text{REF}}) \quad (1)$$

$$Z_{\text{AUTOZERO}} = 2^{14} * (\text{A2D_Offset} + V_{\text{OFF}} / V_{\text{REF}}) \quad (2)$$

where

GAIN	PreAmp_Gain (B_Config bits [6:4] for bridge measurement; fixed value 6 for temperature measurement) (See Table 2.1)
A2D_Offset	Zero Shift of ADC (B_Config or T_Config bits [3:0]) (See Table 2.4)
V_{REF}	~ V _{DD} Supply Voltage to ZSC31014
V_{IN}	Input Voltage = (V _{BP} -V _{BN}) in differential mode; = (V _{BP} -V _{DD} /2) in half-bridge mode
V_{OFF}	Small random offset voltage that varies part-to-part and with temperature. The periodic auto-zero cycle will subtract this error.

ZSC31014

RBic_{Lite}TM Digital Output Sensor Signal Conditioner

ZMDI[®]

The Analog Mixed Signal Company



The digital output Z as a function of the analog input of the analog front-end (including the PreAmp) can be described as

$$Z = Z_{\text{SENSOR}} - Z_{\text{AUTOZERO}}$$

$$Z = 2^{14} * (\text{GAIN} * V_{\text{IN}} / V_{\text{REF}}) \quad (3)$$

With $V_{\text{REF}} = V_{\text{DD}} - V_{\text{BSink}}$ (see section 2.2.4) where V_{BSink} is the voltage at the BSINK pin.

2.2.3. Temperature Measurement

The temperature signal comes from an internal measurement of the die temperature. The temperature signal is generated from a bridge-type sensor using resistors with different TC values. Table 2.5 shows the characteristic parameters. This temperature signal can be corrected with offset, span, and 2nd order non-linearity coefficients. The corrected temperature can then be read on the digital output I²CTM or SPI with either an 8 or 11 bit resolution. The raw temperature reading can also be used to compensate the sensor bridge reading. 1st order Tco and Tcg, and 2nd order Tco and Tcg coefficients are available to correct sensor bridge offset and span variations with temperature.

Table 2.5 Parameters of the Internal Temperature Sensor Bridge

Parameter	Min	Typ	Max	Units
Sensitivity	0.28	0.38	0.5	mV/V/K
Offset voltage	-75		65	mV/V
Nonlinearity (-20 to 80°C) first order fit			2	°C
Nonlinearity (-20 to 80°C) second-order fit			0.25	°C
Bridge resistance	15	20	25	kΩ

NOTE: The T_CONFIG register description is given in section 2.2.5. Most fields within this EEPROM register are programmed to default settings on the production test and should not be changed. Only the LongInt field (bit 8) setting is user-selectable if desired. Other settings for the remaining T_Config bits might cause temperature measurements to saturate. Section 2.2.5 gives the details of how PreAmp_Gain and A2D_Offset Mode are configured for temperature measurements.

For ZSC31014 SOP8-packaged parts, the on-chip temperature sensor is calibrated by ZMDI using three temperature points: -40°C, room temperature (RT), and +85°C, which provides a 2nd-order fit. The error of the conditioned temperature output data at delivery is specified as ≤ 2.5 Kelvin over the full operational temperature range of -40 to +125°C.

Note: This calibration causes a change in the EEPROM default data in the EEPROM registers 0A_{HEX} to 0D_{HEX} for all SOP8-packaged forms of the ZSC31014. See Table 3.7 for details.

ZSC31014

RBic_{Lite}TM Digital Output Sensor Signal Conditioner



The Analog Mixed Signal Company



2.2.4. Bridge Supply (Bsink)

The ZSC31014 provides a Bsink (bridge sink) pin to drive the bottom of the sensor bridge. Internal to the ZSC31014, Bsink is driven by a large NMOS pull-down ($R_{DS(ON)} \approx 20\Omega$). There will be some IR drop across this device, but the Bsink node also forms the bottom reference of the ADC. Therefore, any ratiometricity error this IR drop would normally cause is cancelled out.

Bsink is turned on $190\mu s/50\mu s$ (depending on 1MHz or 4MHz clock setting) prior to the start of a conversion to allow settling time for the bridge and the internal front-end (PreAmp and ADC) path. The entire conversion is then performed, and Bsink is then turned off. This can achieve significant power savings when used in conjunction with slower update rates. For example, a $2.5k\Omega$ bridge would consume 2mA with a constant 5V bias. However, if used with the Bsink feature at an update rate of 6.35ms, the same bridge would draw on average only $112\mu A$ since it would be biased on only 5.6% of the time. Savings at slower update rates can be even more significant.

2.2.5. Analog Front-End Configuration

As shown in Figure 2.3, the analog front-end (AFE) has much flexibility/configurability in how its measurement is performed. The preferred settings for the AFE configuration are typically different for a bridge reading than for a temperature reading. The EEPROM contains two words for configuring the AFE for each measurement: B_Config ($0F_{HEX}$) and T_Config (10_{HEX}).

Figure 2.3 Format for AFE Configuration Registers B_Config and T_Config

Reserved [2:0]			Disable Nulling	PreAmp_Mux [1:0]		Bsink	LongInt	Gain_Polarity	PreAmp_Gain [2:0]			A2D_Offset [3:0]			
15	14	13	12	11	10	9	8	7	6	5	4	3	2	1	0

The B_Config register is loaded from EEPROM and written to the AFE configuration register just before a measurement of the bridge begins. The T_Config register is loaded from EEPROM and written to the AFE configuration register immediately before a temperature measurement begins. For more details, refer to Table 3.7, EEPROM words $0F_{HEX}$ (B_Config) and 10_{HEX} (T_Config), in section 3.6. Note: for T_Config, only bit 8 (LongInt) is user-configurable. All other settings are factory programmed and should not be changed.

ZSC31014

RBic_{Lite}TM Digital Output Sensor Signal Conditioner



2.3. Digital Signal Processor

A digital signal processor (DSP) is used for processing the converted differential signal as well as performing temperature correction and computing the temperature value for digital output.

2.3.1. Digital Core

The digital core reads correction coefficients from EEPROM and can correct for the following:

1. Signal offset (Offset_B term)
2. Signal gain (Gain_B term)
3. Temperature coefficient of the bridge offset 1st order (Tco term)
4. Temperature coefficient of the bridge gain 1st order (Tcg term)
5. Second-order non-linearity of signal (SOT_bridge term)
6. Second-order non-linearity of Tco (SOT_tco term)
7. Second-order non-linearity of Tcg (SOT_tcg term)

See sections 3.7 and 3.8 for a full discussion of calibration and correction math.

2.3.2. Normal Operation Mode

Two operation modes are available for normal operation: Update Rate Mode (continuous conversion at a selectable update rate) or Sleep Mode (low power). (See section 3.1.) Both modes can operate in either I²CTM digital output or SPI digital output. These selections are made in configuration registers of the EEPROM.

2.3.3. EEPROM

The EEPROM array contains the calibration coefficients for gain and offset, etc., and the configuration bits, such as output mode, update rate, etc. When programming the EEPROM, an internal charge pump voltage is used; therefore a high voltage supply is not needed. (See section 3.5 for instructions on programming the EEPROM.)

Important: After the ZMDI_Config_1 or ZMDI_Config_2 EEPROM word has been changed, the IC must be power cycled for the changes to be loaded.

The EEPROM array is arranged as twenty 16-bit words. Three words are dedicated to the customer serial number for module traceability. The integrity of the contents of the EEPROM array is ensured by a 16-bit signature word which is checked after each power-on of the device. The signature word is automatically updated whenever the Start_NOM command (starts Normal Operating Mode; see section 3.5) is executed after EEPROM contents have been changed.

After calibration is completed and all coefficients are written to EEPROM, the user can lock the EEPROM so that no further writes can occur (see section 3.6 regarding EEP_Lock, bits [15:13] of EEPROM word 02_{HEX}).

IMPORTANT: Care must be taken when performing this function. After the command to lock EEPROM, the next command *must* be Start_NOM so that the EEPROM checksum is calculated and written. If the part is power cycled instead, the lock will take effect, and the checksum will be wrong. In this case, the part will always output a diagnostic state, and since the EEPROM is permanently locked, it can never be recovered.

ZSC31014

RBic_{Lite}TM Digital Output Sensor Signal Conditioner



2.3.4. Digital Interface – I²CTM

The IC can communicate via an addressable two-wire (I²CTM) interface. Commands are available for the following:

- Sending calibration commands in Command Mode
- Starting measurements in Sleep Mode
- Reading data

The ZSC31014 uses an I²CTM-compatible communication protocol[‡] with support for the bit rates listed in Table 2.6.

Table 2.6 Supported I²CTM Bit Rates

Clock Setting	Bit Rates
4MHz	400kHz or 100kHz
1MHz	100kHz

See section 2.3.6 for clock setting details.

I²CTM is the protocol used during calibration (Command Mode). The ZSC31014 I²CTM slave address (00_{HEX} to 7F_{HEX}) is selected by bits [9:3] of EEPROM word 02_{HEX}. If the communication lock pattern Comm_lock (bits [5:3], EEPROM word 02_{HEX}) is programmed to 011, the device will respond only to this address. Otherwise, the device will respond to all I²CTM addresses. The factory setting for I²CTM slave address is 28_{HEX} with Comm_lock set.

When programmed as an I²CTM device, the INT/SS pin operates as an interrupt. The INT pin rises when new output data is ready and falls when the next I²CTM communication occurs. It is most useful if the part is configured in Sleep Mode to indicate to the system that a new conversion is ready.

See Figure 2.4 for the I²CTM timing diagram and Table 2.7 for definitions of the parameters shown in the timing diagram.

[‡] For more details, refer to <http://www.standardics.nxp.com> or other websites for this specification.

ZSC31014

RBiC_{Lite}TM Digital Output Sensor Signal Conditioner



The Analog Mixed Signal Company

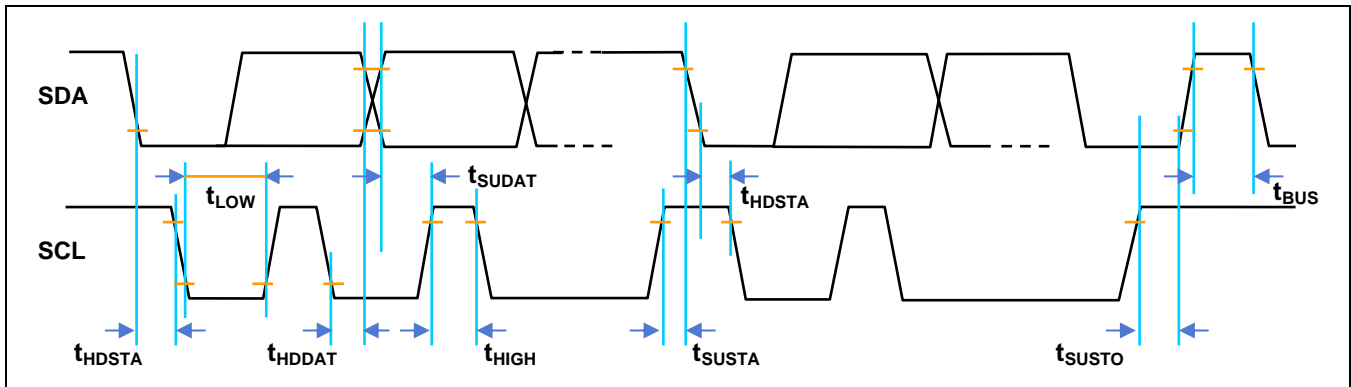

Table 2.7 I²CTM Parameters

PARAMETER	SYMBOL	MIN	TYP	MAX	UNITS
SCL clock frequency	f _{SCL}	100		400	kHz
Start condition hold time relative to SCL edge	t _{HDSTA}	0.1			μs
Minimum SCL clock low width ¹⁾	t _{LOW}	0.6			μs
Minimum SCL clock high width ¹⁾	t _{HIGH}	0.6			μs
Start condition setup time relative to SCL edge	t _{SUSTA}	0.1			μs
Data hold time on SDA relative to SCL edge	t _{HDDAT}	0			μs
Data setup time on SDA relative to SCL edge	t _{SUDAT}	0.1			μs
Stop condition setup time on SCL	t _{SUSTO}	0.1			μs
Bus free time between stop condition and start condition	t _{BUS}	2			μs

1) Combined low and high widths must equal or exceed minimum SCLK period.

Figure 2.4 I²CTM Timing Diagram



(See section 3.1 for data transmission details.)

Note: There are three differences in the ZSC31014 protocol compared with the original I²CTM protocol:

- Sending a start-stop condition without any transitions on the CLK line (no clock pulses in between) creates a communication error for the next communication, even if the next start condition is correct and the clock pulse is applied. An additional start condition must be sent, which results in restoration of proper communication.
- The restart condition—a falling SDA edge during data transmission when the CLK clock line is still high—creates the same situation. The next communication fails, and an additional start condition must be sent for correct communication.
- A falling SDA edge is not allowed between the start condition and the first rising SCL edge. If using an I²CTM address with the first bit 0, SDA must be held low from the start condition through the first bit.

ZSC31014

RBic_{Lite}TM Digital Output Sensor Signal Conditioner

ZMDI[®]

The Analog Mixed Signal Company



2.3.5. Digital Interface – SPI

SPI is available only as half duplex (read-only from the ZSC31014). SPI cannot be used in the calibration environment (Command Mode) because it does not support receiving commands. SPI speeds of up to 200kHz can be supported in 1MHz Mode, and up to 800kHz can be supported in 4MHz Mode. See Figure 2.5 for the SPI timing diagram and Table 2.8 for definitions of the parameters shown in the timing diagram.

Table 2.8 SPI Parameters

PARAMETER	SYMBOL	MIN	TYP	MAX	UNITS
SCLK clock frequency (4MHz clock)	f_{SCL}	50		800	kHz
SCLK clock frequency (1MHz clock)	f_{SCL}	50		200	kHz
SS drop to first clock edge	t_{HDSS}	2.5			μ s
Minimum SCLK clock low width ¹⁾	t_{LOW}	0.6			μ s
Minimum SCLK clock high width ¹⁾	t_{HIGH}	0.6			μ s
Clock edge to data transition	t_{CLKD}	0		0.1	μ s
Rise of SS relative to last clock edge	t_{SUSS}	0.1			μ s
Bus free time between rise and fall of SS	t_{BUS}	2			μ s

1) Combined low and high widths must equal or exceed minimum SCLK period.

Figure 2.5 SPI Bus Data Output Timing

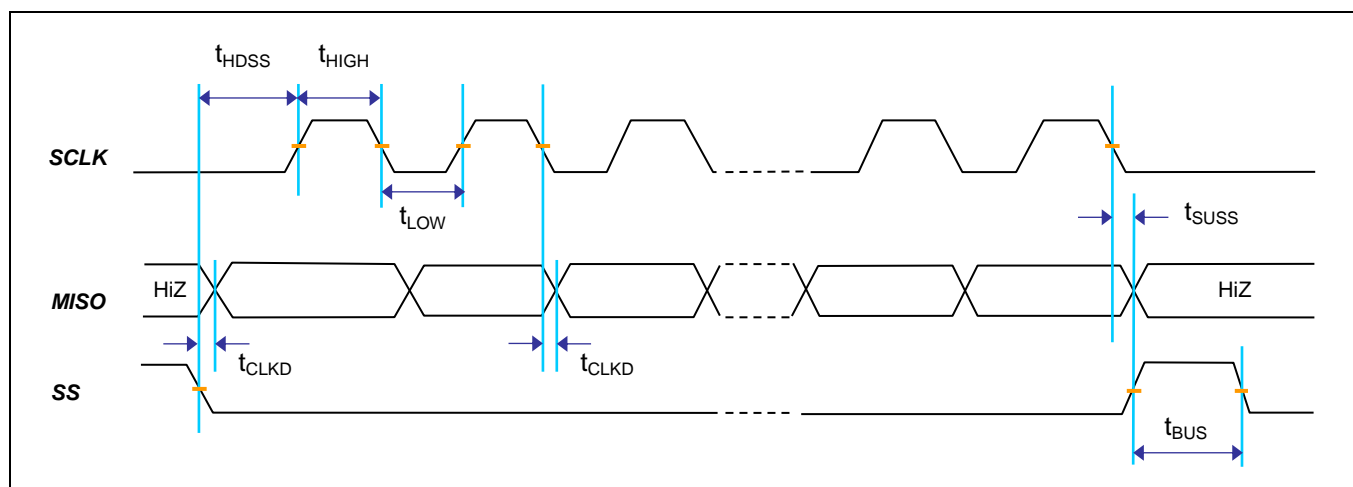

(See section 3.1 for data transmission details.)

ZSC31014

RBic_{Lite}TM Digital Output Sensor Signal Conditioner

ZMDI[®]

The Analog Mixed Signal Company



2.3.6. Clock Generator / Power-On Reset (CLKPOR)

The ZSC31014 has an internal 4MHz temperature-compensated oscillator that provides the time base for all operations. This oscillator feeds into a 4:1 post scalar that can optionally form the clock source for the device. Using ClkSpeed (bit 3 of EEPROM word 01_{HEX}; see section 3.6) the user can select a 4MHz clock or a 1MHz digital core clock for the ZSC31014. If the fast response times and sampling periods provided by the 4MHz clock are not needed, then choosing the 1MHz clock will result in better noise performance.

If the power supply exceeds the power-on reset level (see Table 1.3), the reset signal de-asserts and the clock generator starts working at the selected frequency (approximately 1MHz or 4MHz). The exact value only influences the conversion cycle time. To minimize the oscillator error as the V_{DD} voltage changes, an on-chip regulator supplies the oscillator block.

2.4. Diagnostic Features

The ZSC31014 offers a full suite of diagnostic features to ensure robust system operation in the most “mission-critical” applications. The diagnostic states are indicated by a transmission of the status of the 2 MSBs of the bridge high byte data.

Table 2.9 2 MSB of Data Packet Encoding

Status Bits (2 MSBs of Output Packet)	Definition
00	Normal operation, good data packet
01	Device in Command Mode
10	Stale data: Data that has already been fetched since the last measurement cycle. Note: If a data fetch is performed before or during the first measurement after power-on reset, then “stale” will be returned, but this data is actually invalid because the first measurement has not been completed.
11	Diagnostic condition exists

When the two MSBs are 11, one of the following faults listed below is indicated.

- Invalid EEPROM signature
- Loss of bridge positive or negative
- Bridge input short
- Loss of bridge source
- Loss of bridge sink

All diagnostics are detected in the next measurement cycle and reported in the subsequent data fetch. Once a diagnostic is reported, the diagnostic status bits will not change unless both the cause of the diagnostic is fixed and a power-on-reset is performed.

ZSC31014

RBic_{Lite}TM Digital Output Sensor Signal Conditioner

ZMDI[®]

The Analog Mixed Signal Company



2.4.1. EEPROM Integrity

The contents of the EEPROM are protected by a 16-bit signature generated by a multiple input shift register (MISR). This signature is generated and stored in EEPROM (word 12_{HEX}) upon leaving Command Mode if an EEPROM write has occurred. This signature is re-generated and checked for a match after Power-On-Reset prior to entering Normal Operation Mode. If the generated signature fails to match, the part will output a diagnostic state on the output. The customer ID fields (words 00_{HEX}, 0E_{HEX}, and 13_{HEX}) are not included in the signature.

2.4.2. Sensor Connection Check

Four dedicated comparators constantly check the range of the bridge inputs (BP/BN) to ensure they are within the envelope of $0.15 \cdot V_{DD}$ to $0.85 \cdot V_{DD}$ during all conversions. The two sensor inputs have switched ohmic paths to ground and if not driven, would discharge during the fine conversion phase. If any of the connections to the bridge break, this mechanism will detect it and put the ASIC in a diagnostic state. This diagnostic feature can be enabled/disabled with bit 0 of Diag_cfg (bits [2:1] of EEPROM word 02_{HEX}).

2.4.3. Sensor Short Check

If a short occurs between BP/BN (bridge inputs), it would normally produce a mid-range output signal and therefore would not be detected as a fault. If enabled via bit 1 of Diag_cfg (bits [2:1] of EEPROM word 02_{HEX}), the sensor short diagnostic detects BP/BN shorts. After the measurement cycle of the bridge, it will deliberately pull the BP bridge input to ground for 8 μ sec with a 1MHz clock or 2 μ sec with a 4MHz clock. At the end of this 8 μ sec/2 μ sec window, it will check to see if the BN input “followed” it down below the 15%VDD comparator check point. If so, a short must exist between BP/BN, and the part will output a diagnostic state. The bridge will have a minimum recovery time of 100 μ sec for a 1MHz clock or 25 μ sec for a 4MHz clock prior to the next measurement.



3 Functional Description

3.1. General Working Mode

See Figure 3.1 for an overview of the general working mode of the ZSC31014. There are three types of commands as detailed in Table 3.1.

Table 3.1 Command Types

Type	Description	Communication Supported	Reference Sections
Data Fetch (DF)	Used to fetch data in any mode	I ² C TM and SPI	Sections 3.2.2 and 3.3.2
Measurement Request (MR)	Used to start measurements in Sleep Mode	I ² C TM and SPI	Sections 3.1.2, 3.3.1, and 3.4.1
Calibration Commands	Used to calibrate part in Command Mode	I ² C TM Only	Section 3.5

On system power-on reset (POR), the ZSC31014 wakes as an I²CTM device regardless of the digital protocol programmed in EEPROM. It then waits for a Start_CM command for 6ms if EEPROM is unlocked or for 1.5ms if EEPROM is locked (the command window). If the ZSC31014 receives the Start_CM command during the command window, it goes into Command Mode. The communication protocol in Command Mode is always I²CTM regardless of the setting programmed in EEPROM. During Command Mode, the device executes commands sent by the I²CTM master. Command Mode is primarily used in the calibration environment. See section 3.5 for details on Command Mode. The part remains in Command Mode until it receives the Start_NOM command, which starts the Normal Operation Mode.

If instead during the power-on sequence, the command window expires without receiving a Start_CM, the device will immediately assume its programmed output mode (I²CTM or SPI) and start performing the required A2D conversions (Temp, AZ, Bridge). When Update Mode has been selected, the first corrected data will be written to the digital interface within 6ms of power-on with a 1MHz clock and the EEPROM locked.

Operation after the power-on sequence depends on whether the part is programmed in Sleep Mode or in Update Mode. In Sleep Mode, the part waits for commands from the master before taking measurements. In Update Mode, data is taken at a fixed, selectable rate. More detail is given about Update Mode and Sleep Mode in sections 3.1.1 and 3.1.2 respectively.

ZSC31014

RBiC_{Lite}TM Digital Output Sensor Signal Conditioner



The Analog Mixed Signal Company



Figure 3.1 General Working Mode

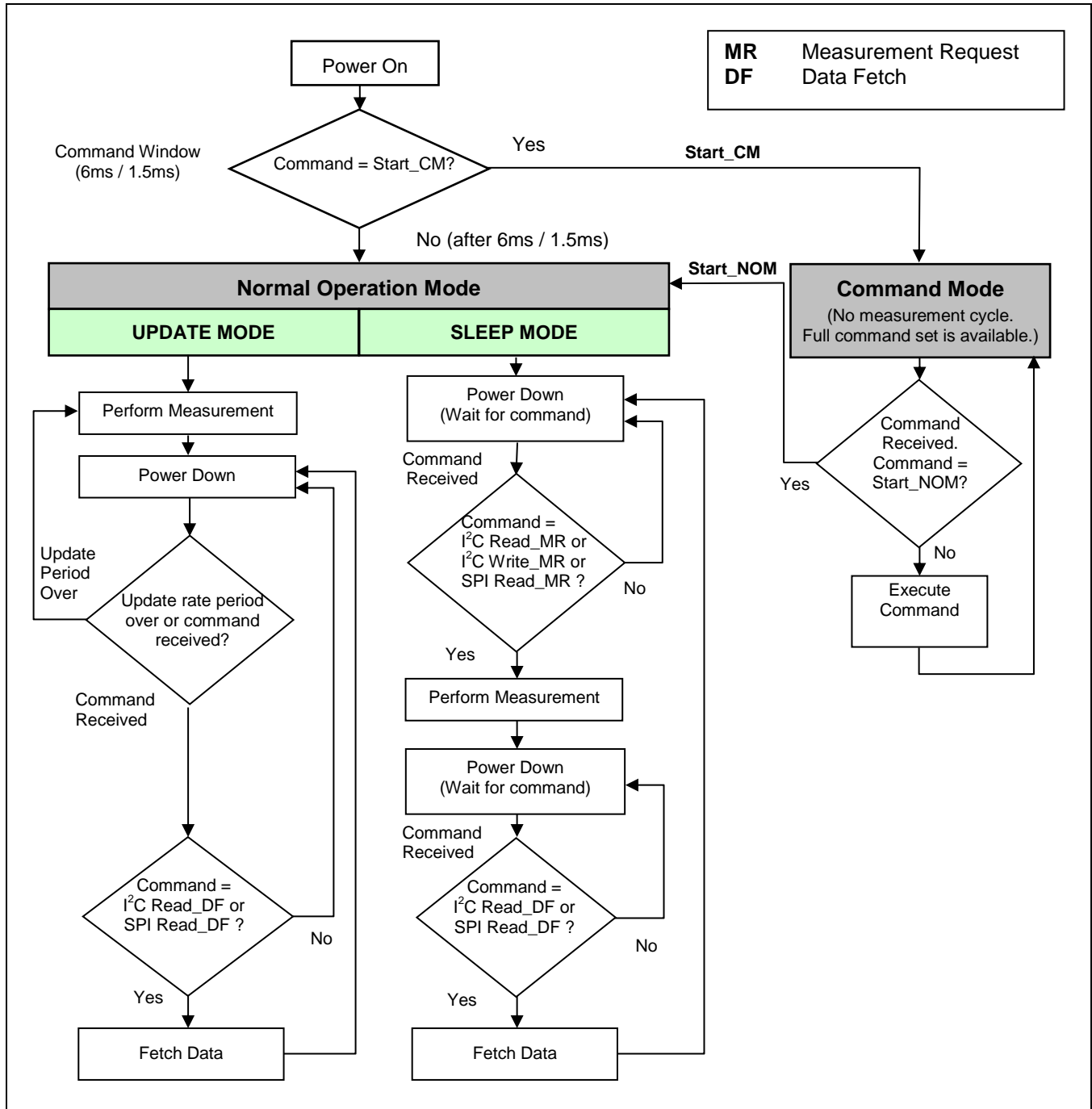

ZSC31014

RBic_{Lite}TM Digital Output Sensor Signal Conditioner

ZMDI[®]

The Analog Mixed Signal Company



3.1.1. Update Mode

In Update Mode, the digital core will perform measurements and correction calculations at a selectable update rate and update the I²CTM/SPI output register. The power-on measurement sequence for the Update Mode is shown in Figure 3.2.

Figure 3.2 Power-Up Sequence and Timing for Update Mode with EEPROM Locked[§]

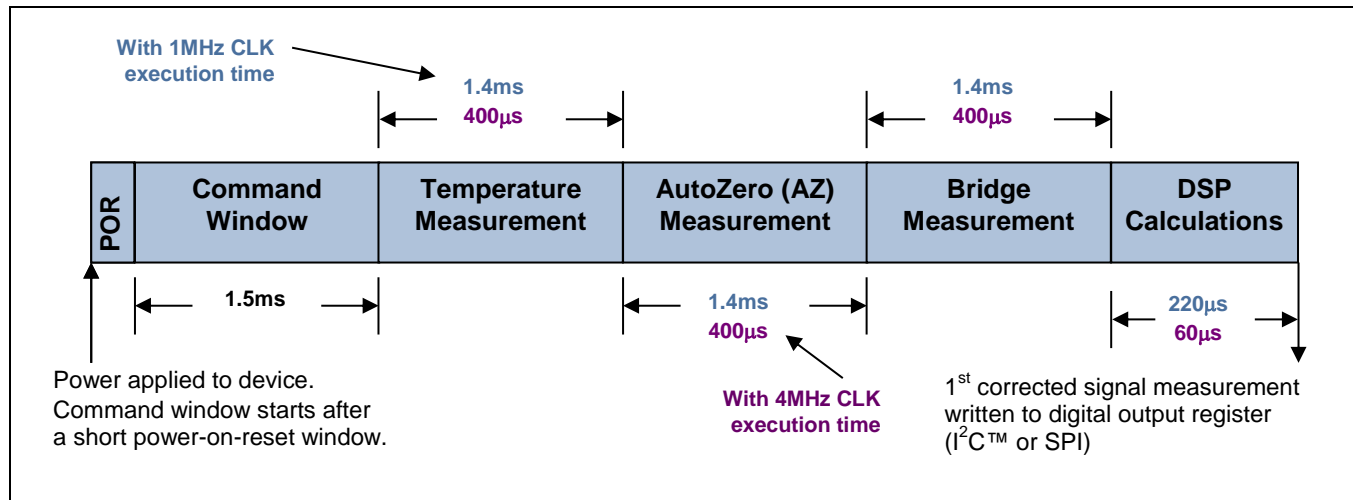

If the part is programmed for the fastest update rate, conversions will continue to happen after the power-up sequence. If the ZSC31014 is not in the fastest update rate, the part will power down after writing to the digital output register. The duration of the power-down period is determined by the Update_Rate setting (bits [7:6] in EEPROM word 01_{HEX}; see section 3.6) and the digital core clock speed (see section 2.3.6). See Table 3.2 and Table 3.3 for the update rates. After the power-down period has expired, the ZSC31014 will power up; take another *bridge* reading followed by calculations; write to the digital output register; and power down. Temperature and Auto-Zero (AZ) are slower moving quantities but must be updated periodically. When the part is configured in Update Mode, these two quantities are measured periodically (referred to as special measurements).

As illustrated in Figure 3.3, valid data output to the digital register occurs after the measurement and the DSP calculations are complete. At this point the master can fetch the data in I²CTM or SPI with a Read_DF command. Specifics of the Read_DF command are given in sections 3.2 and 3.3. After a valid output has been read by the master, the status bits are set to “stale,” indicating that the measurement has not been updated since the last Read_DF. This mode allows the application to simply read the digital output at any time and be assured the data is no older than the selected update period. See Table 2.9 for more information on the status bits. The chip should be polled at a frequency slower than 20% more of the update rate period listed in Table 3.2 and Table 3.3.

In I²CTM Mode only, the INT/SS pin will assume the INT (interrupt) function. Instead of polling until a “valid” response is received, the application can look for a rise on the INT pin. This will indicate that the measurement and calculations are complete and new valid data is ready to be read on the I²CTM interface.

[§] When EEPROM is not locked, the command window is 4.5ms longer (= 6ms). All time values shown are typical; for the worst case values, multiply by 1.15 (nominal frequency ±15%).

ZSC31014

RBic_{Lite}TM Digital Output Sensor Signal Conditioner

ZMDI[®]

The Analog Mixed Signal Company



Table 3.2 Update Rate Settings (Normal Integration Mode: 9 Coarse + 5 Fine)

Update_Rate	Update Period/1MHz Clock ¹⁾	Update Period/4MHz Clock ¹⁾	Measurement Cycles between Special Measurements (Temperature or AZ)
00 ²⁾	1.6ms	0.5ms	255
01	5.0ms	1.5ms	127
10	25.0 ms	6.5ms	31
11	125.0ms	32.0ms	15

1) All time values shown are typical; for worst case values, multiply by 1.15 (nominal frequency $\pm 15\%$).
2) With the fastest update rate setting, there is no power down period between measurements.

Table 3.3 Update Rate Settings (Long Integration Mode: 10 Coarse + 5 Fine)

Update_Rate	Update Period/1MHz Clock ¹⁾	Update Period/4MHz Clock ¹⁾	Number of Measurement Cycles between Special Measurements (Temperature or AZ)
00 ²⁾	5ms	1.5ms	255
01	8.5ms	2.5ms	127
10	30.0 ms	7.5ms	31
11	130.0ms	33.0ms	15

1) All time values shown are typical; for worst case values, multiply by 1.15 (nominal frequency $\pm 15\%$).
2) With the fastest update rate setting, there is no power down period between measurements.

ZSC31014

RBiC_{Lite}TM Digital Output Sensor Signal Conditioner

ZMDI[®]

The Analog Mixed Signal Company



Figure 3.3 Measurement Sequence in Update Mode

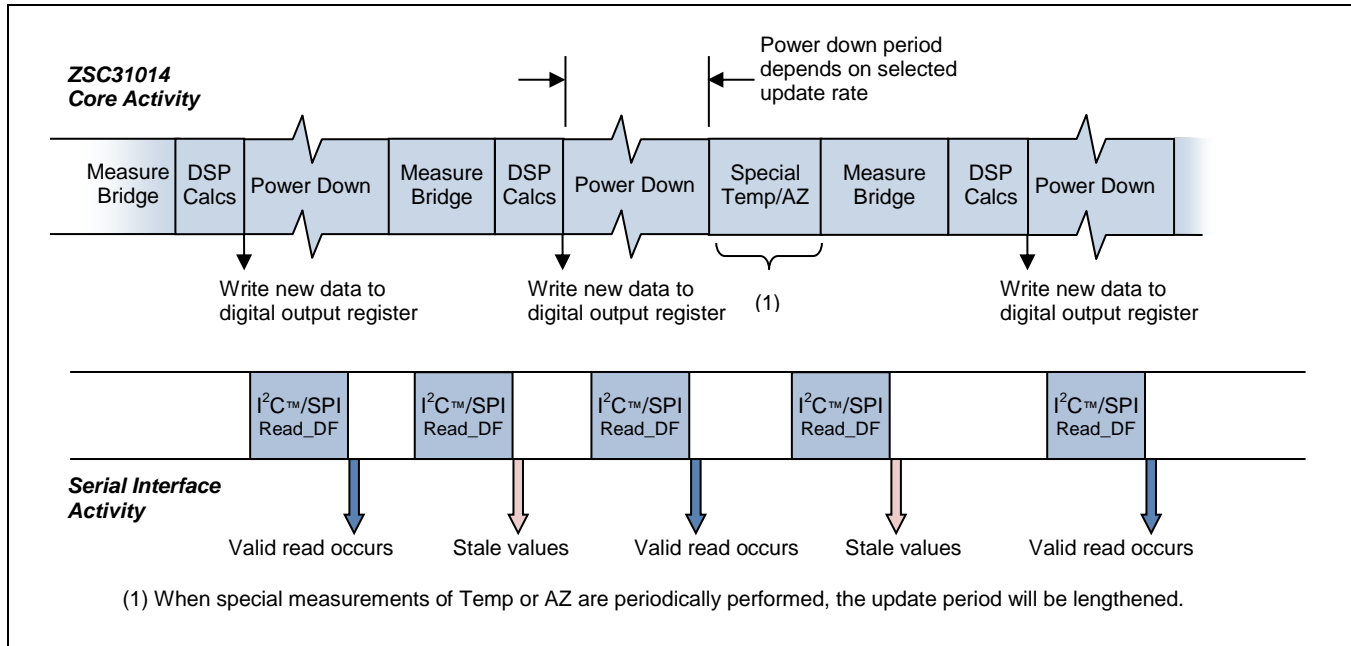

The benefit of slower update rates is power savings. If the update period is increased, the device will be powered down for longer periods of time, so power consumption will be reduced. When a special measurement occurs, a BP/BN (bridge) measurement will occur directly afterward. The update period during this special measurement will be increased by one conversion time over the standard measurement period.

3.1.2. Sleep Mode

In Sleep Mode, after the command window, the ZSC31014 will power down until the master sends a Read_MR (either I²C™ or SPI) or a Write_MR (I²C™ only). Specifics on the Read_MR and Write_MR commands are given in sections 3.2.1, 3.3.1, and 3.4.1. A Read_MR or Write_MR wakes the ZSC31014 and starts a measurement cycle. If the command is Read_MR, the part performs temperature, auto-zero (AZ), and a bridge measurement followed by the DSP correction calculations (see Figure 3.4). If the command is Write_MR, the part measures only the bridge and performs the correction calculations using previously measured temperature and auto-zero data (see Figure 3.5). Valid values are then written to the digital output register, and the ZSC31014 powers down again.

Following a measurement sequence and before the next measurement can be performed, the master must send a Read_DF command, which will fetch the data as 2, 3 or 4 bytes (see section 3.2.2), without waking the ZSC31014. When a Read_DF is performed, the data packet returned will be the last measurement made with the status bits set to "valid." See Table 2.9 for more information on the status bits. After the Read_DF is completed, the status bits will be set to "stale." The next Read_MR or Write_MR will wake the part again and start a new measurement cycle. If a Read_DF is sent while the measurement cycle is still in progress, then the status bits of the packet will read as "stale." The chip should be polled at a frequency slower than 20% more than the Sleep Mode response times listed in Table 3.4 and Table 3.5.

ZSC31014

RBic_{Lite}TM Digital Output Sensor Signal Conditioner

ZMDI[®]

The Analog Mixed Signal Company



Note: Data is considered invalid from system power-on reset (POR) until the first measured data is written to the digital register. Sending an I²CTM Write_MR as the first command after power-on delivers invalid data; even though the status bits report it as “valid”. This is due to the correction calculations being performed with an uninitialized temperature and Auto-Zero value.

In I²CTM Mode only, the INT/SS pin will assume the INT (interrupt) function. Instead of polling until a “valid” response is received, the application can look for a rise on the INT pin. This will indicate that the measurement and calculations are complete, and new valid data is ready to be read on the I²CTM interface.

Table 3.4 Sleep Mode Response Times (Normal Integration Mode: 9 Coarse + 5 Fine)

Measurement Request	Response/1MHz Clock ¹⁾	Response/4MHz Clock ¹⁾
Read MR	4.5ms	1.5ms
Write MR	1.5 ms	0.5ms

1) All time values shown are typical; for worst case values, multiply by 1.15 (nominal frequency ±15%).

Table 3.5 Sleep Mode Response Times (Long Integration Mode: 10 Coarse + 5 Fine)

Measurement Request	Response/1MHz Clock ¹⁾	Response/4MHz Clock ¹⁾
Read MR	12ms	4.5ms
Write MR	5.5 ms	1.5ms

1) All time values shown are typical; for worst case values, multiply by 1.15 (nominal frequency ±15%).

ZSC31014

RBic_{Lite}TM Digital Output Sensor Signal Conditioner



The Analog Mixed Signal Company



Figure 3.4 Power-on Sequence in Sleep Mode for I²CTM or SPI Read_MR (Typical Timing Values^{})**

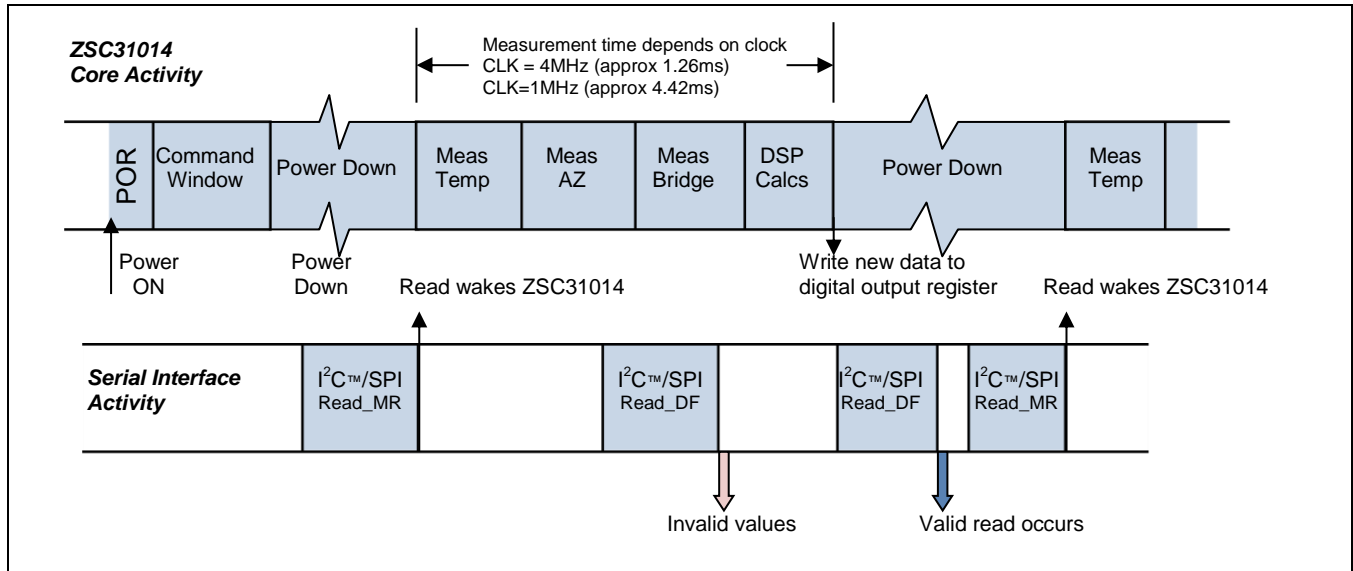
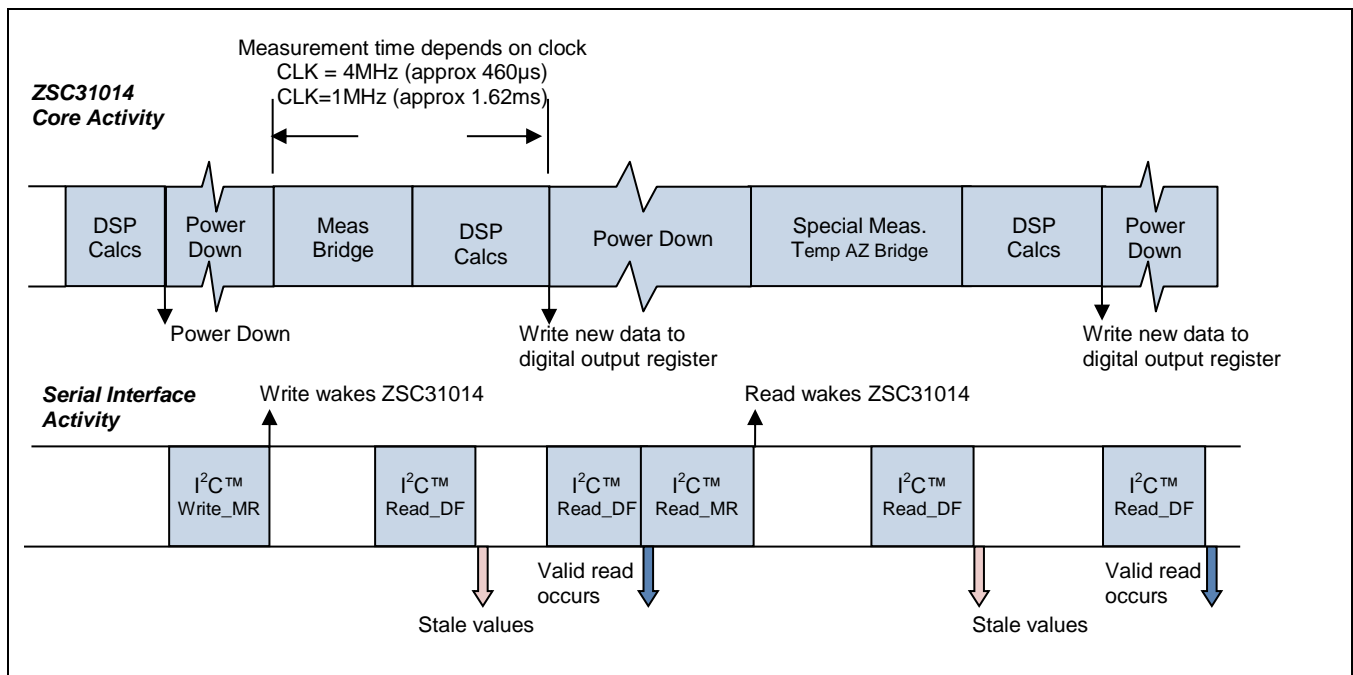

Figure 3.5 Sequence during Sleep Mode Using an I²CTM Write_MR to Wake Up (Typical Timing Values^{})**



^{**} All time values shown are typical; for worst case values, multiply by 1.15 (nominal frequency ±15%).

ZSC31014

RBi_CLite™ Digital Output Sensor Signal Conditioner



The Analog Mixed Signal Company



3.2. ZSC31014 Read Operations with I²C™

For read operations, the I²C™ master command starts with the 7bit slave address with the 8th bit =1 (READ). The ZSC31014 as the slave sends an acknowledge (ACK) indicating success. The ZSC31014 has four I²C™ read commands: Read_MR, Read_DF2, Read_DF3, and Read_DF4. Figure 3.6 shows the structure of the measurement packet for three of the four I²C™ read commands, which are explained in sections 3.2.1 and 3.2.2.

Figure 3.6 I²C™ Measurement Packet Reads

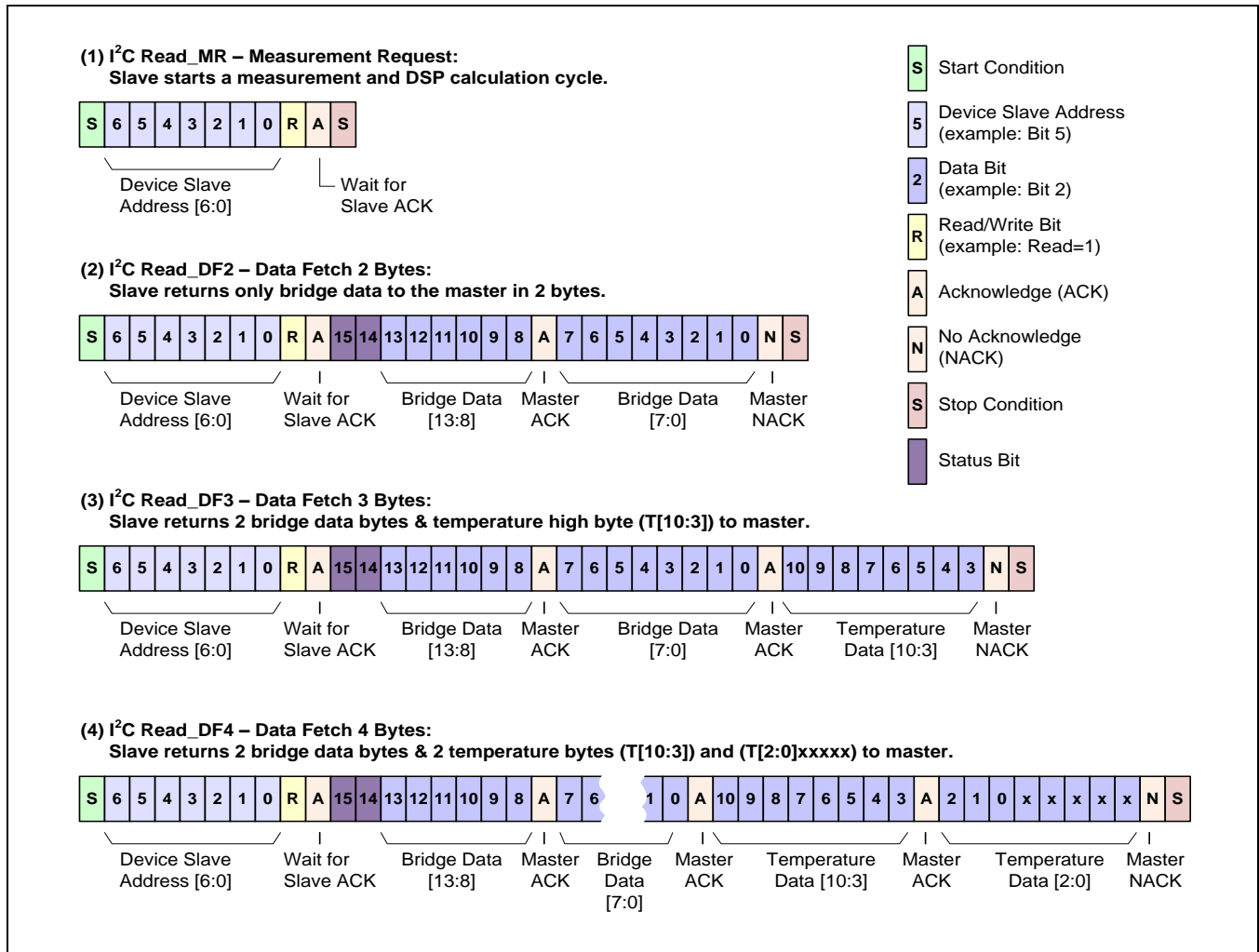



3.2.1. I²CTM Read_MR (Measurement Request)

The Read_MR (see example 1 in Figure 3.6) communication contains only the slave address and the READ bit (1) sent by the master. After the ZSC31014 responds with the slave ACK, the master must create a stop condition. This is only used in Sleep Mode (see section 3.1.2) to wake up the device and start a complete measurement cycle (including the special measurements) followed by the DSP calculations and writing the results to the digital output register.

Note: The I²CTM Read_MR function can also be accomplished using the I²CTM Read_DF2 or Read_DF3 command and ignoring the “stale” data that will be returned.

3.2.2. I²CTM Read_DF (Data Fetch)

For Data Fetch commands, the number of data bytes returned by the ZSC31014 is determined by when the master sends the NACK and stop condition. For the Read_DF3 data fetch command (Data Fetch 3 Bytes; see example 3 in Figure 3.6), the ZSC31014 returns three bytes in response to the master sending the slave address and the READ bit (1): two bytes of bridge data with the two status bits as the MSBs and then 1 byte of temperature data (8-bit accuracy). After receiving the required number of data bytes, the master sends the NACK and stop condition to terminate the read operation.

For the Read_DF4 command, the master delays sending the NACK and continues reading an additional final byte to acquire the full corrected 11-bit temperature measurement. In this case, the last 5 bits of the final byte of the packet are undetermined and should be masked off in the application.

The Read_DF2 command is used if corrected temperature is not required. The master terminates the READ operation after the two bytes of bridge data (see example 2 in Figure 3.6).

3.3. SPI Read Operations

The SPI interface of ZSC31014 can be programmed for falling-edge MISO change or rising-edge MISO change (see SPI_Polarity, bit 0 of EEPROM word 02_{HEX}, in section 3.6).

3.3.1. SPI Read_MR (Measurement Request)

A special SPI Read_MR command is used for waking up the part in Sleep Mode (see section 3.1.2). It performs a measurement cycle including the special measurements and a correction calculation. The SPI Read_MR command only requires that the SS line be dropped low for a minimum of 8 μ s then raised high again. The rise of SS will trigger the part to power up and perform the measurements.

Figure 3.7 SPI Read_MR

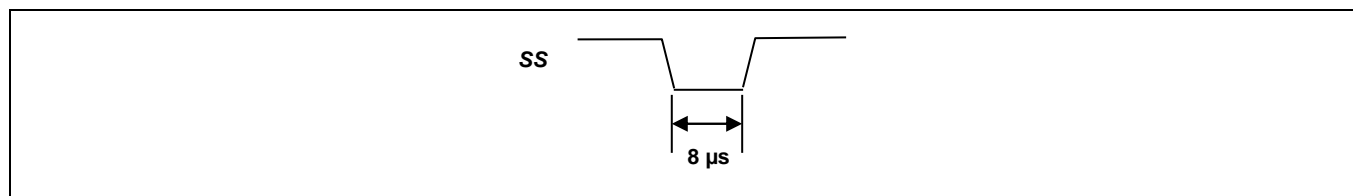

Note: The SPI Read_MR function can also be accomplished using the SPI Read_DF command (see section 3.3.2) and ignoring the “stale” data that will be returned.

ZSC31014

RBic_{Lite}TM Digital Output Sensor Signal Conditioner



The Analog Mixed Signal Company



3.3.2. SPI Read_DF (Data Fetch)

For simplifying explanations and illustrations, only falling edge SPI polarity will be discussed in the following sections. The SPI interface will have data change after the falling edge of SCLK. The master should sample MISO on the rise of SCLK. The entire output packet is 4 bytes (32 bits). The high bridge data byte comes first, followed by the low bridge data byte. Then 11 bits of corrected temperature (T[10:0]) are sent: first the T[10:3] byte and then the {T[2:0],xxxxx} byte. The last 5 bits of the final byte are undetermined and should be masked off in the application. If the user only requires the corrected bridge value, the read can be terminated after the 2nd byte. If the corrected temperature is also required but only at an 8-bit resolution, the read can be terminated after the 3rd byte is read.

Figure 3.8 SPI Output Packet with Falling Edge SPI_Polarity

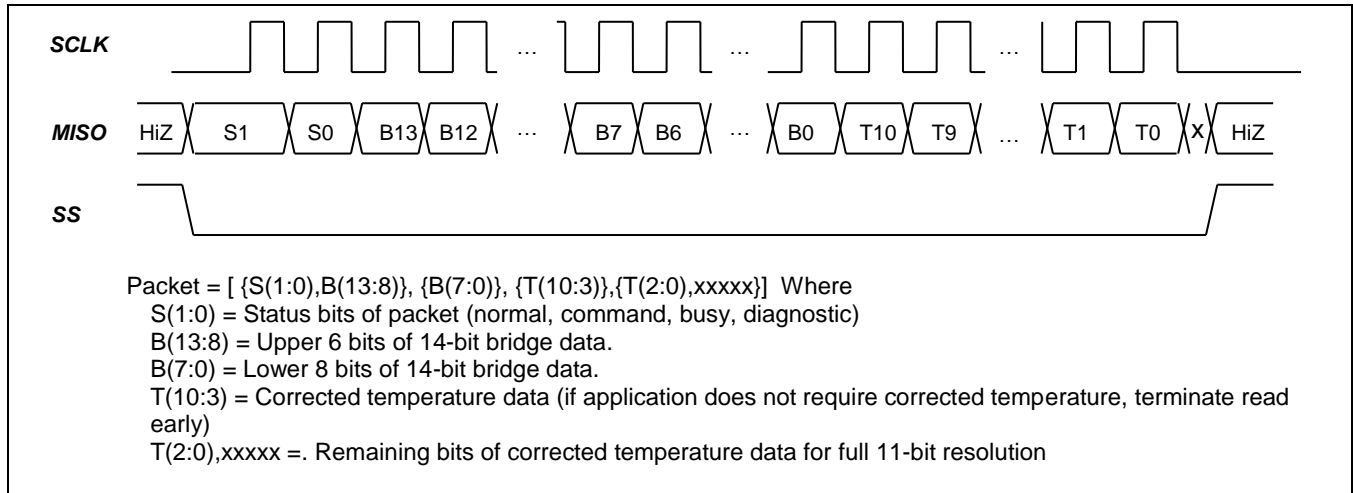



3.4. I²CTM Write Operations

For write operations, the I²CTM master command starts with the 7-bit slave address with the 8th bit =0 (WRITE). The ZSC31014 as the slave sends an acknowledge (ACK) indicating success. The ZSC31014 has two general I²CTM write command formats: I²CTM WRITE and I²CTM Write_MR. Figure 3.9 shows the structure of the write packet for the two I²CTM write commands, which are explained in sections 3.4.1 and 3.4.2.

Figure 3.9 I²CTM Measurement Packet Writes

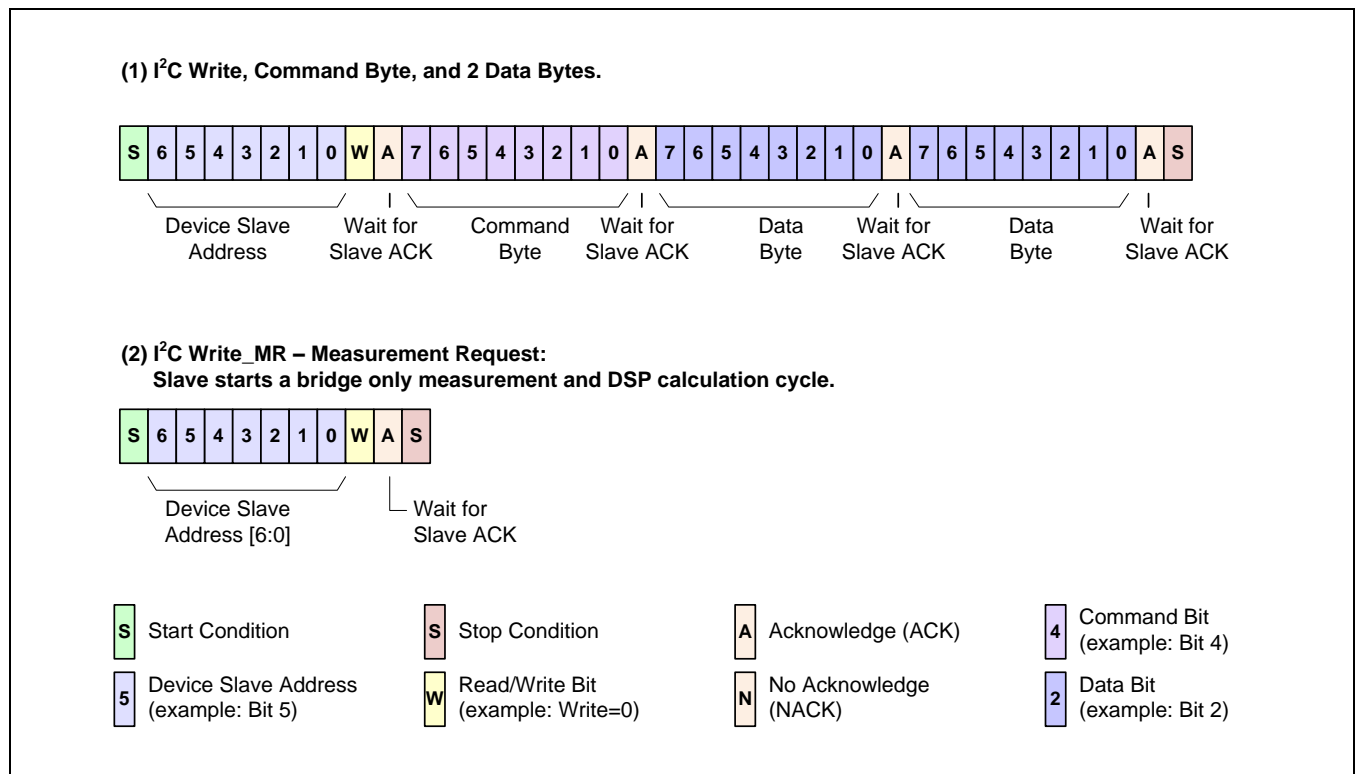

3.4.1. I²CTM Write_MR (Measurement Request)

Write_MR is a special I²CTM write operation, which only includes the 7-bit slave address and the WRITE bit (0). This command can only be sent in Sleep Mode (see section 3.1.2). It wakes up the part and starts a measurement cycle for the bridge values only (no special measurement) and a DSP calculation based on former AZ and Temperature values. After finishing the calculation with valid results written to the digital register, the ZSC31014 powers down again and a Read_DF (see section 3.2.2) is required to read the valid values. See Figure 3.9 for an illustration of Write_MR.

Note: The I²CTM Write_MR function can also be accomplished using the I²CTM WRITE command with “don’t care” data in Sleep Mode.

ZSC31014

RBic_{Lite}TM Digital Output Sensor Signal Conditioner

ZMDI[®]

The Analog Mixed Signal Company



3.4.2. Command Mode I²CTM Write Operations

With the exception of the I²CTM Write_MR command, write operations typically only occur in Command Mode (see section 3.1) and are only supported for the I²CTM protocol. Command Mode write commands to the ZSC31014 are in 32-bit packets. After the write command byte (7-bit slave address followed by 0 for write), the next (2nd) byte is considered the command byte, and the subsequent two bytes form a 16-bit data field. See Figure 3.9 for an illustration of the Command Mode I²CTM WRITE command sequence.

Note: If data is not needed for the command, all zeros must be supplied as data to complete the 32-bit packet.

3.5. Command/Data Pair Encoding in Command Mode

In Command Mode (see section 3.1), the master uses the I²CTM protocol to send 4-byte commands to the ZSC31014 (see section 3.4.2). Table 3.6 shows the available commands with their description and encodings.

Note: Only the commands listed in Table 3.6 below are valid for the ZSC31014 in Command Mode. Other encodings might cause unpredictable results. If data is not needed for the command, zeros must be supplied as data to complete the 32-bit packet.

Table 3.6 Command List and Encodings

Command Byte 8 Command Bits (Hex)	Third and Fourth Bytes 16 Data Bits(Hex)	Description	Processing Time ^{††} 4MHz/1MHz
00 _{HEX} to 13 _{HEX}	0000 _{HEX}	EEPROM Read of addresses 00 _{HEX} to 13 _{HEX} . After this command has been sent and executed, a data fetch of three bytes must be performed. The first byte will be a response byte, which should be a 5A _{HEX} , and then the next two bytes will be the EEPROM data.	10µs
40 _{HEX} to 53 _{HEX}	YYYY _{HEX} (Y= data)	Write to EEPROM addresses 00 _{HEX} to 13 _{HEX} . If the command is an EEPROM write, then the 16 bits of data sent will be written to the address specified in the 6 LSBs of the command byte.	15ms
80 _{HEX}	0000 _{HEX}	Start_NOM => Ends Command Mode and transitions to Normal Operation Mode. When a Start_NOM command is executed, a flag is checked to see if EEPROM was programmed during Command Mode. If so, the device will regenerate the checksum and update the signature EEPROM word.	15ms if EEPROM signature is updated; 10µs otherwise
A0 _{HEX}	0000 _{HEX}	Start_CM => Start Command Mode; used to enter Command Mode. Start_CM is only valid during the power-on command window.	10µs

^{††} All time values shown are typical; for worst case values, multiply by 1.15 (nominal frequency ±15%).

ZSC31014

RBic_{Lite}TM Digital Output Sensor Signal Conditioner

ZMDI[®]

The Analog Mixed Signal Company



In Command Mode, the INT/SS pin operates as an interrupt by rising when a command has finished executing. With this form of positive acknowledgement, the master does not need to poll the ZSC31014 to determine if the command was received and completed. This is particularly useful for commands that take the ZSC31014 longer to complete, such as EEPROM programming. If needed, a response byte of 5A_{HEX} can be fetched after a command has been executed. In the case of an EEPROM read, this byte is included as the first byte of the data fetch.

3.6. EEPROM Bits

Table 3.7 provides a summary of the EEPROM contents, which determine ZSC31014 operation, including communication, and store the calibration coefficients and the customer ID. The ZSC31014 EEPROM contains twenty 16-bit words. See section 3.4.2 for instructions for writing to the EEPROM in Command Mode via the I²CTM interface.

Table 3.7 EEPROM Word/Bit Assignments

Note: IC default setting bits with the designation “s” indicate that the bit is set at the factory to a value determined at final test/programming.

EEPROM Word	Bit Range	IC Default	Description	Note
00 _{HEX}	7:0	SSSS SSS _{BIN} X coordinate on wafer test	Cust_ID0	Customer ID word 0 (combines with EEPROM words 0E _{HEX} and 13 _{HEX} to form the customer ID). Programmed with the X coordinate on wafer test, the wafer number, and the 3 LSBs of lot number as the default values.
	12:8	S SSS _{BIN} Wafer number		
	15:13	SSS _{BIN} 3 LSBs of lot number		

ZSC31014

RBi_CLite™ Digital Output Sensor Signal Conditioner



The Analog Mixed Signal Company



EEPROM Word	Bit Range	IC Default	Description	Note										
01 _{HEX}	ZMDI_Config_1			Bits in the ZMDI_Config_1 EEPROM word control the following settings. <i>Important:</i> IC must be power-cycled after changes to this word.										
	2:0	001 _{BIN}	ZMDI Reserved	Must preserve factory settings.										
	3	1 _{BIN}	ClkSpeed	Digital Core Clock Frequency 0 = 4MHz 1 = 1MHz										
	4	0 _{BIN}	Comm_Type	Serial Communication Type 0 = I ² C™ 1 = SPI										
	5	0 _{BIN}	Sleep_Mode	Normal Operation Mode 0 = Update Mode 1 = Sleep Mode										
	7:6	01 _{BIN}	Update_Rate	The following time values are typical; for worst case values, multiply by 1.15 (nominal frequency ±15%). <table border="0"> <tr> <td>1MHz Clock</td> <td>4MHz Clock</td> </tr> <tr> <td>00 = 1.6ms</td> <td>00 = 0.5ms</td> </tr> <tr> <td>01 = 5.0ms</td> <td>01 = 1.5ms</td> </tr> <tr> <td>10 = 25.0ms</td> <td>10 = 6.5ms</td> </tr> <tr> <td>11 = 125.0ms</td> <td>11 = 32.0ms</td> </tr> </table>	1MHz Clock	4MHz Clock	00 = 1.6ms	00 = 0.5ms	01 = 5.0ms	01 = 1.5ms	10 = 25.0ms	10 = 6.5ms	11 = 125.0ms	11 = 32.0ms
	1MHz Clock	4MHz Clock												
	00 = 1.6ms	00 = 0.5ms												
	01 = 5.0ms	01 = 1.5ms												
	10 = 25.0ms	10 = 6.5ms												
11 = 125.0ms	11 = 32.0ms													
8	0 _{BIN}	ZMDI Reserved	Must preserve factory settings.											
9	0 _{BIN}	SOT_curve	Type of second-order curve correction on bridge. If set to 0, the bridge SOT will correct for a parabolic curve. If set to 1, the bridge SOT will correct for an S-shaped curve.											
11:10	00 _{BIN}	TC_Sign	TC_Sign[0] = 1, Tco is a negative number. TC_Sign[1] = 1, Tcg is a negative number.											
15:12	0000 _{BIN}	SOT_Sign	SOT_Sign[0] = 1, SOT_bridge is negative. SOT_Sign[1] = 1, SOT_tco is negative. SOT_Sign[2] = 1, SOT_tcg is negative. SOT_Sign[3] = 1, SOT_T is negative.											

ZSC31014

RBic_{Lite}TM Digital Output Sensor Signal Conditioner



The Analog Mixed Signal Company



EEPROM Word	Bit Range	IC Default	Description	Note
02 _{HEX}	ZMDI_Config_2			Bits in the ZMDI_Config_2 EEPROM word control the following settings. <i>Important:</i> IC must be power-cycled after changes to this word.
	0	0 _{BIN}	SPI_Polarity	Configure clock polarity of SPI interface 0 = MISO changes on SCLK negative edge. 1 = MISO changes on SCLK positive edge.
	2:1	00 _{BIN}	Diag_cfg	2-bit diagnostic configuration field. Diag_cfg[0] enables sensor connection check. Diag_cfg[1] enables sensor short checking.
	9:3	0101000 _{BIN}	Slave_Addr	I ² C TM slave address (default = 28 _{HEX}). Valid range is 00 _{HEX} to 7F _{HEX} .
	12:10	011 _{BIN} ^{‡‡}	Comm_lock	Communications address lock 011 => locked All other => unlocked When communication is locked, I ² C TM communication will only respond to its programmed address. Otherwise if communication is unlocked, I ² C TM will respond to any address.
	15:13	000 _{BIN}	EEP_Lock	EEPROM lock 011 = locked All other = unlocked When EEPROM is locked, the internal charge pump is disabled and the EEPROM can never be programmed again. NOTE: Next command must be Start_NOM so that the signature is calculated and written to EEPROM before power down. ^{§§}
03 _{HEX}	15:0	0000 _{HEX}	Offset_B	Signed 16-bit offset for bridge correction. See section 2.2.2 for details on programming Offset_B for raw data collection.
04 _{HEX}	14:0	010 0000 0000 0000 _{BIN}	Gain_B	15-bit magnitude of bridge gain. Always positive. Unity is 2000 _{HEX} .
	15	0 _{BIN}	Gain8x_B	Multiple Gain_B by 8 0 = Gain_B x 1 1 = Gain_B x 8

^{‡‡} The Comm_lock is set to 000_{BIN} during wafer test for parts manufactured in workweek (ww) ≥13/2009.

^{§§} Caution: If the part is power cycled instead, the lock will take effect, and the checksum will be permanently wrong. In this case, the part will always output a diagnostic state.

ZSC31014

RBi_CLite™ Digital Output Sensor Signal Conditioner



The Analog Mixed Signal Company



EEPROM Word	Bit Range	IC Default	Description	Note
05 _{HEX}	15:0	0000 _{HEX}	Tcg	Coefficient for temperature correction of bridge gain term. Tcg = 16-bit magnitude of Tcg term with sign determined by TC_Sign[1].
06 _{HEX}	15:0	0000 _{HEX}	Tco	Coefficient for temperature correction of bridge offset term. Tco = 16-bit magnitude of Tco term with sign determined by TC_Sign[0].
07 _{HEX}	15:0	0000 _{HEX}	SOT_tco	2 nd order term applied to Tco. This term is a 16-bit magnitude with sign determined by SOT_Sign[1].
08 _{HEX}	15:0	0000 _{HEX}	SOT_tcg	2 nd order term applied to Tcg. This term is a 16-bit magnitude with sign determined by SOT_Sign[2].
09 _{HEX}	15:0	0000 _{HEX}	SOT_bridge	2 nd order term applied to the bridge measurement. This term is a 16-bit magnitude with sign determined by SOT_Sign[0]. SOT_curve selects parabolic or S-shaped fit.
0A _{HEX}	15:0	Die: 0000 _{HEX} SOP8: dddd _{HEX}	Offset_T	Temperature offset correction coefficient.***
0B _{HEX}	14:0	Die: 010 0000 0000 0000 _{BIN} SOP8: ddd ddd dddd ddd _{BIN}	Gain_T	Temperature gain correction coefficient.***
	15	0 _{BIN}	Gain8x_T	Multiple Gain_T by 8 0 = Gain_T x 1 1 = Gain_T x 8
0C _{HEX}	15:0	Die: 0000 _{HEX} SOP8: dddd _{HEX}	SOT_T	2 nd order term applied to the temperature reading. This term is a 16-bit magnitude with sign determined by SOT_Sign[3]. Always a parabolic fit.***
0D _{HEX}	15:0	Die: 0000 _{HEX} SOP8: dddd _{HEX}	T _{SETL}	Stores raw temperature reading at the temperature at which low calibration points were taken.***
0E _{HEX}	15:0	00ss _{HEX} Set to Y coordinate (ss) at the factory.	Cust_ID1	Customer ID word 1 (combines with EEPROM words 00 _{HEX} and 13 _{HEX} to form the customer ID). Programmed with the Y coordinate of wafer location as the default.

*** For SOP8 packaged parts, the letter "d" refers to the factory setting that is calculated at ZMDI production test for calibrated temperature data. Before performing a new sensor calibration over temperature, change the "d" values to the die default setting. Also see section 2.2.3.

ZSC31014

RBi_CLite™ Digital Output Sensor Signal Conditioner



The Analog Mixed Signal Company



EEPROM Word	Bit Range	IC Default	Description	Note																												
0F _{HEX}	B_Config Register			Front-end configuration for bridge measurement																												
	3:0	1000 _{BIN}	A2D_Offset [3:0]	<table border="1"> <thead> <tr> <th>[3:0]</th> <th>A2D Range</th> <th>[3:0]</th> <th>A2D Range</th> </tr> </thead> <tbody> <tr> <td>1010</td> <td>5/8 to 3/8</td> <td>0100</td> <td>-1/4 to 3/4</td> </tr> <tr> <td>1001</td> <td>-9/16 to 7/16</td> <td>0011</td> <td>-3/16 to 13/16</td> </tr> <tr> <td>1000</td> <td>-1/2 to 1/2</td> <td>0010</td> <td>-1/8 to 7/8</td> </tr> <tr> <td>0111</td> <td>-7/16 to 9/16</td> <td>0001</td> <td>-1/16 to 15/16</td> </tr> <tr> <td>0110</td> <td>-3/8 to 5/8</td> <td>0000</td> <td>0 to 16/16</td> </tr> <tr> <td>0101</td> <td>-5/16 to 11/16</td> <td colspan="2">See Table 2.4 for more details.</td> </tr> </tbody> </table>	[3:0]	A2D Range	[3:0]	A2D Range	1010	5/8 to 3/8	0100	-1/4 to 3/4	1001	-9/16 to 7/16	0011	-3/16 to 13/16	1000	-1/2 to 1/2	0010	-1/8 to 7/8	0111	-7/16 to 9/16	0001	-1/16 to 15/16	0110	-3/8 to 5/8	0000	0 to 16/16	0101	-5/16 to 11/16	See Table 2.4 for more details.	
	[3:0]	A2D Range	[3:0]	A2D Range																												
	1010	5/8 to 3/8	0100	-1/4 to 3/4																												
	1001	-9/16 to 7/16	0011	-3/16 to 13/16																												
	1000	-1/2 to 1/2	0010	-1/8 to 7/8																												
	0111	-7/16 to 9/16	0001	-1/16 to 15/16																												
	0110	-3/8 to 5/8	0000	0 to 16/16																												
	0101	-5/16 to 11/16	See Table 2.4 for more details.																													
6:4	010 _{BIN}	PreAmp_Gain [2:0]	<table border="1"> <thead> <tr> <th>[2:0] PreAmp_Gain</th> <th>GAIN</th> </tr> </thead> <tbody> <tr> <td>000</td> <td>1.5</td> </tr> <tr> <td>100</td> <td>3</td> </tr> <tr> <td>001</td> <td>6</td> </tr> <tr> <td>101</td> <td>12</td> </tr> <tr> <td>010</td> <td>24</td> </tr> <tr> <td>110</td> <td>48</td> </tr> <tr> <td>011</td> <td>96</td> </tr> <tr> <td>111</td> <td>192</td> </tr> </tbody> </table>	[2:0] PreAmp_Gain	GAIN	000	1.5	100	3	001	6	101	12	010	24	110	48	011	96	111	192											
[2:0] PreAmp_Gain	GAIN																															
000	1.5																															
100	3																															
001	6																															
101	12																															
010	24																															
110	48																															
011	96																															
111	192																															
7	1 _{BIN}	Gain_Polarity	Gain polarity: 0=negative gain, 1=positive gain																													
8	1 _{BIN}	LongInt	If 1, selects long integration period (11-coarse + 3 fine), which results in lower noise, slower conversion; If 0, the conversion is done as (9 coarse + 5 fine).																													
9	1 _{BIN}	Bsink	If 1, Bsink pull-down will be enabled during the measurement.																													
11:10	10 _{BIN}	PreAmp_Mux [1:0]	<table border="1"> <thead> <tr> <th>PreAmp_Mux [1:0]</th> <th>Measurement</th> </tr> </thead> <tbody> <tr> <td>10</td> <td>Bridge</td> </tr> <tr> <td>11</td> <td>Half-bridge input</td> </tr> </tbody> </table>	PreAmp_Mux [1:0]	Measurement	10	Bridge	11	Half-bridge input																							
PreAmp_Mux [1:0]	Measurement																															
10	Bridge																															
11	Half-bridge input																															
12	0 _{BIN} (Must be 0 if using PreAmp Gain ≥ 6.)	Disable_Nulling	Disable Nulling 0 = Nulling On 1 = Nulling Off (Use this setting if PreAmp gain <6.)																													
15:13	000 _{BIN}	ZMDI Reserved	Must preserve factory settings.																													

ZSC31014

RBic_{Lite}TM Digital Output Sensor Signal Conditioner



The Analog Mixed Signal Company



EEPROM Word	Bit Range	IC Default	Description	Note																												
10 _{HEX}	T_Config Register			Front-end configuration for temperature measurement																												
	3:0	SSSS _{BIN}	A2D_Offset [3:0]	<p>DO NOT CHANGE default setting. Trimmed at production test to avoid saturation.</p> <table border="1"> <thead> <tr> <th>[3:0]</th> <th>A2D Range</th> <th>[3:0]</th> <th>A2D Range</th> </tr> </thead> <tbody> <tr> <td>1010</td> <td>5/8 to 3/8</td> <td>0100</td> <td>-1/4 to 3/4</td> </tr> <tr> <td>1001</td> <td>-9/16 to 7/16</td> <td>0011</td> <td>-3/16 to 13/16</td> </tr> <tr> <td>1000</td> <td>-1/2 to 1/2</td> <td>0010</td> <td>-1/8 to 7/8</td> </tr> <tr> <td>0111</td> <td>-7/16 to 9/16</td> <td>0001</td> <td>-1/16 to 15/16</td> </tr> <tr> <td>0110</td> <td>-3/8 to 5/8</td> <td>0000</td> <td>0 to 16/16</td> </tr> <tr> <td>0101</td> <td>-5/16 to 11/16</td> <td></td> <td>See Table 2.4 for more details.</td> </tr> </tbody> </table>	[3:0]	A2D Range	[3:0]	A2D Range	1010	5/8 to 3/8	0100	-1/4 to 3/4	1001	-9/16 to 7/16	0011	-3/16 to 13/16	1000	-1/2 to 1/2	0010	-1/8 to 7/8	0111	-7/16 to 9/16	0001	-1/16 to 15/16	0110	-3/8 to 5/8	0000	0 to 16/16	0101	-5/16 to 11/16		See Table 2.4 for more details.
	[3:0]	A2D Range	[3:0]	A2D Range																												
	1010	5/8 to 3/8	0100	-1/4 to 3/4																												
	1001	-9/16 to 7/16	0011	-3/16 to 13/16																												
	1000	-1/2 to 1/2	0010	-1/8 to 7/8																												
	0111	-7/16 to 9/16	0001	-1/16 to 15/16																												
	0110	-3/8 to 5/8	0000	0 to 16/16																												
	0101	-5/16 to 11/16		See Table 2.4 for more details.																												
	6:4	001 _{BIN}	PreAmp_Gain[2:0]	<p>DO NOT CHANGE default setting. Temperature measurement requires a gain of 6 to avoid saturation.</p> <table border="1"> <thead> <tr> <th>[6:4]</th> <th>Gain</th> <th>[6:4]</th> <th>Gain</th> </tr> </thead> <tbody> <tr> <td>000</td> <td>1.5</td> <td>010</td> <td>24</td> </tr> <tr> <td>100</td> <td>3</td> <td>110</td> <td>48</td> </tr> <tr> <td>001</td> <td>6</td> <td>011</td> <td>96</td> </tr> <tr> <td>101</td> <td>12</td> <td>111</td> <td>192</td> </tr> </tbody> </table>	[6:4]	Gain	[6:4]	Gain	000	1.5	010	24	100	3	110	48	001	6	011	96	101	12	111	192								
[6:4]	Gain	[6:4]	Gain																													
000	1.5	010	24																													
100	3	110	48																													
001	6	011	96																													
101	12	111	192																													
7	1 _{BIN}	Gain_Polarity	<p>DO NOT CHANGE default setting. Gain_Polarity must be positive for internal temperature measurements.</p> <p>Gain polarity; 0 = negative, 1= positive gain.</p>																													
8	0 _{BIN}	LongInt	If 1, selects long integration period (11-coarse + 3 fine), for lower noise, slower conversion; otherwise, the conversion is (9 coarse + 5 fine).																													
9	0 _{BIN}	Bsink	DO NOT CHANGE default setting. Bsink must be disabled for internal temperature measurements.																													
11:10	01 _{BIN}	PreAmp_Mux [1:0]	DO NOT CHANGE default setting.																													
12	0 _{BIN}	Disable_Nulling	DO NOT CHANGE default setting. Nulling is enabled for temperature measurements																													
15:13	000 _{BIN}	ZMDI Reserved	DO NOT CHANGE default setting. Must preserve factory settings.																													
11 _{HEX}	7:0	0011SSSS _{BIN}	Osc_Trim	DO NOT CHANGE default setting. Must preserve factory settings.																												
	15:8		Unused																													

ZSC31014

RBic_{Lite}TM Digital Output Sensor Signal Conditioner

ZMDI[®]

The Analog Mixed Signal Company



EEPROM Word	Bit Range	IC Default	Description	Note
12 _{HEX}	15:0	-	Signature	Generated through a linear feedback shift register (LFSR). After EEPROM changes, the next command that is sent must be Start_NOM so that the signature is calculated and written to EEPROM. Signature checked on power-up to ensure EEPROM contents integrity.
13 _{HEX}	15:0	MSB of Lot Number	Cust_ID2	Customer ID word 2 (combines with EEPROM words 00 _{HEX} and 0E _{HEX} to form customer ID). Programmed with the MSB of the lot number as the default.

3.7. Calibration Sequence

Although the ZSC31014 can work with many different sources of differential signals, assume a pressure bridge for the following discussion on calibration.

Calibration essentially involves collecting raw signal and temperature data from the device for different known pressures and temperatures. This raw data can then be processed by the calibration master (assumed to be a PC), and the calculated calibration coefficients can then be written to EEPROM.

ZMDI can provide software and hardware with samples to perform the calibration. Below is a brief overview of the steps involved in calibrating a ZSC31014. See *ZSC31014_SSC_Evaluation_Kit_Description_Rev_X.xy.pdf* for a complete description and detailed examples.

For SOP8-packaged parts, the on-chip temperature sensor is calibrated by ZMDI production test with an error $\leq 2.5K$ over the full operational temperature range of $-40^{\circ}C$ to $+125^{\circ}C$. The resulting IC-specific correction coefficients required for the signal conditioning of the temperature output data are stored in the EEPROM registers 0A_{HEX} to 0D_{HEX} and must remain unchanged if these temperature signal conditioning coefficients are used without re-calibration over temperature. If instead the SOP8 parts are recalibrated, EEPROM registers 0A_{HEX} to 0D_{HEX} must be changed to the same default values as for the die prior to calibration (see Table 3.7).

There are three main steps to calibration:

1. Assigning a unique identification to the IC. This identification is programmed in EEPROM and can be used as an index into a database stored on the calibration PC. This database will contain all the raw values of bridge readings and temperature readings for that part, as well as the known pressure and temperature the bridge was exposed to. This unique identification can be stored in the three 16-bit EEPROM registers dedicated to customer ID.
2. Data collection. Data collection involves getting uncorrected data from the bridge at different known pressures and temperatures. This data is then stored on the calibration PC using the unique identification of the device as the index to the database.
3. Coefficient calculation and storage in EEPROM. After enough data points have been collected to calculate all the desired coefficients, then the coefficients can be calculated by the calibrating PC and written to the EEPROM of the device.

ZSC31014

RBic_{Lite}TM Digital Output Sensor Signal Conditioner



Step 1 – Assigning Unique Identification

Assigning a unique identification number is as simple as using the EEPROM WRITE command (see section 3.5) to write the identification number to Cust_ID0 (EEPROM word 00_{HEX}), Cust_ID1 (EEPROM word 0E_{HEX}), and Cust_ID2 (EEPROM word 13_{HEX}); see section 3.6). These three 16-bit registers allow for more than 280 trillion unique devices.

Step 2 – Data Collection

The number of unique points (pressure and/ or temperature) at which calibration must be performed depends on the requirements of the application and the behavior of the resistive bridge in use. The minimum number of points required is equal to the number of bridge coefficients to be corrected. The available calibration methods and the required number of points for each are listed below:

1. 2-point calibration can be used if only a gain and offset term are needed for a bridge with no temperature compensation for either term.
2. 3-point calibration would be used to obtain 1st order compensation for either a Tco or Tcg term but not both.
3. 3-point calibration could also be used to obtain 2nd order correction for the bridge (SOT_bridge) but no temperature compensation of the bridge output.
4. 4-point calibration would be used to obtain 1st order compensation for both Tco and Tcg.
5. 4-point calibration could also be used to obtain 1st order compensation for either Tco or Tcg (but not both) and a 2nd order correction for the bridge measurement.
6. 5-point calibration could be used to obtain both 1st order Tco correction and 1st order Tcg correction, plus a 2nd order correction that could be applied to one and only one of the following: 2nd order Tco (SOT_tco); 2nd order Tcg (SOT_tcg); or 2nd order bridge.
7. There are many options for a 6-point calibration; however, the most likely would be for both 1st and 2nd order correction of Tco and Tcg.
8. 7-point calibration would have all three 2nd order terms applied: SOT_tco, SOT_tcg, and SOT_bridge.

Step 3 – Coefficient Calculations

The math to perform the coefficient calculation is complicated and will not be discussed in detail. There is a rough overview in section 3.8. ZMDI provides software (DLLs) to perform the coefficient calculation. After the coefficients are calculated, the final step is to write them to the EEPROM of the ZSC31014.

3.8. Calibration Math

ZMDI can provide software and hardware with samples to perform the calibration. For a complete description and detailed examples, see *ZSC31014_SSC_Evaluation_Kit_Description_Rev_X.xy.pdf*. For more details on the following equations, refer to *ZSC31014 Technical Note—Detailed Equations for ZSC31014 Math* (available on request).



3.8.1. Bridge Signal Compensation

SOT_curve (bit 9 in EEPROM word 01_{HEX}; see section 3.6) selects whether second-order equations compensate for sensor nonlinearity with a parabolic or S-shaped curve.

The correction formula for the differential signal reading is represented as a two-step process depending on the SOT_curve setting.

Note: The following equations are only meant to show the general form and capabilities of the ZSC31014 sensor signal conditioning. Full details of the equations are not given.

Equations for the parabolic SOT_curve setting (SOT_curve = 0):

$$\mathbf{ZB} = \mathbf{Gain_B} [1 + \Delta T(\mathbf{SOT_tcg} * \Delta T + \mathbf{Tcg})] * [\mathbf{BR_Raw} + \mathbf{Offset_B} - \mathbf{ADC_Offset} + \Delta T(\mathbf{SOT_tco} * \Delta T + \mathbf{Tco})] + 2000_{\text{HEX}} \quad (4)$$

$$\mathbf{B} = \mathbf{ZB} * (1 + \mathbf{SOT_bridge} * \mathbf{ZB}) \quad (5)$$

Equations for the S-shaped SOT_curve setting (SOT_curve = 1):

$$\mathbf{ZB} = \mathbf{Gain_B} [1 + \Delta T(\mathbf{SOT_tcg} * \Delta T + \mathbf{Tcg})] * [\mathbf{BR_Raw} + \mathbf{Offset_B} - \mathbf{ADC_Offset} + \Delta T(\mathbf{SOT_tco} * \Delta T + \mathbf{Tco})] \quad (6)$$

$$\mathbf{B} = \mathbf{ZB} * (1 + \mathbf{SOT_bridge} * |\mathbf{ZB}|) + 2000_{\text{HEX}} \quad (7)$$

Where

- B** = Corrected bridge reading output via I²CTM or SPI
- ZB** = Intermediate result in the calculations
- BR_Raw** = Raw bridge reading from ADC after AZ correction
- Gain_B** = Bridge gain term
- Offset_B** = Bridge offset term
- Tcg** = Temperature coefficient gain term
- Tco** = Temperature coefficient offset term
- T_Raw** = Raw temperature reading
- T_{SETL}** = T_Raw reading at which low calibration was performed (typically 25°C)
- ΔT** = (T_Raw - T_{SETL})
- SOT_tcg** = Second-order term for Tcg non-linearity
- SOT_tco** = Second-order term for Tco non-linearity
- SOT_bridge** = Second-order term for bridge non-linearity
- 2000_{HEX}** = Converts result to the unsigned domain
- ADC_Offset** = 2¹⁴ * ratio of the selected A2D_Offset (EEPROM word B_Config)

ZSC31014

RBic_{Lite}TM Digital Output Sensor Signal Conditioner



The Analog Mixed Signal Company



3.8.2. Temperature Signal Compensation

If a compensated temperature output is also required, a temperature calibration is necessary. Temperature correction contains both linear gain and offset terms as well as a second-order term to correct for any non-linearities. For temperature, second-order compensation for nonlinearity is always parabolic.

The following equations are only meant to show the general form and capabilities of the ZSC31014 sensor signal conditioning. Full details of the equations are not given.

Again, the correction formula is best represented as a two-step process as follows:

$$ZT = \text{Gain_T} * [T_Raw + \text{Offset_T}] \quad (8)$$

$$T = ZT * (1 + \text{SOT_T} * ZT) \quad (9)$$

Where:

- Gain_T** = Gain coefficient for temperature
- T_Raw** = Raw temperature reading
- Offset_T** = Offset coefficient for temperature
- SOT_T** = Second-order term for temperature source non-linearity

3.8.3. Limits Imposed on Coefficient Ranges

There are range limits on some of the calibration coefficients that will be enforced by software and DLLs provided by ZMDI. These limits ensure the integrity of the internal calculations and would only limit the most extreme cases of sensor correction. The limits are outlined in Table 3.8.

Table 3.8 Restrictions on Coefficient Ranges

Coefficient	Valid Range	Comment
Gain_B, Gain_T	When Gain8x=0: 2000 to 7FFF When Gain8x=1: 400 to 7FFF	A gain less than unity (attenuating) implies the range of interest is being clipped in the A2D. In this case, a lower PreAmp_Gain should be chosen. Gains greater than 7FFF (≈4.0) can cause overflow in the internal calculations. If digital gains greater than 4.0 are needed for the bridge, use the Gain8x feature.
Offset_B, Offset_T	Positive offset (0 to 1FFF) Negative offset (E000 to FFFF)	Offsets are a signed number that is added to the result of a 14-bit A2D conversion. Although the EEPROM register is 16-bits wide, the coefficient cannot exceed the range of a signed 14-bit number.
SOT_B, SOT_T	Positive SOT (0 to 7FFF) Negative SOT (0 to 3FF)	Positive SOTs greater than 7FFF can cause overflow in the internal math. Negative SOTs greater in magnitude than 3FF are invalid because the function becomes double definite.

ZSC31014

RBic_{Lite}TM Digital Output Sensor Signal Conditioner

ZMDI[®]

The Analog Mixed Signal Company



3.8.4. Interpretation of Binary Numbers for Correction Coefficients

BR_Raw should be interpreted as a signed number in the set [-8192,8191] with a resolution of 1 when the Offset Mode is [-1/2..1/2].

T_Raw should be interpreted as an unsigned number in the set [0,16383] with a resolution of 1.

3.8.4.1. Gain_B and Gain_T Interpretation

Gain_B and **Gain_T** should be interpreted as a number in the set [0,4). 2000_{HEX} represents unity. Bit 14 has a weight of 2, and each subsequent bit has a weighting of ½ the previous bit. Bit 15 scales **Gain_B** or **Gain_T** by an additional factor of 8. This allows **Gain_B** or **Gain_T** to be a number in the range [0,32).

Table 3.9 Gain_B Weightings

Bit Position	Weighting
15	Gain8x
14	2
13	1
12	2 ⁻¹
.	
.	
1	2 ⁻¹²
0	2 ⁻¹³

Examples:

The binary number: 0100 1010 0110 0010 = 2.3245

The binary number: 1101 1000 1001 0110 = 22.146

ZSC31014

RBic_{Lite}TM Digital Output Sensor Signal Conditioner

ZMDI[®]

The Analog Mixed Signal Company



3.8.4.2. Offset_B and Offset_T Interpretation

Offset_B and Offset_T are 16-bit signed binary numbers in two's complement form. The MSB has a weighting of -32768. The following bits then have a weighting of: 16384, 8192, 4096 ...

Table 3.10 Offset_B Weightings

Bit Position	Weighting
15	-32768
14	16384
13	8192
...	
1	$2^1 = 2$
0	$2^0 = 1$

For example, the binary number 1111 1111 1111 1100 = -4.

3.8.4.3. Tco Interpretation

Tco is specified as having a 16-bit magnitude with its sign determined by TC_Sign (bits [11:10] of EEPROM word 01_{HEX}; see section 3.6).

3.8.4.4. Tcg Interpretation

Tcg is specified as having a 16-bit magnitude with its sign determined by TC_Sign (bits [11:10] of EEPROM word 01_{HEX}; see section 3.6).

3.8.4.5. SOT_tco, SOT_tcg, SOT_bridge, and SOT_T Interpretation

All SOT_terms are specified as having a 16-bit magnitude with the sign determined by SOT_Sign (bits [15:12] of EEPROM word 01_{HEX}; see section 3.6).

SOT_curve selects parabolic or S-shaped fit for the bridge compensation. For temperature compensation, parabolic is always used.

ZSC31014

RBic_{Lite}TM Digital Output Sensor Signal Conditioner



4 Application Circuit Examples

The digital output of the ZSC31014 can be read via I²CTM or SPI. The ZSC31014 can be configured in Sleep or Update Mode for the Normal Operation Mode, which outputs the corrected measurement readings. The B_Config settings for Gain_Polarity, PreAmp_Gain and A2D_Offset are given only as examples because these values must be adapted specifically to the sensor signal range.

4.1. I²CTM Interface – Bridge using Low Power Bsink Option

This example demonstrates the low power Bsink option with internal temperature sensing. Data is output via the I²CTM interface. For this application, V_{DD} is assumed to be 5V and the bridge sensor voltage is 16.5mV to 61.5mV. In this case, the B_Config register setting for PreAmp_Gain is 24, which means nulling should be on, and the A2D_Offset is ½ to - ½. Update Mode with a slower update rate and Bsink are enabled to save power.

For temperature correction, use the T_Config settings that are pre-programmed in production test. (See the T_Config defaults in Table 3.7.)

NOTE: The A2D_Offset and PreAmp_Gain terms in T_Config are programmed during test to avoid saturation of the internal temperature bridge. Do not change these parameters (designated with † in Table 4.1).

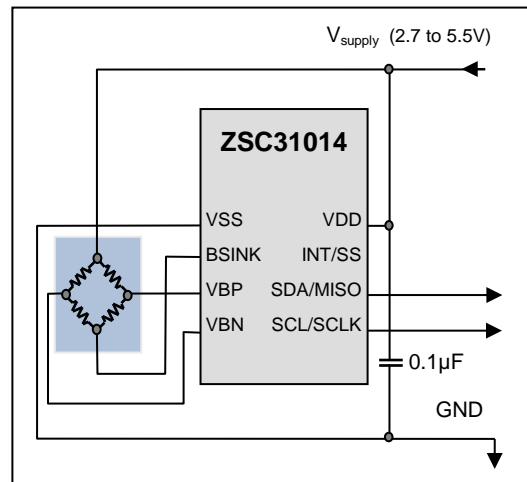

Figure 4.1 Example 1 Circuit Diagram: Bsink Option and Internal Temperature Correction and I²CTM Output

Table 4.1 Register Settings—Example 1

	Reserved [15:13]			Disable Nulling [12]	PreAmp_Mux [11:10]		Bsink[9]	Longint[8]	Gain_Polarity[7]	PreAmp_Gain [6:4]			A2D_Offset [3:0]			
B_Config 0F _{HEX}	0	0	0	0	1	0	1	0	1	0	1	0	1	0	0	0
T_Config 10 _{HEX}	0	0	0	0	0	1	0 [†]	0	1	0 [†]	0 [†]	1 [†]	†	†	†	†

† Reserved setting – do not change factory settings. If factory trim settings have been lost, program T_Config to 149_{HEX}.

ZSC31014

RBic_{Lite}TM Digital Output Sensor Signal Conditioner



The Analog Mixed Signal Company



4.2. Generic Differential A2D Converter

The ZSC31014 has many PreAmp_Gain settings available and makes an excellent 14-bit analog-to-digital converter with I²CTM or SPI output for any differential signal source. In this application, the ZSC31014 is being used as a generic differential A2D converter. The PreAmp_Mux bit in B_Config must be set to 10. The PreAmp_Gain is set to 24, which means nulling should be on, and the A2D_Offset is set to -1/2, 1/2 in this example.

For temperature correction, use the T_Config settings that are pre-programmed in production test. (See the T_Config defaults in Table 3.7.)

NOTE: The A2D_Offset and PreAmp_Gain terms in T_Config are programmed during test to avoid saturation of the internal temperature bridge. Do not change these parameters (designated with † in Table 4.2).

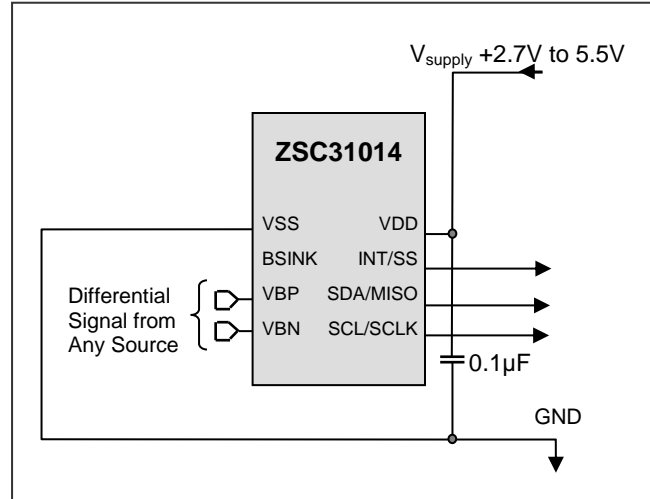

Figure 4.2 Example 2 Circuit Diagram: Generic Differential A2D Converter

Table 4.2 Register Settings—Example 2

	Reserved [15:13]				Disable Nulling [12]	PreAmp_Mux [11:10]		Bsink[9]	Longint[8]	Gain_Polarity[7]	PreAmp_Gain[6:4]			A2D_Offset [3:0]			
B_Config 0F _{HEX}	0	0	0	0	0	1	0	0	0	1	0	1	0	1	0	0	0
T_Config 10 _{HEX}	0	0	0	0	0	0	1	0 [†]	0	1	0 [†]	0 [†]	1 [†]	†	†	†	†

† Reserved setting – do not change factory settings. If factory trim settings have been lost, program T_Config to 149_{HEX}.

ZSC31014

RBic_{Lite}TM Digital Output Sensor Signal Conditioner



The Analog Mixed Signal Company



4.3. Half-Bridge Measurement

In this application, the ZSC31014 is being used as a signal conditioner for a half-bridge signal from a Honeywell HIH4000 humidity sensor. This application shows the option of measuring a single voltage (1V to 3.8V) and using the internal temperature sensor for temperature correction.

VBN is internally connected to a voltage divider as a reference ($V_{DD}/2$). In this case, the PreAmp_Mux bit in B_Config must be 11 and the PreAmp_Gain must be set to the lowest value (1.5), which means nulling should be off.

For temperature correction, use the T_Config settings that are pre-programmed in production test. (See the T_Config defaults in Table 3.7.)

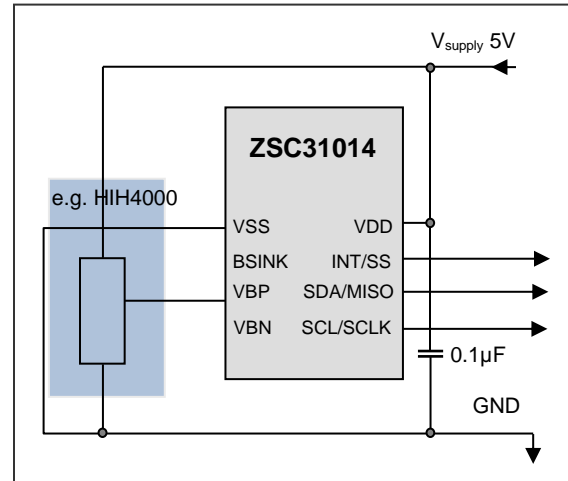

Figure 4.3 Half-Bridge Voltage Measurement with Internal Temperature Correction

NOTE: The A2D_Offset and PreAmp_Gain terms in T_Config are programmed during test to avoid saturation of the internal temperature bridge. Do not change these parameters (designated with † in Table 4.3).

Table 4.3 Register Settings—Example 3

	Reserved [15:13]			Disable Nulling [12]	PreAmp_Mux [11:10]			Bsink[9]	Longint[8]	Gain_Polarity[7]	PreAmp_Gain[6:4]			A2D_Offset [3:0]		
B_Config 0F _{HEX}	0	0	0	1	1	1	0	0	1	0	0	0	0	0	1	0
T_Config 10 _{HEX}	0	0	0	0	0	1	0 [†]	0	1	0 [†]	0 [†]	1 [†]	†	†	†	†

† Reserved setting – do not change factory settings. If factory trim settings have been lost, program T_Config to 149_{HEX}.

ZSC31014

RBic_{Lite}TM Digital Output Sensor Signal Conditioner

ZMDI[®]

The Analog Mixed Signal Company



5 ESD/Latch-Up-Protection

All pins have an ESD protection of >4000V and a latch-up protection of $\pm 100\text{mA}$ or (up to +8V / down to -4V) relative to VSS/VSSA. ESD protection referenced to the Human Body Model is tested with devices in SOP-8 packages during product qualification. The ESD test follows the Human Body Model with 1.5kOhm/100pF based on MIL 883, Method 3015.7.

6 Pin Configuration and Package

The standard package of the ZSC31014 is SOP-8 (3.81mm body (150mil) wide) with lead-pitch 1.27mm (50mil). See the notes in Table 6.2 regarding connection requirements.

Table 6.1 Storage and Soldering Conditions for the SOP-8 Package

Parameter	Symbol	Conditions	Min	Typ	Max	Unit
Maximum Storage Temperature	T _{max_storage}	Less than 10hrs, before mounting			150	°C
Minimum Storage Temperature:	T _{min_storage}	Store in original packing only	-50			°C
Maximum Dry-Bake Temperature	T _{drybake}	Less than 100 hrs total, before mounting			125	°C
Soldering Peak Temperature	T _{peak}	Less than 30s (IPC/JEDEC-STD-020 Standard)			260	°C

ZSC31014

RBic_{Lite}TM Digital Output Sensor Signal Conditioner

ZMDI[®]

The Analog Mixed Signal Company



Figure 6.1 ZSC31014 Pin-Out Diagram

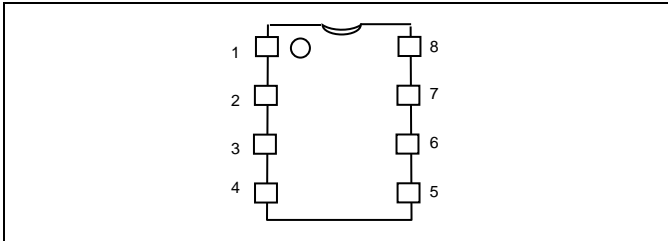

Table 6.2 ZSC31014 Pin Assignments

Pin No.	Name	Description	Note
1	VSS	Ground supply.	Must connect to GND.
2	Bsink	Switched ground for bridge sink – optional feature for power savings.	If not used, must be unconnected.
3	VBP	Positive input for differential signal (bridge positive).	
4	VBN	Negative input for differential signal (bridge negative).	
5	SCL/SCLK	I ² C TM clock if in I ² C TM Mode. Serial clock if in SPI Mode.	
6	SDA/MISO	I ² C TM data if in I ² C TM Mode. Master-In-Slave-Out if in SPI Mode.	
7	INT/SS	Interrupt signal (conversion complete output) if in I ² C TM Mode. Slave Select (input) if in SPI Mode.	If not used, must be unconnected.
8	VDD	Supply voltage (2.7-5.5V).	Must connect to Vsupply.

7 Test

The test program is based on this datasheet. The final parameters, which will be tested during production, are listed in the tables of section 1.

The digital part of the IC includes a scan path, which can be activated and controlled during wafer test. It guarantees failure coverage of more than 80%. Additional digital and analog tests are added to increase this coverage to over 90%. See test specification for further details.

8 Reliability

A reliability investigation according to the in-house non-automotive standard has been performed.

ZSC31014

RBic_{Lite}TM Digital Output Sensor Signal Conditioner

ZMDI[®]

The Analog Mixed Signal Company



9 Customization

For high-volume applications that require upgraded or downgraded functionality compared to the ZSC31014, ZMDI can customize the circuit design by adding or removing certain functional blocks. For this customization, ZMDI has a considerable library of sensor-dedicated circuitry blocks, which enable ZMDI to provide a custom solution quickly. Please contact ZMDI for further information.

10 Ordering Codes

Sales Code	Description	Package
ZSC31014EAB	ZSC31014 Die — Temperature range: -40°C to +125°C	Unsawn on Wafer
ZSC31014EAC	ZSC31014 Die — Temperature range: -40°C to +125°C	Sawn on Wafer Frame
ZSC31014EAG1	ZSC31014 SOP8 (150 mil) — Temperature range: -40° to +125°C	Tube: add "-T" to sales code Reel: add "-R"
ZSC31014EIB	ZSC31014 Die — Temperature range: -40° to +85°C	Unsawn on Wafer
ZSC31014EIC	ZSC31014 Die — Temperature range: -40° to +85°C	Sawn on Wafer Frame
ZSC31014EIG1	ZSC31014 SOP8 (150 mil) — Temperature range: -40° to +85°C	Tube: add "-T" to sales code Reel: add "-R"
ZSC31014KIT	ZSC31014 SSC Evaluation Kit: Communication Board, SSC Board, Sensor Replacement Board, USB Cable, and 5 IC Samples (software can downloaded on the ZSC31014 product page at www.zmdi.com/zsc31014)	Kit

Contact ZMDI Sales for support and sales of ZMDI's ZSC31014 Mass Calibration System.

11 Related Documents

Note: X.xy refers to the most recent version.

Document	File Name
ZSC31014 SSC Evaluation Kit Description	ZSC31014_SSC_Evaluation_Kit_Description_Rev_X.xy.pdf
ZSC31014 SSC Mass Calibration System Description *	ZSC31014_SSC_Mass_Calibration_Rev_X.xy.pdf
ZSC31014 Technical Notes—Calibration Sequence and Calibration DLL *	ZSC31014_TN_Calibration_DLL_Rev_X.xy.pdf
ZSC31014 Technical Note—Detailed Equations for Calibration Math **	ZSC31014_TN_Calibration_Math_Rev_X.xy.pdf
ZMDI Technical Note—Wafer Dicing Guidelines	ZMDI_Wafer_Dicing_Guidelines_Rev_X.xy.pdf

For the most recent revision of this document and of the related documents, visit the ZSC31014 product page at www.zmdi.com/zsc31014 on ZMDI's website at www.zmdi.com or contact your nearest ZMDI sales office.

* Documents marked with an asterisk (*) require a login account for access on the web. For detailed instructions, visit www.zmdi.com/login-account-setup-procedure.

** Documents marked with a double asterisk (**) are available only on request (see page 59 for contact information).

Data Sheet July 2, 2014.	© 2014 Zentrum Mikroelektronik Dresden AG — Rev. 1.64 All rights reserved. The material contained herein may not be reproduced, adapted, merged, translated, stored, or used without the prior written consent of the copyright owner. The information furnished in this publication is subject to changes without notice.	57 of 59
-----------------------------	---	----------

ZSC31014

RBiC_{Lite}TM Digital Output Sensor Signal Conditioner

ZMDI[®]

The Analog Mixed Signal Company



12 Definitions of Acronyms

Term	Description
ADC	Analog-to-Digital Converter
AFE	Analog Front-End
ACK	Acknowledge
MCU	Microprocessor
MSB	Most Significant Bit
NACK	Not Acknowledged
SCL	Serial Clock
SDA	Serial Data
SPI	System Packet Interface

13 Document Revision History

Revision	Date	Description
1.20	May 15, 2009	Added notation for timing tolerance (nominal frequency $\pm 15\%$) in section 3. Table 2.4 A2D_Offset Signals. Added all possible configurations. Revised web address and sales contacts.
1.30	January 20, 2010	Revisions to EEPROM default values in Table 3.7. Addition of ordering information.
1.32	April 5, 2010	Clarification of ordering information. Correction of values in Table 1.4. Default values for Osc_trim changed. Changed Equations (4) and (6).
1.33	May 6, 2010	Added EEPROM specifications to section 1.3 "Electrical Parameters." Added Table 6.1 "Storage and Soldering Conditions" to section 6 "Pin Configuration and Package." Added notes to Table 6.2 "ZSC31014 Pin Assignments." Matched A2D_Offset settings in Table 3.7 for B_Config and T_Config to Table 2.4.
1.34	July 21, 2010	Clarification of external temperature measurement, section 2.2.3.2. Addition of DF4 to Figure 3.6.
1.40	July 27, 2010	Revision of product name from ZMD31014 to ZSC31014.
1.50	January 7, 2011	Added I ² C TM specification deviation note, section 2.3.4
1.51	March 13, 2011	Update to ZMDI contact information.
1.52	July 12, 2011	Addition of Offset_B column to Table 2.4 for coefficient settings needed when collecting uncalibrated raw bridge values from the ADC.
1.53	May 10, 2012	Update to part ordering code table in section 10. Update to contact information. Revision of product title.
1.60	September 21, 2012	Revision of "Power-On-Reset Level" specification in section 1.3 and related text in section 2.3.6. Update for product ordering codes.
1.61	December 6, 2012	Update for contact information for Zentrum Mikroelektronik Dresden AG Korea Office and phone numbers for USA office.

ZSC31014

RBic_{Lite}TM Digital Output Sensor Signal Conditioner



The Analog Mixed Signal Company



Revision	Date	Description
1.62	March 11, 2013	Removed external temperature compensation. Updates for part order codes in section 10. Updates for contact information and minor edits to cover and header imagery.
1.63	April 21, 2014	Revision of "I ² C TM Interface & SPI Interface" section of Table 1.3. Minor updates for references to product and contents of Evaluation Kit. Waffle pack is no longer an option for delivery package. Updates for contact information.
1.64	July 2, 2014	Revision of calibration temperature for SOP8-packaged parts in section 2.2.3 and related default entries for registers 0A _{HEX} to 0D _{HEX} in Table 3.7. Update for section 8 regarding quality testing. Updates for contact information.

Sales and Further Information		www.zmdi.com	SSC@zmdi.com
Zentrum Mikroelektronik Dresden AG Global Headquarters Grenzstrasse 28 01109 Dresden, Germany Central Office: Phone: +49.351.8822.306 Fax: +49.351.8822.337	ZMD America, Inc. 1525 McCarthy Blvd., #212 Milpitas, CA 95035-7453 USA USA Phone 1.855.275.9634 Phone +1.408.883.6310 Fax +1.408.883.6358	Zentrum Mikroelektronik Dresden AG, Japan Office 2nd Floor, Shinbashi Tokyu Bldg. 4-21-3, Shinbashi, Minato-ku Tokyo, 105-0004 Japan Phone +81.3.6895.7410 Fax +81.3.6895.7301	ZMD FAR EAST, Ltd. 3F, No. 51, Sec. 2, Keelung Road 11052 Taipei Taiwan Phone +886.2.2377.8189 Fax +886.2.2377.8199
Zentrum Mikroelektronik Dresden AG, Korea Office U-space 1 Building 11th Floor, Unit JA-1102 670 Sampyeong-dong Bundang-gu, Seongnam-si Gyeonggi-do, 463-400 Korea Phone +82.31.950.7679 Fax +82.504.841.3026	European Technical Support Phone +49.351.8822.7.772 Fax +49.351.8822.87.772 European Sales (Stuttgart) Phone +49.711.674517.55 Fax +49.711.674517.87955		
DISCLAIMER: This information applies to a product under development. Its characteristics and specifications are subject to change without notice. Zentrum Mikroelektronik Dresden AG (ZMD AG) assumes no obligation regarding future manufacture unless otherwise agreed to in writing. The information furnished hereby is believed to be true and accurate. However, under no circumstances shall ZMD AG be liable to any customer, licensee, or any other third party for any special, indirect, incidental, or consequential damages of any kind or nature whatsoever arising out of or in any way related to the furnishing, performance, or use of this technical data. ZMD AG hereby expressly disclaims any liability of ZMD AG to any customer, licensee or any other third party, and any such customer, licensee and any other third party hereby waives any liability of ZMD AG for any damages in connection with or arising out of the furnishing, performance or use of this technical data, whether based on contract, warranty, tort (including negligence), strict liability, or otherwise.			

Data Sheet July 2, 2014.	© 2014 Zentrum Mikroelektronik Dresden AG — Rev. 1.64 All rights reserved. The material contained herein may not be reproduced, adapted, merged, translated, stored, or used without the prior written consent of the copyright owner. The information furnished in this publication is subject to changes without notice.	59 of 59
------------------------------------	---	----------

Mouser Electronics

Authorized Distributor

Click to View Pricing, Inventory, Delivery & Lifecycle Information:

[ZMDI:](#)

[ZSC31014DAG1-R](#) [ZSC31014DAG1-T](#) [ZSC31014DIG1-R](#) [ZSC31014DIG1-T](#) [ZSC31014EAG1-T](#) [ZSC31014EIG1-T](#)
[ZSC31014EAG1-R](#) [ZSC31014EIG1-R](#) [ZSC31014 V1.1](#)