

ISL8216MEVAL1Z Evaluation Board User's Guide

Description

The ISL8216M is a simple and easy to use, high voltage DC/DC module. The ISL8216M is ideal for servers, 48V telecom/datacom applications, 12V/42V automotive and industrial equipment, and other distributed power converters/point-of-load (POL) applications. Only few passive components and a V_{OUT} setting resistor are needed for a complete a high voltage power design.

The ISL8216MEVAL1Z provides an evaluation platform for the ISL8216M. The input voltage range is from 10V to 80V, and the output voltage is preset to five options, 5V, 12V, 20V, 24V and 30V. Any other output voltages within the range from 2.5V to 30V can be set with a single resistor.

Recommended Equipment

- 10V to 80V (or other voltage rating depending on desired input voltage for the ISL8216M) power supply with at least 2A source current capability
- Electronic load capable of sinking current up to 4A
- Digital multimeters (DMMs)
- 100MHz quad-trace oscilloscope

Quick Start

1. Select the output voltage by using one of the five jumpers JP1 to JP5, for 5V, 12V, 20V, 24V or 30V.
2. Connect the VIN (J1) and PGND (J2) terminals to a power supply and connect the load to the VOUT (J4) and PGND (J3) terminals.
3. Set the input power supply to desired input voltage between 10V to 80V; note that the input voltage must be higher than the selected output voltage.
4. Enable the power supply first before turning on the load, preset the load to 0A.
5. Toggle switch SW1 to the lower position denoted "ENABLE". The PGOOD INDICATOR LED should glow in green to indicate proper operation. Use the digital multimeter to check the output voltage.

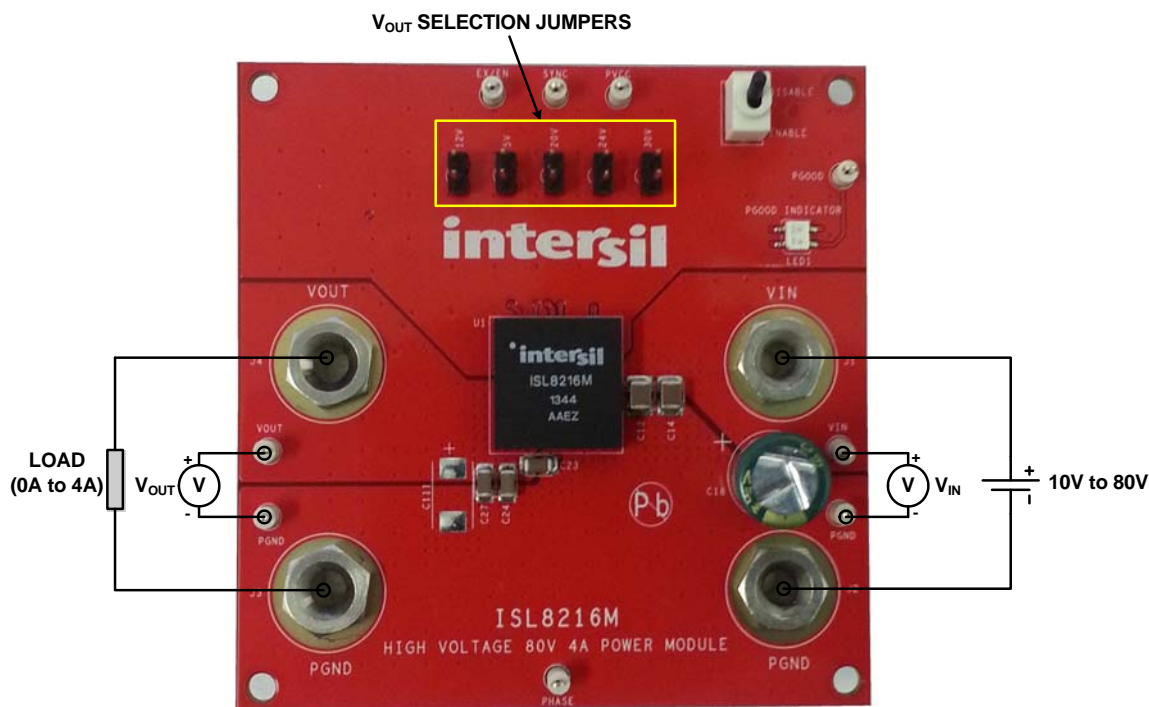

FIGURE 1. ISL8216MEVAL1Z BOARD IMAGE

Evaluation Board Information

The evaluation board size is 76.2mmx76.2mm (3 inchx3 inch). The FR4 board has four layers, with 2oz copper on the top and the bottom layers, and 1oz copper on the two internal layers. The board can be used as 4A reference design. Refer to the “ISL8216MEVAL1Z Board Schematic” on page 4 and “ISL8216MEVAL1Z Layouts” on page 5. All the components on the board, including the solder attachment, are lead free.

Circuits Description

Selecting Output Voltage

The ISL8216MEVAL1Z evaluation board has several output voltages preset for user’s convenience. The 5V, 12V, 20V, 24V, and 30V can be easily selected by shorting their appropriate jumper. If any other output voltage between 2.5V and 30V is desired, the user can use a feedback resistor based on Equation 1.

$$V_{OUT} = \left(1 + \frac{11.3k\Omega}{R_{FB}}\right) \cdot 1.192V \quad (EQ. 1)$$

NOTE: The output voltage accuracy is not only dependent on the module’s internal reference voltage, but also on the feedback resistance accuracy. For higher overall output accuracy, the customer should select a high accuracy resistor (i.e; 0.5%).

Programming the Switching Frequency

The ISL8216M has an internally set fixed switching frequency of 300kHz. By adding a resistor between V_{IN} and RTCT and a capacitor between RTCT and SGND, the module’s switching frequency can be adjusted between 200kHz to 600kHz. The place holders for the resistor (R5) and capacitor (C5) are provided on the ISL8216MEVAL1Z evaluation board for the user’s convenience. Refer to the [ISL8216M](#) datasheet for optimum switching frequency for different conditions.

The SYNC pin can provide the function to synchronize the ISL8216M’s switching frequency to an external source. When frequency synchronization is used, the time constant of R_T/C_T must be set longer than the period of the sync signal. When the external sync feature is not used, the customer should tie the SYNC pin to SGND.

Optional External Enable Control Circuit

The module can be enabled by an external signal by using an open-drain device, or by adding an external circuit. This optional

external enable circuit is provided on the ISL8216MEVAL1Z evaluation board, see Figure 2.

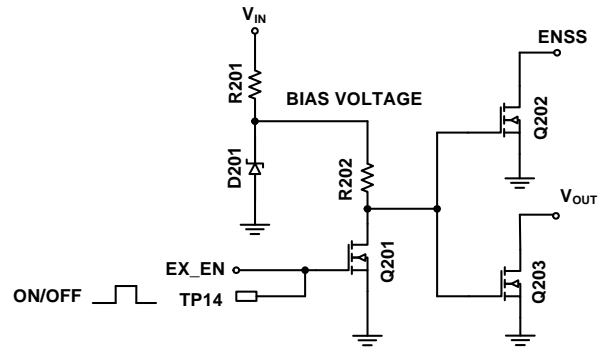

FIGURE 2. OPTIONAL EXTERNAL ENABLE CIRCUIT

To utilize the circuit shown in Figure 2, the user can place appropriate components on the place holders for R201, D201, R202, Q201, and Q202.

A bias voltage of approximately 5.1V is generated from V_{IN} with a resistor (R201) in series and a zener diode (D201). R202 is a pull-up resistor of typically 100kΩ, and Q201 and Q202 are N-MOSFETs. The external control signal is applied to TP14 (EX_EN). When EX_EN is logic low, ENSS is pulled to ground to disable the module. When EX_EN is logic high, ENSS is released to allow the module’s soft-start function. The selection of R201 in series with the zener diode D201 can be calculated as shown in Equation 2:

$$R201 = \frac{V_{IN} - V_Z}{I_Z} \quad (EQ. 2)$$

Where:

- V_Z is the zener diode D201’s working voltage, nominal 5.1V.
- I_Z is the zener diode D201’s working reverse current, typically about 5mA.

The power dissipation rating should be taken into consideration when selecting R201.

Other External Circuits Requirements

Depending on the applications conditions, other external circuits may be required. Table 1 shows these requirements.

TABLE 1. EXTERNAL CIRCUITS REQUIREMENT BASED ON APPLICATION CONDITIONS

CONDITIONS			EXTERNAL CIRCUITS REQUIREMENTS		
V_{OUT}	Use PGOOD Signal	Enable Method	PGOOD Delay Circuit	1kΩ Dummy Load Resistor	V_{IN} -BOOT Resistor
≤12V	Yes/No	Self or External Enable Control	No	No	No
>12V	Yes	Self Enable	Yes	Yes	No
>12V	No	Self Enable	No	No	Yes
>12V	Yes	External Enable Control	No	No	Yes
>12V	No	External Enable Control	No	No	Yes

Optional PGOOD Delay Circuit

The ISL8216M has a PGOOD comparator which monitors the voltage on the FB pin. The PGOOD is asserted (open drain) when the FB pin voltage is within 14% of the reference voltage. The PGOOD is de-asserted under disable, overcurrent protection event, or over-temperature event.

As described in Table 1, a PGOOD delay circuit, as well as a dummy load resistor of 1k Ω , 1W rating, are required if all of the following conditions are met:

- V_{OUT} is higher than 12V
- PGOOD signal is utilized
- Module is self enabled/disabled

The place holders for this PGOOD delay circuit (C2, R3 and M1) and the dummy load resistor (R20) are provided on the ISL8216MEVAL1Z evaluation board for the user's convenience, as shown in Figure 3, where C2 is 1 μ F, R3 is typically 150k Ω , and M1 is an N-MOSFET. In the case where input voltage V_{IN} is not monotonic, an optional Schottky diode is recommended in parallel with resistor R3, to ensure that the capacitor C2 has been fully discharged when PVCC starts to rise from 0V.

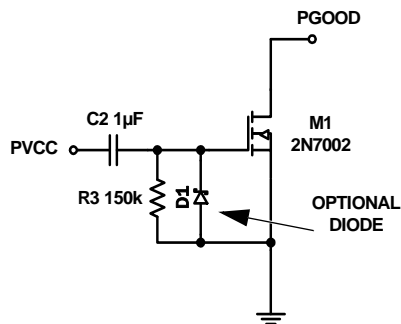

FIGURE 3. OPTIONAL PGOOD DELAY CIRCUIT WITH DIODE

For $V_{OUT} > 12V$ and light load condition, if the optional PGOOD delay circuit is not used during V_{IN} ramp up, PGOOD logic can malfunction due to low V_{OUT} as a result of bootstrap capacitor not being fully charged. This issue can be solved by adding a delay of about 250ms with this optional delay circuit.

Resistor Between V_{IN} and BOOT

As described in Table 1, a resistor between V_{IN} and BOOT is recommended if ANY of the following conditions are met:

- V_{OUT} is higher than 12V and PGOOD signal is not utilized.
- V_{OUT} is higher than 12V, PGOOD signal is utilized, and module is enabled/disabled by an external control signal.

The place holder for this resistor, R23, is provided on the ISL8216MEVAL1Z evaluation board for the user's convenience. Refer to the [ISL8216M](#) datasheet for the selection of this resistor. A minimum 0.25W power rating is recommended for this resistor.

An additional N-MOSFET along with the external enable circuit is required when R23 is populated. This N-MOSFET is used for pulling V_{OUT} to ground when the external control signal is logic low. Without this N-MOSFET, a residual voltage can be generated

on V_{OUT} capacitors due to leakage from V_{IN} , R23, internal bootstrap diode, internal bootstrap capacitor, and inductor to V_{OUT} capacitor.

Output Capacitors

The 6x22 μ F ceramic capacitors with voltage rating of 35V have been installed on the ISL8216MEVAL1Z evaluation board. However, additional place holder to add more capacitors are provided on the board for evaluating low ESR tantalum capacitor, low ESR polymer capacitor, and low ESR aluminum electrolytic capacitor. A minimum total output capacitance of 120 μ F with low ESR is recommended.

PCOMPX Pin Configuration

Control loop is already compensated internally to provide sufficient stability margins for applications with various types of output capacitors. For all ceramic output capacitors, short the PCOMPX pin to V_{OUT} ; a 0 Ω resistor R1 is provided on the evaluation board. For tantalum capacitors, polymer capacitors, or aluminum electrolytic capacitors, change R1 to resistance of lower than 1k Ω . The lower the total ESR, the lower the R1 value should be.

Radiated Emission

The ISL8216M has been evaluated with respect to CISPR 22 radio disturbance limits class B. The radiated emission test was performed with a simple input filter installed on the ISL8216MEVAL1Z evaluation board, as shown in Figure 3. Figure 15 and Figure 16 show the radiated emissions plots with respect to the CISPR 22 radio disturbance limits class B at typical operating conditions of 24V V_{IN} to 5V V_{OUT} at 4A and 24V V_{IN} to 12V V_{OUT} at 4A.

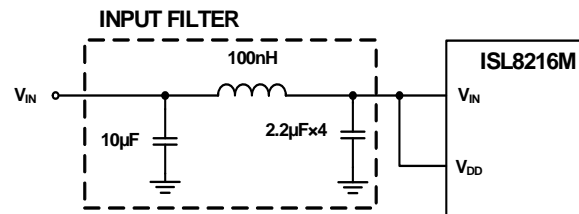

FIGURE 4. OPTIONAL INPUT FILTER FOR IMPROVED EMI PERFORMANCE

ISL8216MEVAL1Z Board Schematic

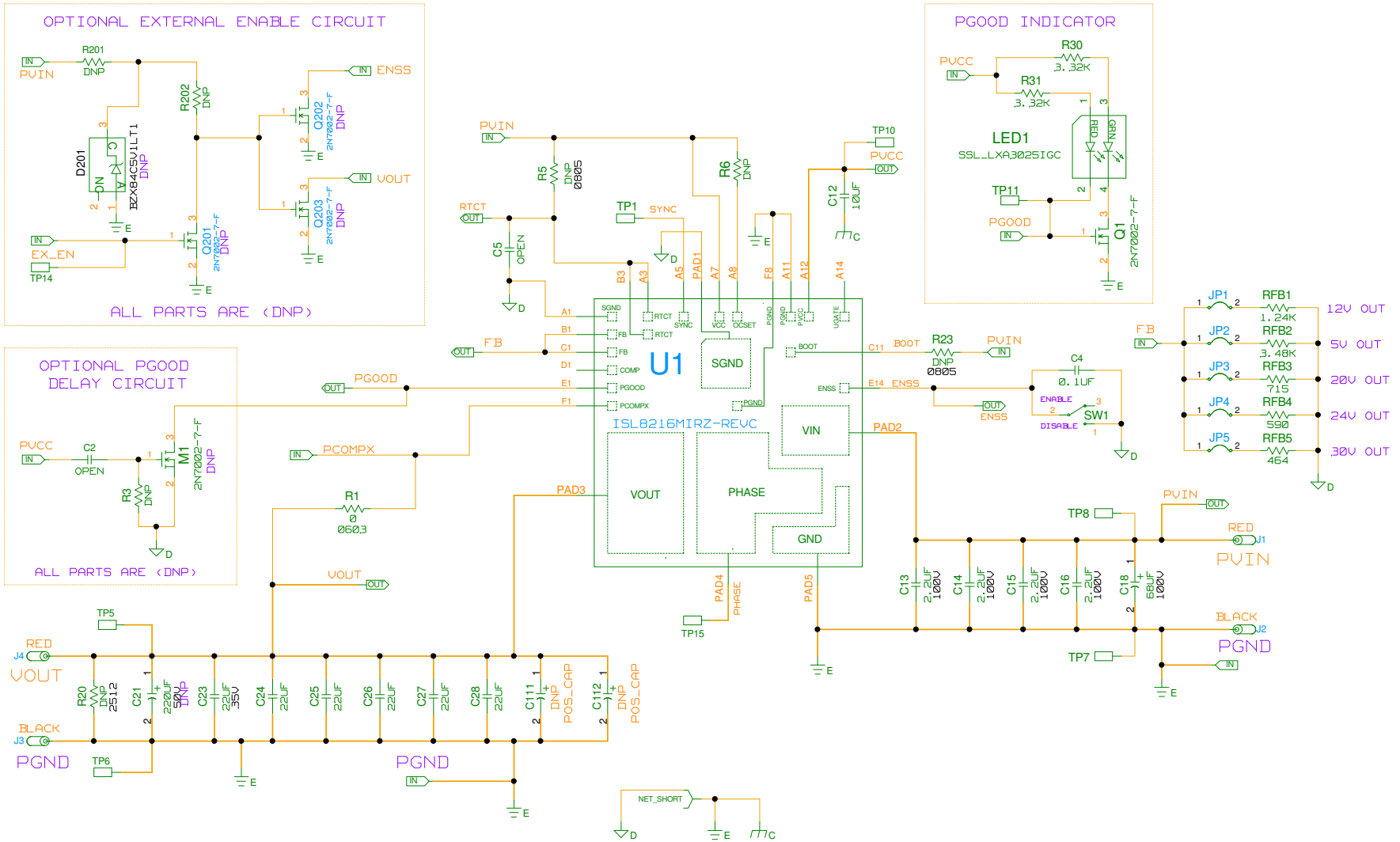

FIGURE 5. ISL8216MEVAL1Z BOARD SCHEMATIC

ISL8216MEVAL1Z Layouts

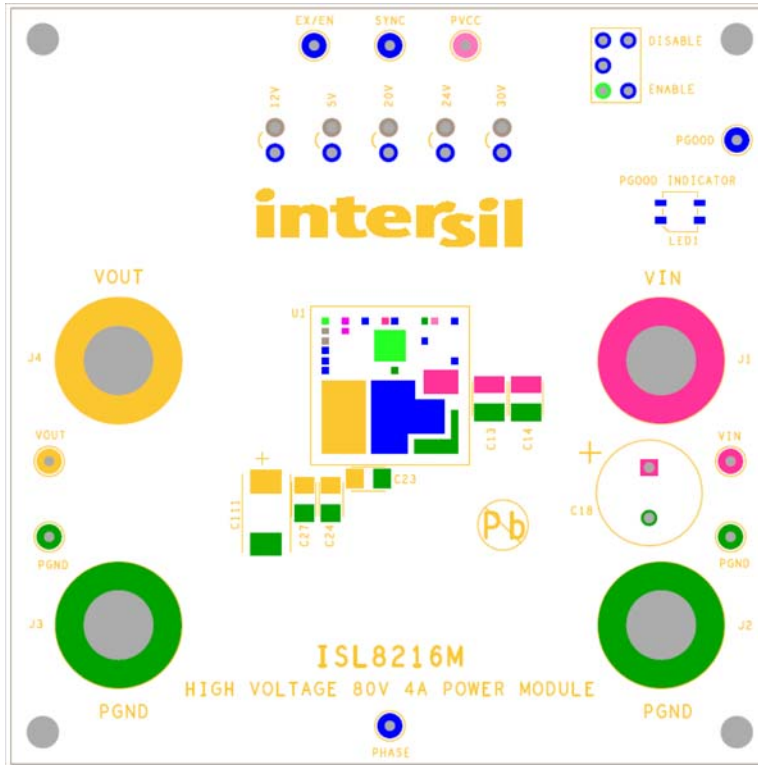

FIGURE 6. TOP SILK SCREEN

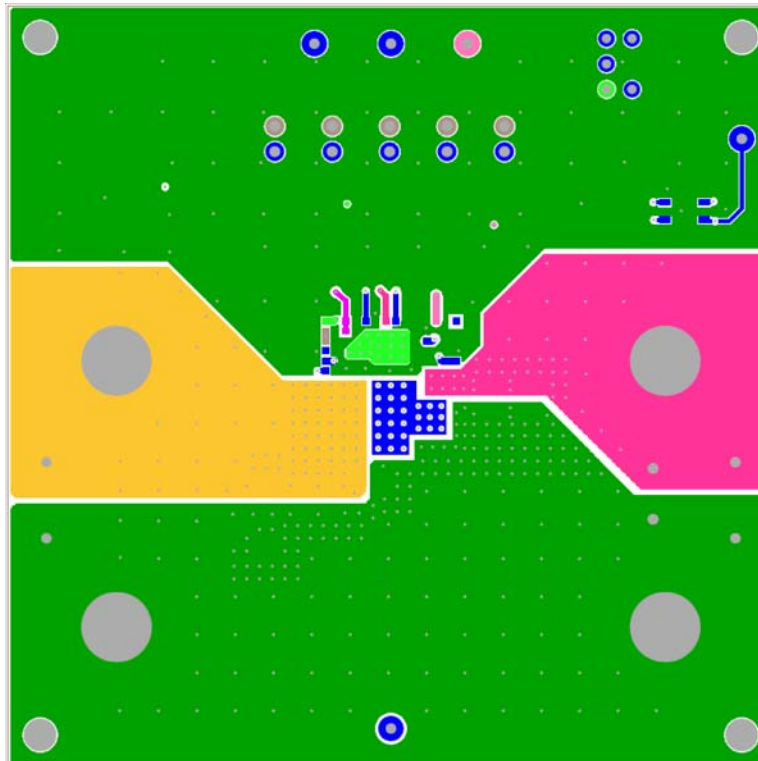

FIGURE 7. TOP LAYER COMPONENT SIDE

ISL8216MEVAL1Z Layouts (Continued)

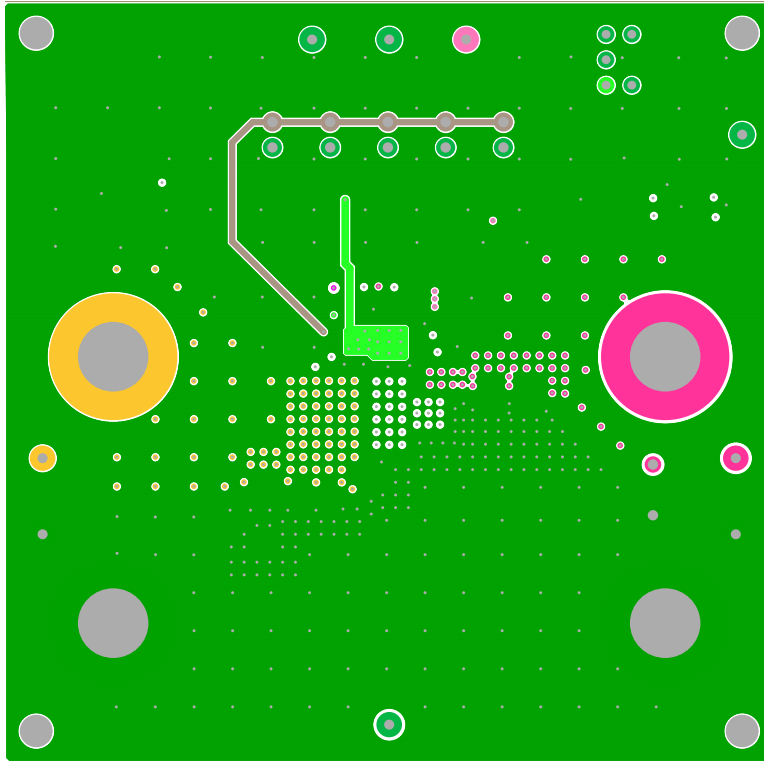

FIGURE 8. LAYER 2

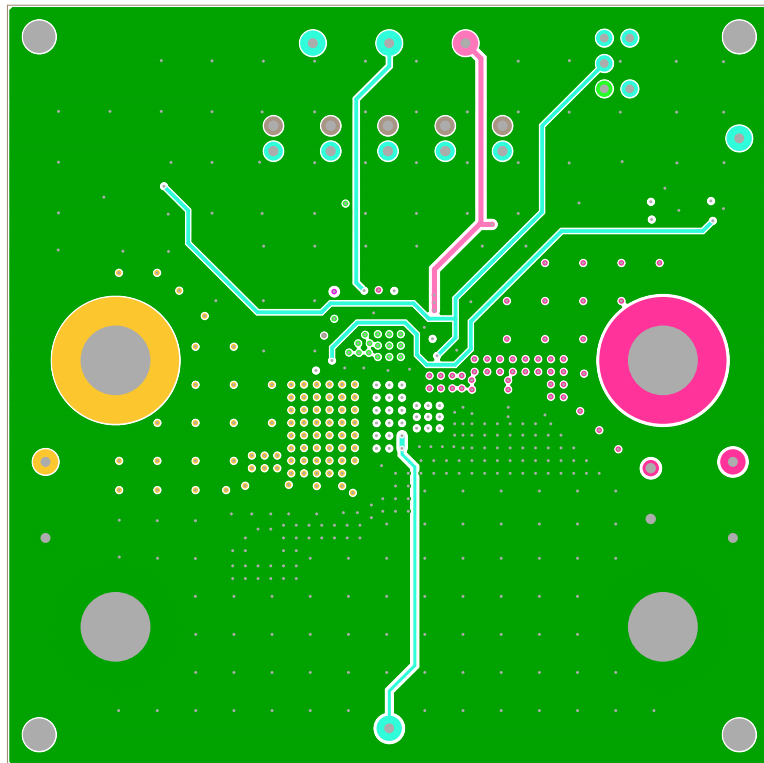

FIGURE 9. LAYER 3

ISL8216MEVAL1Z Layouts (Continued)

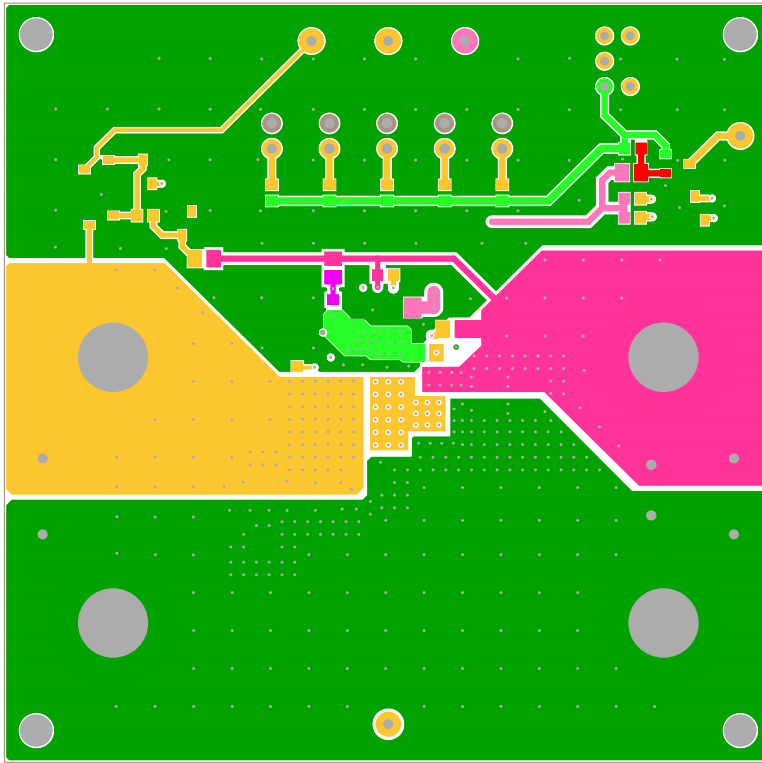

FIGURE 10. BOTTOM LAYER SOLDER SIDE

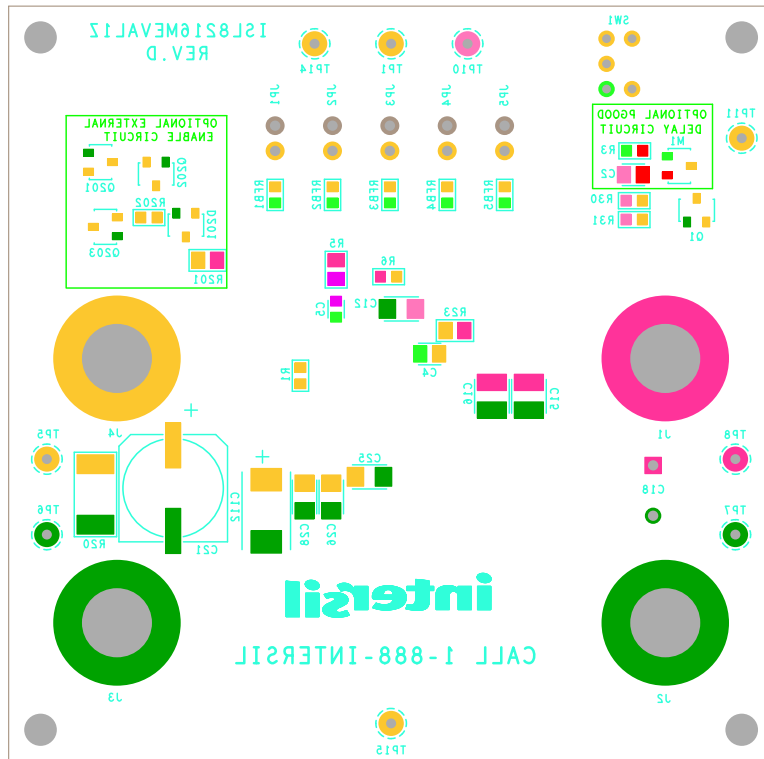

FIGURE 11. BOTTOM SILK SCREEN

Bill of Materials

PART NUMBER	REF DES	QTY	VALUE	TOL.	VOLTAGE	POWER	PACKAGE TYPE	MANUFACTURER	DESCRIPTION
H1046-00104-50V10-T	C4	1	0.1 μ F	10%	50V		805	Various	Multilayer Ceramic Capacitor
H1065-00106-25V10-T	C12	1	10 μ F	10%	25V		1206	Various	
H1082-00225-100V10-T	C13-C16	4	2.2 μ F	10%	100V		1210	Various	
100ME68AX	C18	2	68 μ F	20%	100V		THOLE	Sun Electronic Industries	Aluminum Electrolytic Capacitor
EEV-FK1H221P	C21	0	DNP				SMD		Aluminum Electrolytic Capacitors - SMD
C3216X5R1V226M160AC-T	C23-C28	6	22 μ F	20%	35V		1206	TDK	Multilayer Ceramic Capacitor
16TQC68MYF	C111, C112	0	DNP				SMD		Tantalum Capacitor - Polymer SMD
108-0740-001	J1-J4	4						Johnson Components	Banana Jack
69190-202HLF	JP1-JP5	5					THOLE	BERG/FCI	Jumper
SSL-LXA3025IGC-TR	LED1	1					SMD	LUMEX	3mmx2.5mm Surface Mount LED
2N7002-7-F-T	Q1	1					SOT-23	Various	N-Channel 60V 115mA MOSFET
H2511-00R00-1/10W-T	R1	1	0 Ω	1%		1/10W	603	Various	Thick Film Chip Resistor
H2515-DNP	R20	0	DNP				2512		
H2511-03321-1/10W1-T	R30, R31	2	3.32k Ω	1%		1/10W	603	Various	Thick Film Chip Resistor
H2511-01241-1/10W1-T	RFB1	1	1.24k Ω	1%		1/10W	603	Various	Thick Film Chip Resistor
H2511-03481-1/10W1-T	RFB2	1	3.48k Ω	1%		1/10W	603	Various	Thick Film Chip Resistor
H2511-07150-1/10W1-T	RFB3	1	715 Ω	1%		1/10W	603	Various	Thick Film Chip Resistor
H2511-05900-1/10W1-T	RFB4	1	590 Ω	1%		1/10W	603	Various	Thick Film Chip Resistor
H2511-04640-1/10W1-T	RFB5	1	464 Ω	1%		1/10W	603	Various	Thick Film Chip Resistor
GT11MCBE	SW1	1					THOLE	ITT CANNON	SPDT Toggle Switch ROHS
5002	TP1, TP5-TP8, TP10, TP11, TP14, TP15	9						Keystone	Test Point White
ISL8216MIRZ	U1	1					HDA	Intersil	15mmx15m DC/DC Power Module

Efficiency Performance

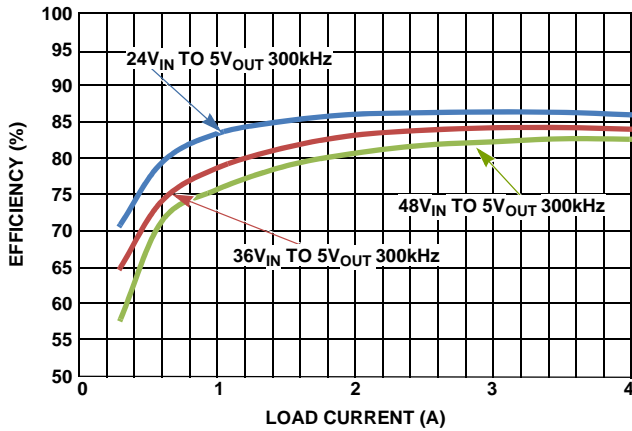

FIGURE 12. EFFICIENCY vs LOAD CURRENT (5V_{OUT} AT 300kHz)

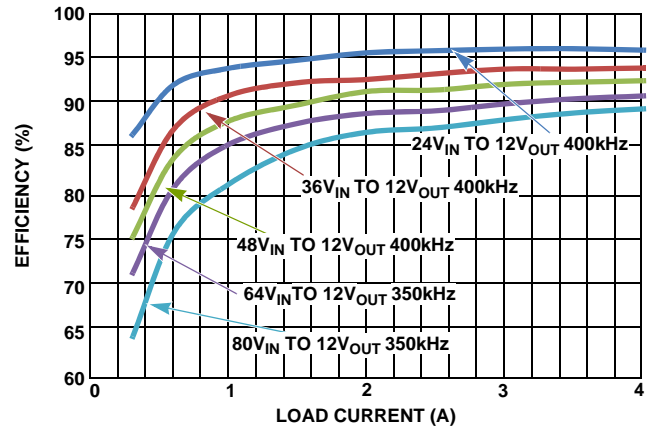

FIGURE 13. EFFICIENCY vs LOAD CURRENT (12V_{OUT})

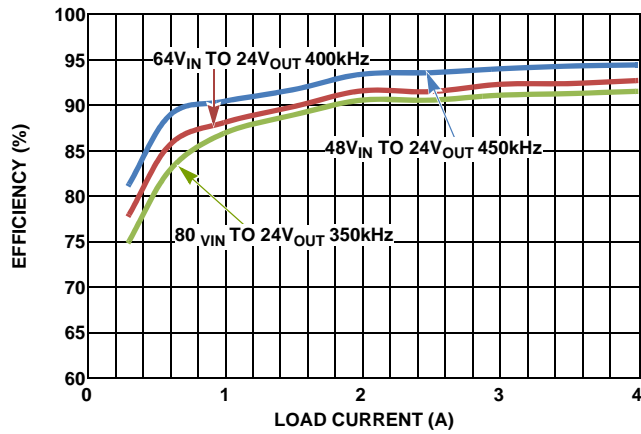

FIGURE 14. EFFICIENCY vs LOAD CURRENT (24V_{OUT})

Radiated Emission Performance

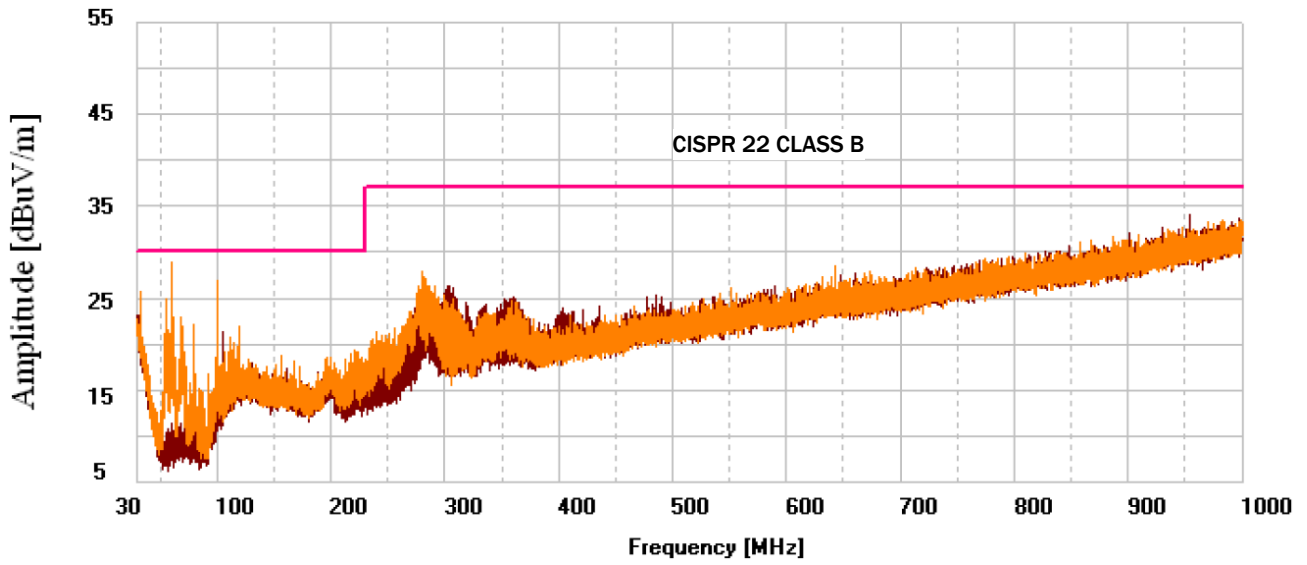

FIGURE 15. RADIATED EMISSION AT 24V_{IN} 5V_{OUT} 4A

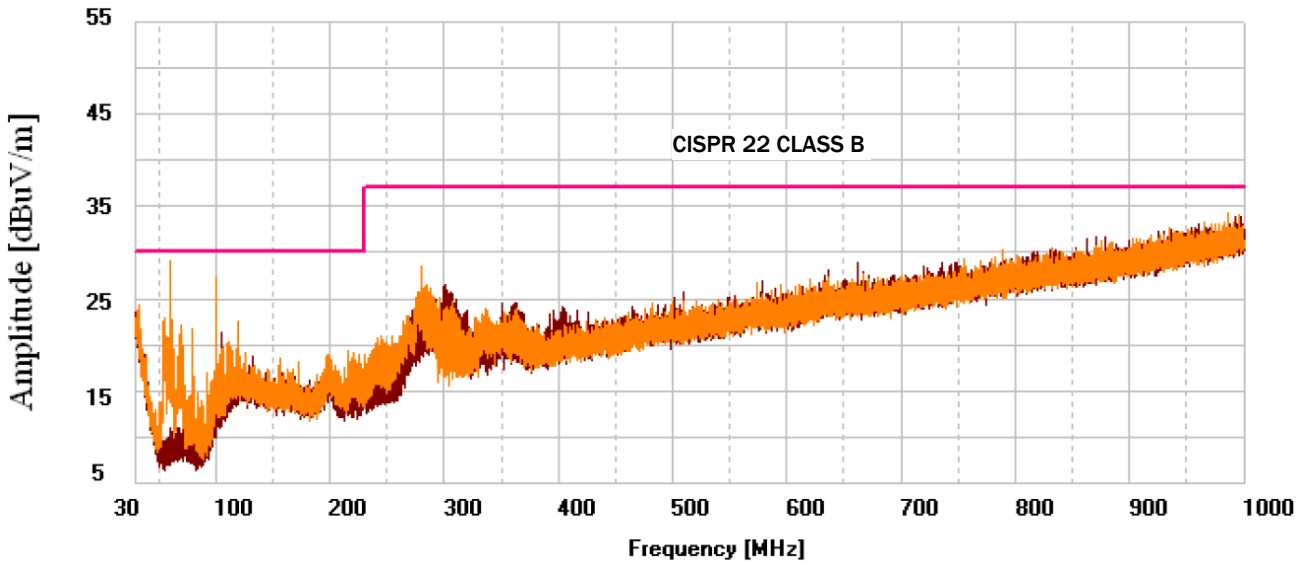

FIGURE 16. RADIATED EMISSION AT 24V_{IN} 12V_{OUT} 4A

Intersil Corporation reserves the right to make changes in circuit design, software and/or specifications at any time without notice. Accordingly, the reader is cautioned to verify that the Application Note or Technical Brief is current before proceeding.

For information regarding Intersil Corporation and its products, see www.intersil.com

Mouser Electronics

Authorized Distributor

Click to View Pricing, Inventory, Delivery & Lifecycle Information:

[Intersil:](#)

[ISL8216MEVAL1Z](#)