

Features

- Incorporates the ARM920T™ ARM® Thumb® Processor
 - 200 MIPS at 180 MHz, Memory Management Unit
 - 16-KByte Data Cache, 16-KByte Instruction Cache, Write Buffer
 - In-circuit Emulator including Debug Communication Channel
 - Mid-level Implementation Embedded Trace Macrocell™ (256-ball BGA Package only)
- Low Power: On VDDCORE 24.4 mA in Normal Mode, 520 µA in Standby Mode
- Additional Embedded Memories
 - 16K Bytes of SRAM and 128K Bytes of ROM
- External Bus Interface (EBI)
 - Supports SDRAM, Static Memory, Burst Flash, Glueless Connection to CompactFlash® and NAND Flash/SmartMedia®
- System Peripherals for Enhanced Performance:
 - Enhanced Clock Generator and Power Management Controller
 - Two On-chip Oscillators with Two PLLs
 - Very Slow Clock Operating Mode and Software Power Optimization Capabilities
 - Four Programmable External Clock Signals
 - System Timer Including Periodic Interrupt, Watchdog and Second Counter
 - Real-time Clock with Alarm Interrupt
 - Debug Unit, Two-wire UART and Support for Debug Communication Channel
 - Advanced Interrupt Controller with 8-level Priority, Individually Maskable Vectored Interrupt Sources, Spurious Interrupt Protected
 - Seven External Interrupt Sources and One Fast Interrupt Source
 - Four 32-bit PIO Controllers with Up to 122 Programmable I/O Lines, Input Change Interrupt and Open-drain Capability on Each Line
 - 20-channel Peripheral DMA Controller (PDC)
- Ethernet MAC 10/100 Base-T
 - Media Independent Interface (MII) or Reduced Media Independent Interface (RMII)
 - Integrated 28-byte FIFOs and Dedicated DMA Channels for Receive and Transmit
- USB 2.0 Full Speed (12 Mbits per second) Host Double Port
 - Dual On-chip Transceivers (Single Port Only on 208-lead PQFP Package)
 - Integrated FIFOs and Dedicated DMA Channels
- USB 2.0 Full Speed (12 Mbits per second) Device Port
 - On-chip Transceiver, 2-Kbyte Configurable Integrated FIFOs
- Multimedia Card Interface (MCI)
 - Automatic Protocol Control and Fast Automatic Data Transfers
 - MMC and SD Memory Card-compliant, Supports Up to Two SD Memory Cards
- Three Synchronous Serial Controllers (SSC)
 - Independent Clock and Frame Sync Signals for Each Receiver and Transmitter
 - I²S Analog Interface Support, Time Division Multiplex Support
 - High-speed Continuous Data Stream Capabilities with 32-bit Data Transfer
- Four Universal Synchronous/Asynchronous Receiver/Transmitters (USART)
 - Support for ISO7816 T0/T1 Smart Card
 - Hardware Handshaking
 - RS485 Support, IrDA® Up To 115 Kbps
 - Full Modem Control Lines on USART1
- Master/Slave Serial Peripheral Interface (SPI)
 - 8- to 16-bit Programmable Data Length, 4 External Peripheral Chip Selects



ARM920T-based Microcontroller

AT91RM9200

Rev. 1768I-ATARM-09-Jul-09



- **Two 3-channel, 16-bit Timer/Counters (TC)**
 - Three External Clock Inputs, Two Multi-purpose I/O Pins per Channel
 - Double PWM Generation, Capture/Waveform Mode, Up/Down Capability
- **Two-wire Interface (TWI)**
 - Master Mode Support, All 2-wire Atmel EEPROMs Supported
- **IEEE® 1149.1 JTAG Boundary Scan on All Digital Pins**
- **Power Supplies**
 - 1.65V to 1.95V for VDDCORE, VDDOSC and VDDPLL
 - 3.0V to 3.6V for VDDIOP (Peripheral I/Os) and for VDDIOM (Memory I/Os)
- **Available in a 208-pin Green PQFP or 256-ball RoHS-compliant BGA Package**

1. Description

The AT91RM9200 is a complete system-on-chip built around the ARM920T ARM Thumb processor. It incorporates a rich set of system and application peripherals and standard interfaces in order to provide a single-chip solution for a wide range of compute-intensive applications that require maximum functionality at minimum power consumption at lowest cost.

The AT91RM9200 incorporates a high-speed on-chip SRAM workspace, and a low-latency External Bus Interface (EBI) for seamless connection to whatever configuration of off-chip memories and memory-mapped peripherals is required by the application. The EBI incorporates controllers for synchronous DRAM (SDRAM), Burst Flash and Static memories and features specific circuitry facilitating the interface for NAND Flash/SmartMedia and Compact Flash.

The Advanced Interrupt Controller (AIC) enhances the interrupt handling performance of the ARM920T processor by providing multiple vectored, prioritized interrupt sources and reducing the time taken to transfer to an interrupt handler.

The Peripheral DMA Controller (PDC) provides DMA channels for all the serial peripherals, enabling them to transfer data to or from on- and off-chip memories without processor intervention. This reduces the processor overhead when dealing with transfers of continuous data streams. The AT91RM9200 benefits from a new generation of PDC which includes dual pointers that simplify significantly buffer chaining.

The set of Parallel I/O (PIO) controllers multiplex the peripheral input/output lines with general-purpose data I/Os for maximum flexibility in device configuration. An input change interrupt, open drain capability and programmable pull-up resistor is included on each line.

The Power Management Controller (PMC) keeps system power consumption to a minimum by selectively enabling/disabling the processor and various peripherals under software control. It uses an enhanced clock generator to provide a selection of clock signals including a slow clock (32 kHz) to optimize power consumption and performance at all times.

The AT91RM9200 integrates a wide range of standard interfaces including USB 2.0 Full Speed Host and Device and Ethernet 10/100 Base-T Media Access Controller (MAC), which provides connection to a extensive range of external peripheral devices and a widely used networking layer. In addition, it provides an extensive set of peripherals that operate in accordance with several industry standards, such as those used in audio, telecom, Flash Card, infrared and Smart Card applications.

To complete the offer, the AT91RM9200 benefits from the integration of a wide range of debug features including JTAG-ICE, a dedicated UART debug channel (DBGU) and an embedded real time trace. This enables the development and debug of all applications, especially those with real-time constraints.

2. Block Diagram

Bold arrows (**→**) indicate master-to-slave dependency.

Figure 2-1. AT91RM9200 Block Diagram

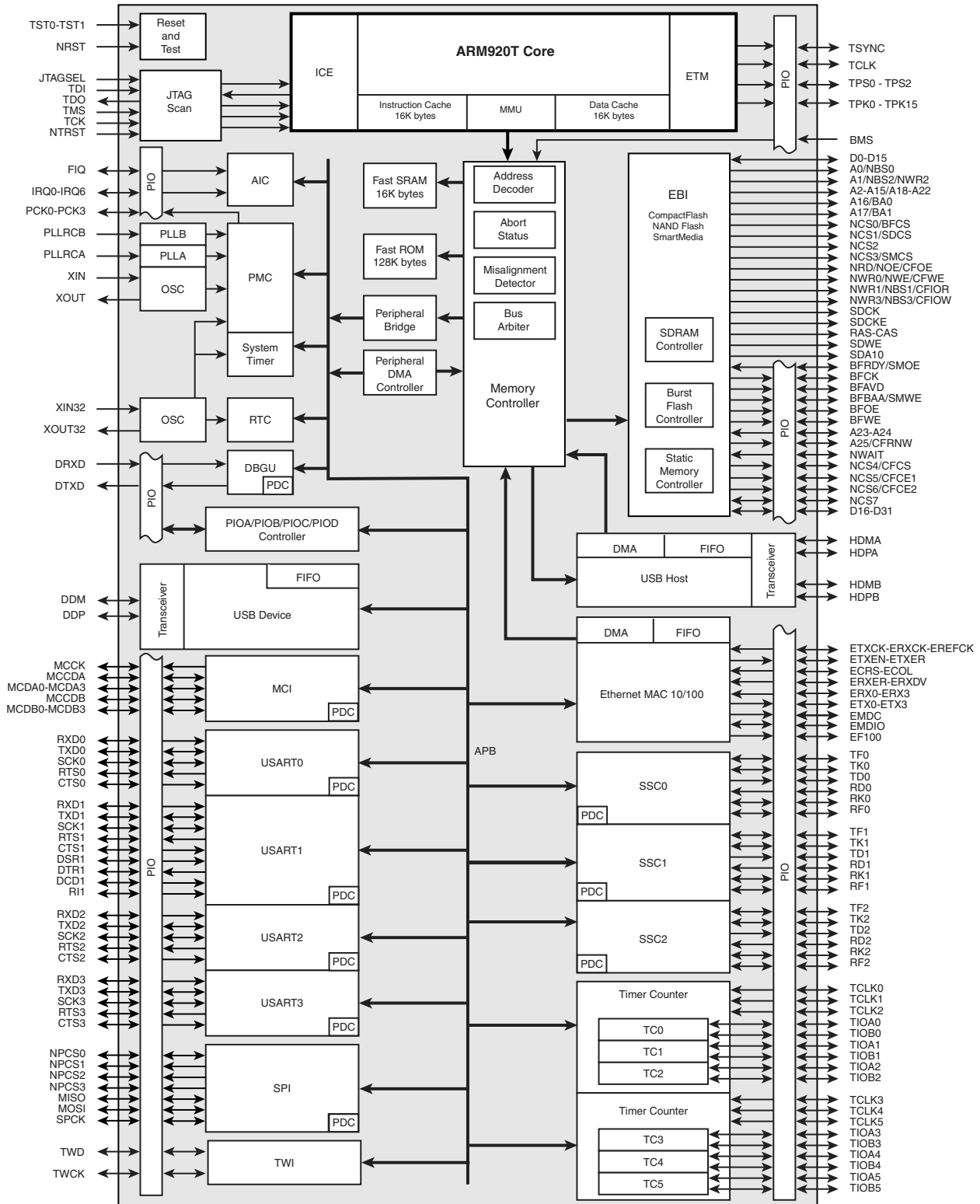

3. Signal Description

Table 3-1. Signal Description by Peripheral

Pin Name	Function	Type	Active Level	Comments
Power				
VDDIOM	Memory I/O Lines Power Supply	Power		3.0V to 3.6V
VDDIOP	Peripheral I/O Lines Power Supply	Power		3.0V to 3.6V
VDDPLL	Oscillator and PLL Power Supply	Power		1.65V to 1.95V
VDDCORE	Core Chip Power Supply	Power		1.65V to 1.95V
VDDOSC	Oscillator Power Supply	Power		1.65V to 1.95V
GND	Ground	Ground		
GNDPLL	PLL Ground	Ground		
GNDOSC	Oscillator Ground	Ground		
Clocks, Oscillators and PLLs				
XIN	Main Crystal Input	Input		
XOUT	Main Crystal Output	Output		
XIN32	32KHz Crystal Input	Input		
XOUT32	32KHz Crystal Output	Output		
PLLRC A	PLL A Filter	Input		
PLLRC B	PLL B Filter	Input		
PCK0 - PCK3	Programmable Clock Output	Output		
ICE and JTAG				
TCK	Test Clock	Input		Schmitt trigger
TDI	Test Data In	Input		Internal Pull-up, Schmitt trigger
TDO	Test Data Out	Output		Tri-state
TMS	Test Mode Select	Input		Internal Pull-up, Schmitt trigger
NTRST	Test Reset Signal	Input	Low	Internal Pull-up, Schmitt trigger
JTAGSEL	JTAG Selection	Input		Schmitt trigger
ETM™				
TSYNC	Trace Synchronization Signal	Output		
TCLK	Trace Clock	Output		
TPS0 - TPS2	Trace ARM Pipeline Status	Output		
TPK0 - TPK15	Trace Packet Port	Output		
Reset/Test				
NRST	Microcontroller Reset	Input	Low	No on-chip pull-up, Schmitt trigger
TST0 - TST1	Test Mode Select	Input		Must be tied low for normal operation, Schmitt trigger

Table 3-1. Signal Description by Peripheral

Pin Name	Function	Type	Active Level	Comments
Memory Controller				
BMS	Boot Mode Select	Input		
Debug Unit				
DRXD	Debug Receive Data	Input		Debug Receive Data
DTXD	Debug Transmit Data	Output		Debug Transmit Data
AIC				
IRQ0 - IRQ6	External Interrupt Inputs	Input		
FIQ	Fast Interrupt Input	Input		
PIO				
PA0 - PA31	Parallel IO Controller A	I/O		Pulled-up input at reset
PB0 - PB29	Parallel IO Controller B	I/O		Pulled-up input at reset
PC0 - PC31	Parallel IO Controller C	I/O		Pulled-up input at reset
PD0 - PD27	Parallel IO Controller D	I/O		Pulled-up input at reset
EBI				
D0 - D31	Data Bus	I/O		Pulled-up input at reset
A0 - A25	Address Bus	Output		0 at reset
SMC				
NCS0 - NCS7	Chip Select Lines	Output	Low	1 at reset
NWR0 - NWR3	Write Signal	Output	Low	1 at reset
NOE	Output Enable	Output	Low	1 at reset
NRD	Read Signal	Output	Low	1 at reset
NUB	Upper Byte Select	Output	Low	1 at reset
NLB	Lower Byte Select	Output	Low	1 at reset
NWE	Write Enable	Output	Low	1 at reset
NWAIT	Wait Signal	Input	Low	
NBS0 - NBS3	Byte Mask Signal	Output	Low	1 at reset
EBI for CompactFlash Support				
CFCE1 - CFCE2	CompactFlash Chip Enable	Output	Low	
CFOE	CompactFlash Output Enable	Output	Low	
CFWE	CompactFlash Write Enable	Output	Low	
CFIOR	CompactFlash IO Read	Output	Low	
CFIOW	CompactFlash IO Write	Output	Low	
CFRNW	CompactFlash Read Not Write	Output		
CFCS	CompactFlash Chip Select	Output	Low	

Table 3-1. Signal Description by Peripheral

Pin Name	Function	Type	Active Level	Comments
EBI for NAND Flash/SmartMedia Support				
SMCS	NAND Flash/SmartMedia Chip Select	Output	Low	
SMOE	NAND Flash/SmartMedia Output Enable	Output	Low	
SMWE	NAND Flash/SmartMedia Write Enable	Output	Low	
SDRAM Controller				
SDCK	SDRAM Clock	Output		
SDCKE	SDRAM Clock Enable	Output	High	
SDCS	SDRAM Controller Chip Select	Output	Low	
BA0 - BA1	Bank Select	Output		
SDWE	SDRAM Write Enable	Output	Low	
RAS - CAS	Row and Column Signal	Output	Low	
SDA10	SDRAM Address 10 Line	Output		
Burst Flash Controller				
BFCK	Burst Flash Clock	Output		
BFCS	Burst Flash Chip Select	Output	Low	
BFAVD	Burst Flash Address Valid	Output	Low	
BFBA	Burst Flash Address Advance	Output	Low	
BFOE	Burst Flash Output Enable	Output	Low	
BFRDY	Burst Flash Ready	Input	High	
BFWE	Burst Flash Write Enable	Output	Low	
Multimedia Card Interface				
MCK	Multimedia Card Clock	Output		
MCCDA	Multimedia Card A Command	I/O		
MCDA0 - MCDA3	Multimedia Card A Data	I/O		
MCCDB	Multimedia Card B Command	I/O		
MCDB0 - MCDB3	Multimedia Card B Data	I/O		
USART				
SCK0 - SCK3	Serial Clock	I/O		
TXD0 - TXD3	Transmit Data	Output		
RXD0 - RXD3	Receive Data	Input		
RTS0 - RTS3	Ready To Send	Output		
CTS0 - CTS3	Clear To Send	Input		
DSR1	Data Set Ready	Input		
DTR1	Data Terminal Ready	Output		
DCD1	Data Carrier Detect	Input		
RI1	Ring Indicator	Input		

Table 3-1. Signal Description by Peripheral

Pin Name	Function	Type	Active Level	Comments
USB Device Port				
DDM	USB Device Port Data -	Analog		
DDP	USB Device Port Data +	Analog		
USB Host Port				
HDMA	USB Host Port A Data -	Analog		
HDPA	USB Host Port A Data +	Analog		
HDMB	USB Host Port B Data -	Analog		
HDPB	USB Host Port B Data +	Analog		
Ethernet MAC				
EREFCK	Reference Clock	Input		RMII only
ETXCK	Transmit Clock	Input		MII only
ERXCK	Receive Clock	Input		MII only
ETXEN	Transmit Enable	Output		
ETX0 - ETX3	Transmit Data	Output		ETX0 - ETX1 only in RMII
ETXER	Transmit Coding Error	Output		MII only
ERXDV	Receive Data Valid	Input		MII only
ECRSDV	Carrier Sense and Data Valid	Input		RMII only
ERX0 - ERX3	Receive Data	Input		ERX0 - ERX1 only in RMII
ERXER	Receive Error	Input		
ECRS	Carrier Sense	Input		MII only
ECOL	Collision Detected	Input		MII only
EMDC	Management Data Clock	Output		
EMDIO	Management Data Input/Output	I/O		
EF100	Force 100 Mbts/sec.	Output	High	RMII only
Synchronous Serial Controller				
TD0 - TD2	Transmit Data	Output		
RD0 - RD2	Receive Data	Input		
TK0 - TK2	Transmit Clock	I/O		
RK0 - RK2	Receive Clock	I/O		
TF0 - TF2	Transmit Frame Sync	I/O		
RF0 - RF2	Receive Frame Sync	I/O		
Timer/Counter				
TCLK0 - TCLK5	External Clock Input	Input		
TIOA0 - TIOA5	I/O Line A	I/O		
TIOB0 - TIOB5	I/O Line B	I/O		

Table 3-1. Signal Description by Peripheral

Pin Name	Function	Type	Active Level	Comments
SPI				
MISO	Master In Slave Out	I/O		
MOSI	Master Out Slave In	I/O		
SPCK	SPI Serial Clock	I/O		
NPCS0	SPI Peripheral Chip Select 0	I/O	Low	
NPCS1 - NPCS3	SPI Peripheral Chip Select	Output	Low	
Two-Wire Interface				
TWD	Two-wire Serial Data	I/O		
TWCK	Two-wire Serial Clock	I/O		

4. Package and Pinout

The AT91RM9200 is available in two packages:

- 208-pin PQFP, 31.2 x 31.2 mm, 0.5 mm pitch
- 256-ball BGA, 15 x 15 mm, 0.8 mm ball pitch

The product features of the 256-ball BGA package are extended compared to the 208-lead PQFP package. The features that are available only with the 256-ball BGA package are:

- Parallel I/O Controller D
- ETM™ port with outputs multiplexed on the PIO Controller D
- a second USB Host transceiver, opening the Hub capabilities of the embedded USB Host.

4.1 208-pin PQFP Package Outline

Figure 4-1 shows the orientation of the 208-pin PQFP package.

A detailed mechanical description is given in the section “AT91RM9200 Mechanical Characteristics” of the product datasheet.

Figure 4-1. 208-pin PQFP Package (Top View)

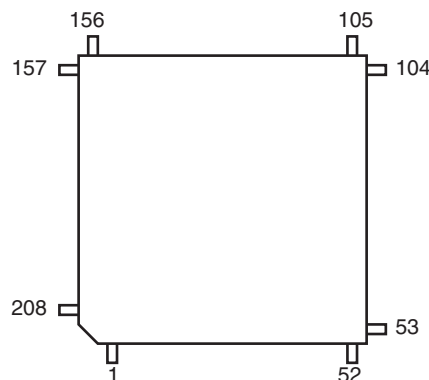

4.2 208-pin PQFP Package Pinout

Table 4-1. AT91RM9200 Pinout for 208-pin PQFP Package

Pin Number	Signal Name	Pin Number	Signal Name	Pin Number	Signal Name	Pin Number	Signal Name
1	PC24	37	VDDPLL	73	PA27	109	TMS
2	PC25	38	PLLRCB	74	PA28	110	NTRST
3	PC26	39	GNDPLL	75	VDDIOP	111	VDDIOP
4	PC27	40	VDDIOP	76	GND	112	GND
5	PC28	41	GND	77	PA29	113	TST0
6	PC29	42	PA0	78	PA30	114	TST1
7	VDDIOM	43	PA1	79	PA31/BMS	115	NRST
8	GND	44	PA2	80	PB0	116	VDDCORE
9	PC30	45	PA3	81	PB1	117	GND
10	PC31	46	PA4	82	PB2	118	PB23
11	PC10	47	PA5	83	PB3	119	PB24
12	PC11	48	PA6	84	PB4	120	PB25
13	PC12	49	PA7	85	PB5	121	PB26
14	PC13	50	PA8	86	PB6	122	PB27
15	PC14	51	PA9	87	PB7	123	PB28
16	PC15	52	PA10	88	PB8	124	PB29
17	PC0	53	PA11	89	PB9	125	HDMA
18	PC1	54	PA12	90	PB10	126	HDPA
19	VDDCORE	55	PA13	91	PB11	127	DDM
20	GND	56	VDDIOP	92	PB12	128	DDP
21	PC2	57	GND	93	VDDIOP	129	VDDIOP
22	PC3	58	PA14	94	GND	130	GND
23	PC4	59	PA15	95	PB13	131	VDDIOM
24	PC5	60	PA16	96	PB14	132	GND
25	PC6	61	PA17	97	PB15	133	A0/NBS0
26	VDDIOM	62	VDDCORE	98	PB16	134	A1/NBS2/NWR2
27	GND	63	GND	99	PB17	135	A2
28	VDDPLL	64	PA18	100	PB18	136	A3
29	PLLRCB	65	PA19	101	PB19	137	A4
30	GNDPLL	66	PA20	102	PB20	138	A5
31	XOUT	67	PA21	103	PB21	139	A6
32	XIN	68	PA22	104	PB22	140	A7
33	VDDOSC	69	PA23	105	JTAGSEL	141	A8
34	GNDOSC	70	PA24	106	TDI	142	A9
35	XOUT32	71	PA25	107	TDO	143	A10
36	XIN32	72	PA26	108	TCK	144	SDA10

Table 4-1. AT91RM9200 Pinout for 208-pin PQFP Package (Continued)

Pin Number	Signal Name	Pin Number	Signal Name	Pin Number	Signal Name	Pin Number	Signal Name
145	A11	161	PC7	177	CAS	193	D10
146	VDDIOM	162	PC8	178	SDWE	194	D11
147	GND	163	PC9	179	D0	195	D12
148	A12	164	VDDIOM	180	D1	196	D13
149	A13	165	GND	181	D2	197	D14
150	A14	166	NCS0/BFCS	182	D3	198	D15
151	A15	167	NCS1/SDCS	183	VDDIOM	199	VDDIOM
152	VDDCORE	168	NCS2	184	GND	200	GND
153	GND	169	NCS3/SMCS	185	D4	201	PC16
154	A16/BA0	170	NRD/NOE/CFOE	186	D5	202	PC17
155	A17/BA1	171	NWR0/NWE/CFWE	187	D6	203	PC18
156	A18	172	NWR1/NBS1/CFIOR	188	VDDCORE	204	PC19
157	A19	173	NWR3/NBS3/CFIOW	189	GND	205	PC20
158	A20	174	SDCK	190	D7	206	PC21
159	A21	175	SDCKE	191	D8	207	PC22
160	A22	176	RAS	192	D9	208	PC23

Note: 1. Shaded cells define the pins powered by VDDIOM.

4.3 256-ball BGA Package Outline

Figure 4-2 shows the orientation of the 256-ball LFBGA package.

A detailed mechanical description is given in the section “AT91RM9200 Mechanical Characteristics” of the product datasheet.

Figure 4-2. 256-ball LFBGA Package (Top View)

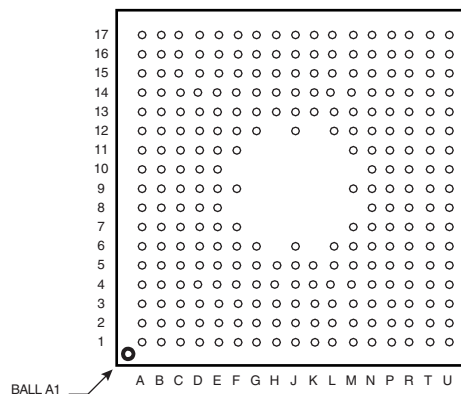

4.4 256-ball BGA Package Pinout

Table 4-2. AT91RM9200 Pinout for 256-ball BGA Package

Pin	Signal Name	Pin	Signal Name	Pin	Signal Name	Pin	Signal Name
A1	TDI	C3	PD14	E5	TCK	G14	PA1
A2	JTAGSEL	C4	PB22	E6	GND	G15	PA2
A3	PB20	C5	PB19	E7	PB15	G16	PA3
A4	PB17	C6	PD10	E8	GND	G17	XIN32
A5	PD11	C7	PB13	E9	PB7	H1	PD23
A6	PD8	C8	PB12	E10	PB3	H2	PD20
A7	VDDIOP	C9	PB6	E11	PA29	H3	PD22
A8	PB9	C10	PB1	E12	PA26	H4	PD21
A9	PB4	C11	GND	E13	PA25	H5	VDDIOP
A10	PA31/BMS	C12	PA20	E14	PA9	H13	VDDPLL
A11	VDDIOP	C13	PA18	E15	PA6	H14	VDDIOP
A12	PA23	C14	VDDCORE	E16	PD3	H15	GNDPLL
A13	PA19	C15	GND	E17	PD0	H16	GND
A14	GND	C16	PA8	F1	PD16	H17	XOUT32
A15	PA14	C17	PD5	F2	GND	J1	PD25
A16	VDDIOP	D1	TST1	F3	PB23	J2	PD27
A17	PA13	D2	VDDIOP	F4	PB25	J3	PD24
B1	TDO	D3	VDDIOP	F5	PB24	J4	PD26
B2	PD13	D4	GND	F6	VDDCORE	J5	PB28
B3	PB18	D5	VDDIOP	F7	PB16	J6	PB29
B4	PB21	D6	PD7	F9	PB11	J12	GND
B5	PD12	D7	PB14	F11	PA30	J13	GNDOSC
B6	PD9	D8	VDDIOP	F12	PA28	J14	VDDOSC
B7	GND	D9	PB8	F13	PA4	J15	VDDPLL
B8	PB10	D10	PB2	F14	PD2	J16	GNDPLL
B9	PB5	D11	GND	F15	PD1	J17	XIN
B10	PB0	D12	PA22	F16	PA5	K1	HDPA
B11	VDDIOP	D13	PA21	F17	PLLRCB	K2	DDM
B12	PA24	D14	PA16	G1	PD19	K3	HDMA
B13	PA17	D15	PA10	G2	PD17	K4	VDDIOP
B14	PA15	D16	PD6	G3	GND	K5	DDP
B15	PA11	D17	PD4	G4	PB26	K13	PC5
B16	PA12	E1	NRST	G5	PD18	K14	PC4
B17	PA7	E2	NTRST	G6	PB27	K15	PC6
C1	TMS	E3	GND	G12	PA27	K16	VDDIOM
C2	PD15	E4	TST0	G13	PA0	K17	XOUT

Table 4-2. AT91RM9200 Pinout for 256-ball BGA Package (Continued)

Pin	Signal Name	Pin	Signal Name	Pin	Signal Name	Pin	Signal Name
L1	GND	N2	A5	P13	D15	T7	NWR1/NBS1/ CFIOR
L2	HDPB	N3	A9	P14	PC26	T8	SDWE
L3	HDMB	N4	A4	P15	PC27	T9	GND
L4	A6	N5	A14	P16	VDDIOM	T10	VDDCORE
L5	GND	N6	SDA10	P17	GND	T11	D9
L6	VDDIOP	N7	A8	R1	GND	T12	D12
L12	PC10	N8	A21	R2	GND	T13	GND
L13	PC15	N9	NRD/NOE/CFOE	R3	A18	T14	PC19
L14	PC2	N10	RAS	R4	A20	T15	PC21
L15	PC3	N11	D2	R5	PC8	T16	PC23
L16	VDDCORE	N12	GND	R6	VDDIOM	T17	PC25
L17	PLLRCA	N13	PC28	R7	NCS3/SMCS	U1	VDDCORE
M1	VDDIOM	N14	PC31	R8	NWR3/NBS3/ CFIOW	U2	GND
M2	GND	N15	PC30	R9	D0	U3	A16/BA0
M3	A3	N16	PC11	R10	VDDIOM	U4	A19
M4	A1/NBS2/NWR2	N17	PC12	R11	D8	U5	GND
M5	A10	P1	A7	R12	D13	U6	NCS0/BFCS
M6	A2	P2	A13	R13	PC17	U7	SDCK
M7	GND	P3	A12	R14	VDDIOM	U8	CAS
M9	NCS1/SDCS	P4	VDDIOM	R15	PC24	U9	D3
M11	D4	P5	A11	R16	PC29	U10	D6
M12	GND	P6	A22	R17	VDDIOM	U11	D7
M13	PC13	P7	PC9	T1	A15	U12	D11
M14	PC1	P8	NWR0/NWE/CFWE	T2	VDDCORE	U13	D14
M15	PC0	P9	SDCKE	T3	A17/BA1	U14	PC16
M16	GND	P10	D1	T4	PC7	U15	PC18
M17	PC14	P11	D5	T5	VDDIOM	U16	PC20
N1	A0/NBS0	P12	D10	T6	NCS2	U17	PC22

Note: 1. Shaded cells define the balls powered by VDDIOM.

5. Power Considerations

5.1 Power Supplies

The AT91RM9200 has five types of power supply pins:

- VDDCORE pins. They power the core, including processor, memories and peripherals; voltage ranges from 1.65V to 1.95V, 1.8V nominal.
- VDDIOM pins. They power the External Bus Interface I/O lines; voltage ranges from 3.0V to 3.6V, 3V or 3.3V nominal.
- VDDIOP pins. They power the Peripheral I/O lines and the USB transceivers; voltage ranges from 3.0V to 3.6V, 3V or 3.3V nominal.
- VDDPLL pins. They power the PLL cells; voltage ranges from 1.65V to 1.95V, 1.8V nominal.
- VDDOSC pin. They power both oscillators; voltage ranges from 1.65V to 1.95V, 1.8V nominal.

The double power supplies VDDIOM and VDDIOP are identified in [Table 4-1 on page 9](#) and [Table 4-2 on page 11](#). These supplies enable the user to power the device differently for interfacing with memories and for interfacing with peripherals.

Ground pins are common to all power supplies, except VDDPLL and VDDOSC pins. For these pins, GNDPLL and GNDOSC are provided, respectively.

5.2 Power Consumption

The AT91RM9200 consumes about 500 μ A of static current on VDDCORE at 25 $^{\circ}$ C. For dynamic power consumption, the AT91RM9200 consumes a maximum of 25 mA on VDDCORE at maximum speed in typical conditions (1.8V, 25 $^{\circ}$ C), processor running full-performance algorithm.

6. I/O Considerations

6.1 JTAG Port Pins

TMS and TDI are Schmitt trigger inputs and integrate internal pull-up resistors of 15 kOhm typical. TCK is a Schmitt trigger input without internal pull-up resistor.

TDO is a tri-state output. The JTAGSEL pin is used to select the JTAG boundary scan when asserted at a high level. The NTRST pin is used to initialize the EmbeddedICE™ TAP Controller.

6.2 Test Pin

The TST0 and TST1 pins are used for manufacturing test purposes when asserted high. As they do not integrate a pull-down resistor, they must be tied low during normal operations. Driving this line at a high level leads to unpredictable results.

6.3 Reset Pin

NRST is a Schmitt trigger without pull-up resistor. The NRST signal is inserted in the Boundary Scan.

6.4 PIO Controller A, B, C and D Lines

All the I/O lines PA0 to PA31, PB0 to PB29, PC0 to PC31 and PD0 to PD27 integrate a programmable pull-up resistor of 15 kOhm typical. Programming of this pull-up resistor is performed independently for each I/O line through the PIO Controllers.

After reset, all the I/O lines default as inputs with pull-up resistors enabled, except those which are multiplexed with the External Bus Interface signals that must be enabled as peripherals at reset. This is explicitly indicated in the column "Reset State" of the PIO Controller multiplexing tables.

7. Processor and Architecture

7.1 ARM920T Processor

- ARM9TDMI™-based on ARM Architecture v4T
- Two instruction sets
 - ARM High-performance 32-bit Instruction Set
 - Thumb High Code Density 16-bit Instruction Set
- 5-Stage Pipeline Architecture:
 - Instruction Fetch (F)
 - Instruction Decode (D)
 - Execute (E)
 - Data Memory (M)
 - Register Write (W)
- 16-Kbyte Data Cache, 16-Kbyte Instruction Cache
 - Virtually-addressed 64-way Associative Cache
 - 8 words per line
 - Write-through and write-back operation
 - Pseudo-random or Round-robin replacement
 - Low-power CAM RAM implementation
- Write Buffer
 - 16-word Data Buffer
 - 4-address Address Buffer
 - Software Control Drain
- Standard ARMv4 Memory Management Unit (MMU)
 - Access permission for sections
 - Access permission for large pages and small pages can be specified separately for each quarter of the pages
 - 16 embedded domains
 - 64 Entry Instruction TLB and 64 Entry Data TLB

8-, 16-, 32-bit Data Bus for Instructions and Data

7.2 Debug and Test

- Integrated EmbeddedICE

- Debug Unit
 - Two-pin UART
 - Debug Communication Channel
 - Chip ID Register
- Embedded Trace Macrocell: ETM9™ Rev2a
 - Medium Level Implementation
 - Half-rate Clock Mode
 - Four Pairs of Address Comparators
 - Two Data Comparators
 - Eight Memory Map Decoder Inputs
 - Two Counters
 - One Sequencer
 - One 18-byte FIFO
- IEEE1149.1 JTAG Boundary Scan on all Digital Pins

7.3 Boot Program

- Default Boot Program stored in ROM-based products
- Downloads and runs an application from external storage media into internal SRAM
- Downloaded code size depends on embedded SRAM size
- Automatic detection of valid application
- Bootloader supporting a wide range of non-volatile memories
 - SPI DataFlash® connected on SPI NPCS0
 - Two-wire EEPROM
 - 8-bit parallel memories on NCS0
- Boot Uploader in case no valid program is detected in external NVM and supporting several communication media
- Serial communication on a DBGU (XModem protocol)
- USB Device Port (DFU Protocol)

7.4 Embedded Software Services

- Compliant with ATPCS
- Compliant with AINSI/ISO Standard C
- Compiled in ARM/Thumb Interworking
- ROM Entry Service
- Tempo, Xmodem and DataFlash services
- CRC and Sine tables

7.5 Memory Controller

- Programmable Bus Arbiter handling four Masters
 - Internal Bus is shared by ARM920T, PDC, USB Host Port and Ethernet MAC Masters
 - Each Master can be assigned a priority between 0 and 7

- Address Decoder provides selection for
 - Eight external 256-Mbyte memory areas
 - Four internal 1-Mbyte memory areas
 - One 256-Mbyte embedded peripheral area
- Boot Mode Select Option
 - Non-volatile Boot Memory can be internal or external
 - Selection is made by BMS pin sampled at reset
- Abort Status Registers
 - Source, Type and all parameters of the access leading to an abort are saved
- Misalignment Detector
 - Alignment checking of all data accesses
 - Abort generation in case of misalignment
- Remap command
 - Provides remapping of an internal SRAM in place of the boot NVM

8. Memories

Figure 8-1. AT91RM9200 Memory Mapping

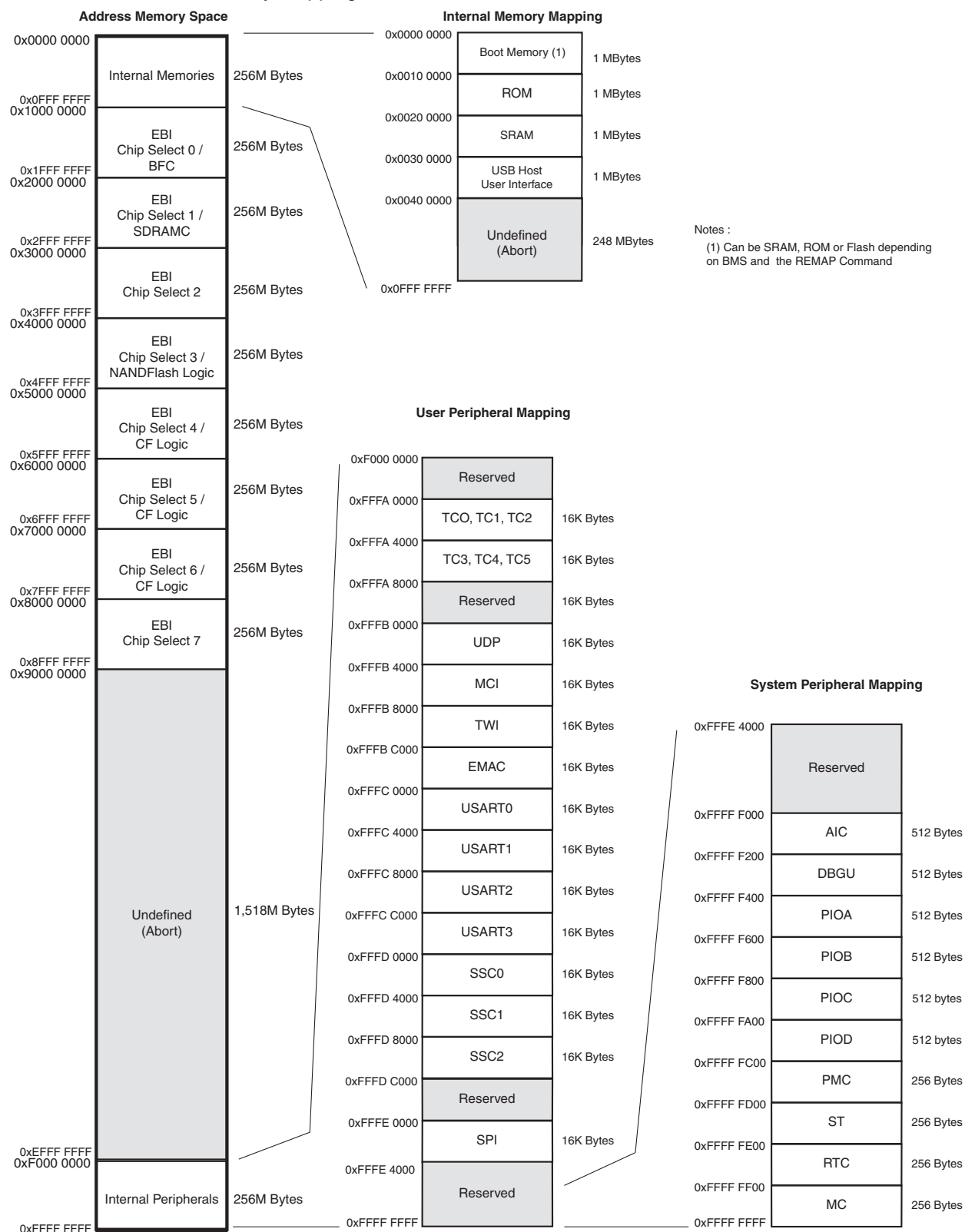

A first level of address decoding is performed by the Memory Controller, i.e., by the implementation of the Advanced System Bus (ASB) with additional features.

Decoding splits the 4G bytes of address space into 16 areas of 256M bytes. The areas 1 to 8 are directed to the EBI that associates these areas to the external chip selects NC0 to NCS7. The area 0 is reserved for the addressing of the internal memories, and a second level of decoding provides 1M bytes of internal memory area. The area 15 is reserved for the peripherals and provides access to the Advanced Peripheral Bus (APB).

Other areas are unused and performing an access within them provides an abort to the master requesting such an access.

8.1 Embedded Memories

8.1.1 Internal Memory Mapping

8.1.1.1 *Internal RAM*

The AT91RM9200 integrates a high-speed, 16-Kbyte internal SRAM. After reset and until the Remap Command is performed, the SRAM is only accessible at address 0x20 0000. After Remap, the SRAM is also available at address 0x0.

8.1.1.2 *Internal ROM*

The AT91RM9200 integrates a 128-Kbyte Internal ROM. At any time, the ROM is mapped at address 0x10 0000. It is also accessible at address 0x0 after reset and before the Remap Command if the BMS is tied high during reset.

8.1.1.3 *USB Host Port*

The AT91RM9200 integrates a USB Host Port Open Host Controller Interface (OHCI). The registers of this interface are directly accessible on the ASB Bus and are mapped like a standard internal memory at address 0x30 0000.

9. System Peripherals

A complete memory map is shown in [Figure 8-1 on page 17](#).

9.1 Reset Controller

- Two reset input lines (NRST and NTRST) providing, respectively:
- Initialization of the User Interface registers (defined in the user interface of each peripheral) and:
 - Sample the signals needed at bootup
 - Compel the processor to fetch the next instruction at address zero
- Initialization of the embedded ICE TAP controller

9.2 Advanced Interrupt Controller

- Controls the interrupt lines (nIRQ and nFIQ) of an ARM Processor
- Thirty-two individually maskable and vectored interrupt sources
 - Source 0 is reserved for the Fast Interrupt Input (FIQ)
 - Source 1 is reserved for system peripherals (ST, RTC, PMC, DBGU...)
 - Source 2 to Source 31 control thirty embedded peripheral interrupts or external interrupts
 - Programmable Edge-triggered or Level-sensitive Internal Sources
 - Programmable Positive/Negative Edge-triggered or High/Low Level-sensitive External Sources
- 8-level Priority Controller
 - Drives the Normal Interrupt of the processor
 - Handles priority of the interrupt sources 1 to 31
 - Higher priority interrupts can be served during service of lower priority interrupt
- Vectoring
 - Optimizes Interrupt Service Routine Branch and Execution
 - One 32-bit Vector Register per interrupt source
 - Interrupt Vector Register reads the corresponding current Interrupt Vector
- Protect Mode
 - Easy debugging by preventing automatic operations
- General Interrupt Mask
 - Provides processor synchronization on events without triggering an interrupt

9.3 Power Management Controller

- Optimizes the power consumption of the whole system
- Embeds and controls:
 - One Main Oscillator and One Slow Clock Oscillator (32.768Hz)
 - Two Phase Locked Loops (PLLs) and Dividers
 - Clock Prescalers
- Provides:
 - the Processor Clock PCK

- the Master Clock MCK
- the USB Clocks, UHPCK and UDPCK, respectively for the USB Host Port and the USB Device Port
- Programmable automatic PLL switch-off in USB Device suspend conditions
- up to thirty peripheral clocks
- four programmable clock outputs PCK0 to PCK3
- Four operating modes:
 - Normal Mode, Idle Mode, Slow Clock Mode, Standby Mode

9.4 Debug Unit

- System peripheral to facilitate debug of Atmel's ARM-based systems
- Composed of the following functions
 - Two-pin UART
 - Debug Communication Channel (DCC) support
 - Chip ID Registers
- Two-pin UART
 - Implemented features are 100% compatible with the standard Atmel USART
 - Independent receiver and transmitter with a common programmable Baud Rate Generator
 - Even, Odd, Mark or Space Parity Generation
 - Parity, Framing and Overrun Error Detection
 - Automatic Echo, Local Loopback and Remote Loopback Channel Modes
 - Interrupt generation
 - Support for two PDC channels with connection to receiver and transmitter
- Debug Communication Channel Support
 - Offers visibility of COMMRX and COMMTX signals from the ARM Processor
 - Interrupt generation
- Chip ID Registers
 - Identification of the device revision, sizes of the embedded memories, set of peripherals

9.5 PIO Controller

- Up to 32 programmable I/O Lines
- Fully programmable through Set/Clear Registers
- Multiplexing of two peripheral functions per I/O Line
- For each I/O Line (whether assigned to a peripheral or used as general purpose I/O)
 - Input change interrupt
 - Glitch filter
 - Multi-drive option enables driving in open drain
 - Programmable pull-up on each I/O line
 - Pin data status register, supplies visibility of the level on the pin at any time

- Synchronous output, provides Set and Clear of several I/O lines in a single write

10. User Peripherals

10.1 User Interface

The User Peripherals are mapped in the upper 256M bytes of the address space, between the addresses 0xFFFA 0000 and 0xFFFE 3FFF. Each peripheral has a 16-Kbyte address space.

A complete memory map is presented in [Figure 8-1 on page 17](#).

10.2 Peripheral Identifiers

The AT91RM9200 embeds a wide range of peripherals. [Table 10-1](#) defines the peripheral identifiers of the AT91RM9200. A peripheral identifier is required for the control of the peripheral interrupt with the Advanced Interrupt Controller and for the control of the peripheral clock with the Power Management Controller.

Table 10-1. Peripheral Identifiers

Peripheral ID	Peripheral Mnemonic	Peripheral Name	External Interrupt
0	AIC	Advanced Interrupt Controller	FIQ
1	SYSIRQ		
2	PIOA	Parallel I/O Controller A	
3	PIOB	Parallel I/O Controller B	
4	PIOC	Parallel I/O Controller C	
5	PIOD	Parallel I/O Controller D	
6	US0	USART 0	
7	US1	USART 1	
8	US2	USART 2	
9	US3	USART 3	
10	MCI	Multimedia Card Interface	
11	UDP	USB Device Port	
12	TWI	Two-wire Interface	
13	SPI	Serial Peripheral Interface	
14	SSC0	Synchronous Serial Controller 0	
15	SSC1	Synchronous Serial Controller 1	
16	SSC2	Synchronous Serial Controller 2	
17	TC0	Timer/Counter 0	
18	TC1	Timer/Counter 1	
19	TC2	Timer/Counter 2	
20	TC3	Timer/Counter 3	
21	TC4	Timer/Counter 4	
22	TC5	Timer/Counter 5	
23	UHP	USB Host Port	

Table 10-1. Peripheral Identifiers (Continued)

Peripheral ID	Peripheral Mnemonic	Peripheral Name	External Interrupt
24	EMAC	Ethernet MAC	
25	AIC	Advanced Interrupt Controller	IRQ0
26	AIC	Advanced Interrupt Controller	IRQ1
27	AIC	Advanced Interrupt Controller	IRQ2
28	AIC	Advanced Interrupt Controller	IRQ3
29	AIC	Advanced Interrupt Controller	IRQ4
30	AIC	Advanced Interrupt Controller	IRQ5
31	AIC	Advanced Interrupt Controller	IRQ6

10.3 Peripheral Multiplexing on PIO Lines

The AT91RM9200 features four PIO controllers:

- PIOA and PIOB, multiplexing I/O lines of the peripheral set
- PIOC, multiplexing the data bus bits 16 to 31 and several External Bus Interface control signals. Using PIOC pins increases the number of general-purpose I/O lines available but prevents 32-bit memory access
- PIOD, available in the 256-ball BGA package option only, multiplexing outputs of the peripheral set and the ETM port

Each PIO Controller controls up to 32 lines. Each line can be assigned to one of two peripheral functions, A or B. The tables in the following paragraphs define how the I/O lines of the peripherals A and B are multiplexed on the PIO Controllers A, B, C and D. The two columns “Function” and “Comments” have been inserted for the user’s own comments; they may be used to track how pins are defined in an application.

The column “Reset State” indicates whether the PIO line resets in I/O mode or in peripheral mode. If equal to “I/O”, the PIO line resets in input with the pull-up enabled so that the device is maintained in a static state as soon as the NRST pin is asserted. As a result, the bit corresponding to the PIO line in the register PIO_PSR (Peripheral Status Register) resets low.

If a signal name is in the “Reset State” column, the PIO line is assigned to this function and the corresponding bit in PIO_PSR resets high. This is the case for pins controlling memories, either address lines or chip selects, and that require the pin to be driven as soon as NRST raises. Note that the pull-up resistor is also enabled in this case.

See [Table 10-2 on page 23](#), [Table 10-3 on page 24](#), [Table 10-4 on page 25](#) and [Table 10-5 on page 26](#).

10.3.1 PIO Controller A Multiplexing

Table 10-2. Multiplexing on PIO Controller A

PIO Controller A				Application Usage	
I/O Line	Peripheral A	Peripheral B	Reset State	Function	Comments
PA0	MISO	PCK3	I/O		
PA1	MOSI	PCK0	I/O		
PA2	SPCK	IRQ4	I/O		
PA3	NPCS0	IRQ5	I/O		
PA4	NPCS1	PCK1	I/O		
PA5	NPCS2	TXD3	I/O		
PA6	NPCS3	RXD3	I/O		
PA7	ETXCK/EREFCK	PCK2	I/O		
PA8	ETXEN	MCCDB	I/O		
PA9	ETX0	MCDB0	I/O		
PA10	ETX1	MCDB1	I/O		
PA11	ECRS/ECRSVD	MCDB2	I/O		
PA12	ERX0	MCDB3	I/O		
PA13	ERX1	TCLK0	I/O		
PA14	ERXER	TCLK1	I/O		
PA15	EMDC	TCLK2	I/O		
PA16	EMDIO	IRQ6	I/O		
PA17	TXD0	TIOA0	I/O		
PA18	RXD0	TIOB0	I/O		
PA19	SCK0	TIOA1	I/O		
PA20	CTS0	TIOB1	I/O		
PA21	RTS0	TIOA2	I/O		
PA22	RXD2	TIOB2	I/O		
PA23	TXD2	IRQ3	I/O		
PA24	SCK2	PCK1	I/O		
PA25	TWD	IRQ2	I/O		
PA26	TWCK	IRQ1	I/O		
PA27	MCCK	TCLK3	I/O		
PA28	MCCDA	TCLK4	I/O		
PA29	MCDA0	TCLK5	I/O		
PA30	DRXD	CTS2	I/O		
PA31	DTXD	RTS2	I/O		

10.3.2 PIO Controller B Multiplexing

Table 10-3. Multiplexing on PIO Controller B

PIO Controller B				Application Usage	
I/O Line	Peripheral A	Peripheral B	Reset State	Function	Comments
PB0	TF0	RTS3	I/O		
PB1	TK0	CTS3	I/O		
PB2	TD0	SCK3	I/O		
PB3	RD0	MCDA1	I/O		
PB4	RK0	MCDA2	I/O		
PB5	RF0	MCDA3	I/O		
PB6	TF1	TIOA3	I/O		
PB7	TK1	TIOB3	I/O		
PB8	TD1	TIOA4	I/O		
PB9	RD1	TIOB4	I/O		
PB10	RK1	TIOA5	I/O		
PB11	RF1	TIOB5	I/O		
PB12	TF2	ETX2	I/O		
PB13	TK2	ETX3	I/O		
PB14	TD2	ETXER	I/O		
PB15	RD2	ERX2	I/O		
PB16	RK2	ERX3	I/O		
PB17	RF2	ERXDV	I/O		
PB18	RI1	ECOL	I/O		
PB19	DTR1	ERXCK	I/O		
PB20	TXD1		I/O		
PB21	RXD1		I/O		
PB22	SCK1		I/O		
PB23	DCD1		I/O		
PB24	CTS1		I/O		
PB25	DSR1	EF100	I/O		
PB26	RTS1		I/O		
PB27	PCK0		I/O		
PB28	FIQ		I/O		
PB29	IRQ0		I/O		

10.3.3 PIO Controller C Multiplexing

The PIO Controller C has no multiplexing and only peripheral A lines are used. Selecting Peripheral B on the PIO Controller C has no effect.

Table 10-4. Multiplexing on PIO Controller C

PIO Controller C				Application Usage	
I/O Line	Peripheral A	Peripheral B	Reset State	Function	Comments
PC0	BCK		I/O		
PC1	BFRDY/SMOE		I/O		
PC2	BFAVD		I/O		
PC3	BFBAA/SMWE		I/O		
PC4	BFOE		I/O		
PC5	BWE		I/O		
PC6	NWAIT		I/O		
PC7	A23		A23		
PC8	A24		A24		
PC9	A25/CFRNW		A25		
PC10	NCS4/CFCS		NCS4		
PC11	NCS5/CFCE1		NCS5		
PC12	NCS6/CFCE2		NCS6		
PC13	NCS7		NCS7		
PC14			I/O		
PC15			I/O		
PC16	D16		I/O		
PC17	D17		I/O		
PC18	D18		I/O		
PC19	D19		I/O		
PC20	D20		I/O		
PC21	D21		I/O		
PC22	D22		I/O		
PC23	D23		I/O		
PC24	D24		I/O		
PC25	D25		I/O		
PC26	D26		I/O		
PC27	D27		I/O		
PC28	D28		I/O		
PC29	D29		I/O		
PC30	D30		I/O		
PC31	D31		I/O		

10.3.4 PIO Controller D Multiplexing

The PIO Controller D multiplexes pure output signals on peripheral A connections, in particular from the EMAC MII interface and the ETM Port on the peripheral B connections.

The PIO Controller D is available only in the 256-ball BGA package option of the AT91RM9200.

Table 10-5. Multiplexing on PIO Controller D

PIO Controller D				Application Usage	
I/O Line	Peripheral A	Peripheral B	Reset State	Function	Comments
PD0	ETX0		I/O		
PD1	ETX1		I/O		
PD2	ETX2		I/O		
PD3	ETX3		I/O		
PD4	ETXEN		I/O		
PD5	ETXER		I/O		
PD6	DTXD		I/O		
PD7	PCK0	TSYNC	I/O		
PD8	PCK1	TCLK	I/O		
PD9	PCK2	TPS0	I/O		
PD10	PCK3	TPS1	I/O		
PD11		TPS2	I/O		
PD12		TPK0	I/O		
PD13		TPK1	I/O		
PD14		TPK2	I/O		
PD15	TD0	TPK3	I/O		
PD16	TD1	TPK4	I/O		
PD17	TD2	TPK5	I/O		
PD18	NPCS1	TPK6	I/O		
PD19	NPCS2	TPK7	I/O		
PD20	NPCS3	TPK8	I/O		
PD21	RTS0	TPK9	I/O		
PD22	RTS1	TPK10	I/O		
PD23	RTS2	TPK11	I/O		
PD24	RTS3	TPK12	I/O		
PD25	DTR1	TPK13	I/O		
PD26		TPK14	I/O		
PD27		TPK15	I/O		

10.3.5 System Interrupt

The System Interrupt is the wired-OR of the interrupt signals coming from:

- the Memory Controller
- the Debug Unit
- the System Timer
- the Real-Time Clock
- the Power Management Controller

The clock of these peripherals cannot be controlled and the Peripheral ID 1 can only be used within the Advanced Interrupt Controller.

10.3.6 External Interrupts

All external interrupt signals, i.e., the Fast Interrupt signal FIQ or the Interrupt signals IRQ0 to IRQ6, use a dedicated Peripheral ID. However, there is no clock control associated with these peripheral IDs.

10.4 External Bus Interface

- Integrates three External Memory Controllers:
 - Static Memory Controller
 - SDRAM Controller
 - Burst Flash Controller
- Additional logic for NAND Flash/SmartMedia and CompactFlash support
- Optimized External Bus:
 - 16- or 32-bit Data Bus
 - Up to 26-bit Address Bus, up to 64-Mbytes addressable
 - Up to 8 Chip Selects, each reserved to one of the eight Memory Areas
 - Optimized pin multiplexing to reduce latencies on External Memories
- Configurable Chip Select Assignment:
 - Burst Flash Controller or Static Memory Controller on NCS0
 - SDRAM Controller or Static Memory Controller on NCS1
 - Static Memory Controller on NCS3, Optional NAND Flash/SmartMedia Support
 - Static Memory Controller on NCS4 - NCS6, Optional CompactFlash Support
 - Static Memory Controller on NCS7

10.5 Static Memory Controller

- External memory mapping, 512-Mbyte address space
- Up to 8 Chip Select Lines
- 8- or 16-bit Data Bus
- Remap of Boot Memory
- Multiple Access Modes supported
 - Byte Write or Byte Select Lines
 - Two different Read Protocols for each Memory Bank
- Multiple device adaptability

- Compliant with LCD Module
- Programmable Setup Time Read/Write
- Programmable Hold Time Read/Write
- Multiple Wait State Management
 - Programmable Wait State Generation
 - External Wait Request
 - Programmable Data Float Time

10.6 SDRAM Controller

- Numerous configurations supported
 - **2K, 4K, 8K Row Address Memory Parts**
 - **SDRAM with two or four Internal Banks**
 - **SDRAM with 16- or 32-bit Data Path**
- Programming facilities
 - **Word, half-word, byte access**
 - **Automatic page break when Memory Boundary has been reached**
 - **Multibank Ping-pong Access**
 - **Timing parameters specified by software**
 - **Automatic refresh operation, refresh rate is programmable**
- **Energy-saving capabilities**
 - **Self-refresh and Low-power Modes supported**
- Error detection
 - **Refresh Error Interrupt**
- **SDRAM Power-up Initialization by software**
- **Latency is set to two clocks (CAS Latency of 1, 3 Not Supported)**
- **Auto Precharge Command not used**

10.7 Burst Flash Controller

- Multiple Access Modes supported
 - Asynchronous or Burst Mode Byte, Half-word or Word Read Accesses
 - Asynchronous Mode Half-word Write Accesses
- Adaptability to different device speed grades
 - Programmable Burst Flash Clock Rate
 - Programmable Data Access Time
 - Programmable Latency after Output Enable
- Adaptability to different device access protocols and bus interfaces
 - Two Burst Read Protocols: Clock Control Address Advance or Signal Controlled Address Advance
 - Multiplexed or separate address and data buses
 - Continuous Burst and Page Mode Accesses supported

10.8 Peripheral DMA Controller (PDC)

- Generates transfers to/from peripherals such as DBGU, USART, SSC, SPI and MCI
- Twenty channels
- One Master Clock cycle needed for a transfer from memory to peripheral
- Two Master Clock cycles needed for a transfer from peripheral to memory

10.9 System Timer

- One Period Interval Timer, 16-bit programmable counter
- One Watchdog Timer, 16-bit programmable counter
- One Real-time Timer, 20-bit free-running counter
- Interrupt Generation on event

10.10 Real-time Clock

- Low power consumption
- Full asynchronous design
- Two hundred year calendar
- Programmable Periodic Interrupt
- Alarm and update parallel load
- Control of alarm and update Time/Calendar Data In

10.11 USB Host Port

- Compliance with Open HCI Rev 1.0 specification
- Compliance with USB V2.0 Full-speed and Low-speed Specification
- Supports both Low-speed 1.5 Mbps and Full-speed 12 Mbps USB devices
- Root hub integrated with two downstream USB ports
- Two embedded USB transceivers
- Supports power management
- Operates as a master on the Memory Controller

10.12 USB Device Port

- USB V2.0 full-speed compliant, 12 Mbits per second
- Embedded USB V2.0 full-speed transceiver
- Embedded dual-port RAM for endpoints
- Suspend/Resume logic
- Ping-pong mode (two memory banks) for isochronous and bulk endpoints
- Six general-purpose endpoints
 - Endpoint 0, Endpoint 3: 8 bytes, no ping-pong mode
 - Endpoint 1, Endpoint 2: 64 bytes, ping-pong mode
 - Endpoint 4, Endpoint 5: 256 bytes, ping-pong mode

10.13 Ethernet MAC

- Compatibility with IEEE Standard 802.3

- 10 and 100 Mbits per second data throughput capability
- Full- and half-duplex operation
- MII or RMII interface to the physical layer
- Register interface to address, status and control registers
- DMA interface, operating as a master on the Memory Controller
- Interrupt generation to signal receive and transmit completion
- 28-byte transmit and 28-byte receive FIFOs
- Automatic pad and CRC generation on transmitted frames
- Address checking logic to recognize four 48-bit addresses
- Supports promiscuous mode where all valid frames are copied to memory
- Supports physical layer management through MDIO interface

10.14 Serial Peripheral Interface

- Supports communication with serial external devices
 - Four chip selects with external decoder support allow communication with up to 15 peripherals
 - Serial memories, such as DataFlash and 3-wire EEPROMs
 - Serial peripherals, such as ADCs, DACs, LCD Controllers, CAN Controllers and Sensors
 - External co-processors
- Master or slave serial peripheral bus interface
 - 8- to 16-bit programmable data length per chip select
 - Programmable phase and polarity per chip select
 - Programmable transfer delays between consecutive transfers and between clock and data per chip select
 - Programmable delay between consecutive transfers
 - Selectable mode fault detection
- Connection to PDC channel optimizes data transfers
 - One channel for the receiver, one channel for the transmitter
 - Next buffer support

10.15 Two-wire Interface

- Compatibility with standard two-wire serial memory
- One, two or three bytes for slave address
- Sequential Read/Write operations

10.16 USART

- Programmable Baud Rate Generator
- 5- to 9-bit full-duplex synchronous or asynchronous serial communications
 - 1, 1.5 or 2 stop bits in Asynchronous Mode or 1 or 2 stop bits in Synchronous Mode
 - Parity generation and error detection
 - Framing error detection, overrun error detection

- MSB- or LSB-first
- Optional break generation and detection
- By 8 or by-16 over-sampling receiver frequency
- Optional hardware handshaking RTS-CTS
- Optional modem signal management DTR-DSR-DCD-RI
- Receiver time-out and transmitter timeguard
- Optional Multi-drop Mode with address generation and detection
- RS485 with driver control signal
- ISO7816, T = 0 or T = 1 Protocols for interfacing with smart cards
 - NACK handling, error counter with repetition and iteration limit
- IrDA modulation and demodulation
 - Communication at up to 115.2 Kbps
- Test Modes
 - Remote Loopback, Local Loopback, Automatic Echo
- Connection of two Peripheral DMA Controller (PDC) channels
 - Offers buffer transfer without processor intervention

The USART describes features allowing management of the Modem Signals DTR, DSR, DCD and RI. For details, see [“Modem Mode” on page 434](#).

In the AT91RM9200, only the USART1 implements these signals, named DTR1, DSR1, DCD1 and RI1.

The USART0, USART2 and USART3 do not implement all the modem signals. Only RTS and CTS (RTS0 and CTS0, RTS2 and CTS2, RTS3 and CTS3, respectively) are implemented in these USARTs for other features.

Thus, programming the USART0, USART2 or the USART3 in Modem Mode may lead to unpredictable results. In these USARTs, the commands relating to the Modem Mode have no effect and the status bits relating the status of the modem signals are never activated.

10.17 Serial Synchronous Controller

- Provides serial synchronous communication links used in audio and telecom applications
- Contains an independent receiver and transmitter and a common clock divider
- Interfaced with two PDC channels to reduce processor overhead
- Offers a configurable frame sync and data length
- Receiver and transmitter can be programmed to start automatically or on detection of different event on the frame sync signal
- Receiver and transmitter include a data signal, a clock signal and a frame synchronization signal

10.18 Timer Counter

- Three 16-bit Timer Counter Channels
- Wide range of functions including:
 - Frequency Measurement
 - Event Counting

- Interval Measurement
- Pulse Generation
- Delay Timing
- Pulse Width Modulation
- Up/down Capabilities
- Each channel is user-configurable and contains:
 - Three external clock inputs
 - Five internal clock inputs
 - Two multi-purpose input/output signals
- Internal interrupt signal
- Two global registers that act on all three TC Channels
- The Timer Counter 0 to 5 are described with five generic clock inputs, TIMER_CLOCK1 to TIMER_CLOCK5. In the AT91RM9200, these clock inputs are connected to the Master Clock (MCK), to the Slow Clock (SLCK) and to divisions of the Master Clock. For details, see [“Clock Control” on page 488](#).
[Table 10-6](#) gives the correspondence between the Timer Counter clock inputs and clocks in the AT91RM9200. Each Timer Counter 0 to 5 displays the same configuration.

Table 10-6. Timer Counter Clocks Assignment

TC Clock Input	Clock
TIMER_CLOCK1	MCK/2
TIMER_CLOCK2	MCK/8
TIMER_CLOCK3	MCK/32
TIMER_CLOCK4	MCK/128
TIMER_CLOCK5	SLCK

10.19 MultiMedia Card Interface

- Compatibility with MultiMedia Card Specification Version 2.2
- Compatibility with SD Memory Card Specification Version 1.0
- Cards clock rate up to Master Clock divided by 2
- Embedded power management to slow down clock rate when not used
- Supports two slots
 - One slot for one MultiMedia Card bus (up to 30 cards) or one SD Memory Card
- Support for stream, block and multi-block data read and write
- Connection to a Peripheral DMA Controller (PDC) channel
 - Minimizes processor intervention for large buffer transfers

11. ARM920T Processor Overview

11.1 Overview

The ARM920T cached processor is a member of the ARM9™ Thumb family of high-performance 32-bit system-on-a-chip processors. It provides a complete high performance CPU subsystem including:

- ARM9TDMI RISC integer CPU
- 16-Kbyte instruction and 16-Kbyte data caches
- Instruction and data memory management units (MMUs)
- Write buffer
- AMBA™ (Advanced Microprocessor Bus Architecture) bus interface
- Embedded Trace Macrocell (ETM) interface

The ARM9TDMI core within the ARM920T executes both the 32-bit ARM and 16-bit Thumb instruction sets. The ARM9TDMI processor is a Harvard architecture device, implementing a five-stage pipeline consisting of Fetch, Decode, Execute, Memory and Write stages.

The ARM920T processor incorporates two coprocessors:

- CP14 - Controls software access to the debug communication channel
- CP15 - System Control Processor, providing 16 additional registers that are used to configure and control the caches, the MMU, protection system, clocking mode and other system options

The main features of the ARM920T processor are:

- ARM9TDMI-based, ARM Architecture v4T
- Two Instruction Sets
 - ARM High-performance 32-bit Instruction Set
 - Thumb High Code Density 16-bit Instruction Set
- 5-Stage Pipeline Architecture
 - Instruction Fetch (F)
 - Instruction Decode (D)
 - Execute (E)
 - Data Memory Access (M)
 - Register Write (W)
- 16-Kbyte Data Cache, 16-Kbyte Instruction Cache
 - Virtually-addressed 64-way Associative Cache
 - 8 Words per Line
 - Write-through and Write-back Operation
 - Pseudo-random or Round-robin Replacement
 - Low-power CAM RAM Implementation
- Write Buffer
 - 16-word Data Buffer
 - 4-address Address Buffer
 - Software Control Drain



- Standard ARMv4 Memory Management Unit (MMU)
 - Access Permission for Sections
 - Access Permission for Large Pages and Small Pages Can be Specified Separately for Each Quarter of the Pages
 - 16 Embedded Domains
 - 64-entry Instruction TLB and 64-entry Data TLB
- 8-, 16-, 32-bit Data Bus for Instructions and Data

11.2 Block Diagram

Figure 11-1. ARM920T Internal Functional Block Diagram

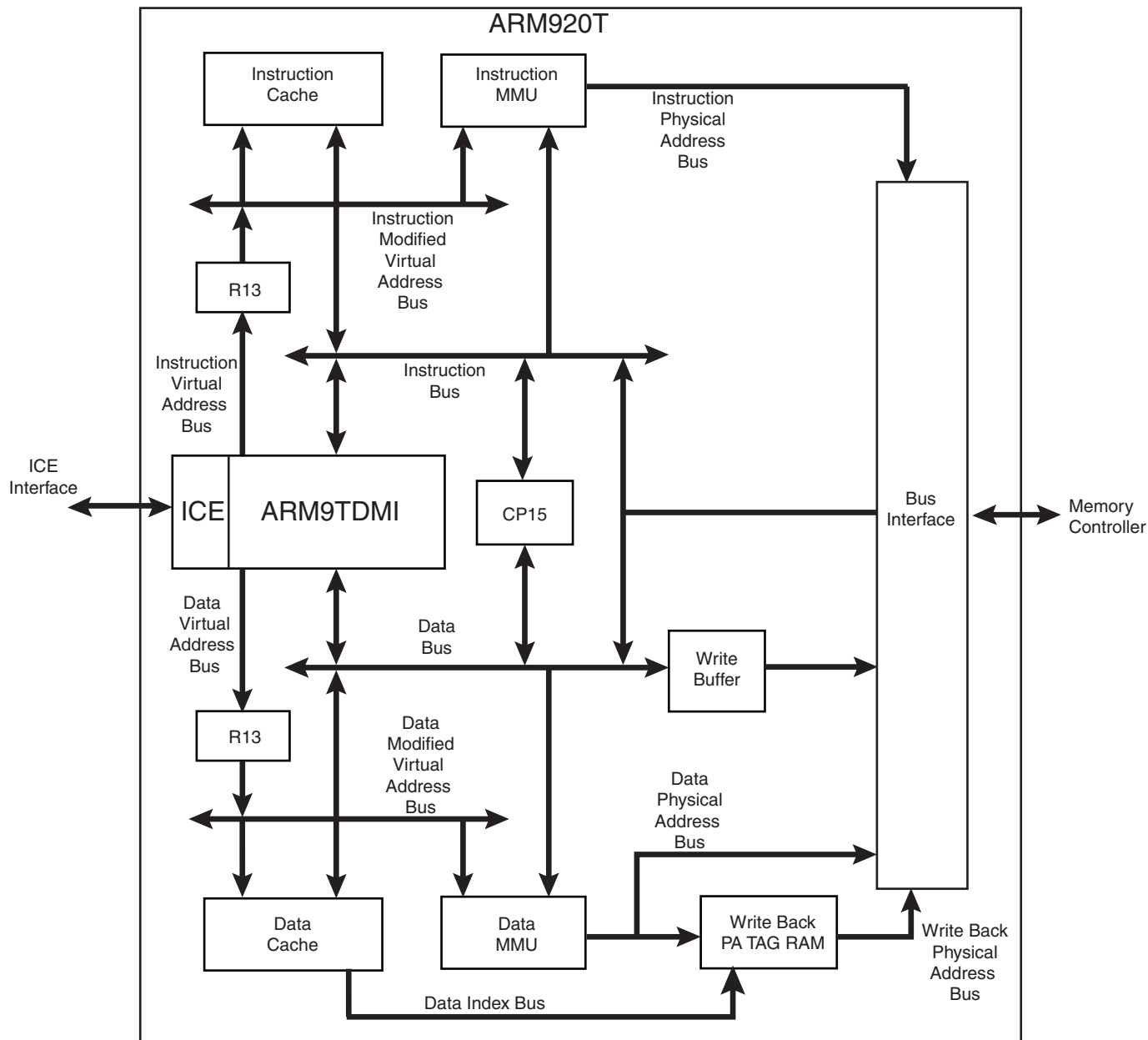

11.3 ARM9TDMI Processor

11.3.1 Instruction Type

Instructions are either 32 bits (in ARM state) or 16 bits (in Thumb state).

11.3.2 Data Types

ARM9TDMI supports byte (8-bit), half-word (16-bit) and word (32-bit) data types. Words must be aligned to four-byte boundaries and half-words to two-byte boundaries.

Unaligned data access behavior depends on which instruction is used in a particular location.

11.3.3 ARM9TDMI Operating Modes

The ARM9TDMI, based on ARM architecture v4T, supports seven processor modes:

- User: Standard ARM program execution state
- FIQ: Designed to support high-speed data transfer or channel processes
- IRQ: Used for general-purpose interrupt handling
- Supervisor: Protected mode for the operating system
- Abort mode: Implements virtual memory and/or memory protection
- System: A privileged user mode for the operating system
- Undefined: Supports software emulation of hardware coprocessors

Mode changes may be made under software control, or may be brought about by external interrupts or exception processing. Most application programs will execute in User Mode. The non-user modes, known as privileged modes, are entered in order to service interrupts or exceptions or to access protected resources.

11.3.4 ARM9TDMI Registers

The ARM9TDMI processor core consists of a 32-bit datapath and associated control logic. That datapath contains 31 general-purpose registers, coupled to a full shifter, Arithmetic Logic Unit and multiplier.

At any one time, 16 registers are visible to the user. The remainder are synonyms used to speed up exception processing.

Register 15 is the Program Counter (PC) and can be used in all instructions to reference data relative to the current instruction.

R14 holds the return address after a subroutine call.

R13 is used (by software convention) as a stack pointer.

Table 11-1. ARM9TDMI Modes and Register Layout

User and System Mode	Supervisor Mode	Abort Mode	Undefined Mode	Interrupt Mode	Fast Interrupt Mode
R0	R0	R0	R0	R0	R0
R1	R1	R1	R1	R1	R1
R2	R2	R2	R2	R2	R2
R3	R3	R3	R3	R3	R3
R4	R4	R4	R4	R4	R4

Table 11-1. ARM9TDMI Modes and Register Layout (Continued)

User and System Mode	Supervisor Mode	Abort Mode	Undefined Mode	Interrupt Mode	Fast Interrupt Mode
R5	R5	R5	R5	R5	R5
R6	R6	R6	R6	R6	R6
R7	R7	R7	R7	R7	R7
R8	R8	R8	R8	R8	R8_FIQ
R9	R9	R9	R9	R9	R9_FIQ
R10	R10	R10	R10	R10	R10_FIQ
R11	R11	R11	R11	R11	R11_FIQ
R12	R12	R12	R12	R12	R12_FIQ
R13	R13_SVC	R13_ABORT	R13_UNDEF	R13_IRQ	R13_FIQ
R14	R14_SVC	R14_ABORT	R14_UNDEF	R14_IRQ	R14_FIQ
PC	PC	PC	PC	PC	PC

CPSR	CPSR	CPSR	CPSR	CPSR	CPSR
	SPSR_SVC	SPSR_ABORT	SPSR_UNDEF	SPSR_IRQ	SPSR_FIQ



Mode-specific banked registers

Registers R0 to R7 are unbanked registers, thus each of them refers to the same 32-bit physical register in all processor modes. They are general-purpose registers, with no special uses managed by the architecture, and can be used wherever an instruction allows a general-purpose register to be specified.

Registers R8 to R14 are banked registers. This means that each of them depends of the current processor mode.

For further details, see the ARM Architecture Reference Manual, Rev. DDI0100E.

11.3.4.1 Modes and Exception Handling

All exceptions have banked registers for R14 and R13.

After an exception, R14 holds the return address for exception processing. This address is used both to return after the exception is processed and to address the instruction that caused the exception.

R13 is banked across exception modes to provide each exception handler with a private stack pointer.

The fast interrupt mode also banks registers 8 to 12 so that interrupt processing can begin without the need to save these registers.

A seventh processing mode, System Mode, does not have any banked registers. It uses the User Mode registers. System Mode runs tasks that require a privileged processor mode and allows them to invoke all classes of exceptions.

11.3.4.2 *Status Registers*

All other processor states are held in status registers. The current operating processor status is in the Current Program Status Register (CPSR). The CPSR holds:

- four ALU flags (Negative, Zero, Carry, and Overflow),
- two interrupt disable bits (one for each type of interrupt),
- one bit to indicate ARM or Thumb execution
- five bits to encode the current processor mode

All five exception modes also have a Saved Program Status Register (SPSR) which holds the CPSR of the task immediately before the exception occurred.

11.3.4.3 *Exception Types*

The ARM9TDMI supports five types of exceptions and a privileged processing mode for each type. The types of exceptions are:

- fast interrupt (FIQ)
- normal interrupt (IRQ)
- memory aborts (used to implement memory protection or virtual memory)
- attempted execution of an undefined instruction
- software interrupt (SWIs)

Exceptions are generated by internal and external sources.

More than one exception can occur at the same time.

When an exception occurs, the banked version of R14 and the SPSR for the exception mode are used to save the state.

To return after handling the exception, the SPSR is moved to the CPSR and R14 is moved to the PC. This can be done in two ways:

- use of a data-processing instruction with the S-bit set, and the PC as the destination
- use of the Load Multiple with Restore CPSR instruction (LDM)

11.3.5 **ARM Instruction Set Overview**

The ARM instruction set is divided into:

- Branch instructions
- Data processing instructions
- Status register transfer instructions
- Load and Store instructions
- Coprocessor instructions
- Exception-generating instructions

ARM instructions can be executed conditionally. Every instruction contains a 4-bit condition code field (bits[31:28]).

For further details, see the ARM920T Technical Reference Manual, Rev. DDI0151C.

Table 11-2 gives the ARM instruction mnemonic list.

Table 11-2. ARM Instruction Mnemonic List

Mnemonic	Operation
MOV	Move
ADD	Add
SUB	Subtract
RSB	Reverse Subtract
CMP	Compare
TST	Test
AND	Logical AND
EOR	Logical Exclusive OR
MUL	Multiply
SMULL	Sign Long Multiply
SMLAL	Signed Long Multiply Accumulate
MSR	Move to Status Register
B	Branch
BX	Branch and Exchange
LDR	Load Word
LDRSH	Load Signed Halfword
LDRSB	Load Signed Byte
LDRH	Load Half Word
LDRB	Load Byte
LDRBT	Load Register Byte with Translation
LDRT	Load Register with Translation
LDM	Load Multiple
SWP	Swap Word
MCR	Move To Coprocessor
LDC	Load To Coprocessor

Mnemonic	Operation
CDP	Coprocessor Data Processing
MVN	Move Not
ADC	Add with Carry
SBC	Subtract with Carry
RSC	Reverse Subtract with Carry
CMN	Compare Negated
TEQ	Test Equivalence
BIC	Bit Clear
ORR	Logical (inclusive) OR
MLA	Multiply Accumulate
UMULL	Unsigned Long Multiply
UMLAL	Unsigned Long Multiply Accumulate
MRS	Move From Status Register
BL	Branch and Link
SWI	Software Interrupt
STR	Store Word
STRH	Store Half Word
STRB	Store Byte
STRBT	Store Register Byte with Translation
STRT	Store Register with Translation
STM	Store Multiple
SWPB	Swap Byte
MRC	Move From Coprocessor
STC	Store From Coprocessor

11.3.6 Thumb Instruction Set Overview

The Thumb instruction set is a re-encoded subset of the ARM instruction set.

The Thumb instruction set is divided into:

- Branch instructions
- Data processing instructions
- Load and Store instructions
- Load and Store multiple instructions
- Exception-generating instruction

In Thumb mode, eight general-purpose registers are available, R0 to R7, that are the same physical registers as R0 to R7 when executing ARM instructions. Some Thumb instructions also access the Program Counter (ARM Register 15), the Link Register (ARM Register 14) and the

Stack Pointer (ARM Register 13). Further instructions allow limited access to the ARM register 8 to 15.

For further details, see the ARM920T Technical Reference Manual, Rev. DDI0151C.

Table 11-3 gives the Thumb instruction mnemonic list.

Table 11-3. Thumb Instruction Mnemonic List

Mnemonic	Operation
MOV	Move
ADD	Add
SUB	Subtract
CMP	Compare
TST	Test
AND	Logical AND
EOR	Logical Exclusive OR
LSL	Logical Shift Left
ASR	Arithmetic Shift Right
MUL	Multiply
B	Branch
BX	Branch and Exchange
LDR	Load Word
LDRH	Load Half Word
LDRB	Load Byte
LDRSH	Load Signed Halfword
LDMIA	Load Multiple
PUSH	Push Register to stack

Mnemonic	Operation
MVN	Move Not
ADC	Add with Carry
SBC	Subtract with Carry
CMN	Compare Negated
NEG	Negate
BIC	Bit Clear
ORR	Logical (inclusive) OR
LSR	Logical Shift Right
ROR	Rotate Right
BL	Branch and Link
SWI	Software Interrupt
STR	Store Word
STRH	Store Half Word
STRB	Store Byte
LDRSB	Load Signed Byte
STMIA	Store Multiple
POP	Pop Register from stack

11.4 CP15 Coprocessor

Coprocessor 15, or System Control Coprocessor CP15, is used when special features are used with the ARM9TDMI such as:

- On-chip Memory Management Unit (MMU)
- Instruction and/or Data Cache
- Write buffer

To control these features, CP15 provides 16 additional registers. See [Table 11-4](#).

Table 11-4. CP15 Registers

Register	Name	Access
0	ID Register	Read-only
1	Control	Read/Write
2	Translation Table Base	Read/Write
3	Domain Access Control	Read/Write
4	Reserved	None
5	Fault Status	Read/Write
6	Fault Address	Read/Write
7	Cache Operations	Write-only
8	TLB ⁽¹⁾ Operations	Write-only
9	cache lockdown	Read/Write
10	TLB lockdown	Read/Write
11	Reserved	None
12	Reserved	None
13	FCSE PID ⁽²⁾	Read/Write
14	Reserved	None
15	Test configuration	None

Notes: 1. TLB: Translation Lookaside Buffer

2. FCSE PID: Fast Context Switch Extension Process Identifier

11.4.1 CP15 Register Access

CP15 registers can only be accessed in privileged mode by:

- MCR (Move to Coprocessor from ARM Register) instruction
- MRC (Move to ARM Register from Coprocessor) instruction

Other instructions (CDP, LDC, STC) cause an undefined instruction exception.

The MCR instruction is used to write an ARM register to CP15.

The MRC instruction is used to read the value of CP15 to an ARM register.

The assembler code for these instructions is:

```
MCR/MRC{cond} p15, opcode_1, Rd, CRn, CRm, opcode_2.
```

The MCR, MRC instructions bit pattern is shown below:

31	30	29	28	27	26	25	24
Cond				1	1	1	0
23	22	21	20	19	18	17	16
opcode_1			L	CRn			
15	14	13	12	11	10	9	8
Rd				1	1	1	1
7	6	5	4	3	2	1	0
opcode_2			1	CRm			

- **CRm[3:0]: Specified Coprocessor Action**

Determines specific coprocessor action. Its value is dependent on the CP15 register used. For details, refer to CP15 specific register behavior.

- **opcode_2[7:5]**

Determines specific coprocessor operation code. By default, set to 0.

- **Rd[15:12]: ARM Register**

Defines the ARM register whose value is transferred to the coprocessor. If R15 is chosen, the result is unpredictable.

- **CRn[19:16]: Coprocessor Register**

Determines the destination coprocessor register.

- **opcode_1[23:20]: Coprocessor Code**

Defines the coprocessor specific code. Value is c15 for CP15.

- **L: Instruction Bit**

0 = MCR instruction

1 = MRC instruction

- **Cond [31:28]: Condition**

11.5 Memory Management Unit (MMU)

The ARM920T processor implements an enhanced ARM architecture v4 MMU to provide translation and access permission checks for the instruction and data address ports of the ARM9TDMI core. The MMU is controlled from a single set of two-level page tables stored in the main memory, providing a single address and translation protection scheme. Independently, instruction and data TLBs in the MMU can be locked and flushed.

Table 11-5. Mapping Details

Mapping Name	Mapping Size	Access Permission By	Subpage Size
Section	1M byte	Section	-
Large Page	64K bytes	4 separated subpages	16K bytes
Small Page	4K bytes	4 separated subpages	1K byte
Tiny Page	1K byte	Tiny Page	-

11.5.1 Domain

A domain is a collection of sections and pages. The ARM920T supports 16 domains. Access to the domains is controlled by the Domain Access Control register. For details, refer to [“CP15 Register 3, Domain Access Control Register” on page 50](#).

11.5.2 MMU Faults

The MMU generates alignment faults, translation faults, domain faults and permission faults. Alignment fault checking is not affected by whether the MMU is enabled or not.

The access controls of the MMU detect the conditions that produce these faults. If the fault is a result of memory access, the MMU aborts the access and signals the fault to the CPU core. The MMU stores the status and address fault in the FSR and FAR registers (only for faults generated by data access).

The MMU does not store fault information about faults generated by an instruction fetch.

The memory system can abort during line fetches, memory accesses and translation table access.

11.6 Caches, Write Buffers and Physical Address

The ARM920T includes an Instruction Cache (ICache), a Data Cache (DCache), a write buffer and a Physical Address (PA) TAG RAM to reduce the effect on main memory bandwidth and latency performance.

The ARM920T implements separate 16-Kbyte Instruction and 16-Kbyte Data Caches.

The caches and the write buffer are controlled by the CP15 Register 1 (Control), CP15 Register 7 (Cache Operations) and CP15 Register 9 (Cache Lockdown).

11.6.1 Instruction Cache (ICache)

The ARM920T includes a 16-Kbyte Instruction Cache (ICache). The ICache has 512 lines of 32 bytes, arranged as a 64-way set associative cache.

Instruction access is subject to MMU permission and translation checks.

If the ICache is enabled with the MMU disabled, all instructions fetched as threats are cachable. No protection checks are made and the physical address is flat-mapped to the modified virtual address.

When the ICache is disabled, the cache contents are ignored and all instruction fetches appear on the AMBA bus.

On reset, the ICache entries are invalidated and the ICache is disabled. For best performance, ICache should be enabled as soon as possible after reset.

The ICache is enabled by writing 1 to I bit of the CP15 Register 1 and disabled by writing 0 to this bit. For more details, see [“CP15 Register 1, Control” on page 48](#).

The ICache is organized as eight segments, each containing 64 lines with each line made up of 8 words. The position of the line within the segment is called the index and is numbered from 0 to 63.

A line in the cache is identified by the index and segment. The index is independent of the MVA (Modified Virtual Address), and the segment is the bit[7:5] of the MVA.

11.6.2 Data Cache (DCache) and Write Buffer

The ARM920T includes a 16-Kbyte data cache (DCache). The DCache has 512 lines of 32 bytes, arranged as a 64-way set associative cache, and uses MVAs translated by CP15 Register 13 from the ARM9DTMI core.

11.6.2.1 DCache

The DCache is organized as eight segments, each containing 64 lines with each line made up of eight words. The position of the line within the segment is called the index and is a number from 0 to 63.

The Write Buffer can hold up to 16 words of data and four separate addresses.

DCache and Write Buffer operations are closely connected as their configuration is set in each section by the page descriptor in the MMU translation table.

All data accesses are subject to MMU permission and translation checks. Data accesses aborted by the MMU cannot cause linefill or data access via the AMBA ASB interface.

Write-through Operation When a cache hit occurs for a data access, the cache line that contains the data is updated to contain its value. The new data is also immediately written to the main memory.

Write-back Operation When a cache hit occurs for a data access, the cache line is marked as dirty, meaning that its contents are not up-to-date with those in the main memory.

11.6.2.2 *Write Buffer*

The ARM920T incorporates a 16-entry write buffer to avoid stalling the processor when writes to external memory are performed. When a store occurs, its data, address and other details are written to the write buffer at high speed. The write buffer then completes the store at the main memory speed (typically slower than the ARM speed). In parallel, the ARM9TDMI processor can execute further instructions at full speed.

11.6.2.3 *Physical Address Tag RAM (PA TAG RAM)*

The ARM920T implements Physical Address Tag RAM (PA TAG RAM) to perform write-backs from the data cache. The physical address of all the lines held in the data cache is stored in the PA TAG memory, removing the need for address translation when evicting a line from the cache.

When a line is written into the data cache, the physical address TAG is written into the PA TAG RAM. If this line has to be written back to the main memory, the PA TAG RAM is read and the physical address is used by the AMBA ASB interface to perform the write-back.

For a 16-Kbyte DCache, the PA TAG RAM is organized by eight segments with:

- 64 rows per segments
- 26 bits per rows
- be

11.7 ARM920T User Interface

11.7.1 CP15 Register 0, ID Code and Cache Type

Access: Read-only

The CP Register 0 contains specific hardware information. The contents of the read accesses are determined by the opcode_2 field value. Writing to Register 0 is unpredictable.

11.7.1.1 ID Code

The ID code register is accessed by reading the register 0 with the opcode_2 field set to 0.

The contents of the ID code is shown below:

31	30	29	28	27	26	25	24
imp							
23	22	21	20	19	18	17	16
SRev				archi			
15	14	13	12	11	10	9	8
PNumber							
7	6	5	4	3	2	1	0
				Layout Rev			

- **LayoutRev[3:0]: Revision**

Contains the processor revision number

- **PNumber[15:4]: Processor Part Number**

0x920 value for ARM920T processor.

- **archi[19:16]: Architecture**

Details the implementor architecture code.

0x2 value means ARMv4T architecture.

- **SRev[23:20]: Specification Revision Number**

0x1 value; specification revision number used to distinguished two variants of the same primary part.

- **imp[31:24]: Implementor Code**

0x41 (= A); means ARM Ltd.

11.7.1.2 Cache Type

The Cache Type register is accessed by reading the register 0 with the opcode_2 field set to 1.

The Cache Type register contains information about the size and architecture of the caches.

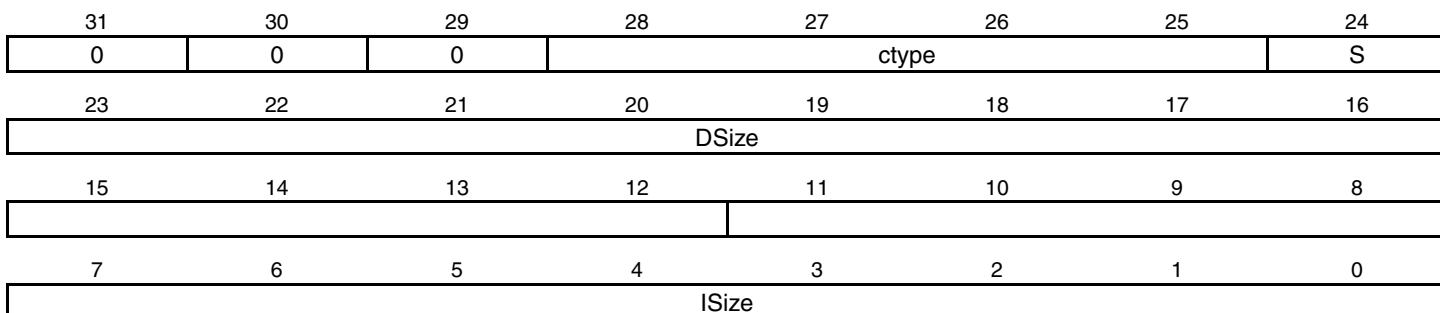

- **ISize[11:0]: Instruction Cache Size**

Indicates the size, line length and associativity of the instruction cache.

- **DSize[23:12]: Data Cache Size**

Indicates the size, line length and associativity of the data cache.

- **S[24]: Cache**

Indicates if the cache is unified or has separate instruction and data caches.

Set to 1, this field indicates separate Instruction and Data caches.

- **ctype[28:25]: Cache Type**

Defines the cache type.

For details on bits DSize and ISize, refer to the ARM920T Technical Reference Manual, Rev. DDI0151C.

11.7.2 CP15 Register 1, Control

Access: Read/Write

The CP15 Register 1, or Control Register, contains the control bits of the ARM920T.

31	30	29	28	27	26	25	24
iA	nF	-	-	-	-	-	-
23	22	21	20	19	18	17	16
-	-	-	-	-	-	-	-
15	14	13	12	11	10	9	8
-	RR	V	I	0	0	R	S
7	6	5	4	3	2	1	0
B	1	1	1	1	C	A	M

- **M[0]: MMU Enable**

0 = MMU disabled.

1 = MMU enabled.

- **A[1]: Alignment Fault Enable**

0 = Fault checking disabled.

1 = Fault checking enabled.

- **C[2]: DCache Enable**

0 = DCache disabled.

1 = DCache enabled.

- **B[7]: Endianness**

0 = Little endian mode.

1 = Big endian mode.

- **S[8]: System Protection**

Modifies the MMU protection system.

For further details, see the ARM920T Technical Reference Manual, Rev. DDI0151C.

- **R[9]: ROM Protection**

Modifies the MMU protection system.

For further details, see the ARM920T Technical Reference Manual, Rev. DDI0151C.

- **I[12]: ICache Control**

0 = ICache disabled.

1 = ICache enabled.

- **V[13]: Base Location of Exception Register**

0 = Low address means 0x00000000.

1 = High address means 0xFFFF0000.

- **RR[14]: Round Robin Replacement**

0 = Random replacement.

1 = Round robin replacement.

- **Clocking Mode[31:30] (iA and nF bits)**

iA	nF	Clocking mode
0	0	Fast Bus
0	1	Synchronous
1	0	Reserved
1	1	Asynchronous

11.7.3 CP15 Register 2, TTB

Access: Read/Write

The CP15 Register 2, or Translation Table Base (TTB) Register, defines the first-level translation table.

31	30	29	28	27	26	25	24
Pointer							
23	22	21	20	19	18	17	16
Pointer							
15	14	13	12	11	10	9	8
Pointer		-	-	-	-	-	-
7	6	5	4	3	2	1	0
-	-	-	-	-	-	-	-

- **Pointer[31:14]**

Points to the first-level translation table base. Read returns the currently active first-level translation table. Write sets the pointer to the first-level table to the written value.

The non-defined bits should be zero when written and are unpredictable when read.

11.7.4 CP15 Register 3, Domain Access Control Register

Access: Read/Write

The CP 15 Register 3, or Domain Access Control Register, defines the domain's access permission.

MMU accesses are priority controlled through the use of 16 domains.

Each field of Register 3 is associated with one domain.

31	30	29	28	27	26	25	24
D15		D14		D13		D12	
23	22	21	20	19	18	17	16
D11		D10		D9		D8	
15	14	13	12	11	10	9	8
D7		D6		D5		D4	
7	6	5	4	3	2	1	0
D3		D2		D1		D0	

- **D15 to D0: Named Domain Access**

The 2-bit field value allows domain access as described in the table below.

Value		Access	Description
0	0	No access	Any access generates a domain fault
0	1	Client	The Users of domain (execute programs, access data), the domain access permission controlled the domain access.
1	0	Reserved	Reserved
1	1	Manager	Controls the behavior of the domain, no checking of the domain access permission is done

11.7.5 CP15 Register 4, Reserved

Any access (Read or Write) to this register causes unpredictable behavior.

11.7.6 CP15 Register 5, Fault Status Register

Access: Read/Write

Reading the CP 15 Register 5, or Fault Status Register (FSR), returns the source of the last data fault, indicating the domain and type of access being attempted when the data abort occurred.

In addition, the virtual address which caused the data abort is written into the Fault Address Register (CP15 Register 6).

Writing the CP 15 Register 5, or Fault Status Register (FSR), sets the FSR to the value of the data written. This is useful for a debugger to restore the value of the FSR.

31	30	29	28	27	26	25	24
-	-	-	-	-	-	-	-
23	22	21	20	19	18	17	16
-	-	-	-	-	-	-	-
15	14	13	12	11	10	9	8
-	-	-	-	-	-	-	-
7	6	5	4	3	2	1	0
Domain				Status			

- **Status[3:0]: Fault Type**

Indicates the fault type. The status field is encoded by the MMU when a data abort occurs. The interpretation of the Status field is dependant on the domain field and the MVA associated with the data abort (stored in the FAR).

- **Domain[7:4]: Domain**

Indicates the domain (D15 - D0) being accessed when the fault occurred.

The non-defined bits should be zero when written and are unpredictable when read.

11.7.7 CP15 Register 6, Fault Address Register

Access: Read/Write

The CP 15 Register 6, or Fault Address Register (FAR), contains the MVA (Modified Virtual Address) of the access being attempted when the last fault occurred. The FAR is only updated for data faults, not for prefetch faults.

The ability to write to the FAR is provided to allow a debugger to restore a previous state.

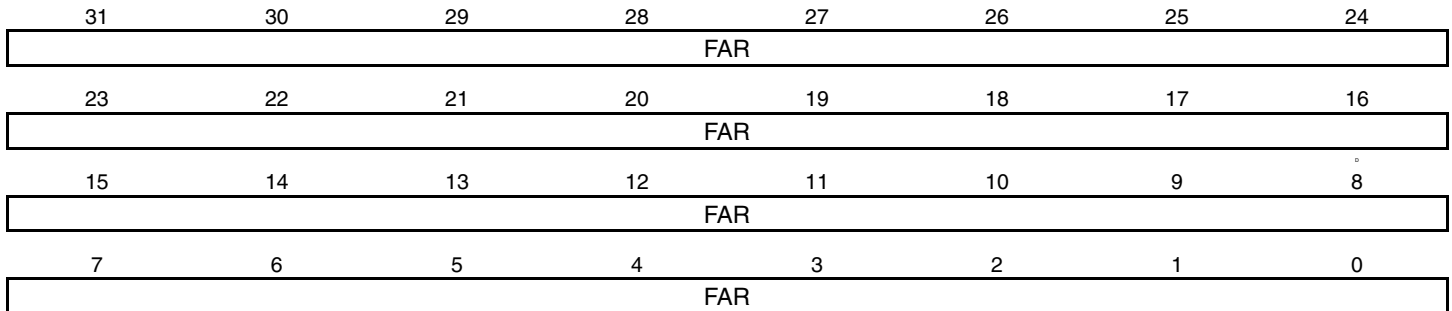

- **FAR[31:0]: Fault Address**

On reading: returns the value of the FAR. The FAR holds the virtual address of the access which was attempted when fault occurred.

On writing: sets the FAR to the value of the written data. This is useful for a debugger to restore the value of the FAR.

11.7.8 CP15 Register 7, Cache Operation Register

Access: Write-only

The CP15 Register 7, or Cache Operation Register, is used to manage the Instruction Cache (ICache) and the Data Cache (DCache).

The function of each cache operation is selected by the opcode_2 and CRm fields in the MCR instruction used to write CP15 Register 7.

Table 11-6. Cache Functions

Function	Data	CRm	opcode_2
Wait for Interrupt	SBZ	c0	4
Invalidate ICache	SBZ	c5	0
Invalidate ICache single entry (using MVA)	MVA format	c5	1
Invalidate DCache	SBZ	c6	0
Invalidate DCache single entry (using MVA)	MVA format	c6	1
Invalidate ICache and DCache	SBZ	c7	0
Clean DCache single entry (using MVA)	MVA format	c10	1
Clean DCache single entry (using index)	Index format	c10	2
Drain write buffer	SBZ	c10	4
Prefetch ICache line (using MVA)	MVA format	c13	1
Clean and Invalidate DCache entry (using MVA)	MVA format	c14	1
Clean and Invalidate DCache entry (using index)	Index format	c14	2

Function Details

- Wait for interrupt

Stops execution in low-power state until an interrupt occurs.

- Invalidate

The cache line (or lines) is marked as invalid, so no cache hits occur in that line until it is re-allocated to an address.

- Clean

Applies to write-back data caches. If the cache line contains stored data that has not yet been written out to the main memory, it is written to main memory immediately.

- Drain write buffer

Stops the execution until all data in the write buffer has been stored in the main memory.

- Prefetch

The memory cache line at the specified virtual address is loaded into the cache.

The operation carried out on a single cache line identifies the line using the data transferred in the MCR instruction.

The data is interpreted as using one of the two formats:

- MVA format
- index format

Below are the details of CP15 Register 7, or Cache Function Register, in MVA format.

31	30	29	28	27	26	25	24
mva							
23	22	21	20	19	18	17	16
mva							
15	14	13	12	11	10	9	8
mva							
7	6	5	4	3	2	1	0
mva			-	-	-	-	-

- **mva[31:5]: Modified Virtual Address**

The non-defined bits should be zero when written and are unpredictable when read.

Below the details of CP15 Register 7, or Cache Function Register, in Index format:

31	30	29	28	27	26	25	24
index						-	-
23	22	21	20	19	18	17	16
-	-	-	-	-	-	-	-
15	14	13	12	11	10	9	8
-	-	-	-	-	-	-	-
7	6	5	4	3	2	1	0
set			-	-	-	-	-

- **index[31:26]: Line**

Determines the cache line.

- **set[7:5]: Segment**

Determines the cache segment.

The non-defined bits should be zero when written and are unpredictable when read.

Writing other opcode_2 values or CRm values is unpredictable.

Reading from CP15 Register 7 is unpredictable.

11.7.9 CP15 Register 8, TLB Operations Register

Access: Write-only

The CP15 Register 8, or Translation Lookaside Buffer (TLB) Operations Register, is used to manage instruction TLBs and data TLBs.

The TLB operation is selected by opcode_2 and CRm fields in the MCR instruction used to write CP15 Register 8.

Table 11-7. TLB Operations

Function	Data	CRm	opcode_2
Invalidate I TLB	SBZ	5	0
Invalidate I TLB single entry (using MVA)	MVA format	5	1
Invalidate D TLB	SBZ	6	0
Invalidate D TLB single entry (using MVA)	MVA format	6	1
Invalidate both Instruction and Data TLB	SBZ	7	

Below are details of the CP15 Register 8 for TLB operation on MVA format and one single entry.

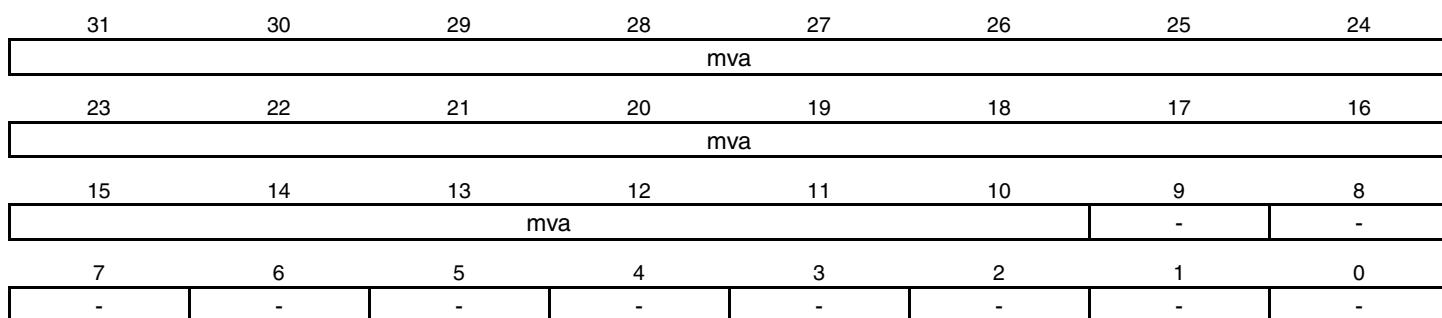

- **mva[31:10]: Modified Virtual Address**

The non-defined bits should be zero when written and are unpredictable when read.

Writing other opcode_2 values or CRm values is unpredictable.

Reading from CP15 Register 8 is unpredictable.

11.7.10 CP15 Register 9, Cache Lockdown Register

Access: Read/Write

The CP15 Register 9, or Cache Lockdown Register, is 0x0 on reset. The Cache Lockdown Register allows software to control which cache line in the ICache or DCache is loaded for a linefill. It prevents lines in the ICache or DCache from being evicted during a linefill, locking them into the cache.

Reading from the CP15 Register 9 returns the value of the Cache Lockdown Register that is the base pointer for all cache segments.

Only the bits[31:26] are returned; others are unpredictable.

Writing to the CP15 Register 9 updates the Cache Lockdown Register with both the base and the current victim pointers for all cache segments.

Table 11-8. Cache Lockdown Functions

Function	Data	CRm	opcode_2
Read DCache lockdown base	Base	0	0
Write DCache victim and lockdown base	Victim = Base	0	0
Read ICache lockdown base	Base	0	1
Write ICache victim and lockdown base	Victim = Base	0	1

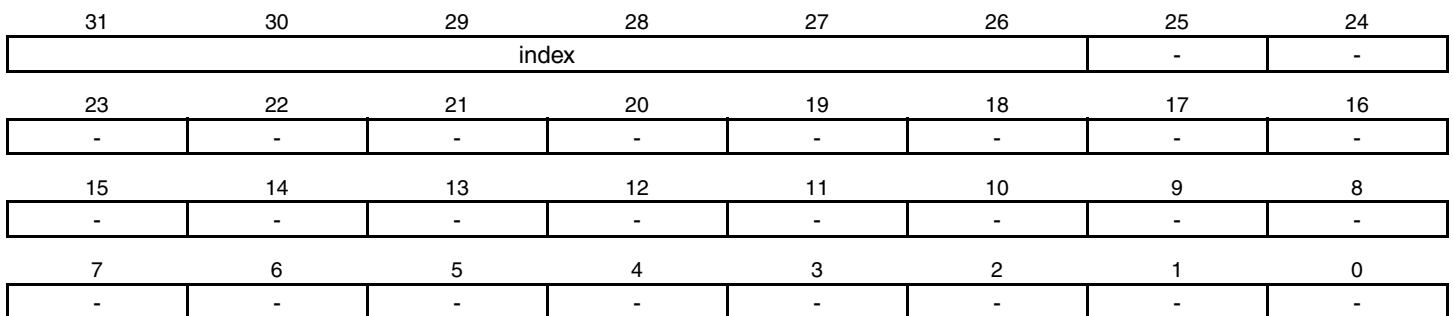

- **index[31:26]: Victim Pointer**

Current victim pointer that specifies the cache line to be used as victim for the next linefill.

The non-defined bits should be zero when written and are unpredictable when read.

11.7.11 CP15 Register 10, TLB Lockdown Register

Access: Read/Write

The CP15 Register 10, or TLB Lockdown Register, is 0x0 on reset. There is a TLB Lockdown Register for each of the TLBs; the value of opcode_2 determines which TLB register to access:

- opcode_2 = 0x0 for D TLB register
- opcode_2 = 0x1 for I TLB register

Table 11-9. TLB Lockdown Functions

Function	Data	CRm	Opcode_2
Read D TLB lockdown	TLB lockdown	0	0
Write D TLB lockdown	TLB lockdown	0	0
Read I TLB lockdown	TLB lockdown	0	1
Write I TLB lockdown	TLB lockdown	0	1

31	30	29	28	27	26	25	24
Base							
23	22	21	20	19	18	17	16
Victim				-	-	-	-
15	14	13	12	11	10	9	8
-	-	-	-	-	-	-	-
7	6	5	4	3	2	1	0
-	-	-	-	-	-	-	P

- **Base[31:26]: Base**

The TLB replacement strategy only uses the TLB entries numbered from base to 63. The Victim field provided is in that range.

- **Victim[25:20]: Victim Counter**

Specifies the TLB entry (line) being overwritten.

- **P[0]: Preserved**

If 0, the TLB entry can be invalidated.

If 1, the TLB entry is protected. It cannot be invalidated during the Invalidate All instruction. Refer to [“CP15 Register 8, TLB Operations Register” on page 55](#).

The non-defined bits should be zero when written and are unpredictable when read.

11.7.12 CP15 Registers 11, 12, Reserved

Any access (Read or Write) to these registers causes unpredictable behavior.

11.7.13 CP15 Register 13, FCSE PID Register

Access: Read/Write

The CP15 Register 13, or Fast Context Switch Extension (FCSE) Process Identifier (PID) Register, is set to 0x0 on reset.

Reading from CP15 Register 13 returns the FCSE PID value.

Writing to CP15 Register 13 sets the FCSE PID.

The FCSE PID sets the mapping between the ARM9TDMI and the MMU of the cache memories.

The addresses issued by the ARM9TDMI are in the range of 0 to 32 Mbytes and are translated via the FCSE PID.

31	30	29	28	27	26	25	24
FCSEPID							-
23	22	21	20	19	18	17	16
-	-	-	-	-	-	-	-
15	14	13	12	11	10	9	8
-	-	-	-	-	-	-	-
7	6	5	4	3	2	1	0
-	-	-	-	-	-	-	-

- **FCSEPID[31:25]: FCSE PID**

The FCSE PID modifies the behavior of the of the ARM920T memory system. This modification allows multiple programs to run on the ARM.

The 4-GB virtual address is divided into 128 process blocks of 32 Mbytes each. Each process block can contain a program that has been compiled to use the address range 0x00000000 to 0x01FFFFFF. For each $i = 0$ to 127 process blocks, i runs from address $i * 0x20000000$ to address $i * 0x20000000 + 0x01FFFFFF$.

For further details, see the ARM920T Technical Reference Manual, Rev. DDI0151C.

The non-defined bits should be zero when written and are unpredictable when read.

11.7.14 CP15 Register 14, Reserved

Any access (Read or Write) of these registers causes unpredictable behavior.

11.7.15 CP15 Register 15, Test Configuration Register

CP15 Register 15, or Test Configuration Register, is used for test purposed. Any access (write or read) to this register causes unpredictable behavior.

12. Debug and Test Features (DBG Test)

12.1 Overview

The AT91RM9200 features a number of complementary debug and test capabilities. A common JTAG/ICE (In-Circuit Emulator) port is used for standard debugging functions such as downloading code and single-stepping through programs. An ETM (Embedded Trace Macrocell) provides more sophisticated debug features such as address and data comparators, half-rate clock mode, counters, sequencer and FIFO. The Debug Unit provides a two-pin UART that can be used to upload an application into internal SRAM. It manages the interrupt handling of the internal COMMTX and COMMRX signals that trace the activity of the Debug Communication Channel.

A set of dedicated debug and test input/output pins give direct access to these capabilities from a PC-based test environment.

Features of Debug and Test Features are:

- Integrated Embedded In-Circuit-Emulator
- Debug Unit
 - Two-pin UART
 - Debug Communication Channel
 - Chip ID Register
- Embedded Trace Macrocell: ETM9 Rev2a
 - Medium Level Implementation
 - Half-rate Clock Mode
 - Four Pairs of Address Comparators
 - Two Data Comparators
 - Eight Memory Map Decoder Inputs
 - Two Counters
 - One Sequencer
 - One 18-byte FIFO
- IEEE1149.1 JTAG Boundary Scan on all Digital Pins

12.2 Block Diagram

Figure 12-1. AT91RM9200 Debug and Test Block Diagram

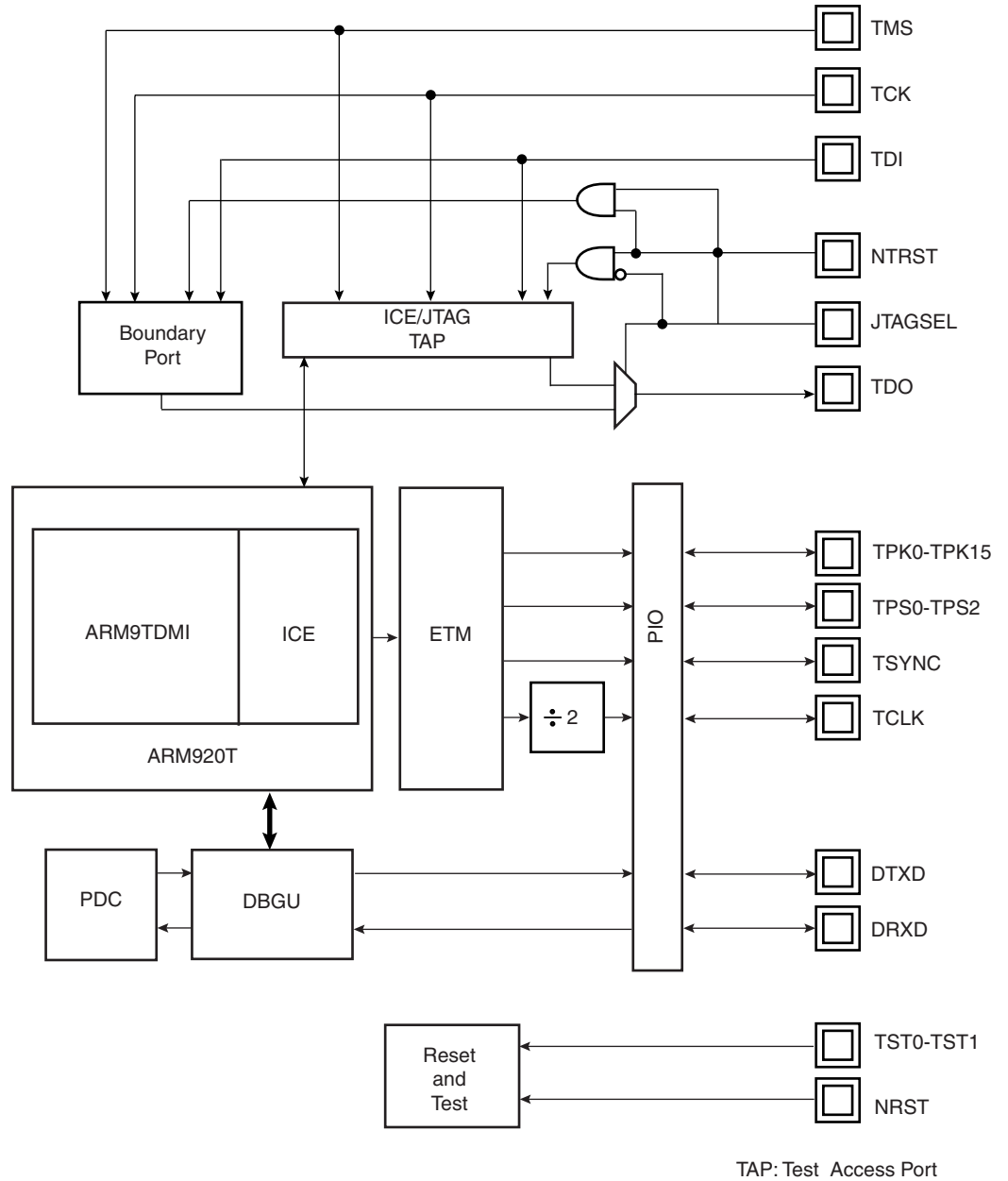

12.3 Application Examples

12.3.1 Debug Environment

Figure 12-2 on page 61 shows a complete debug environment example. The ICE/JTAG interface is used for standard debugging functions such as downloading code and single-stepping through the program. The Trace Port interface is used for tracing information. A software debugger running on a personal computer provides the user interface for configuring a Trace Port interface utilizing the ICE/JTAG interface.

Figure 12-2. AT91RM9200-based Application Debug and Trace Environment Example

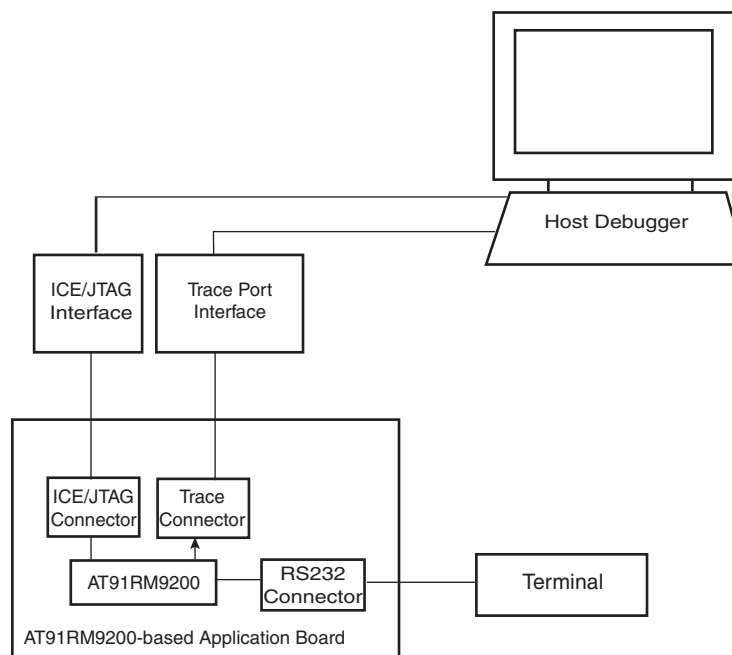

12.4 Test Environment

Figure 12-3 below shows a test environment example. Test vectors are sent and interpreted by the tester. In this example, the “board under test” is designed using many JTAG compliant devices. These devices can be connected together to form a single scan chain.

Figure 12-3. AT91RM9200-based Application IEEE1149.1 Test Environment Example

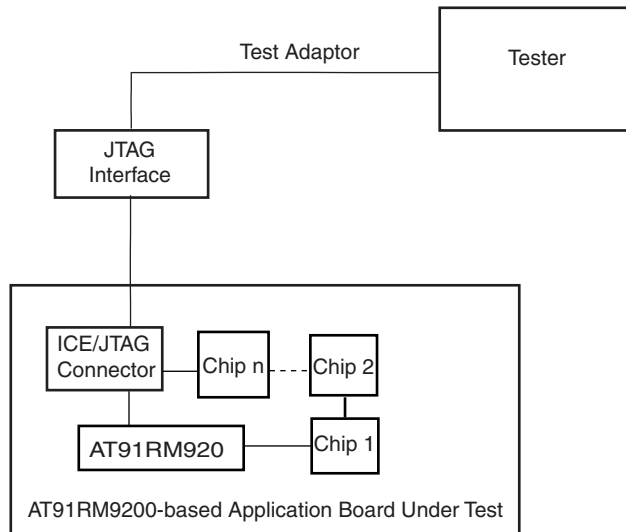

12.5 Debug and Test Pin Description

Table 12-1. Debug and Test Pin List

Pin Name	Function	Type	Active Level
Reset/Test			
NRST	Microcontroller Reset	Input	Low
TST0	Test Mode Select	Input	
TST1	Test Mode Select	Input	
ICE and JTAG			
TCK	Test Clock	Input	
TDI	Test Data In	Input	
TDO	Test Data Out	Output	
TMS	Test Mode Select	Input	
NTRST	Test Reset Signal	Input	Low
JTAGSEL	JTAG Selection	Input	
ETM (available only in BGA package)			
TSYNC	Trace Synchronization Signal	Output	
TCLK	Trace Clock	Output	
TPS0- TPS2	Trace ARM Pipeline Status	Output	
TPK0 - TPK15	Trace Packet Port	Output	
Debug Unit			
DRXD	Debug Receive Data	Input	DRXD
DTXD	Debug Transmit Data	Output	DTXD

12.6 Functional Description

12.6.1 Test Mode Pins

Two dedicated pins (TST1, TST0) are used to define the test mode of the device. The user must make sure that these pins are both tied at low level to ensure normal operating conditions. Other values associated to these pins are manufacturing test reserved.

12.6.2 Embedded In-Circuit Emulator

The ARM9TDMI Embedded In-Circuit Emulator is supported via the ICE/JTAG port. It is connected to a host computer via an ICE interface. Debug support is implemented using an ARM9TDMI core embedded within the ARM920T. The internal state of the ARM920T is examined through an ICE/JTAG port which allows instructions to be serially inserted into the pipeline of the core without using the external data bus. Therefore, when in debug state, a store-multiple (STM) can be inserted into the instruction pipeline. This exports the contents of the ARM9TDMI registers. This data can be serially shifted out without affecting the rest of the system.

There are six scan chains inside the ARM920T processor which support testing, debugging, and programming of the Embedded ICE. The scan chains are controlled by the ICE/JTAG port.

Embedded ICE mode is selected when JTAGSEL is low. It is not possible to switch directly between ICE and JTAG operations. A chip reset must be performed (NRST and NTRST) after JTAGSEL is changed. The test reset input to the embedded ICE (NTRST) is provided separately to facilitate debug of the boot program.

For further details on the Embedded In-Circuit-Emulator, see the ARM920T Technical Reference Manual, ARM Ltd, - DDI 0151C.

12.6.3 Debug Unit

The Debug Unit provides a two-pin (DXRD and TXRD) UART that can be used for several debug and trace purposes and offers an ideal means for in-situ programming solutions and debug monitor communication. Moreover, the link with two Peripheral DMA Controller channels provides packet handling of these tasks with processor time reduced to a minimum.

The Debug Unit also manages the interrupt handling of the COMMTX and COMMRX signals that come from the ICE and trace the activity of the Debug Communication Channel.

The Debug Unit can be used to upload an application into internal SRAM. It is activated by the boot program when no valid application is detected.

A specific register, the Debug Unit Chip ID Register, informs about the product version and its internal configuration.

The AT91RM9200 Debug Unit Chip ID value is: 0x09290781, on 32-bit width.

For further details on the Debug Unit, see [“Debug Unit \(DBGU\)” on page 321](#).

For further details on the Debug Unit and the Boot program, see [“Boot Program” on page 83](#).

12.6.4 Embedded Trace Macrocell

The AT91RM9200 features an Embedded Trace Macrocell (ETM), which is closely connected to the ARM9TDMI Processor. The Embedded Trace is a standard mid-level implementation and contains the following resources:

- Four pairs of address comparators
- Two data comparators

- Eight memory map decoder inputs
- Two counters
- One sequencer
- Four external inputs
- One external output
- One 18-byte FIFO

The Embedded Trace Macrocell of the AT91RM9200 works in half-rate clock mode and thus integrates a clock divider. This assures that the maximum frequency of all the trace port signals do not exceed one half of the ARM920T clock speed.

The Embedded Trace Macrocell input and output resources are not used in the AT91RM9200.

The Embedded Trace is a real-time trace module with the capability of tracing the ARM9TDMI instruction and data.

The Embedded Trace debug features are only accessible in the AT91RM9200 BGA package.

For further details on Embedded Trace Macrocell, see the ETM9 (Rev2a) Technical Reference Manual, ARM Ltd. -DDI 0157E.

12.6.4.1 Trace Port

The Trace Port is made up of the following pins:

- TSYNC - the synchronization signal (Indicates the start of a branch sequence on the trace packet port.)
- TCLK - the Trace Port clock, half-rate of the ARM920T processor clock.
- TPS0 to TPS2 - indicate the processor state at each trace clock edge.
- TPK0 to TPK15 - the Trace Packet data value.

The trace packet information (address, data) is associated with the processor state indicated by TPS. Some processor states have no additional data associated with the Trace Packet Port (i.e. failed condition code of an instruction). The packet is 8-bits wide, and up to two packets can be output per cycle.

Figure 12-4. ETM9 Block

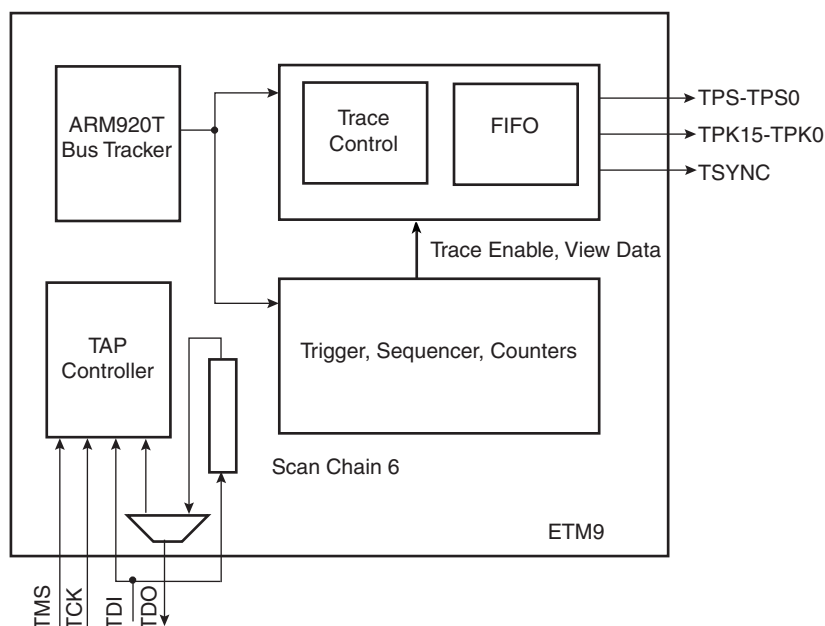

12.6.4.2 Implementation Details

This section gives an overview of the Embedded Trace resources. For further details, see the Embedded Trace Macrocell Specification, ARM Ltd. -IHI 0014H.

Three-state Sequencer

The sequencer has three possible next states (one dedicated to itself and two others) and can change on every clock cycle. The state transition is controlled with internal events. If the user needs multiple-stage trigger schemes, the trigger event is based on a sequencer state.

Address Comparator

In single mode, address comparators compare either the instruction address or the data address against the user-programmed address.

In range mode, the address comparators are arranged in pairs to form a virtual address range resource.

Details of the address comparator programming are:

- The first comparator is programmed with the range start address.
- The second comparator is programmed with the range end address.
- The resource matches if the address is within the following range:
 - (address \geq range start address) AND (address $<$ range end address)
- Unpredictable behavior occurs if the two address comparators are not configured in the same way.

Data Comparator

Each full address comparator is associated with a specific data comparator. A data comparator is used to observe the data bus only when load and store operations occur.

A data comparator has both a value register and a mask register, therefore it is possible to compare only certain bits of a preprogrammed value against the data bus.

Memory Decoder Inputs

The eight memory map decoder inputs are connected to custom address decoders. The address decoders divide the memory into regions of on-chip SRAM, on-chip ROM, and peripherals. The address decoders also optimize the ETM9 trace trigger.

Table 12-2. ETM Memory Map Inputs Layout

Description	Region	Access type	start_address	end_address
SRAM	Internal	Data	0x00000000	0x000FFFFFF
SRAM	Internal	Fetch	0x00000000	0x000FFFFFF
ROM	Internal	Data	0x00100000	0x001FFFFFF
ROM	Internal	Fetch	0x00100000	0x001FFFFFF
NCS0-NCS7	External	Data	0x10000000	0x8FFFFFFF
NCS0-NCS7	External	Fetch	0x10000000	0x8FFFFFFF
User Peripheral	Internal	Data	0xF0000000	0xFFFFEFFF
System Peripheral	Internal	Data	0xFFFFF000	0xFFFFFFF

FIFO

An 18-byte FIFO is used to store data tracing. The FIFO is used to separate the pipeline status from the trace packet. So, the FIFO can be used to buffer trace packets.

A FIFO overflow is detected by the embedded trace macrocell when the FIFO is full or when the FIFO has less bytes than the user-programmed number.

For further details, see the ETM9 (Rev2a) Technical Reference Manual, ARM Ltd. DDI 0157E.

Half-rate Clocking Mode

The ETM9 is implemented in half-rate mode that allows both rising and falling edge data tracing of the trace clock.

The half-rate mode is implemented to maintain the signal clock integrity of high speed systems (up to 100 Mhz).

Figure 12-5. Half-rate Clocking Mode

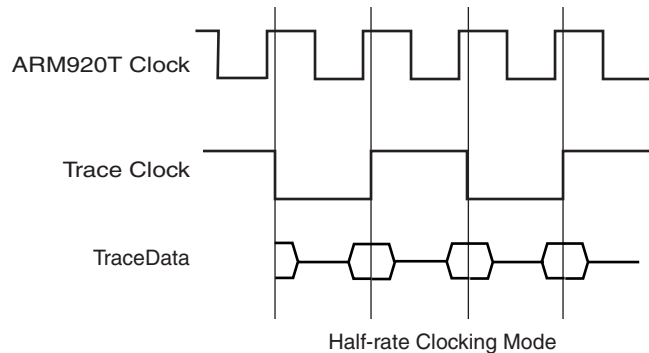

Care must be taken on the choice of the trace capture system as it needs to support half-rate clock functionality.

12.6.4.3 Application Board Restriction

The TCLK signal needs to be set with care, some timing parameters are required.

Refer to AT91RM9200 “JTAG/ICE Timings” on page 657 and “ETM Timings” on page 660.

The specified target system connector is the AMP Micror connector.

The connector must be oriented on the application board as described below in Figure 12-6. The view of the PCB is shown from above with the trace connector mounted near the edge of the board. This allows the Trace Port Analyzer to minimize the physical intrusiveness of the inter-connected target.

Figure 12-6. AMP Micror Connector Orientation

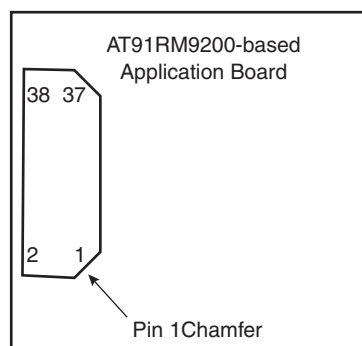

12.6.5 IEEE 1149.1 JTAG Boundary Scan

IEEE 1149.1 JTAG Boundary Scan allows pin-level access independent of the device packaging technology.

IEEE 1149.1 JTAG Boundary Scan is enabled when JTAGSEL is high. The SAMPLE, EXTEST and BYPASS functions are implemented. In ICE debug mode, the ARM processor responds with a non-JTAG chip ID that identifies the processor to the ICE system. This is not IEEE 1149.1 JTAG-compliant.

It is not possible to switch directly between JTAG and ICE operations. A chip reset must be performed (NRST and NTRST) after JTAGSEL is changed.

Two Boundary Scan Descriptor Language (BSDL) files are provided to set up testing. Each BSDL file is dedicated to a specific packaging.

12.6.5.1 JTAG Boundary Scan Register

The Boundary Scan Register (BSR) contains 449 bits which correspond to active pins and associated control signals.

Each AT91RM9200 input pin has a corresponding bit in the Boundary Scan Register for observability.

Each AT91RM9200 output pin has a corresponding 2-bit register in the BSR. The OUTPUT bit contains data which can be forced on the pad. The CTRL bit can put the pad into high impedance.

Each AT91RM9200 input/output pin corresponds to a 3-bit register in the BSR. The OUTPUT bit contains data that can be forced on the pad. The INPUT bit facilitates the observability of data applied to the pad. The CTRL bit selects the direction of the pad.

Table 12-3. JTAG Boundary Scan Register

Bit Number	Pin Name	Pin Type	Associated BSR Cells
449	A19	Output	OUTPUT
448	A[19:16]/BA0/BA1	Output	CTRL
447	A20	Output	OUTPUT
446	A[22:20]/NWE/NWR0	Output	CTRL
445	A21	Output	OUTPUT
444	A22	Output	OUTPUT
443	PC7/A23	I/O	INPUT
442			OUTPUT
441			CTRL
440	PC8/A24	I/O	INPUT
439			OUTPUT
438			CTRL
437	PC9/A25/CFRNW	I/O	INPUT
436			OUTPUT
435			CTRL
434	NCS0/BFCS	Output	OUTPUT
433	NCS[1:0]/NOE/NRD/NUB/ NWR1/NBS1/BFCS/SDCS	Output	CTRL
432	NCS1/SDCS	Output	OUTPUT
431	NCS2	Output	OUTPUT
430	NCS[2:3]/NBS3	Output	CTRL
429	NCS3	Output	OUTPUT
428	NOE/NRD	Output	OUTPUT
427	NWE/NWR0	Output	INPUT
426			OUTPUT
425	NUB/NWR1/NBS1	Output	INPUT
424			OUTPUT
423	NBS3	Output	OUTPUT
422	SDCKE	Output	OUTPUT
421	SDCKE/RAS/CAS/WE/SDA10	Output	CTRL
420	RAS	Output	OUTPUT
419	CAS	Output	OUTPUT
418	WE	Output	OUTPUT

Table 12-3. JTAG Boundary Scan Register (Continued)

Bit Number	Pin Name	Pin Type	Associated BSR Cells
417	D0	I/O	INPUT
416			OUTPUT
415	D[3:0]	I/O	CTRL
414	D1	I/O	INPUT
413			OUTPUT
412	D2	I/O	INPUT
411			OUTPUT
410	D3	I/O	INPUT
409			OUTPUT
408	D4	I/O	INPUT
407			OUTPUT
406	D[7:4]	I/O	CTRL
405	D5	I/O	INPUT
404			OUTPUT
403	D6	I/O	INPUT
402			OUTPUT
401	D7	I/O	INPUT
400			OUTPUT
399	D8	I/O	INPUT
398			OUTPUT
397	D[11:8]	I/O	CTRL
396	D9	I/O	INPUT
395			OUTPUT
394	D10	I/O	INPUT
393			OUTPUT
392	D11	I/O	INPUT
391			OUTPUT
390	D12	I/O	INPUT
389			OUTPUT
388	D[15:12]	I/O	CTRL
387	D13	I/O	INPUT
386			OUTPUT
385	D14	I/O	INPUT
384			OUTPUT

Table 12-3. JTAG Boundary Scan Register (Continued)

Bit Number	Pin Name	Pin Type	Associated BSR Cells
383	D15	I/O	INPUT
382			OUTPUT
381	PC16/D16	I/O	INPUT
380			OUTPUT
379			CTRL
378	PC17/D17	I/O	INPUT
377			OUTPUT
376			CTRL
375	PC18/D18	I/O	INPUT
374			OUTPUT
373			CTRL
372	PC19/D19	I/O	INPUT
371			OUTPUT
370			CTRL
369	PC20/D20	I/O	INPUT
368			OUTPUT
367			CTRL
366	PC21/D21	I/O	INPUT
365			OUTPUT
364			CTRL
363	PC22/D22	I/O	INPUT
362			OUTPUT
361			CTRL
360	PC23/D23	I/O	INPUT
359			OUTPUT
358			CTRL
357	PC24/D24	I/O	INPUT
356			OUTPUT
355			CTRL
354	PC25/D25	I/O	INPUT
353			OUTPUT
352			CTRL
351	PC26/D26	I/O	INPUT
350			OUTPUT
349			CTRL

Table 12-3. JTAG Boundary Scan Register (Continued)

Bit Number	Pin Name	Pin Type	Associated BSR Cells
348	PC27/D27	I/O	INPUT
347			OUTPUT
346			CTRL
345	PC28/D28	I/O	INPUT
344			OUTPUT
343			CTRL
342	PC29/D29	I/O	INPUT
341			OUTPUT
340			CTRL
339	PC30/D30	I/O	INPUT
338			OUTPUT
337			CTRL
336	PC31/D31	I/O	INPUT
335			OUTPUT
334			CTRL
333	PC10/NCS4/CFCS	I/O	INPUT
332			OUTPUT
331			CTRL
330	PC11/NCS5/CFCE1	I/O	INPUT
329			OUTPUT
328			CTRL
327	PC12/NCS6/CFCE2	I/O	INPUT
326			OUTPUT
325			CTRL
324	PC13/NCS7	I/O	INPUT
323			OUTPUT
322			CTRL
321	PC14	I/O	INPUT
320			OUTPUT
319			CTRL
318	PC15	I/O	INPUT
317			OUTPUT
316			CTRL

Table 12-3. JTAG Boundary Scan Register (Continued)

Bit Number	Pin Name	Pin Type	Associated BSR Cells
315	PC0/BCFK	I/O	INPUT
314			OUTPUT
313			CTRL
312	PC1/BFRDY/SMOE	I/O	INPUT
311			OUTPUT
310			CTRL
309	PC2/BFAVD	I/O	INPUT
308			OUTPUT
307			CTRL
306	PC3/BFBAA/SMWE	I/O	INPUT
305			OUTPUT
304			CTRL
303	PC4/BFOE	I/O	INPUT
302			OUTPUT
301			CTRL
300	PC5/BFWE	I/O	INPUT
299			OUTPUT
298			CTRL
297	PC6/NWAIT	I/O	INPUT
296			OUTPUT
295			CTRL
294	PA0/MISO/PCK3	I/O	INPUT
293			OUTPUT
292			CTRL
291	PA1/MOSI/PCK0	I/O	INPUT
290			OUTPUT
289			CTRL
288	PA2/SPCK/IRQ4	I/O	INPUT
287			OUTPUT
286			CTRL
285	PA3/NPCS0/IRQ5	I/O	INPUT
284			OUTPUT
283			CTRL

Table 12-3. JTAG Boundary Scan Register (Continued)

Bit Number	Pin Name	Pin Type	Associated BSR Cells
282	PA4/NPCS1/PCK1	I/O	INPUT
281			OUTPUT
280			CTRL
279	PA5/NPCS2/TXD3	I/O	INPUT
278			OUTPUT
277			CTRL
276	PD0/ETX0	I/O	INPUT
275			OUTPUT
274			CTRL
273	PD1/ETX1	I/O	INPUT
272			OUTPUT
271			CTRL
270	PD2/ETX2	I/O	INPUT
269			OUTPUT
268			CTRL
267	PD3/ETX3	I/O	INPUT
266			OUTPUT
265			CTRL
264	PD4/ETXEN	I/O	INPUT
263			OUTPUT
262			CTRL
261	PD5/ETXER	I/O	INPUT
260			OUTPUT
259			CTRL
258	PD6/DTXD	I/O	INPUT
257			OUTPUT
256			CTRL
255	PA6/NPCS3/RXD3	I/O	INPUT
254			OUTPUT
253			CTRL
252	PA7/ETXCK/EREFCK/PCK2	I/O	INPUT
251			OUTPUT
250			CTRL

Table 12-3. JTAG Boundary Scan Register (Continued)

Bit Number	Pin Name	Pin Type	Associated BSR Cells
249	PA8/ETXEN/MCCDB	I/O	INPUT
248			OUTPUT
247			CTRL
246	PA9/ETX0/MCDB0	I/O	INPUT
245			OUTPUT
244			CTRL
243	PA10/ETX1/MCDB1	I/O	INPUT
242			OUTPUT
241			CTRL
240	PA11/ECRS/ECRSDV/MCDB2	I/O	INPUT
239			OUTPUT
238			CTRL
237	PA12/ERX0/MCDB3	I/O	INPUT
236			OUTPUT
235			CTRL
234	PA13/ERX1/TCLK0	I/O	INPUT
233			OUTPUT
232			CTRL
231	PA14/ERXER/TCLK1	I/O	INPUT
230			OUTPUT
229			CTRL
228	PA15/EMDC/TCLK2	I/O	INPUT
227			OUTPUT
226			CTRL
225	PA16/EMDIO/IRQ6	I/O	INPUT
224			OUTPUT
223			CTRL
222	PA17/TXD0/TIOA0	I/O	INPUT
221			OUTPUT
220			CTRL
219	PA18/RXD0/TIOB0	I/O	INPUT
218			OUTPUT
217			CTRL

Table 12-3. JTAG Boundary Scan Register (Continued)

Bit Number	Pin Name	Pin Type	Associated BSR Cells
216	PA19/SCK0/TIOA1	I/O	INPUT
215			OUTPUT
214			CTRL
213	PA20/CTS0/TIOB1	I/O	INPUT
212			OUTPUT
211			CTRL
210	PA21/RTS0/TIOA2	I/O	INPUT
209			OUTPUT
208			CTRL
207	PA22/RXD2/TIOB2	I/O	INPUT
206			OUTPUT
205			CTRL
204	PA23/TXD2/IRQ3	I/O	INPUT
203			OUTPUT
202			CTRL
201	PA24/SCK2/PCK1	I/O	INPUT
200			OUTPUT
199			CTRL
198	PA25/TWD/IRQ2	I/O	INPUT
197			OUTPUT
196			CTRL
195	PA26/TWCK/IRQ1	I/O	INPUT
194			OUTPUT
193			CTRL
192	PA27/MCCK/TCLK3	I/O	INPUT
191			OUTPUT
190			CTRL
189	PA28/MCCDA/TCLK4	I/O	INPUT
188			OUTPUT
187			CTRL
186	PA29/MCDA0/TCLK5	I/O	INPUT
185			OUTPUT
184			CTRL

Table 12-3. JTAG Boundary Scan Register (Continued)

Bit Number	Pin Name	Pin Type	Associated BSR Cells
183	PA30/DRXD/CTS2	I/O	INPUT
182			OUTPUT
181			CTRL
180	PA31/DTXD/RTS2	I/O	INPUT
179			OUTPUT
178			CTRL
177	PB0/TF0/RTS3	I/O	INPUT
176			OUTPUT
175			CTRL
174	PB1/TK0/CTS3	I/O	INPUT
173			OUTPUT
172			CTRL
171	PB2/TD0/SCK3	I/O	INPUT
170			OUTPUT
169			CTRL
168	PB3/RD0/MCDA1	I/O	INPUT
167			OUTPUT
166			CTRL
165	PB4/RK0/MCDA2	I/O	INPUT
164			OUTPUT
163			CTRL
162	PB5/RF0/MCDA3	I/O	INPUT
161			OUTPUT
160			CTRL
159	PB6/TF1/TIOA3	I/O	INPUT
158			OUTPUT
157			CTRL
156	PB7/TK1/TIOB3	I/O	INPUT
155			OUTPUT
154			CTRL
153	PB8/TD1/TIOA4	I/O	INPUT
152			OUTPUT
151			CTRL

Table 12-3. JTAG Boundary Scan Register (Continued)

Bit Number	Pin Name	Pin Type	Associated BSR Cells
150	PB9/RD1/TIOB4	I/O	INPUT
149			OUTPUT
148			CTRL
147	PB10/RK1/TIOA5	I/O	INPUT
146			OUTPUT
145			CTRL
144	PB11/RF1/TIOB5	I/O	INPUT
143			OUTPUT
142			CTRL
141	PB12/TF2/ETX2	I/O	INPUT
140			OUTPUT
139			CTRL
138	PB13/TK2/ETX3	I/O	INPUT
137			OUTPUT
136			CTRL
135	PB14/TD2/ETXER	I/O	INPUT
134			OUTPUT
133			CTRL
132	PB15/RD2/ERX2	I/O	INPUT
131			OUTPUT
130			CTRL
129	PB16/RK2/ERX3	I/O	INPUT
128			OUTPUT
127			CTRL
126	PD7/PCK0/TSYNC	I/O	INPUT
125			OUTPUT
124			CTRL
123	PD8/PCK1/TCLK	I/O	INPUT
122			OUTPUT
121			CTRL
120	PD9/PCK2/TPS0	I/O	INPUT
119			OUTPUT
118			CTRL

Table 12-3. JTAG Boundary Scan Register (Continued)

Bit Number	Pin Name	Pin Type	Associated BSR Cells
117	PD10/PCK3/TPS1	I/O	INPUT
116			OUTPUT
115			CTRL
114	PD11/TPS2	I/O	INPUT
113			OUTPUT
112			CTRL
111	PD12/TPK0	I/O	INPUT
110			OUTPUT
109			CTRL
108	PB17/RF2/ERXDV	I/O	INPUT
107			OUTPUT
106			CTRL
105	PB18/RI1/ECOL	I/O	INPUT
104			OUTPUT
103			CTRL
102	PB19/DTR1/ERXCK	I/O	INPUT
101			OUTPUT
100			CTRL
99	PB20/TXD1	I/O	INPUT
98			OUTPUT
97			CTRL
96	PB21/RXD1	I/O	INPUT
95			OUTPUT
94			CTRL
93	PB22/SCK1	I/O	INPUT
92			OUTPUT
91			CTRL
90	PD13/TPK1	I/O	INPUT
89			OUTPUT
88			CTRL
87	PD14/TPK2	I/O	INPUT
86			OUTPUT
85			CTRL

Table 12-3. JTAG Boundary Scan Register (Continued)

Bit Number	Pin Name	Pin Type	Associated BSR Cells
84	PD15/TD0/TPK3	I/O	INPUT
83			OUTPUT
82			CTRL
81	PB23/DCD1	I/O	INPUT
80			OUTPUT
79			CTRL
78	PB24/CTS1	I/O	INPUT
77			OUTPUT
76			CTRL
75	PB25/DSR1/EF100	I/O	INPUT
74			OUTPUT
73			CTRL
72	PB26/RTS1	I/O	INPUT
71			OUTPUT
70			CTRL
69	PB27/PCK0	I/O	INPUT
68			OUTPUT
67			CTRL
66	PD16/TD1/TPK4	I/O	INPUT
65			OUTPUT
64			CTRL
63	PD17/TD2/TPK5	I/O	INPUT
62			OUTPUT
61			CTRL
60	PD18/NPCS1/TPK6	I/O	INPUT
59			OUTPUT
58			CTRL
57	PD19/NPCS2/TPK7	I/O	INPUT
56			OUTPUT
55			CTRL
54	PD20/NPCS3/TPK8	I/O	INPUT
53			OUTPUT
52			CTRL

Table 12-3. JTAG Boundary Scan Register (Continued)

Bit Number	Pin Name	Pin Type	Associated BSR Cells
51	PD21/RTS0/TPK9	I/O	INPUT
50			OUTPUT
49			CTRL
48	PD22/RTS1/TPK10	I/O	INPUT
47			OUTPUT
46			CTRL
45	PD23/RTS2/TPK11	I/O	INPUT
44			OUTPUT
43			CTRL
42	PD24/RTS3/TPK12	I/O	INPUT
41			OUTPUT
40			CTRL
39	PD25/DTR1/TPK13	I/O	INPUT
38			OUTPUT
37			CTRL
36	PD26/TPK14	I/O	INPUT
35			OUTPUT
34			CTRL
33	PD27/TPK15	I/O	INPUT
32			OUTPUT
31			CTRL
30	PB28/FIQ	I/O	INPUT
29			OUTPUT
28			CTRL
27	PB29/IRQ0	I/O	INPUT
26			OUTPUT
25			CTRL
24	A0/NLB/NBS0	Output	OUTPUT
23	A[3:0]/NLB/NWR2/NBS0 /NBS2	Output	CTRL
22	A1/NWR2/NBS2	Output	OUTPUT
21	A2	Output	OUTPUT
20	A3	Output	OUTPUT
19	A4	Output	OUTPUT
18	A[7:4]	Output	CTRL
17	A5	Output	OUTPUT

Table 12-3. JTAG Boundary Scan Register (Continued)

Bit Number	Pin Name	Pin Type	Associated BSR Cells
16	A6	Output	OUTPUT
15	A7	Output	OUTPUT
14	A8	Output	OUTPUT
13	A[11:8]	Output	CTRL
12	A9	Output	OUTPUT
11	A10	Output	OUTPUT
10	SDA10	Output	OUTPUT
9	A11	Output	OUTPUT
8	A12	Output	OUTPUT
7	A[15:12]	Output	CTRL
6	A13	Output	OUTPUT
5	A14	Output	OUTPUT
4	A15	Output	OUTPUT
3	A16/BA0	Output	OUTPUT
2	A17/BA1	Output	OUTPUT
1	A18	Output	OUTPUT

12.6.6 AT91RM9200 ID Code Register

Access: Read-only

31	30	29	28	27	26	25	24
VERSION				PART NUMBER			
23	22	21	20	19	18	17	16
PART NUMBER							
15	14	13	12	11	10	9	8
PART NUMBER				MANUFACTURER IDENTITY			
7	6	5	4	3	2	1	0
MANUFACTURER IDENTITY							1

- **VERSION[31:28]: Product Version Number**

Set to 0x0 = JTAGSEL is low.

Set to 0x1 = JTAGSEL is high.

- **PART NUMBER[27:14]: Product Part Number**

Set to 0x5b02.

- **MANUFACTURER IDENTITY[11:1]**

Set to 0x01f.

- **Bit [0]: Required by IEEE Std. 1149.1**

Set to 1.

The AT91RM9200 ID Code value is 0x15b0203f (JTAGSEL is High).

The AT91RM9200 ID Code value is 0x05b0203f (JTAGSEL is Low).

13. Boot Program

13.1 Overview

The Boot Program is capable of downloading an application in an AT91RM9200-based system. It integrates a Bootloader and a boot Uploader to assure correct information download.

The Bootloader is activated first. It looks for a sequence of eight valid ARM exception vectors in a DataFlash connected to the SPI, an EEPROM connected to the Two-wire Interface (TWI) or an 8-bit memory device connected to the external bus interface (EBI). All these vectors must be Bbranch or LDR load register instructions except for the sixth instruction. This vector is used to store information, such as the size of the image to download and the type of DataFlash device.

If a valid sequence is found, code is downloaded into the internal SRAM. This is followed by a remap and a jump to the first address of the SRAM.

If no valid ARM vector sequence is found, the boot Uploader is started. It initializes the Debug Unit serial port (DBGU) and the USB Device Port. It then waits for any transaction and downloads a piece of code into the internal SRAM via a Device Firmware Upgrade (DFU) protocol for USB and XMODEM protocol for the DBGU. After the end of the download, it branches to the application entry point at the first address of the SRAM.

The main features of the Boot Program are:

- Default Boot Program stored in ROM-based products
- Downloads and runs an application from external storage media into internal SRAM
- Downloaded code size depends on embedded SRAM size
- Automatic detection of valid application
- Bootloader supporting a wide range of non-volatile memories
 - SPI DataFlash connected on SPI NPCS0
 - Two-wire EEPROM
 - 8-bit parallel memories on NCS0
- Boot Uploader in case no valid program is detected in external NVM and supporting several communication media
- Serial communication on a DBGU (XModem protocol)
- USB Device Port (DFU Protocol)

13.2 Flow Diagram

The Boot Program implements the algorithm presented in [Figure 13-1](#).

Figure 13-1. Boot Program Algorithm Flow Diagram

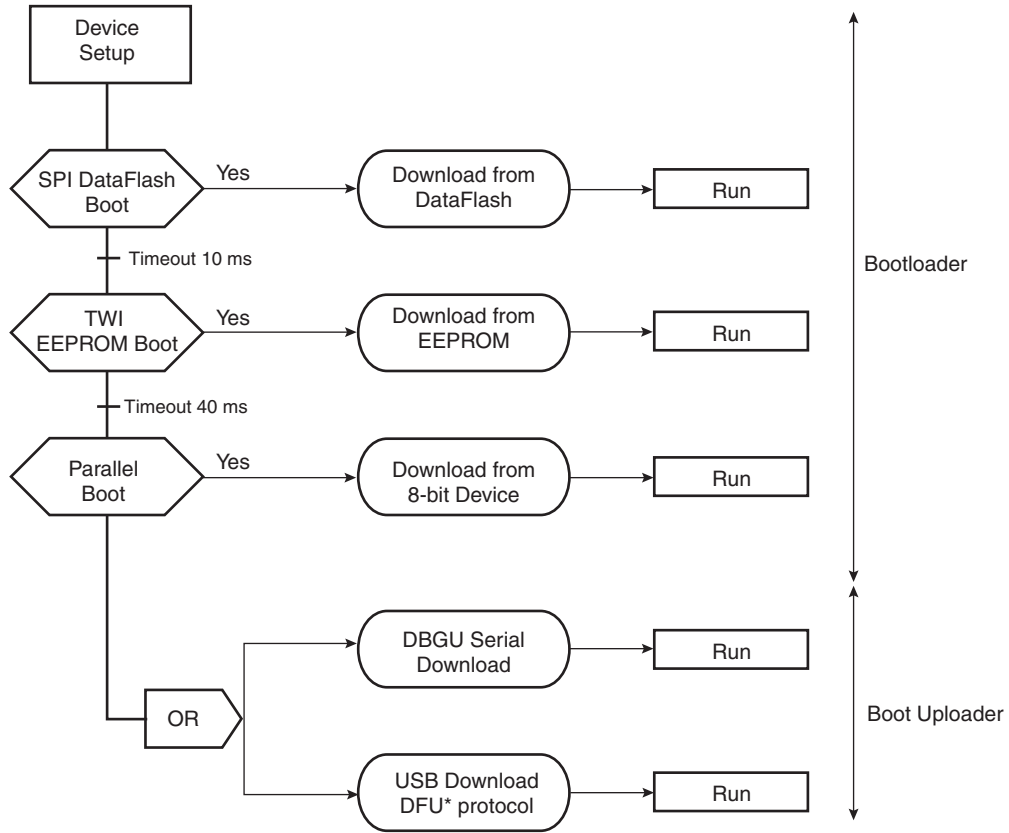

*DFU = Device Firmware Upgrade

13.3 Bootloader

The Boot Program is started from address 0x0000_0000 (ARM reset vector) when the on-chip boot mode is selected (BMS high during the reset, only on devices with EBI integrated). The first operation is the search for a valid program in the off-chip non-volatile memories. If a valid application is found, this application is loaded into internal SRAM and executed by branching at address 0x0000_0000 after remap. This application may be the application code or a second-level Bootloader.

To optimize the downloaded application code size, the Boot Program embeds several functions that can be reused by the application. The Boot Program is linked at address 0x0010_0000 but the internal ROM is mapped at both 0x0000_0000 and 0x0010_0000 after reset. All the call to functions is PC relative and does not use absolute addresses. The ARM vectors are present at both addresses, 0x0000_0000 and 0x0010_0000.

To access the functions in ROM, a structure containing chip descriptor and function entry points is defined at a fixed address in ROM.

If no valid application is detected, the debug serial port or the USB device port must be connected to allow the upload. A specific application provided by Atmel (DFU uploader) loads the application into internal SRAM through the USB. To load the application through the debug serial port, a terminal application (HyperTerminal) running the Xmodem protocol is required.

Figure 13-2. Remap Action after Download Completion

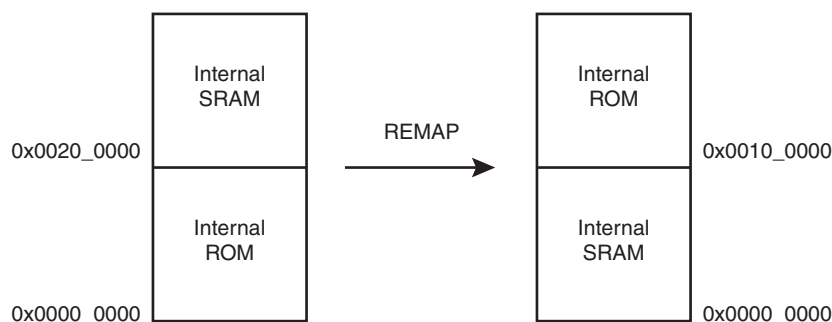

After reset, the code in internal ROM is mapped at both addresses 0x0000_0000 and 0x0010_0000:

```

100000 ea00000b B      0x2c00ea00000bB0x2c
100004 e59ff014 LDR   PC, [PC, 20] 04e59ff014LDRPC, [PC, 20]
100008 e59ff014 LDR   PC, [PC, 20] 08e59ff014LDRPC, [PC, 20]
10000c e59ff014 LDR   PC, [PC, 20] 0ce59ff014LDRPC, [PC, 20]
100010 e59ff014 LDR   PC, [PC, 20] 10e59ff014LDRPC, [PC, 20]
100014 00001234 LDR   PC, [PC, 20] 1400001234LDRPC, [PC, 20]
100018 e51fff20 LDR   PC, [PC, -0xf20] 18e51fff20LDRPC, [PC, -0xf20]
10001c e51fff20 LDR   PC, [PC, -0xf20] 1ce51fff20LDRPC, [PC, -0xf20]
    
```

13.3.1 Valid Image Detection

The Bootloader software looks for a valid application by analyzing the first 32 bytes corresponding to the ARM exception vectors. These bytes must implement ARM instructions for either branch or load PC with PC relative addressing. The sixth vector, at offset 0x14, contains the size of the image to download and the DataFlash parameters.

The user must replace this vector with his own vector.

Figure 13-3. LDR Opcode

31	28	27	24	23	20	19	16	15	12	11	0
1	1	1	0	0	1	I	P	U	0	W	1
				Rn				Rd			

Figure 13-4. B Opcode

31	28	27	24	23	0
1	1	1	0	1	0
Offset (24 bits)					

Unconditional instruction: 0xE for bits 31 to 28

Load PC with PC relative addressing instruction:

- Rn = Rd = PC = 0xF
- I==1
- P==1
- U offset added (U==1) or subtracted (U==0)
- W==1

13.3.1.1 Example

An example of valid vectors:

00	ea00000b	B	0x2c	
004	e59ff014	LDR	PC, [PC, 20]	
08	e59ff014	LDR	PC, [PC, 20]	
0c	e59ff014	LDR	PC, [PC, 20]	
10	e59ff014	LDR	PC, [PC, 20]	
14	00001234			<- Code size = 4660 bytes
18	e51fff20	LDR	PC, [PC, -0xf20]	
1c	e51fff20	LDR	PC, [PC, -0xf20]	

In download mode (DataFlash, EEPROM or 8-bit memory in device with EBI integrated), the size of the image to load into SRAM is contained in the location of the sixth ARM vector. Thus the user must replace this vector by the correct vector for his application.

13.3.2 Structure of ARM Vector 6

The ARM exception vector 6 is used to store information needed by the Boot ROM downloader. This information is described below.

Figure 13-5. Structure of the ARM vector 6

31	17	16	13	12	8	7	0
DataFlash page size		Number of pages		Reserved		Nb of 512 bytes blocks to download	

The first eight bits contain the number of blocks to download. The size of a block is 512 bytes, allowing download of up to 128K bytes.

The bits 13 to 16 determine the DataFlash page number.

$$\text{DataFlash page number} = 2^{(\text{Nb of pages})}$$

The last 15 bits contain the DataFlash page size.

Table 13-1. DataFlash Device

Device	Density	Page Size (bytes)	Number of pages
AT45DB011B	1 Mbit	264	512
AT45DB021B	2 Mbits	264	1024
AT45DB041B	4 Mbits	264	2048
AT45DB081B	8 Mbits	264	4096
AT45DB161B	16 Mbits	528	4096
AT45DB321B	32 Mbits	528	8192
AT45DB642	64 Mbits	1056	8192
AT45DB1282	128 Mbits	1056	16384

13.3.2.1 Example

The following vector contains the information to describe a AT45DB642 DataFlash which contains 11776 bytes to download.

Vector 6 is 0x0841A017 (00001000010000011010000000010111b):

$$\text{Size to download: } 0x17 * 512 \text{ bytes} = 11776 \text{ bytes}$$

$$\text{Number pages (1101b): } 13 \implies \text{Number of DataFlash pages} = 2^{13} = 8192$$

$$\text{DataFlash page size(000010000100000b)} = 1056$$

For download in the EEPROM or 8-bit external memory, only the size to be downloaded is decoded.

13.3.3 Bootloader Sequence

The Boot Program performs device initialization followed by the download procedure. If unsuccessful, the upload is done via the USB or debug serial port.

13.3.3.1 Device Initialization

Initialization follows the steps described below:

1. PLL setup
 - PLLB is initialized to generate a 48 MHz clock necessary to use the USB Device. A register located in the Power Management Controller (PMC) determines the frequency of the main oscillator and thus the correct factor for the PLLB.

[Table 13-2](#) defines the crystals supported by the Boot Program.

Table 13-2. Crystals Supported by Software Auto-detection (MHz)

3.0	3.2768	3.6864	3.84	4.0
4.433619	4.9152	5.0	5.24288	6.0
6.144	6.4	6.5536	7.159090	7.3728
7.864320	8.0	9.8304	10.0	11.05920
12.0	12.288	13.56	14.31818	14.7456
16.0	17.734470	18.432	20.0	

2. Stacks setup for each ARM mode
3. Main oscillator frequency detection
4. Interrupt controller setup
5. C variables initialization
6. Branch main function

13.3.3.2 Download Procedure

The download procedure checks for a valid boot on several devices. The first device checked is a serial DataFlash connected to the NPCS0 of the SPI, followed by the serial EEPROM connected to the TWI and by an 8-bit parallel memory connected on NCS0 of the External Bus Interface.

13.3.3.3 Serial DataFlash Download

The Boot Program supports all Atmel DataFlash devices. [Table 13-1](#) summarizes the parameters to include in the ARM vector 6 for all devices.

The DataFlash has a Status Register that determines all the parameters required to access the device.

Thus, to be compatible with the future design of the DataFlash, parameters are coded in the ARM vector 6.

Figure 13-6. Serial DataFlash Download

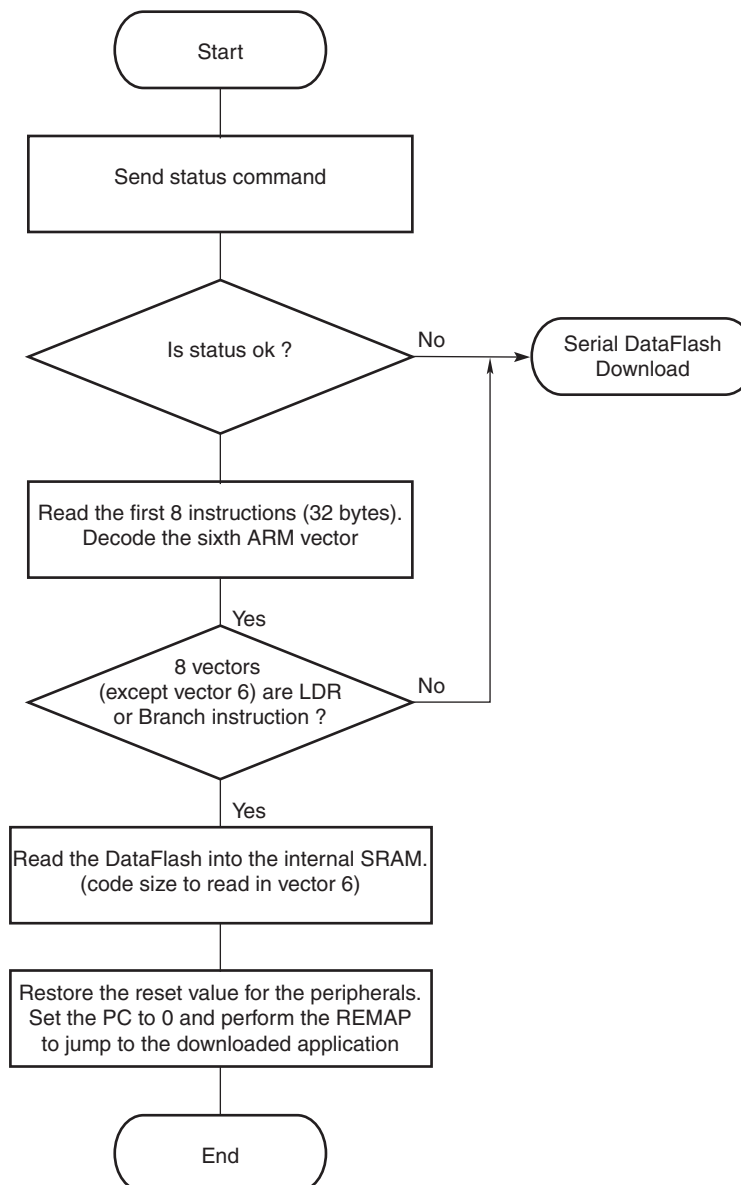

13.3.3.4 Serial Two-wire EEPROM Download

Generally, serial EEPROMs have no identification code. The bootloader checks for an acknowledgment on the first read. The device address on the two-wire bus must be 0x0. The bootloader supports the devices listed in [Table 13-3](#).

Table 13-3. Supported EEPROM Devices

Device	Size	Organization
AT24C16A	16 Kbits	16 bytes page write
AT24C164	16 Kbits	16 bytes page write
AT24C32	32 Kbits	32 bytes page write
AT24C64	64 Kbits	32 bytes page write
AT24C128	128 Kbits	64 bytes page write
AT24C256	256 Kbits	64 bytes page write
AT24C512	528 Kbits	128 bytes page write

Figure 13-7. Serial Two-Wire EEPROM Download

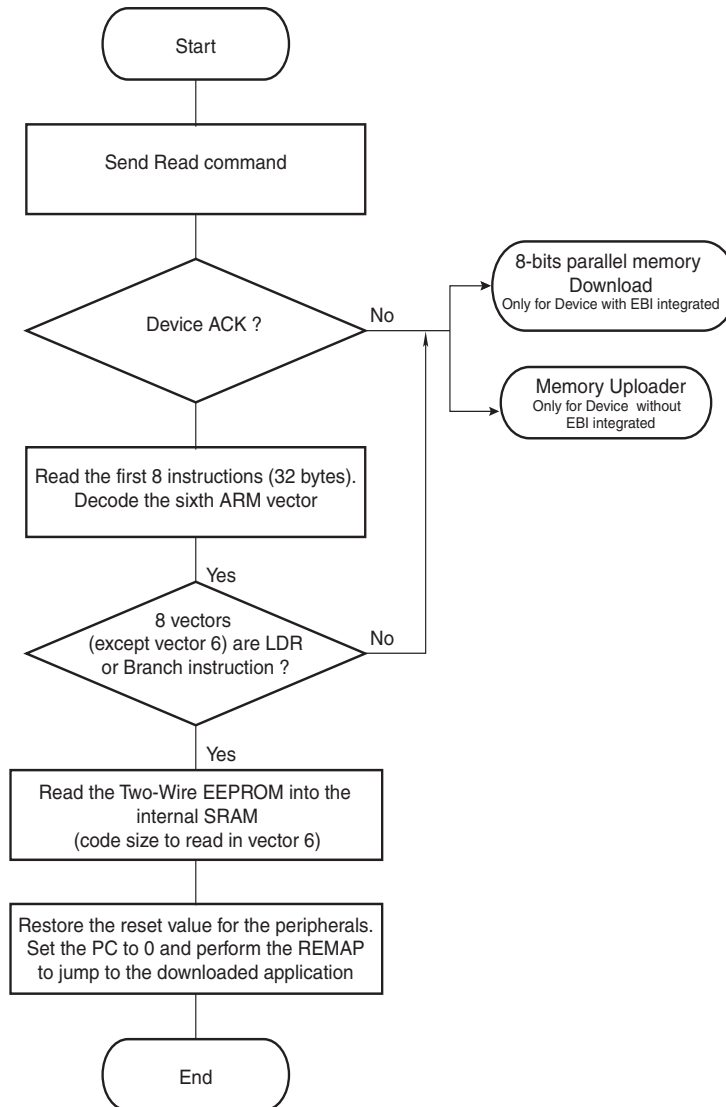

13.3.3.5 8-bit Parallel Flash Download (Applicable to Devices with EBI)

Eight-bit parallel Flash download is supported if the product integrates an External Bus Interface (EBI).

All 8-bit memory devices supported by the EBI when NCS0 is configured in 8-bit data bus width are supported by the bootloader.

Figure 13-8. 8-bit Parallel Flash Download

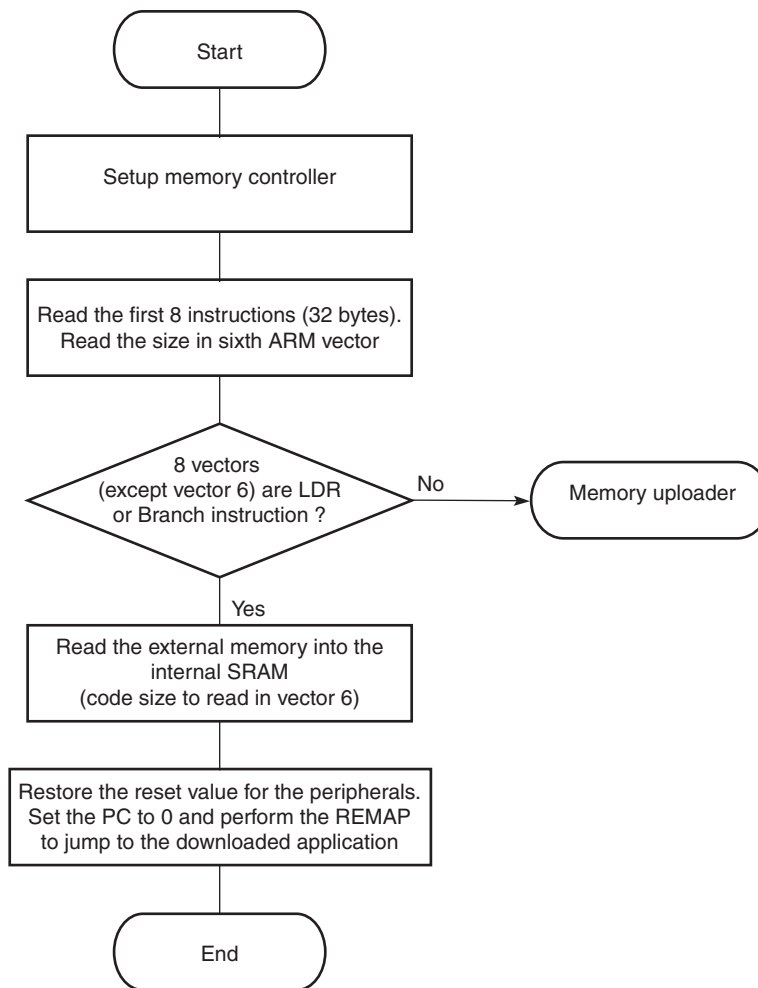

13.4 Boot Uploader

If no valid boot device has been found during the Bootloader sequence, initialization of serial communication devices (DBGU and USB device ports) is performed.

- Initialization of the DBGU serial port (115200 bauds, 8, N, 1) and Xmodem protocol start
- Initialization of the USB Device Port and DFU protocol start
- Download of the application

The boot Uploader performs the DFU and Xmodem protocols to upload the application into internal SRAM at address 0x0020_0000.

The Boot Program uses a piece of internal SRAM for variables and stacks. To prevent any upload error, the size of the application to upload must be less than the SRAM size minus 3K bytes.

After the download, the peripheral registers are reset, the interrupts are disabled and the remap is performed. After the remap, the internal SRAM is at address 0x0000_0000 and the internal ROM at address 0x0010_0000. The instruction setting the PC to 0 is the one just after the remap command. This instruction is fetched in the pipe before doing the remap and executed just after. This fetch cycle executes the downloaded image.

13.4.1 External Communication Channels

13.4.1.1 *DBGU Serial Port*

The upload is performed through the DBGU serial port initialized to 115200 Baud, 8, n, 1.

The DBGU sends the character 'C' (0x43) to start an Xmodem protocol. Any terminal performing this protocol can be used to send the application file to the target. The size of the binary file to send depends on the SRAM size embedded in the product (Refer to the microcontroller datasheet to determine SRAM size embedded in the microcontroller). In all cases, the size of the binary file must be lower than SRAM size because the Xmodem protocol requires some SRAM memory to work.

13.4.1.2 *Xmodem Protocol*

The Xmodem protocol supported is the 128-byte length block. This protocol uses a two character CRC-16 to guarantee detection of a maximum bit error.

Xmodem protocol with CRC is accurate provided both sender and receiver report successful transmission. Each block of the transfer looks like:

<SOH><blk #><255-blk #><--128 data bytes--><checksum> in which:

- <SOH> = 01 hex
- <blk #> = binary number, starts at 01, increments by 1, and wraps 0FFH to 00H (not to 01)
- <255-blk #> = 1's complement of the blk#.
- <checksum> = 2 bytes CRC16

Figure 13-9 shows a transmission using this protocol.

Figure 13-9. Xmodem Transfer Example

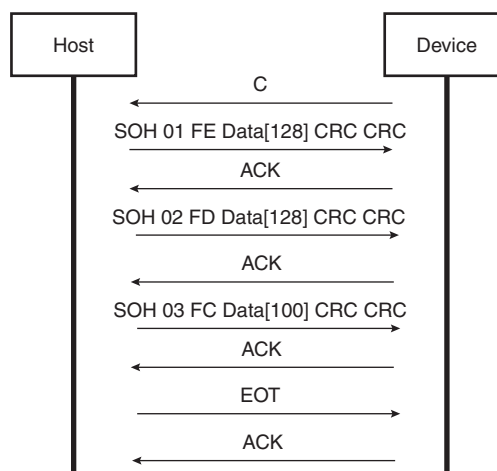

13.4.1.3 USB Device Port

A 48 MHz USB clock is necessary to use USB Device port. It has been programmed earlier in the device initialization with PLLB configuration.

13.4.1.4 DFU Protocol

The DFU allows upgrade of the firmware of USB devices. The DFU algorithm is a part of the USB specification. For more details, refer to “USB Device Firmware Upgrade Specification, Rev. 1.0”.

There are four distinct steps when carrying out a firmware upgrade:

1. Enumeration: The device informs the host of its capabilities.
2. Reconfiguration: The host and the device agree to initiate a firmware upgrade.
3. Transfer: The host transfers the firmware image to the device. Status requests are employed to maintain synchronization between the host and the device.
4. Manifestation: Once the device reports to the host that it has completed the reprogramming operations, the host issues a reset and the device executes the upgraded firmware.

Figure 13-10. DFU Protocol

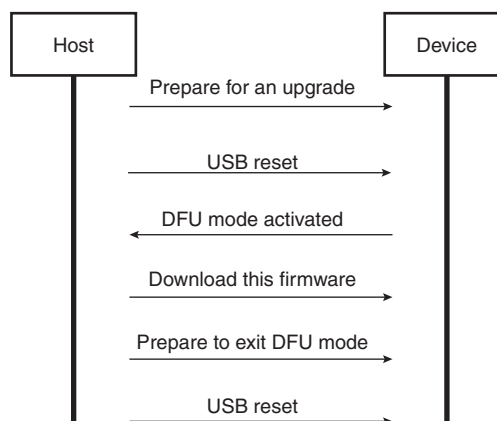

13.5 Hardware and Software Constraints

The software limitations of the Boot Program are:

- The downloaded code size is less than the SRAM size -4K embedded in the product.
- The device address of the EEPROM must be 0 on the TWI bus.
- The code is always downloaded from the device address 0x0000_0000 (DataFlash, EEPROM) to the address 0x0000_0000 of the internal SRAM (after remap).
- The downloaded code must be position-independent or linked at address 0x0000_0000.

The hardware limitations of the Boot Program are:

- The DataFlash must be connected to NPCS0 of the SPI.
- The 8-bit parallel Flash must be connected to NCS0 of the EBI.
- The Boot Program initializes the DBGU pins multiplexed on the PIO common to both the 208-lead PQFP and 256-ball BGA packages, in this case meaning PIOA.
- Using an external clock source on the XIN pin is not possible as the main oscillator is enabled by the Boot ROM.

The SPI and TWI drivers use several PIOs in alternate functions to communicate with devices. Care must be taken when these PIOs are used by the application. The devices connected could be unintentionally driven at boot time, and electrical conflicts between SPI or TWI output pins and the connected devices may appear.

To assure correct functionality, it is recommended to plug in critical devices to other pins or to boot on an external 16-bit parallel memory by setting bit BMS.

Table 13-4 contains a list of pins that are driven during the Boot Program execution. These pins are driven during the boot sequence for a period of about 6 ms if no correct boot program is found. The download through the TWI takes about 5 sec for 64K bytes due to the TWI bit rate (100 Kbits/s).

For the DataFlash driven by SPCK signal at 12 MHz, the time to download 64K bytes is reduced to 66 ms.

Before performing the jump to the application in internal SRAM, all the PIOs and peripherals used in the Boot Program are set to their reset state.

Table 13-4. Pins Driven during Boot Program Execution

Pin Used	SPI (DataFlash)	TWI (EEPROM)
MOSI ⁽¹⁾	O	X
SPCK ⁽¹⁾	O	X
NPCS0 ⁽¹⁾	O	X
TWD ⁽¹⁾	X	I/O
TWCK ⁽¹⁾	X	O

Note: 1. See Section 10.3 “Peripheral Multiplexing on PIO Lines” on page 22.

14. Embedded Software Services

14.1 Overview

An embedded software service is an independent software object that drives device resources for frequently implemented tasks. The object-oriented approach of the software provides an easy way to access services to build applications.

An AT91 service has several purposes:

- It gives software examples dedicated to the AT91 devices.
- It can be used on several AT91 device families.
- It offers an interface to the software stored in the ROM.

The main features of the software services are:

- Compliant with ATPCS
- Compliant with ANSI/ISO Standard C
- Compiled in ARM/Thumb Interworking
- ROM Entry Service
- Tempo, Xmodem and DataFlash services
- CRC and Sine tables

14.2 Service Definition

14.2.1 Service Structure

14.2.1.1 *Structure Definition*

A service structure is defined in C header files.

This structure is composed of data members and pointers to functions (methods) and is similar to a class definition. There is no protection of data access or methods access. However, some functions can be used by the customer application or other services and so be considered as public methods. Similarly, other functions are not invoked by them. They can be considered as private methods. This is also valid for data.

14.2.1.2 *Methods*

In the service structure, pointers to functions are supposed to be initialized by default to the standard functions. Only the default standard functions reside in ROM. Default methods can be overloaded by custom application methods.

Methods do not declare any static variables nor invoke global variables. All methods are invoked with a pointer to the service structure. A method can access and update service data without restrictions.

Similarly, there is no polling in the methods. In fact, there is a method to start the functionality (a read to give an example), a method to get the status (is the read achieved?), and a callback, initialized by the start method. Thus, using service, the client application carries out a synchronous read by starting the read and polling the status, or an asynchronous read specifying a callback when starting the read operation.

14.2.1.3 Service Entry Point

Each AT91 service, except for the **ROM Entry Service** (see [14.3.2 “ROM Entry Service” on page 99](#)), defines a function named `AT91F_Open_<Service>`. It is the only entry point defined for a service. Even if the functions `AT91F_Open_<Service>` may be compared with object constructors, they do not act as constructors in that they initiate the service structure but they do not allocate it. Thus the customer application must allocate it.

Example

```
// Allocation of the service structure
AT91S_Pipe pipe;
// Opening of the service
AT91PS_Pipe pPipe = AT91F_OpenPipe(&pipe, ...);
```

Method pointers in the service structure are initialized to the default methods defined in the AT91 service. Other fields in the service structure are initialized to default values or with the arguments of the function `AT91F_Open_<Service>`.

In summary, an application must know what the service structure is and where the function `AT91F_Open_<Service>` is.

The default function `AT91F_Open_<Service>` may be redefined by the application or comprised in an application-defined function.

14.2.2 Using a Service

14.2.2.1 Opening a Service

The entry point to a service is established by initializing the service structure. An open function is associated with each service structure, except for the ROM Entry Service (see [14.3.2 “ROM Entry Service” on page 99](#)). Thus, only the functions `AT91F_Open_<service>` are visible from the user side. Access to the service methods is made via function pointers in the service structure.

The function `AT91F_Open_<service>` has at least one argument: a pointer to the service structure that must be allocated elsewhere. It returns a pointer to the base service structure or a pointer to this service structure.

The function `AT91F_Open_<service>` initializes all data members and method pointers. All function pointers in the service structure are set to the service's functions.

The advantage of this method is to offer a single entry point for a service. The methods of a service are initialized by the open function and each member can be overloaded.

14.2.2.2 Overloading a Method

Default methods are defined for all services provided in ROM. These methods may not be adapted to a project requirement. It is possible to overload default methods by methods defined in the project.

A method is a pointer to a function. This pointer is initialized by the function `AT91F_Open_<Service>`. To overload one or several methods in a service, the function pointer must be updated to the new method.

It is possible to overload just one method of a service or all the methods of a service. In this latter case, the functionality of the service is user-defined, but still works on the same data structure.

Note: Calling the default function `AT91F_Open_<Service>` ensures that all methods and data are initialized.

This can be done by writing a new function `My_OpenService()`. This new Open function must call the library-defined function `AT91F_Open_<Service>`, and then update one or several function pointers:

Table 14-1. Overloading a Method with the Overloading of the Open Service Function

Default service behavior in ROM	Overloading AT91F_ChildMethod by My_ChildMethod
<pre> // Defined in embedded_services.h typedef struct _AT91S_Service { char data; char (*MainMethod) (); char (*ChildMethod) (); } AT91S_Service, * AT91PS_Service; // Defined in obj_service.c (in ROM) char AT91F_MainMethod () { } char AT91F_ChildMethod () { } // Init the service with default methods AT91PS_Service AT91F_OpenService(AT91PS_Service pService) { pService->data = 0; pService->MainMethod =AT91F_MainMethod; pService->ChildMethod=AT91F_ChildMethod; return pService; } </pre>	<pre> // My_ChildMethod will replace AT91F_ChildMethod char My_ChildMethod () { } // Overloading Open Service Method AT91PS_Service My_OpenService(AT91PS_Service pService) { AT91F_OpenService(pService); // Overloading ChildMethod default value pService->ChildMethod= My_ChildMethod; return pService; } // Allocation of the service structure AT91S_Service service; // Opening of the service AT91PS_Service pService = My_OpenService(&service); </pre>

This also can be done directly by overloading the method after the use of `AT91F_Open_<Service>` method:

Table 14-2. Overloading a Method without the Overloading of the Open Service Function.

Default service behavior in ROM	Overloading AT91F_ChildMethod by My_ChildMethod
<pre> // Defined in embedded_services.h typedef struct _AT91S_Service { char data; char (*MainMethod) (); char (*ChildMethod) (); } AT91S_Service, * AT91PS_Service; // Defined in obj_service.c (in ROM) char AT91F_MainMethod () { } char AT91F_ChildMethod () { } // Init the service with default methods AT91PS_Service AT91F_OpenService(AT91PS_Service pService) { pService->data = 0; pService->MainMethod =AT91F_MainMethod; pService->ChildMethod=AT91F_ChildMethod; return pService; } </pre>	<pre> // My_ChildMethod will replace AT91F_ChildMethod char My_ChildMethod () { } // Allocation of the service structure AT91S_Service service; // Opening of the service AT91PS_Service pService = AT91F_OpenService(&service); // Overloading ChildMethod default value pService->ChildMethod= My_ChildMethod; </pre>

14.3 Embedded Software Services

14.3.1 Definition

Several AT91 products embed ROM. In most cases, the ROM integrates a bootloader and several services that may speed up the application and reduce the application code size.

When software is fixed in the ROM, the address of each object (function, constant, table, etc.) must be related to a customer application. This is done by providing an address table to the linker. For each version of ROM, a new address table must be provided and all client applications must be recompiled.

The Embedded Software Services offer another solution to access objects stored in ROM. For each embedded service, the customer application requires only the address of the Service Entry Point (see [14.2.1.3 “Service Entry Point” on page 96](#)).

Even if these services have only one entry point (`AT91F_Open_<Service>` function), they must be specified to the linker. The Embedded Software Services solve this problem by providing a dedicated service: the ROM Entry Service.

The goal of this product-dedicated service is to provide just one address to access all ROM functionalities.

14.3.2 ROM Entry Service

The ROM Entry Service of a product is a structure named `AT91S_RomBoot`. Some members of this structure point to the open functions of all services stored in ROM (function `AT91F_Open_<Service>`) but also the CRC and Sine Arrays. Thus, only the address of the `AT91S_RomBoot` has to be published.

Table 14-3. Initialization of the ROM Entry Service and Use with an Open Service Method

Application Memory Space	ROM Memory Space
<pre>// Init the ROM Entry Service AT91S_RomBoot const *pAT91; pAT91 = AT91C_ROM_BOOT_ADDRESS; // Allocation of the service structure AT91S_CtlTempo tempo;</pre>	<pre>AT91S_TempoStatus AT91F_OpenCtlTempo(AT91PS_CtlTempo pCtlTempo, void const *pTempoTimer) { ... }</pre>
<pre>// Call the Service Open method pAT91->OpenCtlTempo(&tempo, ...); // Use of tempo methods tempo.CtlTempoCreate(&tempo, ...);</pre>	<pre>AT91S_TempoStatus AT91F_CtlTempoCreate (AT91PS_CtlTempo pCtrl, AT91PS_SvcTempo pTempo) { ... }</pre>

The application obtains the address of the ROM Entry Service and initializes an instance of the `AT91S_RomBoot` structure. To obtain the Open Service Method of another service stored in ROM, the application uses the appropriate member of the `AT91S_RomBoot` structure.

The address of the `AT91S_RomBoot` can be found at the beginning of the ROM, after the exception vectors.

14.3.3 Tempo Service

14.3.3.1 Presentation

The Tempo Service allows a single hardware system timer to support several software timers running concurrently. This works as an object notifier.

There are two objects defined to control the Tempo Service: **AT91S_CtlTempo** and **AT91S_SvcTempo**.

The application declares one instance of **AT91S_CtlTempo** associated with the hardware system timer. Additionally, it controls a list of instances of **AT91S_SvcTempo**.

Each time the application requires another timer, it asks the **AT91S_CtlTempo** to create a new instance of **AT91S_SvcTempo**, then the application initializes all the settings of **AT91S_SvcTempo**.

14.3.3.2 Tempo Service Description

Table 14-4. Tempo Service Methods

Associated Function Pointers & Methods Used by Default	Description
<pre>// Typical Use: pAT91->OpenCtlTempo(...); // Default Method: AT91S_TempoStatus AT91F_OpenCtlTempo(AT91PS_CtlTempo pCtlTempo, void const *pTempoTimer)</pre>	<p>Member of AT91S_RomBoot structure. Corresponds to the Open Service Method for the Tempo Service.</p> <p>Input Parameters: Pointer on a Control Tempo Object. Pointer on a System Timer Descriptor Structure.</p> <p>Output Parameters: Returns 0 if OpenCtrlTempo successful. Returns 1 if not.</p>
<pre>// Typical Use: AT91S_CtlTempo ctlTempo; ctlTempo.CtlTempoStart(...); // Default Method: AT91S_TempoStatus AT91F_STStart(void * pTimer)</pre>	<p>Member of AT91S_CtlTempo structure. Start of the Hardware System Timer associated.</p> <p>Input Parameters: Pointer on a Void Parameter corresponding to a System Timer Descriptor Structure.</p> <p>Output Parameters: Returns 2.</p>
<pre>// Typical Use: AT91S_CtlTempo ctlTempo; ctlTempo.CtlTempoIsStart(...); // Default Method: AT91S_TempoStatus AT91F_STIsStart(AT91PS_CtlTempo pCtrl)</pre>	<p>Member of AT91S_CtlTempo structure.</p> <p>Input Parameters: Pointer on a Control Tempo Object.</p> <p>Output Parameters: Returns the Status Register of the System Timer.</p>

Table 14-4. Tempo Service Methods (Continued)

Associated Function Pointers & Methods Used by Default	Description
<pre>// Typical Use: AT91S_CtlTempo ctlTempo; ctlTempo.CtlTempoCreate (...); // Default Method: AT91S_TempoStatus AT91F_CtlTempoCreate (AT91PS_CtlTempo pCtrl, AT91PS_SvcTempo pTempo)</pre>	<p>Member of <code>AT91S_CtlTempo</code> structure. Insert a software timer in the <code>AT91S_SvcTempo</code>'s list. Input Parameters: Pointer on a Control Tempo Object. Pointer on a Service Tempo Object to insert. Output Parameters: Returns 0 if the software tempo was created. Returns 1 if not.</p>
<pre>// Typical Use: AT91S_CtlTempo ctlTempo; ctlTempo.CtlTempoRemove (...); // Default Method: AT91S_TempoStatus AT91F_CtlTempoRemove (AT91PS_CtlTempo pCtrl, AT91PS_SvcTempo pTempo)</pre>	<p>Member of <code>AT91S_CtlTempo</code> structure. Remove a software timer in the list. Input Parameters: Pointer on a Control Tempo Object. Pointer on a Service Tempo Object to remove. Output Parameters: Returns 0 if the tempo was created. Returns 1 if not.</p>
<pre>// Typical Use: AT91S_CtlTempo ctlTempo; ctlTempo.CtlTempoTick (...); // Default Method: AT91S_TempoStatus AT91F_CtlTempoTick (AT91PS_CtlTempo pCtrl)</pre>	<p>Member of <code>AT91S_CtlTempo</code> structure. Refresh all the software timers in the list. Update their timeout and check if callbacks have to be launched. So, for example, this function has to be used when the hardware timer starts a new periodic interrupt if period interval timer is used. Input Parameters: Pointer on a Control Tempo Object. Output Parameters: Returns 1.</p>
<pre>// Typical Use: AT91S_SvcTempo svcTempo; svcTempo.Start (...); // Default Method: AT91S_TempoStatus AT91F_SvcTempoStart (AT91PS_SvcTempo pSvc, unsigned int timeout, unsigned int reload, void (*callback) (AT91S_TempoStatus, void *), void *pData)</pre>	<p>Member of <code>AT91S_SvcTempo</code> structure. Start a software timer. Input Parameters: Pointer on a Service Tempo Object. Timeout to apply. Number of times to reload the tempo after timeout completed for periodic execution. Callback on a method to launch once the timeout completed. Allows to have a hook on the current service. Output Parameters: Returns 1.</p>
<pre>// Typical Use: AT91S_SvcTempo svcTempo; svcTempo.Stop (...); // Default Method: AT91S_TempoStatus AT91F_SvcTempoStop (AT91PS_SvcTempo pSvc)</pre>	<p>Member of <code>AT91S_SvcTempo</code> structure. Force to stop a software timer. Input Parameters: Pointer on a Service Tempo Object. Output Parameters: Returns 1.</p>

Note: `AT91S_TempoStatus` corresponds to an unsigned int.

14.3.3.3 Using the Service

The first step is to find the address of the open service method `AT91F_OpenCtlTempo` using the ROM Entry Service.

Allocate one instance of `AT91S_CtlTempo` and `AT91S_SvcTempo` in the application memory space:

```
// Allocate the service and the control tempo
AT91S_CtlTempo ctlTempo;
AT91S_SvcTempo svcTempo1;
```

Initialize the `AT91S_CtlTempo` instance by calling the `AT91F_OpenCtlTempo` function:

```
// Initialize service
pAT91->OpenCtlTempo(&ctlTempo, (void *) &(pAT91->SYSTIMER_DESC));
```

At this stage, the application can use the `AT91S_CtlTempo` service members.

If the application wants to overload an object member, it can be done now. For example, if `AT91F_CtlTempoCreate(&ctlTempo, &svcTempo1)` method is to be replaced by the application defined as `my_CtlTempoCreate(...)`, the procedure is as follows:

```
// Overload AT91F_CtlTempoCreate
ctlTempo.CtlTempoCreate = my_CtlTempoCreate;
```

In most cases, initialize the `AT91S_SvcTempo` object by calling the `AT91F_CtlTempoCreate` method of the `AT91S_CtlTempo` service:

```
// Init the svcTempo1, link it to the AT91S_CtlTempo object
ctlTempo.CtlTempoCreate(&ctlTempo, &svcTempo1);
```

Start the timeout by calling `start` method of the `svcTempo1` object. Depending on the function parameters, either a callback is started at the end of the countdown or the status of the timeout is checked by reading the `TickTempo` member of the `svcTempo1` object.

```
// Start the timeout
svcTempo1.Start(&svcTempo1, 100, 0, NULL, NULL);
// Wait for the timeout of 100 (unity depends on the timer programming)
// No repetition and no callback.
while (svcTempo1.TickTempo);
```

When the application needs another software timer to control a timeout, it:

- Allocates one instance of `AT91S_SvcTempo` in the application memory space

```
// Allocate the service
AT91S_SvcTempo svcTempo2;
```

- Initializes the `AT91S_SvcTempo` object calling the `AT91F_CtlTempoCreate` method of the `AT91S_CtlTempo` service:

```
// Init the svcTempo2, link it to the AT91S_CtlTempo object
ctlTempo.CtlTempoCreate(&ctlTempo, &svcTempo2);
```

14.3.4 Xmodem Service

14.3.4.1 Presentation

The Xmodem service is an application of the communication pipe abstract layer. This layer is media-independent (USART, USB, etc.) and gives entry points to carry out reads and writes on an abstract media, the pipe.

Communication Pipe Service

The pipe communication structure is a virtual structure that contains all the functions required to read and write a buffer, regardless of the communication media and the memory management.

The pipe structure defines:

- a pointer to a communication service structure `AT91PS_SvcComm`
- a pointer to a buffer manager structure `AT91PS_Buffer`
- pointers on read and write functions
- pointers to callback functions associated to the read and write functions

The following structure defines the pipe object:

```
typedef struct _AT91S_Pipe
{
    // A pipe is linked with a peripheral and a buffer
    AT91PS_SvcComm pSvcComm;
    AT91PS_Buffer  pBuffer;

    // Callback functions with their arguments
    void (*WriteCallback) (AT91S_PipeStatus, void *);
    void (*ReadCallback)  (AT91S_PipeStatus, void *);
    void *pPrivateReadData;
    void *pPrivateWriteData;

    // Pipe methods
    AT91S_PipeStatus (*Write) (
        struct _AT91S_Pipe *pPipe,
        char const *      pData,
        unsigned int      size,
        void               (*callback) (AT91S_PipeStatus, void *),
        void               *privateData);
    AT91S_PipeStatus (*Read) (
        struct _AT91S_Pipe *pPipe,
        char               *pData,
        unsigned int       size,
        void               (*callback) (AT91S_PipeStatus, void *),
        void               *privateData);
    AT91S_PipeStatus (*AbortWrite) (struct _AT91S_Pipe *pPipe);
    AT91S_PipeStatus (*AbortRead)  (struct _AT91S_Pipe *pPipe);
    AT91S_PipeStatus (*Reset)     (struct _AT91S_Pipe *pPipe);
};
```

```

char (*IsWritten) (struct _AT91S_Pipe *pPipe,char const *pVoid);
char (*IsReceived) (struct _AT91S_Pipe *pPipe,char const *pVoid);
} AT91S_Pipe, *AT91PS_Pipe;

```

The Xmodem protocol implementation demonstrates how to use the communication pipe.

Description of the Buffer Structure

The AT91PS_Buffer is a pointer to the AT91S_Buffer structure manages the buffers. This structure embeds the following functions:

- pointers to functions that manage the read buffer
- pointers to functions that manage the write buffer

All the functions can be overloaded by the application to adapt buffer management.

A simple implementation of buffer management for the **Xmodem Service** is provided in the boot ROM source code.

```

typedef struct _AT91S_Buffer
{
    struct _AT91S_Pipe *pPipe;
    void *pChild;

    // Functions invoked by the pipe
    AT91S_BufferStatus (*SetRdBuffer)      (struct _AT91S_Buffer *pSBuffer,
char *pBuffer, unsigned int Size);
    AT91S_BufferStatus (*SetWrBuffer)      (struct _AT91S_Buffer *pSBuffer,
char const *pBuffer, unsigned int Size);
    AT91S_BufferStatus (*RstRdBuffer)      (struct _AT91S_Buffer *pSBuffer);
    AT91S_BufferStatus (*RstWrBuffer)      (struct _AT91S_Buffer *pSBuffer);
    char (*MsgWritten)      (struct _AT91S_Buffer *pSBuffer, char const
*pBuffer);
    char (*MsgRead)      (struct _AT91S_Buffer *pSBuffer, char const
*pBuffer);

    // Functions invoked by the peripheral
    AT91S_BufferStatus (*GetWrBuffer)      (struct _AT91S_Buffer *pSBuffer,
char const **pData, unsigned int *pSize);
    AT91S_BufferStatus (*GetRdBuffer)      (struct _AT91S_Buffer *pSBuffer,
char **pData, unsigned int *pSize);
    AT91S_BufferStatus (*EmptyWrBuffer)    (struct _AT91S_Buffer *pSBuffer,
unsigned int size);
    AT91S_BufferStatus (*FillRdBuffer)     (struct _AT91S_Buffer *pSBuffer,
unsigned int size);
    char (*IsWrEmpty)      (struct _AT91S_Buffer *pSBuffer);
    char (*IsRdFull)      (struct _AT91S_Buffer *pSBuffer);
} AT91S_Buffer, *AT91PS_Buffer;

```

Description of the SvcComm Structure

The SvcComm structure provides the interface between low-level functions and the pipe object.

It contains pointers of functions initialized to the lower level functions (e.g. SvcXmodem).

The Xmodem Service implementation gives an example of SvcComm use.

```
typedef struct _AT91S_Service
{
    // Methods:
    AT91S_SvcCommStatus (*Reset) (struct _AT91S_Service *pService);
    AT91S_SvcCommStatus (*StartTx) (struct _AT91S_Service *pService);
    AT91S_SvcCommStatus (*StartRx) (struct _AT91S_Service *pService);
    AT91S_SvcCommStatus (*StopTx) (struct _AT91S_Service *pService);
    AT91S_SvcCommStatus (*StopRx) (struct _AT91S_Service *pService);
    char (*TxReady) (struct _AT91S_Service *pService);
    char (*RxReady) (struct _AT91S_Service *pService);
    // Data:
    struct _AT91S_Buffer *pBuffer; // Link to a buffer object
    void *pChild;
} AT91S_SvcComm, *AT91PS_SvcComm;
```

Description of the SvcXmodem Structure

The SvcXmodem service is a reusable implementation of the Xmodem protocol. It supports only the 128-byte packet format and provides read and write functions. The SvcXmodem structure defines:

- a pointer to a handler initialized to readHandler or writeHandler
- a pointer to a function that processes the xmodem packet crc
- a pointer to a function that checks the packet header
- a pointer to a function that checks data

With this structure, the Xmodem protocol can be used with all media (USART, USB, etc.). Only private methods may be overloaded to adapt the Xmodem protocol to a new media.

The default implementation of the Xmodem uses a USART to send and receive packets. Read and write functions implement Peripheral DMA Controller facilities to reduce interrupt overhead. It assumes the USART is initialized, the memory buffer allocated and the interrupts programmed.

A periodic timer is required by the service to manage timeouts and the periodic transmission of the character "C" (Refer to Xmodem protocol). This feature is provided by the Tempo Service.

The following structure defines the Xmodem Service:

```
typedef struct _AT91PS_SvcXmodem {

    // Public Methods:
    AT91S_SvcCommStatus (*Handler) (struct _AT91PS_SvcXmodem *, unsigned int);
    AT91S_SvcCommStatus (*StartTx) (struct _AT91PS_SvcXmodem *, unsigned int);
    AT91S_SvcCommStatus (*StopTx) (struct _AT91PS_SvcXmodem *, unsigned int);

    // Private Methods:
    AT91S_SvcCommStatus (*ReadHandler) (struct _AT91PS_SvcXmodem *, unsigned
int csr);
```



```
    AT91S_SvcCommStatus (*WriteHandler) (struct _AT91PS_SvcXmodem *, unsigned
int csr);
    unsigned short      (*GetCrc)        (char *ptr, unsigned int count);
    char                (*CheckHeader)   (unsigned char currentPacket, char
*packet);
    char                (*CheckData)     (struct _AT91PS_SvcXmodem *);

    AT91S_SvcComm parent;                // Base class
    AT91PS_USART pUsart;

    AT91S_SvcTempo tempo; // Link to a AT91S_Tempo object

    char                *pData;
    unsigned int        dataSize;         // = XMODEM_DATA_STX or XMODEM_DATA_SOH
    char                packetDesc[AT91C_XMODEM_PACKET_SIZE];
    unsigned char       packetId;        // Current packet
    char                packetStatus;
    char                isPacketDesc;
    char                eot;             // end of transmittion
} AT91S_SvcXmodem, *AT91PS_SvcXmodem
```

14.3.4.2 Xmodem Service Description

Table 14-5. Xmodem Service Methods

Associated Function Pointers & Methods Used by Default	Description
<pre>// Typical Use: pAT91->OpenSvcXmodem(...); // Default Method: AT91PS_SvcComm AT91F_OpenSvcXmodem(AT91PS_SvcXmodem pSvcXmodem, AT91PS_USART pUsart, AT91PS_CtlTempo pCtlTempo)</pre>	<p>Member of <code>AT91S_RomBoot</code> structure.</p> <p>Corresponds to the Open Service Method for the Xmodem Service.</p> <p>Input Parameters:</p> <ul style="list-style-type: none"> Pointer on <code>SvcXmodem</code> structure. Pointer on a <code>USART</code> structure. Pointer on a <code>CtlTempo</code> structure. <p>Output Parameters:</p> <p>Returns the Xmodem Service Pointer Structure.</p>
<pre>// Typical Use: AT91S_SvcXmodem svcXmodem; svcXmodem.Handler(...); // Default read handler: AT91S_SvcCommStatus AT91F_SvcXmodemReadHandler(AT91PS_SvcXmodem pSvcXmodem, unsigned int csr) // Default write handler: AT91S_SvcCommStatus AT91F_SvcXmodemWriteHandler(AT91PS_SvcXmodem pSvcXmodem, unsigned int csr)</pre>	<p>Member of <code>AT91S_SvcXmodem</code> structure.</p> <p>interrupt handler for xmodem read or write functionalities</p> <p>Input Parameters:</p> <ul style="list-style-type: none"> Pointer on a Xmodem Service Structure. csr: usart channel status register. <p>Output Parameters:</p> <p>Status for xmodem read or write.</p>

14.3.4.3 Using the Service

The following steps show how to initialize and use the Xmodem Service in an application:

```
Variables definitions:
AT91S_RomBoot const *pAT91; // struct containing Openservice functions
AT91S_SBuffer    sXmBuffer; // Xmodem Buffer allocation
AT91S_SvcXmodem svcXmodem; // Xmodem service structure allocation
AT91S_Pipe       xmodemPipe; // xmodem pipe communication struct
AT91S_CtlTempo  ctlTempo; // Tempo struct
AT91PS_Buffer   pXmBuffer; // Pointer on a buffer structure
AT91PS_SvcComm  pSvcXmodem; // Pointer on a Media Structure

Initialisations
// Call Open methods:
pAT91 = AT91C_ROM_BOOT_ADDRESS;
// OpenCtlTempo on the system timer
pAT91->OpenCtlTempo(&ctlTempo, (void *) &(pAT91->SYSTIMER_DESC));
ctlTempo.CtlTempoStart((void *) &(pAT91->SYSTIMER_DESC));
// Xmodem buffer initialisation
pXmBuffer = pAT91->OpenSBuffer(&sXmBuffer);
```

```

pSvcXmodem = pAT91->OpenSvcXmodem(&svcXmodem, AT91C_BASE_DBGU, &ctlTempo);
// Open communication pipe on the xmodem service
pAT91->OpenPipe(&xmodemPipe, pSvcXmodem, pXmBuffer);
// Init the DBGU peripheral
// Open PIO for DBGU
AT91F_DBGU_CfgPIO();
// Configure DBGU
AT91F_US_Configure (
    (AT91PS_USART) AT91C_BASE_DBGU,      // DBGU base address
    MCK,                                // Master Clock
    AT91C_US_ASYNC_MODE,                // mode Register to be programmed
    BAUDRATE ,                          // baudrate to be programmed
    0);                                  // timeguard to be programmed
// Enable Transmitter
AT91F_US_EnableTx((AT91PS_USART) AT91C_BASE_DBGU);
// Enable Receiver
AT91F_US_EnableRx((AT91PS_USART) AT91C_BASE_DBGU);
// Initialize the Interrupt for System Timer and DBGU (shared interrupt)
// Initialize the Interrupt Source 1 for SysTimer and DBGU
AT91F_AIC_ConfigureIt(AT91C_BASE_AIC,
    AT91C_ID_SYS,
    AT91C_AIC_PRIOR_HIGHEST,
    AT91C_AIC_SRCTYPE_INT_LEVEL_SENSITIVE,
    AT91F_ASM_ST_DBGU_Handler);

// Enable SysTimer and DBGU interrupt
AT91F_AIC_EnableIt(AT91C_BASE_AIC, AT91C_ID_SYS);

xmodemPipe.Read(&xmodemPipe, (char *) BASE_LOAD_ADDRESS, MEMORY_SIZE,
XmodemProtocol, (void *) BASE_LOAD_ADDRESS);

```

14.3.5 DataFlash Service

14.3.5.1 Presentation

The DataFlash Service allows the Serial Peripheral Interface (SPI) to support several Serial DataFlash and DataFlash Cards for reading, programming and erasing operations.

This service is based on SPI interrupts that are managed by a specific handler. It also uses the corresponding PDC registers.

For more information on the commands available in the DataFlash Service, refer to the relevant DataFlash documentation.

14.3.5.2 DataFlash Service Description

Table 14-6. DataFlash Service Methods

Associated Function Pointers & Methods Used by Default	Description
<pre>// Typical Use: pAT91->OpenSvcDataFlash(...); // Default Method: AT91PS_SvcDataFlash AT91F_OpenSvcDataFlash (const AT91PS_PMC pApmc, AT91PS_SvcDataFlash pSvcDataFlash)</pre>	<p>Member of <code>AT91S_RomBoot</code> structure.</p> <p>Corresponds to the Open Service Method for the DataFlash Service.</p> <p>Input Parameters:</p> <p>Pointer on a PMC Register Description Structure.</p> <p>Pointer on a DataFlash Service Structure.</p> <p>Output Parameters:</p> <p>Returns the DataFlash Service Pointer Structure.</p>
<pre>// Typical Use: AT91S_SvcDataFlash svcDataFlash; svcDataFlash.Handler(...); // Default Method: void AT91F_DataFlashHandler (AT91PS_SvcDataFlash pSvcDataFlash, unsigned int status)</pre>	<p>Member of <code>AT91S_SvcDataFlash</code> structure.</p> <p>SPI Fixed Peripheral C interrupt handler.</p> <p>Input Parameters:</p> <p>Pointer on a DataFlash Service Structure.</p> <p>Status: corresponds to the interruptions detected and validated on SPI (SPI Status Register masked by SPI Mask Register).</p> <p>Has to be put in the Interrupt handler for SPI.</p> <p>Output Parameters:</p> <p>None.</p>
<pre>// Typical Use: AT91S_SvcDataFlash svcDataFlash; svcDataFlash.Status(...); // Default Method: AT91S_SvcDataFlashStatus AT91F_DataFlashGetStatus(AT91PS_DataflashDesc pDesc)</pre>	<p>Member of <code>AT91S_SvcDataFlash</code> structure.</p> <p>Read the status register of the DataFlash.</p> <p>Input Parameters:</p> <p>Pointer on a DataFlash Descriptor Structure (member of the service structure).</p> <p>Output Parameters:</p> <p>Returns 0 if DataFlash is Busy.</p> <p>Returns 1 if DataFlash is Ready.</p>
<pre>// Typical Use: AT91S_SvcDataFlash svcDataFlash; svcDataFlash.AbortCommand(...); // Default Method: void AT91F_DataFlashAbortCommand(AT91PS_DataflashDesc pDesc)</pre>	<p>Member of <code>AT91S_SvcDataFlash</code> structure</p> <p>Allows to reset PDC & Interrupts.</p> <p>Input Parameters:</p> <p>Pointer on a DataFlash Descriptor Structure (member of the service structure).</p> <p>Output Parameters:</p> <p>None.</p>

Table 14-6. DataFlash Service Methods (Continued)

Associated Function Pointers & Methods Used by Default	Description
<pre>// Typical Use: AT91S_SvcDataFlash svcDataFlash; svcDataFlash.PageRead(...); // Default Method: AT91S_SvcDataFlashStatus AT91F_DataFlashPageRead (AT91PS_SvcDataFlash pSvcDataFlash, unsigned int src, unsigned char *dataBuffer, int sizeToRead)</pre>	<p>Member of <code>AT91S_SvcDataFlash</code> structure Read a Page in DataFlash. Input Parameters: Pointer on DataFlash Service Structure. DataFlash address. Data buffer destination pointer. Number of bytes to read. Output Parameters: Returns 0 if DataFlash is Busy. Returns 1 if DataFlash Ready.</p>
<pre>// Typical Use: AT91S_SvcDataFlash svcDataFlash; svcDataFlash.ContinuousRead(...); // Default Method: AT91S_SvcDataFlashStatus AT91F_DataFlashContinuousRead (AT91PS_SvcDataFlash pSvcDataFlash, int src, unsigned char *dataBuffer, int sizeToRead)</pre>	<p>Member of <code>AT91S_SvcDataFlash</code> structure. Continuous Stream Read. Input Parameters: Pointer on DataFlash Service Structure. DataFlash address. Data buffer destination pointer. Number of bytes to read. Output Parameters: Returns 0 if DataFlash is Busy. Returns 1 if DataFlash is Ready.</p>
<pre>// Typical Use: AT91S_SvcDataFlash svcDataFlash; svcDataFlash.ReadBuffer(...); // Default Method: AT91S_SvcDataFlashStatus AT91F_DataFlashReadBuffer (AT91PS_SvcDataFlash pSvcDataFlash, unsigned char BufferCommand, unsigned int bufferAddress, unsigned char *dataBuffer, int sizeToRead)</pre>	<p>Member of <code>AT91S_SvcDataFlash</code> structure. Read the Internal DataFlash SRAM Buffer 1 or 2. Input Parameters: Pointer on DataFlash Service Structure. Choose Internal DataFlash Buffer 1 or 2 command. DataFlash address. Data buffer destination pointer. Number of bytes to read. Output Parameters: Returns 0 if DataFlash is Busy. Returns 1 if DataFlash is Ready. Returns 4 if DataFlash Bad Command. Returns 5 if DataFlash Bad Address.</p>

Table 14-6. DataFlash Service Methods (Continued)

Associated Function Pointers & Methods Used by Default	Description
<pre>// Typical Use: AT91S_SvcDataFlash svcDataFlash; svcDataFlash.MainMemoryToBufferTransfert(...); // Default Method: AT91S_SvcDataFlashStatus AT91F_MainMemoryToBufferTransfert(AT91PS_SvcDataFlash pSvcDataFlash, unsigned char BufferCommand, unsigned int page)</pre>	<p>Member of <code>AT91S_SvcDataFlash</code> structure</p> <p>Read a Page in the Internal SRAM Buffer 1 or 2.</p> <p>Input Parameters:</p> <ul style="list-style-type: none"> Pointer on DataFlash Service Structure. Choose Internal DataFlash Buffer 1 or 2 command. Page to read. <p>Output Parameters:</p> <ul style="list-style-type: none"> Returns 0 if DataFlash is Busy. Returns 1 if DataFlash is Ready. Returns 4 if DataFlash Bad Command.
<pre>// Typical Use: AT91S_SvcDataFlash svcDataFlash; svcDataFlash.PagePgmBuf(...); // Default Method: AT91S_SvcDataFlashStatus AT91F_DataFlashPagePgmBuf(AT91PS_SvcDataFlash pSvcDataFlash, unsigned char BufferCommand, unsigned char *src, unsigned int dest, unsigned int SizeToWrite)</pre>	<p>Member of <code>AT91S_SvcDataFlash</code> structure</p> <p>Page Program through Internal SRAM Buffer 1 or 2.</p> <p>Input Parameters:</p> <ul style="list-style-type: none"> Pointer on DataFlash Service Structure. Choose Internal DataFlash Buffer 1 or 2 command. Source buffer. DataFlash destination address. Number of bytes to write. <p>Output Parameters:</p> <ul style="list-style-type: none"> Returns 0 if DataFlash is Busy. Returns 1 if DataFlash is Ready. Returns 4 if DataFlash Bad Command.
<pre>// Typical Use: AT91S_SvcDataFlash svcDataFlash; svcDataFlash.WriteBuffer(...); // Default Method: AT91S_SvcDataFlashStatus AT91F_DataFlashWriteBuffer (AT91PS_SvcDataFlash pSvcDataFlash, unsigned char BufferCommand, unsigned char *dataBuffer, unsigned int bufferAddress, int SizeToWrite)</pre>	<p>Member of <code>AT91S_SvcDataFlash</code> structure.</p> <p>Write data to the Internal SRAM buffer 1 or 2.</p> <p>Input Parameters:</p> <ul style="list-style-type: none"> Pointer on DataFlash Service Structure. Choose Internal DataFlash Buffer 1 or 2 command. Pointer on data buffer to write. Address in the internal buffer. Number of bytes to write. <p>Output Parameters:</p> <ul style="list-style-type: none"> Returns 0 if DataFlash is Busy. Returns 1 if DataFlash is Ready. Returns 4 if DataFlash Bad Command. Returns 5 if DataFlash Bad Address.

Table 14-6. DataFlash Service Methods (Continued)

Associated Function Pointers & Methods Used by Default	Description
<pre>// Typical Use: AT91S_SvcDataFlash svcDataFlash; svcDataFlash.WriteBufferToMain(...); // Default Method: AT91S_SvcDataFlashStatus AT91F_WriteBufferToMain (AT91PS_SvcDataFlash pSvcDataFlash, unsigned char BufferCommand, unsigned int dest)</pre>	<p>Member of <code>AT91S_SvcDataFlash</code> structure.</p> <p>Write Internal Buffer to the DataFlash Main Memory.</p> <p>Input Parameters:</p> <p>Pointer on DataFlash Service Structure.</p> <p>Choose Internal DataFlash Buffer 1 or 2 command.</p> <p>Main memory address on DataFlash.</p> <p>Output Parameters:</p> <p>Returns 0 if DataFlash is Busy.</p> <p>Returns 1 if DataFlash is Ready.</p>
<pre>// Typical Use: AT91S_SvcDataFlash svcDataFlash; svcDataFlash.PageErase(...); // Default Method: AT91S_SvcDataFlashStatus AT91F_PageErase (AT91PS_SvcDataFlash pSvcDataFlash, unsigned int PageNumber)</pre>	<p>Member of <code>AT91S_SvcDataFlash</code> structure.</p> <p>Erase a page in DataFlash.</p> <p>Input Parameters:</p> <p>Pointer on a Service DataFlash Object.</p> <p>Page to erase.</p> <p>Output Parameters:</p> <p>Returns 0 if DataFlash is Busy.</p> <p>Returns 1 if DataFlash Ready.</p>
<pre>// Typical Use: AT91S_SvcDataFlash svcDataFlash; svcDataFlash.BlockErase(...); // Default Method: AT91S_SvcDataFlashStatus AT91F_BlockErase (AT91PS_SvcDataFlash pSvcDataFlash, unsigned int BlockNumber)</pre>	<p>Member of <code>AT91S_SvcDataFlash</code> structure.</p> <p>Erase a block of 8 pages.</p> <p>Input Parameters:</p> <p>Pointer on a Service DataFlash Object.</p> <p>Block to erase.</p> <p>Output Parameters:</p> <p>Returns 0 if DataFlash is Busy.</p> <p>Returns 1 if DataFlash Ready.</p>
<pre>// Typical Use: AT91S_SvcDataFlash svcDataFlash; svcDataFlash.MainMemoryToBufferCompare(...); // Default Method: AT91S_SvcDataFlashStatus AT91F_MainMemoryToBufferCompare (AT91PS_SvcDataFlash pSvcDataFlash, unsigned char BufferCommand, unsigned int page)</pre>	<p>Member of <code>AT91S_SvcDataFlash</code> structure.</p> <p>Compare the contents of a Page and one of the Internal SRAM buffer.</p> <p>Input Parameters:</p> <p>Pointer on a Service DataFlash Object.</p> <p>Internal SRAM DataFlash Buffer to compare command.</p> <p>Page to compare.</p> <p>Output Parameters:</p> <p>Returns 0 if DataFlash is Busy.</p> <p>Returns 1 if DataFlash Ready.</p> <p>Returns 4 if DataFlash Bad Command.</p>

Note: `AT91S_SvcDataFlashStatus` corresponds to an unsigned int.

14.3.5.3 Using the Service

The first step is to find the address of the open service method `AT91F_OpenSvcDataFlash` using the ROM Entry Service.

1. Allocate one instance of `AT91S_SvcDataFlash` and `AT91S_Dataflash` in the application memory space:

```
// Allocate the service and a device structure.
AT91S_SvcDataFlash svcDataFlash;
AT91S_Dataflash Device; // member of AT91S_SvcDataFlash service
```

Then initialize the `AT91S_SvcDataFlash` instance by calling the `AT91F_OpenSvcDataFlash` function:

```
// Initialize service
pAT91->OpenSvcDataFlash (AT91C_BASE_PMC, &svcDataFlash);
```

2. Initialize the SPI Interrupt:

```
// Initialize the SPI Interrupt
at91_irq_open ( AT91C_BASE_AIC,AT91C_ID_SPI,3,
               AT91C_AIC_SRCTYPE_INT_LEVEL_SENSITIVE
               ,AT91F_spi_asm_handler);
```

3. Configure the DataFlash structure with its correct features and link it to the device structure in the `AT91S_SvcDataFlash` service structure:

```
// Example with an ATMEL AT45DB321B DataFlash
Device.pages_number = 8192;
Device.pages_size = 528;
Device.page_offset = 10;
Device.byte_mask = 0x300;
// Link to the service structure
svcDataFlash.pDevice = &Device;
```

4. Now the different methods can be used. Following is an example of a Page Read of 528 bytes on page 50:

```
// Result of the read operation in RxBufferDataFlash
unsigned char RxBufferDataFlash[528];
svcDataFlash.PageRead(&svcDataFlash,
                    (50*528),RxBufferDataFlash,528);
```

14.3.6 CRC Service

14.3.6.1 Presentation

This “service” differs from the preceding ones in that it is structured differently: it is composed of an array and some methods directly accessible via the `AT91S_RomBoot` structure.

14.3.6.2 CRC Service Description

Table 14-7. CRC Service Description

Methods and Array Available	Description
<pre>// Typical Use: pAT91->CRC32(...); // Default Method: void CalculateCrc32(const unsigned char *address, unsigned int size, unsigned int *crc)</pre>	<p>This function provides a table driven 32bit CRC generation for byte data. This CRC is known as the CCITT CRC32.</p> <p>Input Parameters: Pointer on the data buffer. The size of this buffer. A pointer on the result of the CRC.</p> <p>Output Parameters: None.</p>
<pre>// Typical Use: pAT91->CRC16(...); // Default Method: void CalculateCrc16(const unsigned char *address, unsigned int size, unsigned short *crc)</pre>	<p>This function provides a table driven 16bit CRC generation for byte data. This CRC is calculated with the POLYNOME 0x8005</p> <p>Input Parameters: Pointer on the data buffer. The size of this buffer. A pointer on the result of the CRC.</p> <p>Output Parameters: None.</p>
<pre>// Typical Use: pAT91->CRCHDLC(...); // Default Method: void CalculateCrcHdlc(const unsigned char *address, unsigned int size, unsigned short *crc)</pre>	<p>This function provides a table driven 16bit CRC generation for byte data. This CRC is known as the HDLC CRC.</p> <p>Input Parameters: Pointer on the data buffer. The size of this buffer. A pointer on the result of the CRC.</p> <p>Output Parameters: None.</p>
<pre>// Typical Use: pAT91->CRCCCITT(...); // Default Method: void CalculateCrc16ccitt(const unsigned char *address, unsigned int size, unsigned short *crc)</pre>	<p>This function provides a table driven 16bit CRC generation for byte data. This CRC is known as the CCITT CRC16 (POLYNOME = 0x1021).</p> <p>Input Parameters: Pointer on the data buffer. The size of this buffer. A pointer on the result of the CRC.</p> <p>Output Parameters: None.</p>

Table 14-7. CRC Service Description (Continued)

Methods and Array Available	Description
<pre>// Typical Use: char reverse_byte; reverse_byte = pAT91-> >Bit_Reverse_Array[...]; // Array Embedded: const unsigned char bit_rev[256]</pre>	<p>Bit Reverse Array: array which allows to reverse one octet. Frequently used in mathematical algorithms.</p> <p>Used for example in the CRC16 calculation.</p>

14.3.6.3 Using the Service

Compute the CRC16 CCITT of a 256-byte buffer and save it in the `crc16` variable:

```
// Compute CRC16 CCITT
unsigned char BufferToCompute[256];
short crc16;
... (BufferToCompute Treatment)
pAT91->CRCCITT(&BufferToCompute, 256, &crc16);
```

14.3.7 Sine Service

14.3.7.1 Presentation

This “service” differs from the preceding one in that it is structured differently: it is composed of an array and a method directly accessible through the `AT91S_RomBoot` structure.

14.3.7.2 Sine Service Description

Table 14-8. Sine Service Description

Method and Array Available	Description
<pre>// Typical Use: pAT91->Sine(...); // Default Method: short AT91F_Sinus(int step)</pre>	<p>This function returns the amplitude coded on 16 bits, of a sine waveform for a given step.</p> <p>Input Parameters:</p> <p>Step of the sine. Corresponds to the precision of the amplitude calculation. Depends on the Sine Array used. Here, the array has 256 values (thus 256 steps) of amplitude for 180 degrees.</p> <p>Output Parameters:</p> <p>Amplitude of the sine waveform.</p>
<pre>// Typical Use: short sinus; sinus = pAT91->SineTab[...]; // Array Embedded: const short AT91C_SINUS180_TAB[256]</pre>	<p>Sine Array with a resolution of 256 values for 180 degrees.</p>



15. AT91RM9200 Reset Controller

15.1 Overview

This chapter describes the AT91RM9200 reset signals and how to use them in order to assure correct operation of the device.

The AT91RM9200 has two reset input lines called NRST and NTRST. Each line provides, respectively:

- Initialization of the User Interface registers (defined in the user interface of each peripheral) and:
 - Sample the signals needed at bootup
 - Compel the processor to fetch the next instruction at address zero.
- Initialization of the embedded ICE TAP controller.

The NRST signal must be considered as the System Reset signal and the reader must take care when designing the logic to drive this reset signal. NTRST is typically used by the hardware debug interface which uses the In-Circuit Emulator unit and Initializes it without affecting the normal operation of the ARM® processor. This line shall also be driven by an on board logic.

Both NRST and NTRST are active low signals that asynchronously reset the logic in the AT91RM9200.

15.1.1 Reset Conditions

15.1.1.1 NRST Conditions

NRST is the active low reset input. When power is first applied to the system, a power-on reset (also denominated as “cold” reset) must be applied to the AT91RM9200. During this transient state, it is mandatory to hold the reset signal low long enough for the power supply to reach a working nominal level and for the oscillator to reach a stable operating frequency. Typically, these features are provided by every power supply supervisor which, under a threshold voltage limit, the electrical environment is considered as not nominal. Power-up is not the only event to be considered as power-down or a brownout are also occurrences that assert the NRST signal. The threshold voltage must be selected according to the minimum operating voltage of the AT91RM9200 power supply lines marked as VDD in [Figure 15-1](#). (See [Section 37.2 “DC Characteristics”](#) on page 632.)

The choice of the reset holding delay depends on the start-up time of the low frequency oscillator as shown below in [Figure 15-1](#). (See [Section 37.4.1 “32 kHz Oscillator Characteristics”](#) on page 633.)

Figure 15-1. Cold Reset and Oscillator Start-up relationship

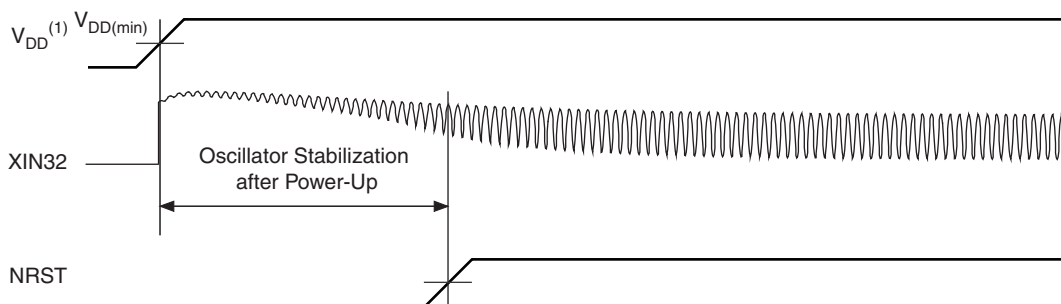

Note: 1. VDD is applicable to VDDIOM, VDDIOP, VDDPLL, VDDOSC and VDDCORE
 NRST can also be asserted in circumstances other than the power-up sequence, such as a manual command. This assertion can be performed asynchronously, but exit from reset is synchronized internally to the default active clock. During normal operation, NRST must be active for a minimum delay time to ensure correct behavior. See [Figure 15-2](#) and [Table 15-1](#).

Table 15-1. Reset Minimum Pulse Width

Symbol	Parameter	Min. Pulse Width	Unit
RST1	NRST Minimum Pulse Width	92	μs

Figure 15-2. NRST assertion

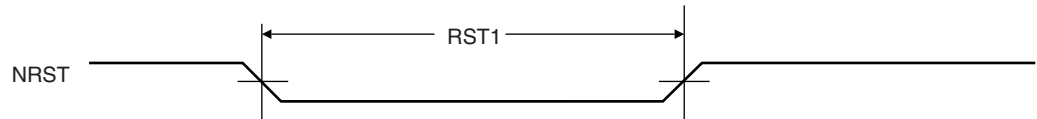

15.1.1.2 NTRST Assertion

As with the NRST signal, at power-up, the NTRST signal must be valid while the power supply has not obtained the minimum recommended working level. A clock on TCK is not required to validate this reset request.

As with the NRST signal, NTRST can also be asserted in circumstances other than the power-up sequence, such as a manual command or an ICE Interface action. This assertion and de-assertion can be performed asynchronously but must be active for a minimum delay time. (See [Section 38.3 "JTAG/ICE Timings" on page 657.](#))

15.1.2 Reset Management

15.1.2.1 System Reset

The system reset functionality is provided through the NRST signal.

This Reset signal is used to compel the microcontroller unit to assume a set of initial conditions:

- Sample the Boot Mode Select (BMS) logical state.
- Restore the default states (default values) of the user interface.
- Require the processor to perform the next instruction fetch from address zero.

With the exception of the program counter and the Current Program Status Register, the processor's registers do not have defined reset states. When the microcontroller's NRST input is asserted, the processor immediately stops execution of the current instruction independently of the clock.

The system reset circuitry must take two types of reset requests into account:

- The cold reset needed for the power-up sequence.
- The user reset request.

Both have the same effect but can have different assertion time requirements regarding the NRST pin. In fact, the cold reset assertion has to overlap the start-up time of the system. The user reset request requires a shorter assertion delay time than does cold reset.

15.1.2.2 Test Access Port (TAP) Reset

Test Access Port (TAP) reset functionality is provided through the NTRST signal.

The NTRST control pin initializes the selected TAP controller. The TAP controller involved in this reset is determined according to the initial logical state applied on the JTAGSEL pin after the last valid NRST.

In Boundary Scan Mode, after a NTRST assertion, the IDCODE instruction is set onto the output of the instruction register in the Test-Logic-Reset controller state.

Otherwise, in ICE Mode, the reset action is as follows:

- The core exits from Debug Mode.
- The IDCORE instruction is requested.

In either Boundary Scan or ICE Mode a reset can be performed from the same or different circuitry, as shown in [Figure 15-3](#) below, upon system reset at power-up or upon user request.

Figure 15-3. Separate or Common Reset Management

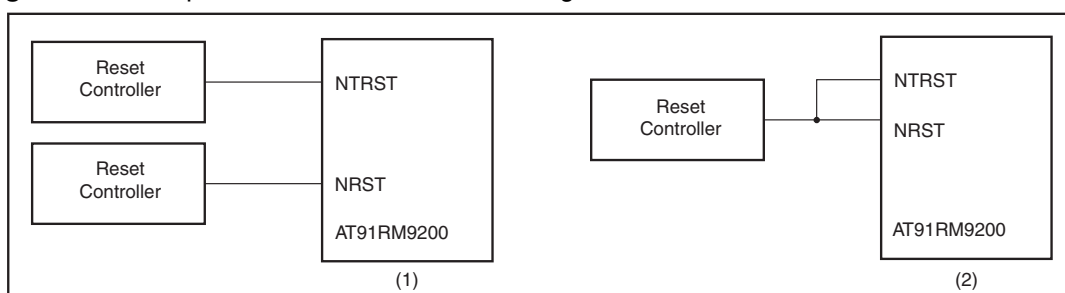

- Notes:
1. NRST and NTRST handling in Debug Mode during development.
 2. NRST and NTRST handling during production.

In order to benefit the most regarding the separation of NRST and NTRST during the Debug phase of development, the user must independently manage both signals as shown in example (1) of [Figure 15-3](#) above. However, once Debug is completed, both signals are easily managed together during production as shown in example (2) of [Figure 15-3](#) above.

15.1.3 Required Features for the Reset Controller

The following table presents the features required of a reset controller in order to obtain an optimal system with the AT91RM9200 processor.

Table 15-2. Reset Controller Functions Synthesis

Feature	Description
Power Supply Monitoring	Overlaps the transient state of the system during power-up/down and brownout.
Reset Active Timeout Period	Overlaps the start-up time of the boot-up oscillator by holding the reset signal during this delay.
Manual Reset Command	Asserts the reset signal from a logic command and holds the reset signal with a shorter delay than that of the "Reset Active Timeout Period".



16. Memory Controller(MC)

16.1 Overview

The Memory Controller (MC) manages the ASB bus and controls access by up to four masters. It features a bus arbiter and an address decoder that splits the 4G bytes of address space into areas to access the embedded SRAM and ROM, the embedded peripherals and the external memories through the External Bus Interface (EBI). It also features an abort status and a misalignment detector to assist in application debug.

The Memory Controller allows booting from the embedded ROM or from an external non-volatile memory connected to the Chip Select 0 of the EBI. The Remap command switches addressing of the ARM vectors (0x0 - 0x20) on the embedded SRAM.

Key Features of the AT91RM9200 Memory Controller are:

- Programmable Bus Arbiter Handling Four Masters
 - Internal Bus is Shared by ARM920T, PDC, USB Host Port and Ethernet MAC Masters
 - Each Master Can Be Assigned a Priority Between 0 and 7
- Address Decoder Provides Selection For
 - Eight External 256-Mbyte Memory Areas
 - Four Internal 1-Mbyte Memory Areas
 - One 256-Mbyte Embedded Peripheral Area
- Boot Mode Select Option
 - Non-volatile Boot Memory Can Be Internal or External
 - Selection is Made By BMS Pin Sampled at Reset
- Abort Status Registers
 - Source, Type and All Parameters of the Access Leading to an Abort are Saved
- Misalignment Detector
 - Alignment Checking of All Data Accesses
 - Abort Generation in Case of Misalignment
- Remap Command
 - Provides Remapping of an Internal SRAM in Place of the Boot NVM

16.2 Block Diagram

Figure 16-1. Memory Controller Block Diagram

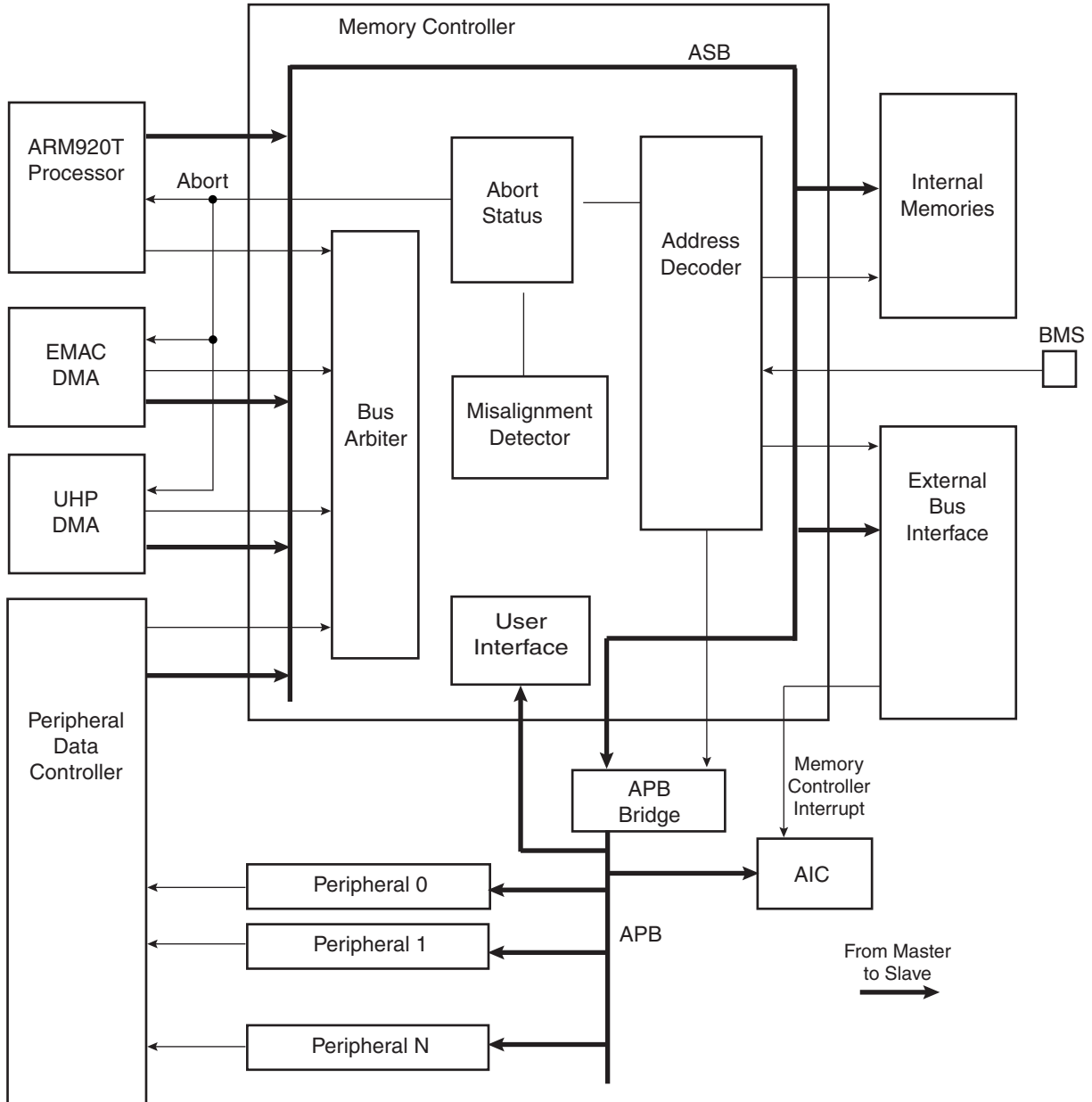

16.3 Functional Description

The Memory Controller (MC) handles the internal ASB bus and arbitrates the accesses of up to four masters.

It is made up of:

- A bus arbiter
- An address decoder
- An abort status
- A misalignment detector

The Memory Controller handles only little-endian mode accesses. All masters must work in little-endian mode only.

16.3.1 Bus Arbiter

The Memory Controller has a user-programmable bus arbiter. Each master can be assigned a priority between 0 and 7, where 7 is the highest level. The bus arbiter is programmed in the register MC_MPR (Master Priority Register).

The same priority level can be assigned to more than one master. If requests occur from two masters having the same priority level, the following default priority is used by the bus arbiter to determine the first to serve: Master 0, Master 1, Master 2, Master 3.

The masters are:

- the ARM920T as the Master 0
- the Peripheral DMA Controller as the Master 1
- the USB Host Port as the Master 2
- the Ethernet MAC as the Master 3

16.3.2 Address Decoder

The Memory Controller features an Address Decoder that first decodes the four highest bits of the 32-bit address bus and defines 11 separate areas:

- One 256-Mbyte address space for the internal memories
- Eight 256-Mbyte address spaces, each assigned to one of the eight chip select lines of the External Bus Interface
- One 256-Mbyte address space reserved for the embedded peripherals
- An undefined address space of 1536M bytes that returns an Abort if accessed

16.3.2.1 External Memory Areas

Figure 16-2 shows the assignment of the 256-Mbyte memory areas.

Figure 16-2. External Memory Areas

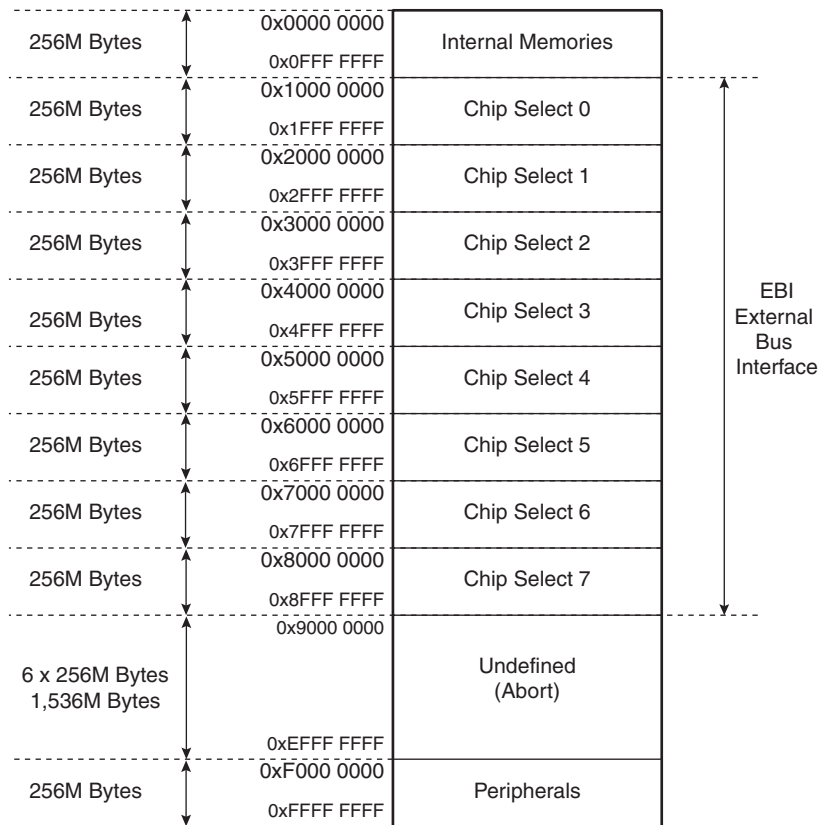

16.3.2.2 Internal Memory Mapping

Within the Internal Memory address space, the Address Decoder of the Memory Controller decodes eight more address bits to allocate 1-Mbyte address spaces for the embedded memories.

The allocated memories are accessed all along the 1-Mbyte address space and so are repeated n times within this address space, n equaling 1M byte divided by the size of the memory.

When the address of the access is undefined within the internal memory area, i.e. over the address 0x0040 0000, the Address Decoder returns an Abort to the master.

Figure 16-3. Internal Memory Mapping After Remap

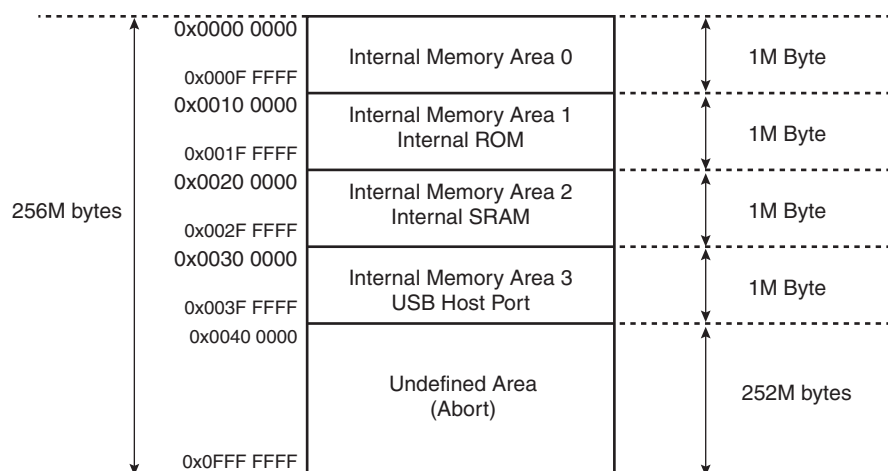

16.3.2.3 Internal Memory Area 0

Depending on the BMS pin state at reset and as a function of the remap command, the memory mapped at address 0x0 is different. Before execution of the remap command the on-chip ROM (BMS = 1) or the 16-bit non-volatile memory connected to external chip select zero (BMS = 0) is mapped into Internal Memory Area 0. After the remap command, the internal SRAM at address 0x0020 0000 is mapped into Internal Memory Area 0. The memory mapped into Internal Memory Area 0 is accessible in both its original location and at address 0x0.

The first 32 bytes of Internal Memory Area 0 contain the ARM processor exception vectors.

Table 16-1. Internal Memory Area Depending on BMS and the Remap Command

BMS State	Before Remap		After Remap
	1	0	X
Internal Memory Area 0	Internal ROM	External Memory Area 0	Internal SRAM

16.3.2.4 Boot Mode Select

The BMS pin state allows the device to boot out of an internal ROM or out of an external 16-bit memory connected on the signal NCS0. The input level on the BMS pin during the last 2 clock cycles before the reset selects the type of boot memory according to the following conditions:

- If high, the Internal ROM, which is generally mapped within the Internal Memory Area 1, is also accessible through the Internal Memory Area 0
- If low, the External Memory Area 0, which is generally accessible from address 0x10000000, is also accessible through the Internal Memory Area 0.

The BMS pin is multiplexed with an I/O line. After reset, this pin can be used as any standard PIO line.

16.3.3 Remap Command

After execution, the Remap Command causes the Internal SRAM to be accessed through the Internal Memory Area 0.

As the ARM vectors (Reset, Abort, Data Abort, Prefetch Abort, Undefined Instruction, Interrupt, and Fast Interrupt) are mapped from address 0x0 to address 0x20, the Remap Command allows the user to redefine dynamically these vectors under software control.

The Remap Command is accessible through the Memory Controller User Interface by writing the MC_RCR (Remap Control Register) RCB field to one.

The Remap Command can be cancelled by writing the MC_RCR RCB field to one, which acts as a toggling command. This allows easy debug of the user-defined boot sequence by offering a simple way to put the chip in the same configuration as just after a reset.

Table 16-1 on page 125 is provided to summarize the effect of these two key features on the nature of the memory mapped to the address 0x0.

16.3.4 Abort Status

There are two reasons for an abort to occur:

- an access to an undefined address
- an access to a misaligned address.

When an abort occurs, a signal is sent back to all the masters, regardless of which one has generated the access. However, only the master having generated the access leading to the abort takes this signal into account.

The abort signal generates directly an abort on the ARM9TDMI. Note that, from the processor perspective, an abort can also be generated by the Memory Management Unit of the ARM920T, but this is obviously not managed by the Memory Controller and not discussed in this section.

The Peripheral DMA Controller does not handle the abort input signal (and that's why the connection is not represented in Figure 16-1). The UHP reports an unrecoverable error in the HcInterruptStatus register and resets its operations. The EMAC reports the Abort to the user through the ABT bit in its Status Register, which might generate an interrupt.

To facilitate debug or for fault analysis by an operating system, the Memory Controller integrates an Abort Status register set.

The full 32-bit wide abort address is saved in the Abort Address Status Register (MC_AASR). Parameters of the access are saved in the Abort Status Register (MC_ASR) and include:

- the size of the request (ABTSZ field)
- the type of the access, whether it is a data read or write or a code fetch (ABTTYP field)
- whether the access is due to accessing an undefined address (UNDADD bit) or a misaligned address (MISADD bit)
- the source of the access leading to the last abort (MST0, MST1, MST2 and MST3 bits)
- whether or not an abort occurred for each master since the last read of the register (SVMST0, SVMST1, SVMST2 and SVMST3 bits) except if it is traced in the MST bits.

In case of Data Abort from the processor, the address of the data access is stored. This is probably the most useful, as finding which address has generated the abort would require disassembling the instruction and full knowledge of the processor context.

However, in case of prefetch abort, the address might have changed, as the prefetch abort is pipelined in the ARM processor. The ARM processor takes the prefetch abort into account only if the read instruction is actually executed and it is probable that several aborts have occurred during this time. So, in this case, it is preferable to use the content of the Abort Link register of the ARM processor.

16.3.5 Misalignment Detector

The Memory Controller features a Misalignment Detector that checks the consistency of the accesses.

For each access, regardless of the master, the size of access and the 0 and 1 bits of the address bus are checked. If the type of access is a word (32-bit) and the 0 and 1 bits are not 0, or if the type of the access is a half-word (16-bit) and the 0 bit is not 0, an abort is returned to the master and the access is cancelled. Note that the accesses of the ARM processor when it is fetching instructions are not checked.

The misalignments are generally due to software errors leading to wrong pointer handling. These errors are particularly difficult to detect in the debug phase.

As the requested address is saved in the Abort Status and the address of the instruction generating the misalignment is saved in the Abort Link Register of the processor, detection and correction of this kind of software error is simplified.

16.3.6 Memory Controller Interrupt

The Memory Controller itself does not generate any interrupt. However, as indicated in [Figure 16-1](#), the Memory Controller receives an interrupt signal from the External Bus Interface, which might be activated in case of Refresh Error detected by the SDRAM Controller. This interrupt signal just transits through the Memory Controller, which can neither enable/disable it nor return its activity.

This Memory Controller interrupt signal is ORed with the other System Peripheral interrupt lines (RTC, ST, DBGU, PMC) to provide the System Interrupt on Source 1 of the Advanced Interrupt Controller.

16.4 User Interface

Base Address: 0xFFFFF00

AT91RM9200 Memory Controller Memory Map

Offset	Register	Name	Access	Reset State
0x00	MC Remap Control Register	MC_RCR	Write-only	
0x04	MC Abort Status Register	MC_ASR	Read-only	0x0
0x08	MC Abort Address Status Register	MC_AASR	Read-only	0x0
0x0C	MC Master Priority Register	MC_MPR	Read/Write	0x3210
0x10 - 0x5C	Reserved			
0x60	EBI Configuration Registers	See “External Bus Interface (EBI)” on page 133		

16.4.1 MC Remap Control Register

Register Name: MC_RCR

Access Type: Write-only

Absolute Address: 0xFFFF FF00

31	30	29	28	27	26	25	24
–	–	–	–	–	–	–	–
23	22	21	20	19	18	17	16
–	–	–	–	–	–	–	–
15	14	13	12	11	10	9	8
–	–	–	–	–	–	–	–
7	6	5	4	3	2	1	0
–	–	–	–	–	–	–	RCB

- **RCB: Remap Command Bit**

0: No effect.

1: This Command Bit acts on a toggle basis: writing a 1 alternatively cancels and restores the remapping of the page zero memory devices.

16.4.2 MC Abort Status Register

Register Name: MC_ASR

Access Type: Read-only

Reset Value: 0x0

Absolute Address: 0xFFFF FF04

31	30	29	28	27	26	25	24
–	–	–	–	SVMST3	SVMST2	SVMST1	SVMST0
23	22	21	20	19	18	17	16
–	–	–	–	MST3	MST2	MST1	MST0
15	14	13	12	11	10	9	8
–	–	–	–	ABTTYP		ABTSZ	
7	6	5	4	3	2	1	0
–	–	–	–	–	–	MISADD	UNDADD

- **UNDADD: Undefined Address Abort Status**

0: The last abort was not due to the access of an undefined address in the address space.

1: The last abort was due to the access of an undefined address in the address space.

- **MISADD: Misaligned Address Abort Status**

0: The last aborted access was not due to an address misalignment.

1: The last aborted access was due to an address misalignment.

- **ABTSZ: Abort Size Status**

ABTSZ		Abort Size
0	0	Byte
0	1	Half-word
1	0	Word
1	1	Reserved

- **ABTTYP: Abort Type Status**

ABTTYP		Abort Type
0	0	Data Read
0	1	Data Write
1	0	Code Fetch
1	1	Reserved

- **MST0: ARM920T Abort Source**

0: The last aborted access was not due to the ARM920T.

1: The last aborted access was due to the ARM920T.

- **MST1: PDC Abort Source**

0: The last aborted access was not due to the PDC.

1: The last aborted access was due to the PDC.

- **MST2: UHP Abort Source**

0: The last aborted access was not due to the UHP.

1: The last aborted access was due to the UHP.

- **MST3: EMAC Abort Source**

0: The last aborted access was not due to the EMAC.

1: The last aborted access was due to the EMAC.

- **SVMST0: Saved ARM920T Abort Source**

0: No abort due to the ARM920T occurred since the last read of MC_ASR or it is notified in the bit MST0.

1: At least one abort due to the ARM920T occurred since the last read of MC_ASR.

- **SVMST1: Saved PDC Abort Source**

0: No abort due to the PDC occurred since the last read of MC_ASR or it is notified in the bit MST1.

1: At least one abort due to the PDC occurred since the last read of MC_ASR.

- **SVMST2: Saved UHP Abort Source**

0: No abort due to the UHP occurred since the last read of MC_ASR or it is notified in the bit MST2.

1: At least one abort due to the UHP occurred since the last read of MC_ASR.

- **SVMST3: Saved EMAC Abort Source**

0: No abort due to the EMAC occurred since the last read of MC_ASR or it is notified in the bit MST3.

1: At least one abort due to the EMAC occurred since the last read of MC_ASR.

16.4.3 MC Abort Address Status Register

Register Name: MC_AASR

Access Type: Read-only

Reset Value: 0x0

Absolute Address: 0xFFFF FF08

31	30	29	28	27	26	25	24
ABTADD							
23	22	21	20	19	18	17	16
ABTADD							
15	14	13	12	11	10	9	8
ABTADD							
7	6	5	4	3	2	1	0
ABTADD							

- **ABTADD: Abort Address**

This field contains the address of the last aborted access.

16.4.4 MC Master Priority Register

Register Name: MC_MPR

Access Type: Read/Write

Reset Value: 0x3210

Absolute Address: 0xFFFF FF0C

31	30	29	28	27	26	25	24
-	-	-	-	-	-	-	-
23	22	21	20	19	18	17	16
-	-	-	-	-	-	-	-
15	14	13	12	11	10	9	8
-	MSTP3			-	MSTP2		
7	6	5	4	3	2	1	0
-	MSTP1			-	MSTP0		

- **MSTP0: ARM920T Priority**

- **MSTP1: PDC Priority**

- **MSTP2: UHP Priority**

- **MSTP3: EMAC Priority**

000: Lowest priority

111: Highest priority

In the case of equal priorities, Master 0 has highest and Master 3 has lowest priority.

17. External Bus Interface (EBI)

17.1 Overview

The External Bus Interface (EBI) is designed to ensure the successful data transfer between several external devices and the embedded Memory Controller of an ARM-based device. The Static Memory, SDRAM and Burst Flash Controllers are all featured external Memory Controllers on the EBI. These external Memory Controllers are capable of handling several types of external memory and peripheral devices, such as SRAM, PROM, EPROM, EEPROM, Flash, SDRAM and Burst Flash.

The EBI also supports the CompactFlash and the NAND Flash/SmartMedia protocols via integrated circuitry that greatly reduces the requirements for external components. Furthermore, the EBI handles data transfers with up to eight external devices, each assigned to eight address spaces defined by the embedded Memory Controller. Data transfers are performed through a 16-bit or 32-bit data bus, an address bus of up to 26 bits, up to eight chip select lines (NCS[7:0]) and several control pins that are generally multiplexed between the different external Memory Controllers.

Features of the EBI are:

- Integrates Three External Memory Controllers:
 - Static Memory Controller
 - SDRAM Controller
 - Burst Flash Controller
- Additional Logic for NAND Flash/SmartMedia and CompactFlash Support
- Optimized External Bus:
 - 16- or 32-bit Data Bus⁽¹⁾
 - Up to 26-bit Address Bus, Up to 64 Mbytes Addressable
 - Up to 8 Chip Selects, Each Reserved for one of the Eight Memory Areas
 - Optimized Pin Multiplexing to Reduce Latencies on External Memories
- Configurable Chip Select Assignment:
 - Burst Flash Controller or Static Memory Controller on NCS0
 - SDRAM Controller or Static Memory Controller on NCS1
 - Static Memory Controller on NCS3, Optional NAND Flash/SmartMedia Support
 - Static Memory Controller on NCS4 - NCS6, Optional NAND Flash/SmartMedia and CompactFlash Support
 - Static Memory Controller on NCS7

Note: 1. The 32-bit Data Bus is for SDRAM only.

17.2 Block Diagram

Figure 17-1 below shows the organization of the External Bus Interface.

Figure 17-1. Organization of the External Bus Interface

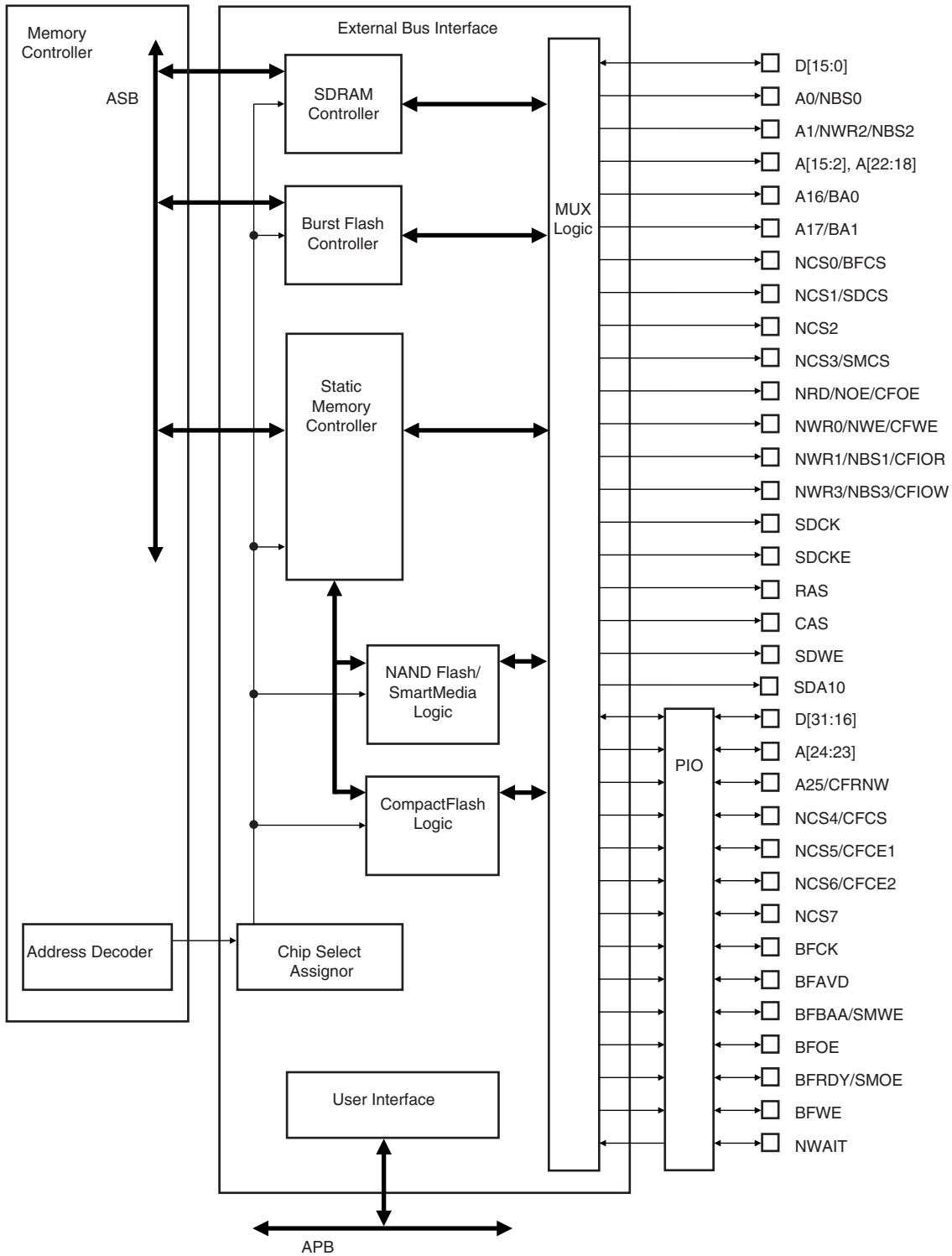

17.3 I/O Lines Description

Table 17-1. I/O Lines Description

Name	Function	Type	Active Level
EBI			
D[31:0]	Data Bus	I/O	
A[25:0]	Address Bus	Output	
SMC			
NCS[7:0]	Chip Select Lines	Output	Low
NWR[1:0]	Write Signals	Output	Low
NOE	Output Enable	Output	Low
NRD	Read Signal	Output	Low
NBS1	NUB: Upper Byte Select	Output	Low
NBS0	NLB: Lower Byte Select	Output	Low
NWE	Write Enable	Output	Low
NWAIT	Wait Signal	Input	Low
EBI for CompactFlash Support			
CFCE[2:1]	CompactFlash Chip Enable	Output	Low
CFOE	CompactFlash Output Enable	Output	Low
CFWE	CompactFlash Write Enable	Output	Low
CFIOR	CompactFlash I/O Read Signal	Output	Low
CFIOW	CompactFlash I/O Write Signal	Output	Low
CFRNW	CompactFlash Read Not Write Signal	Output	
CFCS	CompactFlash Chip Select Line	Output	Low
EBI for NAND Flash/SmartMedia Support			
SMCS	NAND Flash/Smart Media Chip Select Line	Output	Low
SMOE	NAND Flash/SmartMedia Output Enable	Output	Low
SMWE	NAND Flash/SmartMedia Write Enable	Output	Low
SDRAM Controller			
SDCK	SDRAM Clock	Output	
SDCKE	SDRAM Clock Enable	Output	High
SDCS	SDRAM Controller Chip Select Line	Output	Low
BA[1:0]	Bank Select	Output	
SDWE	SDRAM Write Enable	Output	Low
RAS - CAS	Row and Column Signal	Output	Low
NWR[3:0]	Write Signals	Output	Low
NBS[3:0]	Byte Mask Signals	Output	Low
SDA10	SDRAM Address 10 Line	Output	

Table 17-1. I/O Lines Description (Continued)

Name	Function	Type	Active Level
Burst Flash Controller			
BFCK	Burst Flash Clock	Output	
BFCS	Burst Flash Chip Select Line	Output	Low
BFAVD	Burst Flash Address Valid Signal	Output	Low
BFBA	Burst Flash Address Advance Signal	Output	Low
BFOE	Burst Flash Output Enable	Output	Low
BFRDY	Burst Flash Ready Signal	Input	High
BFWE	Burst Flash Write Enable	Output	Low

The connection of some signals through the MUX logic is not direct and depends on the Memory Controller in use at the moment.

[Table 17-2](#) below details the connections between the three Memory Controllers and the EBI pins.

Table 17-2. EBI Pins and Memory Controllers I/O Line Connections

EBI Pins	SDRAMC I/O Lines	BFC I/O Lines	SMC I/O Lines
NWR1/NBS1/CFIOR	NBS1	Not Supported	NWR1/NUB
A0/NBS0	Not Supported	Not Supported	A0/NLB
A1	Not Supported	A0	A1
A[11:2]	A[9:0]	A[10:1]	A[11:2]
SDA10	A10	Not Supported	Not Supported
A12	Not Supported	A11	A12
A[14:13]	A[12:11]	A[13:12]	A[14:13]
A[25:15]	Not Supported	A[24:14]	A[25:15]
D[31:16]	D[31:16]	Not Supported	Not Supported
D[15:0]	D[15:0]	D[15:0]	D[15:0]

17.4 Application Example

17.4.1 Hardware Interface

Table 17-3 below details the connections to be applied between the EBI pins and the external devices for each Memory Controller.

Table 17-3. EBI Pins and External Device Connections

Pin	Pins of the Interfaced Device						
	8-bit Static Device	2 x 8-bit Static Devices	16-bit Static Device	Burst Flash Device	SDRAM	CompactFlash	NAND Flash/ SmartMedia
Controller	SMC			BFC	SDRAMC	SMC	
D0 - D7	D0 - D7	D0 - D7	D0 - D7	D0 - D7	D0 - D7	D0 - D7	AD0 - AD7
D8 - D15	–	D8 - D15	D8 - D15	D8 - D15	D8 - D15	D8 - 15	–
D16 - D31	–	–	–	–	D16 - D31	–	–
A0/NBS0	A0	–	NLB	–	DQM0	A0	–
A1/NWR2/NBS2	A1	A0	A0	A0	DQM2	A1	–
A2 - A9	A2 - A9	A1 - A8	A1 - A8	A1 - A8	A0 - A7	A2 - A9	–
A10	A10	A9	A9	A9	A8	A10	–
A11	A11	A10	A10	A10	A9	–	–
SDA10	–	–	–	–	A10	–	–
A12	A12	A11	A11	A11	–	–	–
A13 - A14	A13 - A14	A12 - A13	A12 - A13	A12 - A13	A11 - A12	–	–
A15	A15	A14	A14	A14	–	–	–
A16/BA0	A16	A15	A15	A15	BA0	–	–
A17/BA1	A17	A16	A16	A16	BA1	–	–
A18 - A20	A18 - A20	A17 - A19	A17 - A19	A17 - A19	–	–	–
A21	A21	A20	A20	A20	–	–	CLE
A22	A22	A21	A21	A21	–	REG ⁽³⁾	ALE
A23 - A24	A23 - A24	A22 - A23	A22 - A23	A22 - A23	–	–	–
A25	A25	A24	A24	A24	–	CFRNW ⁽¹⁾	–
NCS0/BFCS	CS	CS	CS	CS	–	–	–
NCS1/SDCS	CS	CS	CS	–	CS	–	–
NCS2	CS	CS	CS	–	–	–	–
NCS3/SMCS	CS	CS	C S	–	–	–	–
NCS4/CFCS	CS	CS	CS	–	–	CFCS ⁽¹⁾	–
NCS5/CFCE1	CS	CS	CS	–	–	CE1	–
NCS6/CFCE2	CS	CS	CS	–	–	CE2	–
NRD/NOE/CFOE	OE	OE	OE	–	–	OE	–
NWR0/NWE/CFWE	WE	WE ⁽⁵⁾	WE	–	–	WE	–

Table 17-3. EBI Pins and External Device Connections (Continued)

Pin	Pins of the Interfaced Device						
	8-bit Static Device	2 x 8-bit Static Devices	16-bit Static Device	Burst Flash Device	SDRAM	CompactFlash	NAND Flash/ SmartMedia
Controller	SMC			BFC	SDRAMC	SMC	
NWR1/NBS1/CFIOR	–	WE ⁽⁵⁾	NUB	–	DQM1	IOR	–
NWR3/NBS3/CFIOW	–	–	–	–	DQM3	IOW	–
BFCK	–	–	–	CK	–	–	–
BFAVD	–	–	–	AVD	–	–	–
BFBA/SMWE	–	–	–	BAA	–	–	WE
BFOE	–	–	–	OE	–	–	–
BFRDY/SMOE	–	–	–	RDY	–	–	OE
BFWE	–	–	–	WE	–	–	–
SDCK	–	–	–	–	CLK	–	–
SDCKE	–	–	–	–	CKE	–	–
RAS	–	–	–	–	RAS	–	–
CAS	–	–	–	–	CAS	–	–
SDWE	–	–	–	–	WE	–	–
NWAIT	–	–	–	–	–	WAIT	–
Pxx ⁽²⁾	–	–	–	–	–	CD1 or CD2	–
Pxx ⁽²⁾	–	–	–	–	–	–	CE
Pxx ⁽²⁾	–	–	–	–	–	–	RDY

- Notes:
1. Not directly connected to the CompactFlash slot. Permits the control of the bidirectional buffer between the EBI data bus and the CompactFlash slot.
 2. Any PIO line.
 3. The REG signal of the CompactFlash can be driven by any of the following address bits: A24, A22 to A11. For details, see [Section 17.6.6 “CompactFlash Support” on page 141](#).
 4. NWR1 enables upper byte writes. NWR0 enables lower byte writes.

17.4.2 Connection Examples

Figure 17-2 below shows an example of connections between the EBI and external devices.

Figure 17-2. EBI Connections to Memory Devices

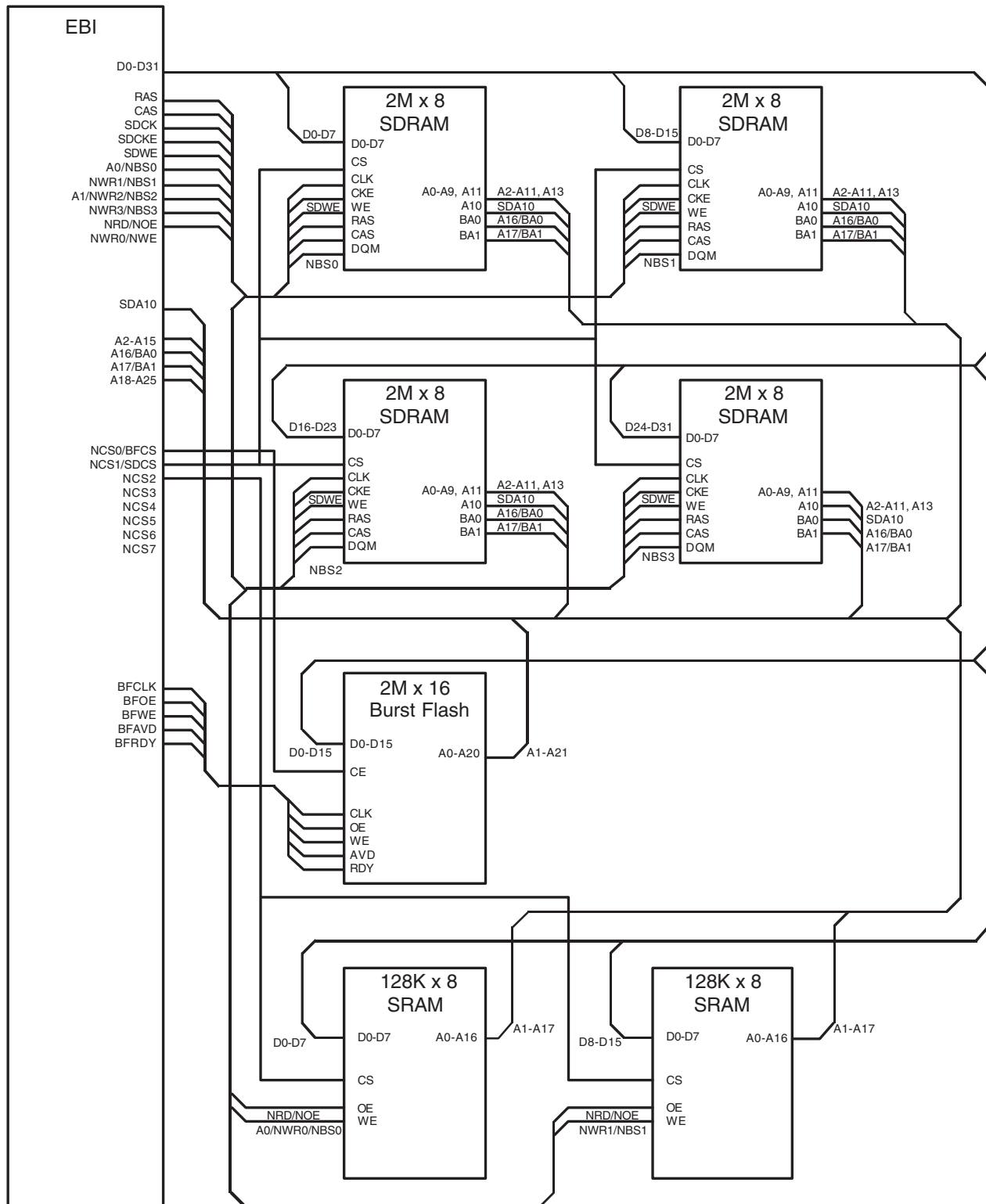

17.5 Product Dependencies

17.5.1 I/O Lines

The pins used for interfacing the External Bus Interface may be multiplexed with the PIO lines. The programmer must first program the PIO controller to assign the External Bus Interface pins to their peripheral function. If I/O lines of the External Bus Interface are not used by the application, they can be used for other purposes by the PIO Controller.

17.6 Functional Description

The EBI transfers data between the internal ASB Bus (handled by the Memory Controller) and the external memories or peripheral devices. It controls the waveforms and the parameters of the external address, data and control busses and is composed of the following elements:

- The Static Memory Controller (SMC)
- The SDRAM Controller (SDRAMC)
- The Burst Flash Controller (BFC)
- A chip select assignment feature that assigns an ASB address space to the external devices.
- A multiplex controller circuit that shares the pins between the different Memory Controllers.
- Programmable CompactFlash support logic
- Programmable NAND Flash /SmartMedia and support logic

17.6.1 Bus Multiplexing

The EBI offers a complete set of control signals that share the 32-bit data lines, the address lines of up to 26 bits and the control signals through a multiplex logic operating in function of the memory area requests.

Multiplexing is specifically organized in order to guarantee the maintenance of the address and output control lines at a stable state while no external access is being performed. Multiplexing is also designed to respect the data float times defined in the Memory Controllers. Furthermore, refresh cycles of the SDRAM are executed independently by the SDRAM Controller without delaying the other external Memory Controller accesses. Lastly, it prevents burst accesses on the same page of a burst Flash from being interrupted which avoids the need to restart a high-latency first access.

17.6.2 Pull-up Control

The EBI permits enabling of on-chip pull-up resistors on the data bus lines not multiplexed with the PIO Controller lines. The pull-up resistors are enabled after reset. Setting the DBPUC bit disables the pull-up resistors on the D0 to D15 lines. Enabling the pull-up resistor on the D16 - D31 lines can be performed by programming the appropriate PIO controller.

17.6.3 Static Memory Controller

For information on the Static Memory Controller, refer to the SMC [Section 18.1 “Description” on page 155](#).

17.6.4 SDRAM Controller

For information on the SDRAM Controller, refer to the SDRAMC description on [Section 19.1 “Overview” on page 193](#).

17.6.5 Burst Flash Controller

For information on the Burst Flash Controller, refer to the BFC [Section 20.1 “Overview” on page 215](#).

17.6.6 CompactFlash Support

The External Bus Interface integrates circuitry that interfaces to CompactFlash devices.

The CompactFlash logic is driven by the Static Memory Controller (SMC) on the NCS4 address space. Programming the CS4A field of the Chip Select Assignment Register ([See Section 17.8.1 “EBI Chip Select Assignment Register” on page 152](#).) to the appropriate value enables this logic. Access to an external CompactFlash device is then made by accessing the address space reserved to NCS4 (i.e., between 0x5000 0000 and 0x5FFF FFFF).

When multiplexed with CFCE1 and CFCE2 signals, the NCS5 and NCS6 signals become unavailable. Performing an access within the address space reserved to NCS5 and NCS6 (i.e., between 0x6000 0000 and 0x7FFF FFFF) may lead to an unpredictable outcome.

The True IDE Mode is not supported and in I/O Mode, the signal `_IOIS16` is not managed.

17.6.6.1 I/O Mode, Common Memory Mode and Attribute Memory Mode

Within the NCS4 address space, the current transfer address is used to distinguish I/O mode, common memory mode and attribute memory mode. More precisely, the A23 bit of the transfer address is used to select I/O Mode. Any EBI address bit not required by the CompactFlash device (i.e., bit A24 or bits A22 to A11) can be used to separate common memory mode and attribute memory mode. Using the A22 bit, for example, leads to the address map in [Figure 17-3](#) below. In this figure, “i” stands for any hexadecimal digit.

Figure 17-3. Address Map Example

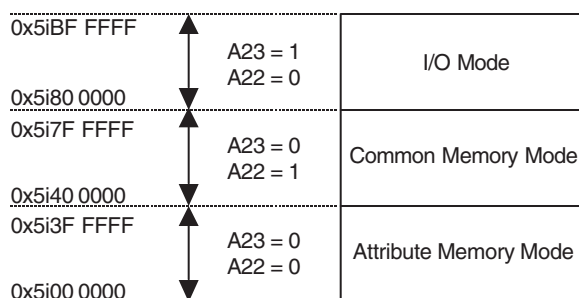

Note: In the above example, the A22 pin of the EBI can be used to drive the REG signal of the CompactFlash Device.

17.6.6.2 Read/Write Signals

In I/O mode, the CompactFlash logic drives the read and write command signals of the SMC on CFIOR and CFIOW signals, while the CFOE and CFWE signals are deactivated. Likewise, in common memory mode and attribute memory mode, the SMC signals are driven on the CFOE and CFWE signals, while the CFIOR and CFIOW are deactivated. [Figure 17-4 on page 142](#) demonstrates a schematic representation of this logic.

Attribute memory mode, common memory mode and I/O mode are supported by setting the address setup and hold time on the NCS4 chip select to the appropriate values. For details on these signal waveforms, please refer to: [Section 18.6.5 “Setup and Hold Cycles” on page 168](#) of the Static Memory Controller documentation.

Figure 17-4. CompactFlash Read/Write Control Signals

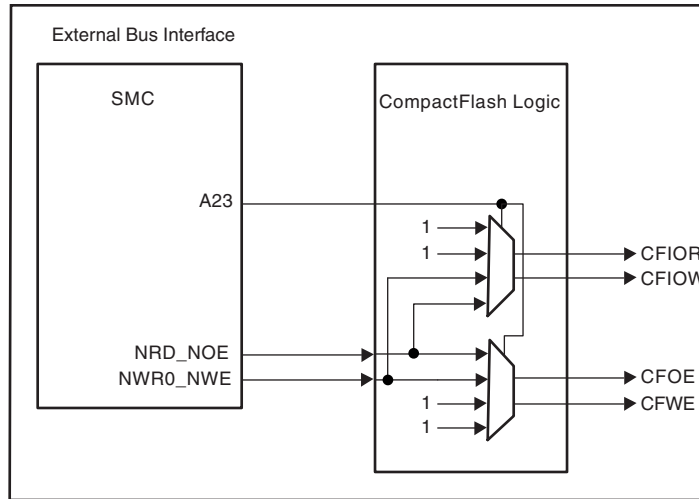

17.6.6.3 Access Type

The CFCE1 and CFCE2 signals enable upper- and lower-byte access on the data bus of the CompactFlash device in accordance with [Table 17-4](#) below. The odd byte access on the D[7:0] bus is only possible when the SMC is configured to drive 8-bit memory devices on the NCS4 pin. The Chip Select Register (DBW field in [Section 18.7.1 “SMC Chip Select Registers”](#) on page 190) of the NCS4 address space must be set as shown in [Table 17-4](#) to enable the required access type. The CFCE1 and CFCE2 waveforms are identical to the NCS4 waveform. For details on these waveforms and timings, refer to the Static Memory Controller [Section 18.1 “Description”](#) on page 155.

Table 17-4. Upper- and Lower-byte Access

Access	CFCE2	CFCE1	A0	D[15:8]	D[7:0]	SMC_CSR4 (DBW)
Byte R/W Access	1	0	0	Don't Care/High Z	Even Byte	8-bit or 16-bit
	1	0	1	Don't Care/High Z	Odd Byte	8-bit
Odd Byte R/W Access	0	1	X	Odd Byte	Don't Care/High Z	16-bit
Half-word R/W Access	0	0	X	Odd Byte	Even Byte	16-bit

17.6.6.4 Multiplexing of CompactFlash Signals on EBI Pins

[Table 17-5](#) below and [Table 17-6](#) on page 143 illustrate the multiplexing of the CompactFlash logic signals with other EBI signals on the EBI pins. The EBI pins in [Table 17-5](#) are strictly dedicated to the CompactFlash interface as soon as the CS4A field of the Chip Select Assignment Register is set (See [Section 17.8.1 “EBI Chip Select Assignment Register”](#) on page 152.) These pins must not be used to drive any other memory devices.

The EBI pins in [Table 17-6 on page 143](#) remain shared between all memory areas when the CompactFlash interface is enabled (CS4A = 1).

Table 17-5. Dedicated CompactFlash Interface Multiplexing

Pins	CS4A = 1	CS4A = 0
	CompactFlash Signals	EBI Signals
NCS4/CFCS	CFCS	NCS4
NCS5/CFCE1	CFCE1	NCS5
NCS6/CFCE2	CFCE2	NCS6

Table 17-6. Shared CompactFlash Interface Multiplexing

Pins	Access to CompactFlash Device	Access to Other EBI Devices
	CompactFlash Signals	EBI Signals
NOE/NRD/CFOE	CFOE	NRD/NOE
NWR0/NWE/CFWE	CFWE	NWR0/NWE
NWR1/NBS1/CFIOR	CFIOR	NWR1/NBS1
NWR3/NBS3/CFIOW	CFIOW	NWR3/NBS3
A25/CFRNW	CFRNW	A25

17.6.6.5 CompactFlash Application Example

[Figure 17-5](#) below illustrates an example of a CompactFlash application. CFCS and CFRNW signals are not directly connected to the CompactFlash slot, but do control the direction and the output enable of the buffers between the EBI and the CompactFlash Device. The timing of the CFCS signal is identical to the NCS4 signal. Moreover, the CFRNW signal remains valid throughout the transfer, as does the address bus. The CompactFlash _WAIT signal is connected to the NWAIT input of the Static Memory Controller. For details on these waveforms and timings, refer to the Static Memory Controller [Section 18.1 “Description” on page 155](#).

Figure 17-5. CompactFlash Application Example

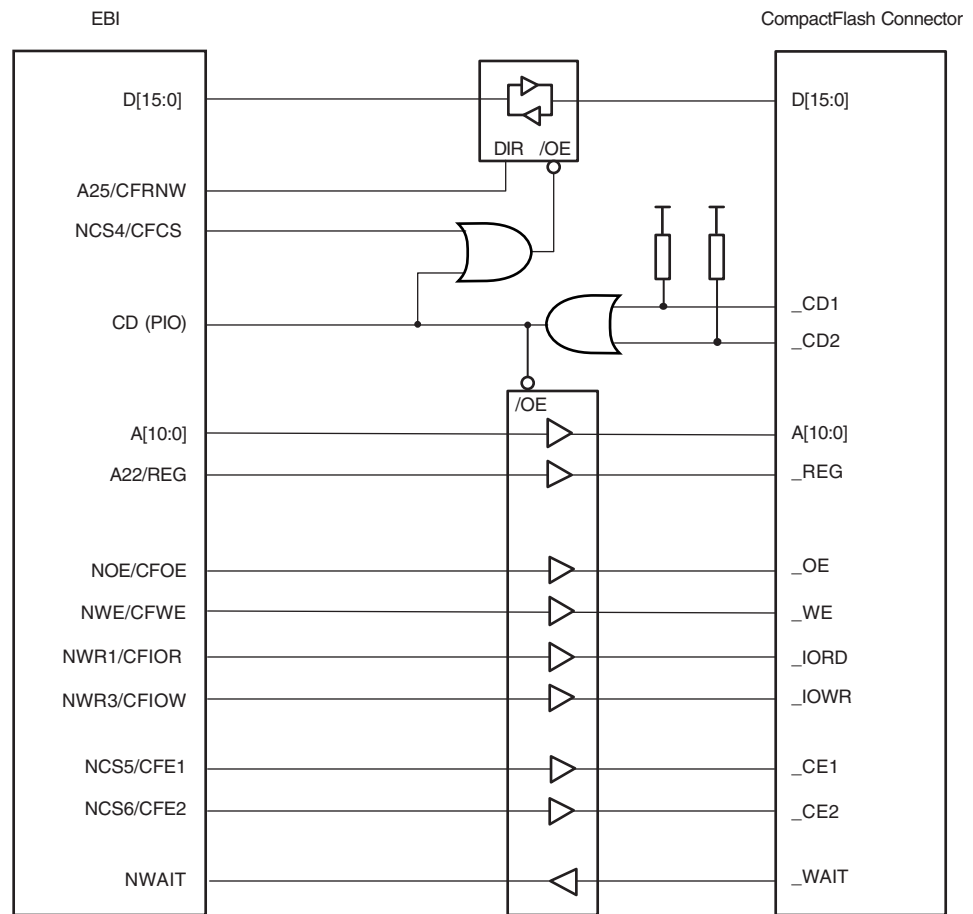

17.6.7 NAND Flash/ SmartMedia Support

The EBI integrates circuitry that interfaces to NAND Flash/SmartMedia devices.

The NAND Flash/SmartMedia logic is driven by the Static Memory Controller on the NCS3 address space. Programming the CS3A field in the Chip Select Assignment Register to the appropriate value enables the NAND Flash/SmartMedia logic (See Section 17.8.1 "EBI Chip Select Assignment Register" on page 152.) Access to an external NAND Flash/SmartMedia device is then made by accessing the address space reserved to NCS3 (i.e., between 0x4000 0000 and 0x4FFF FFFF).

The NAND Flash/SmartMedia Logic drives the read and write command signals of the SMC on the SMOE and SMWE signals when the NCS3 signal is active. SMOE and SMWE are invalidated as soon as the transfer address fails to lie in the NCS3 address space. For details on these waveforms, refer to the Static Memory Controller Section 18.1 "Description" on page 155.

The SMWE and SMOE signals are multiplexed with BFRDY and BFBA signals of the Burst Flash Controller. This multiplexing is controlled in the MUX logic part of the EBI by the CS3A field of the Chip Select Assignment Register (See Section 17.8.1 "EBI Chip Select Assignment Register" on page 152.) This logic also controls the direction of the BFRDY/SMOE pad.

Figure 17-6. NAND Flash/SmartMedia Signal Multiplexing on EBI Pins

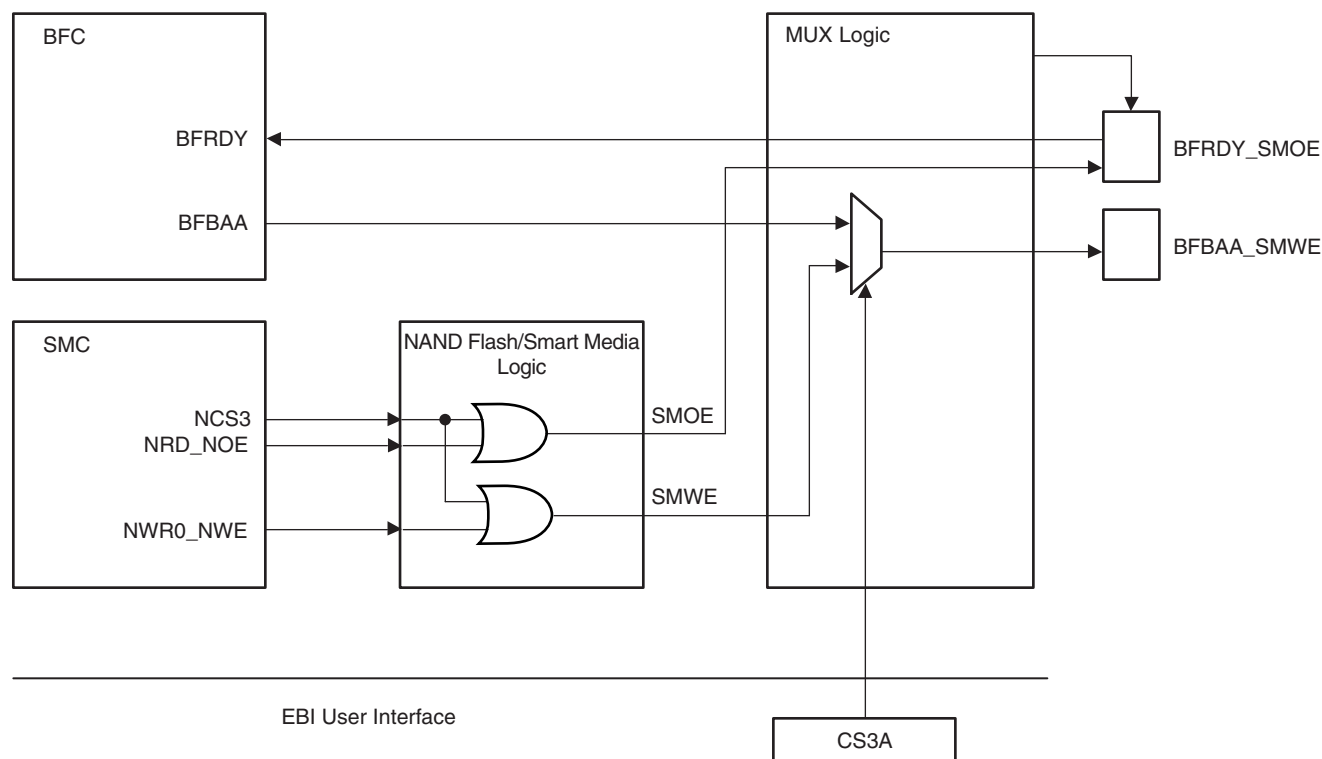

The address latch enable and command latch enable signals on the NAND Flash/SmartMedia device are driven by address bits A22 and A21 of the EBI address bus. The user should note that any bit on the EBI address bus can also be used for this purpose. The command, address or data words on the data bus of the NAND Flash/SmartMedia device are distinguished by using their address within the NCS3 address space. The chip enable (CE) signal of the device and the ready/busy (R/B) signals are connected to PIO lines. The CE signal then remains asserted even when NCS3 is not selected, preventing the device from returning to standby mode. Some functional limitation with the supported burst Flash device will occur when the NAND Flash/SmartMedia device is activated due to the fact that the SMOE and SMWE signals are multiplexed with BFRDY and BFBA signals respectively.

Figure 17-7. NAND Flash/SmartMedia Application Example

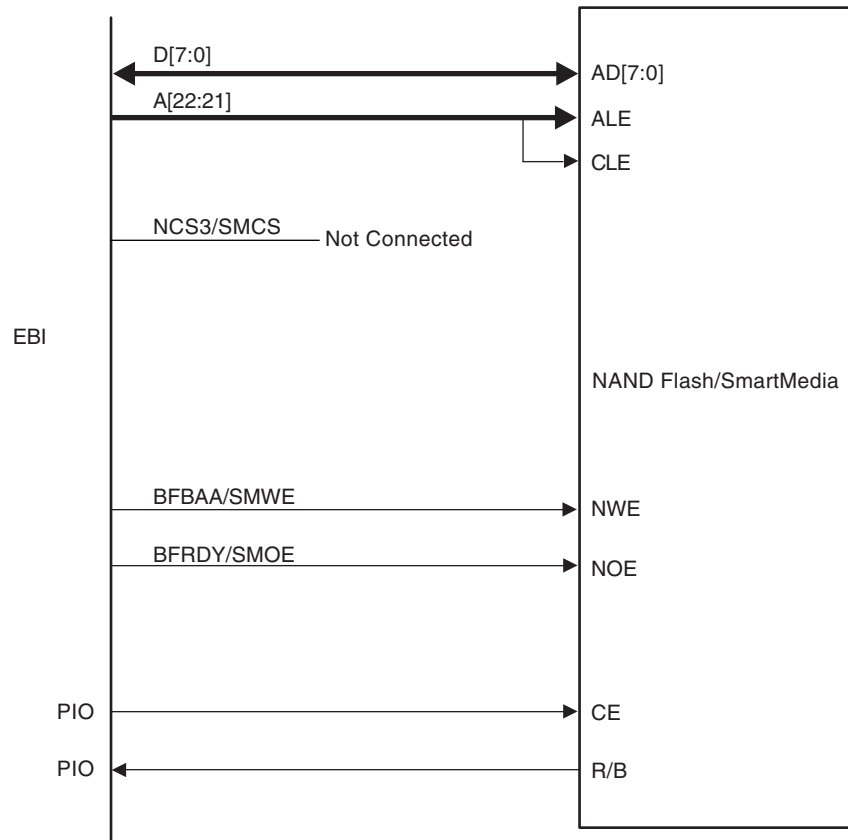

17.7 Implementation Examples

17.7.1 16-bit SDRAM

17.7.1.1 Hardware Configuration

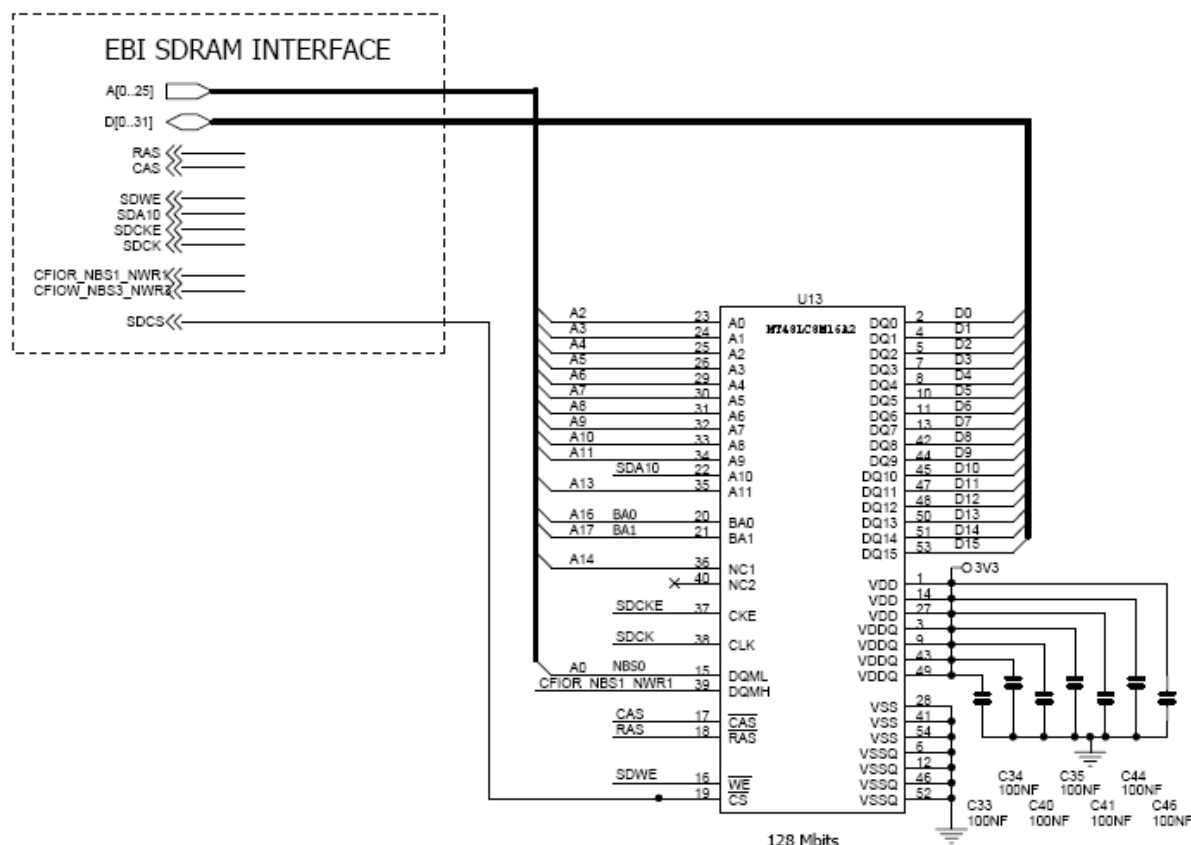

17.7.1.2 Software Configuration

The following configuration has to be performed:

- Assign the EBI CS1 to the SDRAM controller by setting the bit EBI_CS1A in the EBI Chip Select Assignment Register located in the bus matrix memory space
- Initialize the SDRAM Controller accordingly to SDRAM device and system bus frequency.

The Data Bus Width is to be programmed to 16 bits.

The SDRAM initialization sequence is described in the “SDRAM Device Initialization” part of the SDRAM controller.

17.7.2 32-bit SDRAM

17.7.2.1 Hardware Configuration

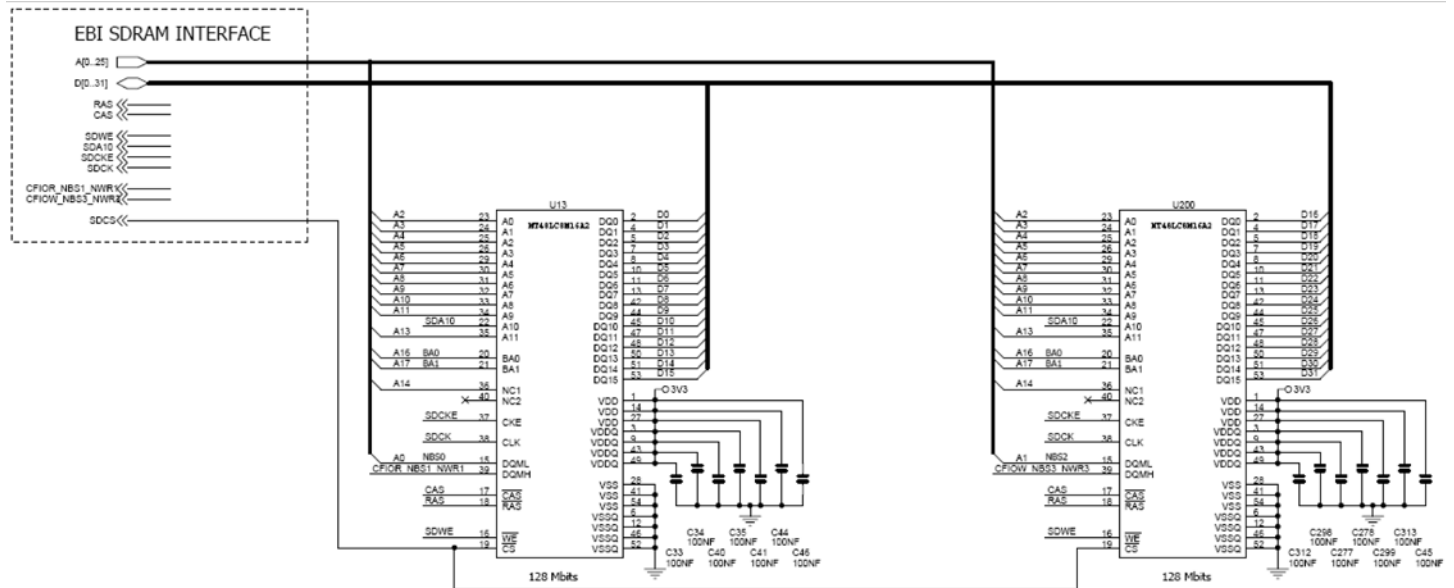

17.7.2.2 Software Configuration

The following configuration has to be performed:

- Assign the EBI CS1 to the SDRAM controller by setting the bit EBI_CS1A in the EBI Chip Select Assignment Register located in the bus matrix memory space
- Initialize the SDRAM Controller accordingly to SDRAM device and system bus frequency.

The Data Bus Width is to be programmed to 32 bits. The data lines D[16..31] are multiplexed with PIO lines and thus the dedicated PIOs must be programmed in peripheral mode in the PIO controller.

The SDRAM initialization sequence is described in the “SDRAM Device Initialization” part of the SDRAM controller.

17.7.3 NOR Flash on NCS0

17.7.3.1 Hardware Configuration

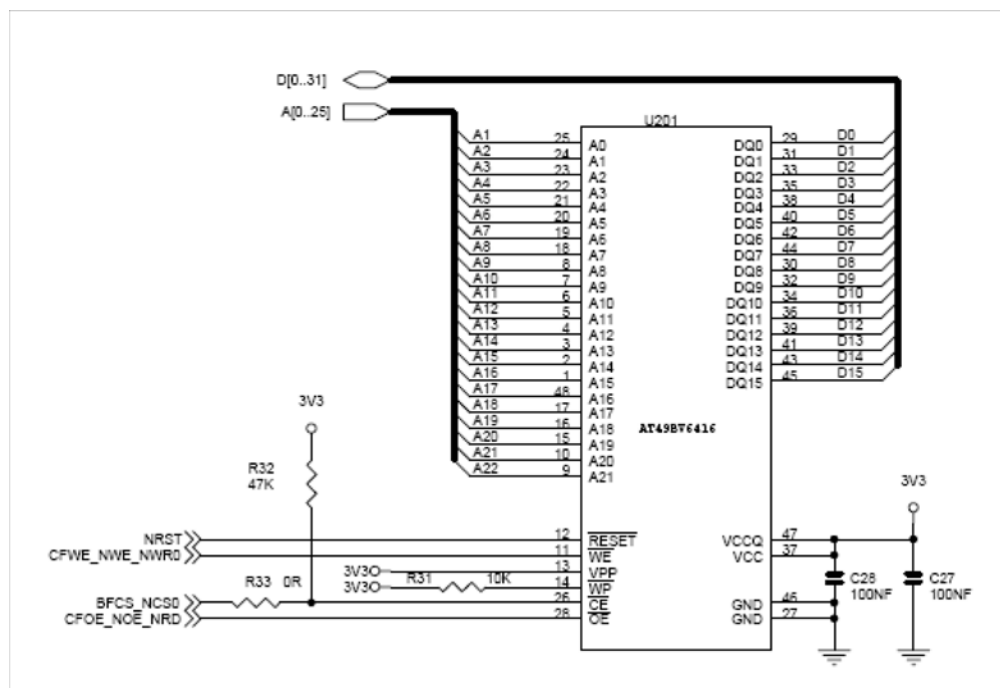

17.7.3.2 Software Configuration

The default configuration for the Static Memory Controller, byte select mode, 16-bit data bus, Read/Write controlled by Chip Select, allows boot on a 16-bit non-volatile memory at slow clock.

For other configurations, configure Static Memory Controller CS0 Setup, Pulse, Cycle and Mode accordingly to Flash timings and system bus frequency.

17.7.4 Compact Flash

17.7.4.1 Hardware Configuration

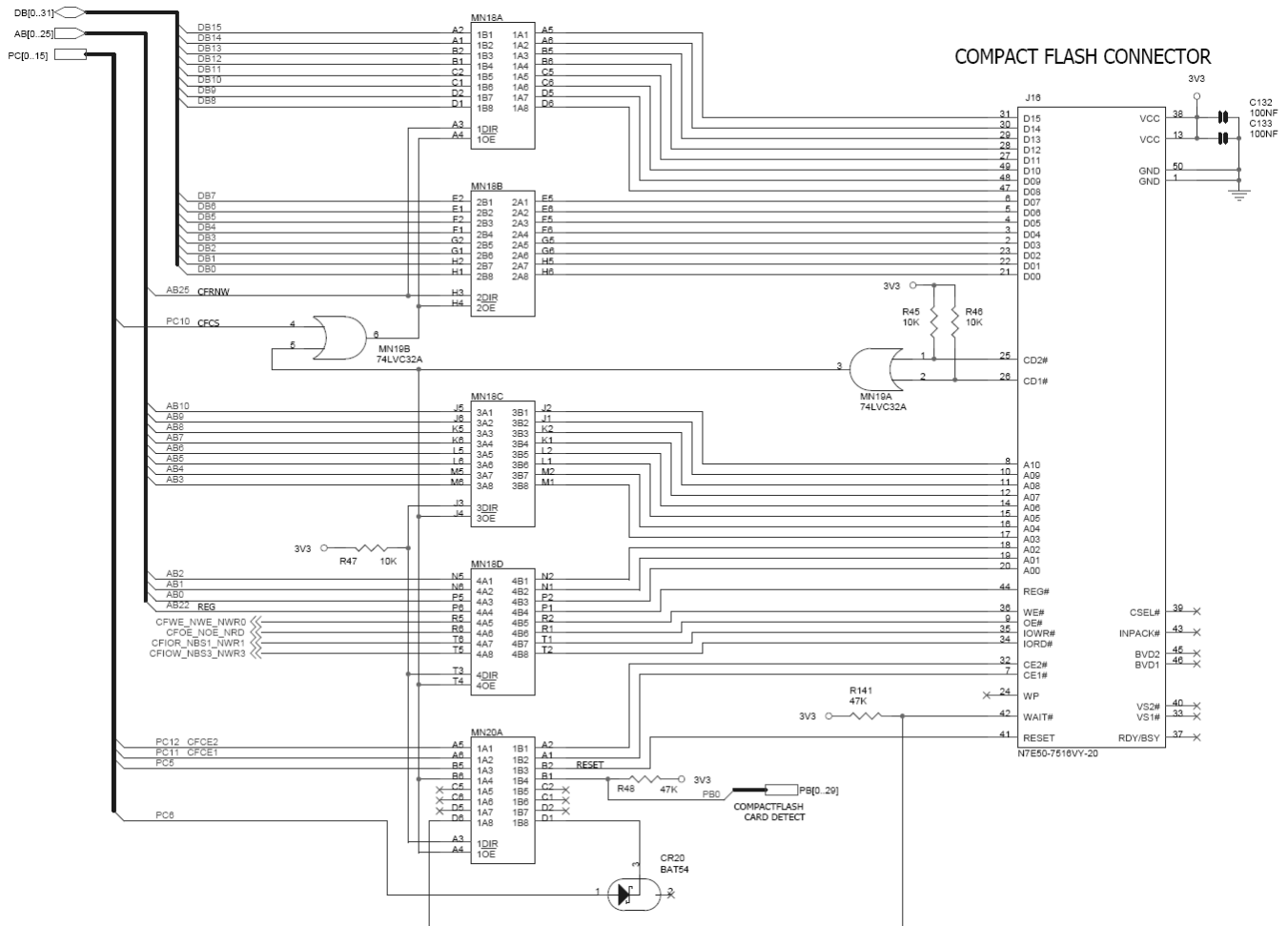

17.7.4.2 Software Configuration

The following configuration has to be performed:

- Assign the EBI CS4 to the CompactFlash slot by setting the bit EBI_CS4A in the EBI Chip Select Assignment Register located in the Bus Matrix memory space.
- The address line A23 is to select I/O (A23=1) or Memory mode (A23=0) and the address line A22 for REG function.
- A23, CFRNW, CFCS0, CFCE1 and CFCE2 signals are multiplexed with PIO lines and thus the dedicated PIOs must be programmed in peripheral mode in the PIO controller
- Configure a PIO line as an output for CFRST and two others as an input for CFIRQ and CARD DETECT functions respectively.
- Configure SMC CS4 Setup, Pulse, Cycle and Mode accordingly to Compact Flash timings and system bus frequency.

17.8 External Bus Interface (EBI) User Interface

AT91RM9200 EBI User Interface Base Address: 0xFFFF FF60

Table 17-7. External Bus Interface Memory Map

Offset	Register	Name	Access	Reset State
0x00	Chip Select Assignment Register	EBI_CSA	Read/Write	0x0
0x04	Configuration Register	EBI_CFGR	Read/Write	0x0
0x08	Reserved		–	
0x0C	Reserved		–	
0x10 - 0x2C	SMC User Interface	(See Section 18.7 "Static Memory Controller (SMC) User Interface" on page 189.)		
0x30 - 0x5C	SDRAMC User Interface	(See Section 19.7 "SDRAM Controller (SDRAMC) User Interface" on page 205.)		
0x60	BFC User Interface	(See Section 20.7 "Burst Flash Controller (BFC) User Interface" on page 227.)		
0x64 - 0x9C	Reserved			

17.8.1 EBI Chip Select Assignment Register

Register Name: EBI_CSA
Access Type: Read/Write
Reset Value: 0x0
Offset: 0x0
Absolute Address: 0xFFFF FF60

31	30	29	28	27	26	25	24
–	–	–	–	–	–	–	–
23	22	21	20	19	18	17	16
–	–	–	–	–	–	–	–
15	14	13	12	11	10	9	8
–	–	–	–	–	–	–	–
7	6	5	4	3	2	1	0
–	–	–	CS4A	CS3A	–	CS1A	CS0A

- **CS0A: Chip Select 0 Assignment**

0 = Chip Select 0 is assigned to the Static Memory Controller.

1 = Chip Select 0 is assigned to the Burst Flash Controller.

- **CS1A: Chip Select 1 Assignment**

0 = Chip Select 1 is assigned to the Static Memory Controller.

1 = Chip Select 1 is assigned to the SDRAM Controller.

- **CS3A: Chip Select 3 Assignment**

0 = Chip Select 3 is only assigned to the Static Memory Controller and NCS3 behaves as defined by the SMC.

1 = Chip Select 3 is assigned to the Static Memory Controller and the NAND Flash/SmartMedia Logic is activated.

- **CS4A: Chip Select 4 Assignment**

0 = Chip Select 4 is assigned to the Static Memory Controller and NCS4, NCS5 and NCS6 behave as defined by the SMC.

1 = Chip Select 4 is assigned to the Static Memory Controller and the CompactFlash Logic is activated.

Accessing the address space reserved to NCS5 and NCS6 may lead to an unpredictable outcome.

17.8.2 EBI Configuration Register

Register Name: EBI_CFGR

Access Type: Read/Write

Reset Value: 0x0

Offset: 0x04

Absolute Address: 0xFFFF FF64

31	30	29	28	27	26	25	24
–	–	–	–	–	–	–	–
23	22	21	20	19	18	17	16
–	–	–	–	–	–	–	–
15	14	13	12	11	10	9	8
–	–	–	–	–	–	–	–
7	6	5	4	3	2	1	0
–	–	–	–	–	–		DBPUC

- **DBPUC: Data Bus Pull-Up Configuration**

0 = [D15:0] Data Bus bits are internally pulled-up to the VDDIOM power supply.

1 = [D15:0] Data Bus bits are not internally pulled-up.

18. Static Memory Controller (SMC)

18.1 Description

The Static Memory Controller (SMC) generates the signals that control the access to external static memory or peripheral devices. The SMC is fully programmable. It has eight chip selects and a 23-bit address bus. The 16-bit data bus can be configured to interface with 8- or 16-bit external devices. Separate read and write control signals allow for direct memory and peripheral interfacing. The SMC supports different access protocols allowing single clock cycle memory accesses. It also provides an external wait request capability.

18.2 Block Diagram

Figure 18-1. Static Memory Controller Block Diagram

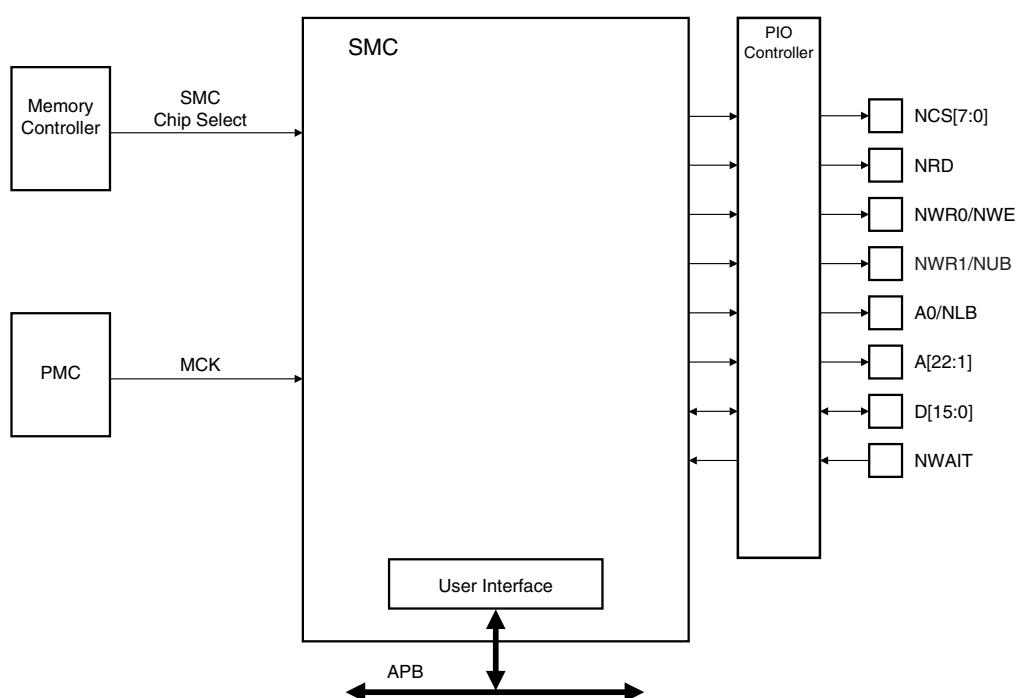

18.3 I/O Lines Description

Table 18-1. I/O Lines Description

Name	Description	Type	Active Level
NCS[7:0]	Static Memory Controller Chip Select Lines	Output	Low
NRD	Read Signal	Output	Low
NWR0/NWE	Write 0/Write Enable Signal	Output	Low
NWR1/NUB	Write 1/Upper Byte Select Signal	Output	Low
A0/NLB	Address Bit 0/Lower Byte Select Signal	Output	Low
A[22:1]	Address Bus	Output	
D[15:0]	Data Bus	I/O	
NWAIT	External Wait Signal	Input	Low

18.4 Multiplexed Signals

Table 18-2. Static Memory Controller Multiplexed Signals

Multiplexed Signals		Related Function
A0	NLB	8-bit or 16-bit data bus, see 18.6.1.3 “Data Bus Width” on page 158.
NWR0	NWE	Byte-write or byte-select access, see 18.6.2.1 “Write Access Type” on page 159.
NWR1	NUB	Byte-write or byte-select access, see 18.6.2.1 “Write Access Type” on page 159.

18.5 Product Dependencies

18.5.1 I/O Lines

The pins used for interfacing the Static Memory Controller may be multiplexed with the PIO lines. The programmer must first program the PIO controller to assign the Static Memory Controller pins to their peripheral function. If I/O lines of the Static Memory Controller are not used by the application, they can be used for other purposes by the PIO Controller.

18.6 Functional Description

18.6.1 External Memory Interface

18.6.1.1 External Memory Mapping

The memory map is defined by hardware and associates the internal 32-bit address space with the external 23-bit address bus. Note that A[22:0] is only significant for 8-bit memory. A[22:1] is used for 16-bit memory. If the physical memory device is smaller than the page size, it wraps around and appears to be repeated within the page. The SMC correctly handles any valid access to the memory device within the page. See [Figure 18-2](#).

Figure 18-2. Case of an External Memory Smaller than Page Size

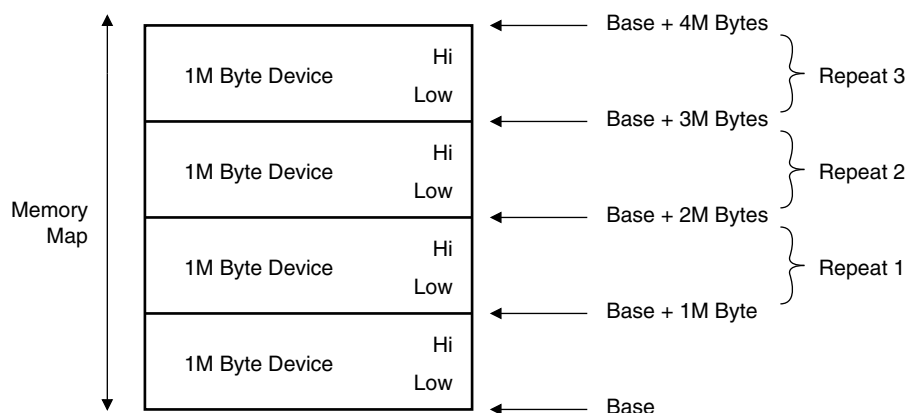

18.6.1.2 Chip Select Lines

The Static Memory Controller provides up to eight chip select lines: NCS0 to NCS7.

Figure 18-3. Memory Connections for Eight External Devices ⁽¹⁾

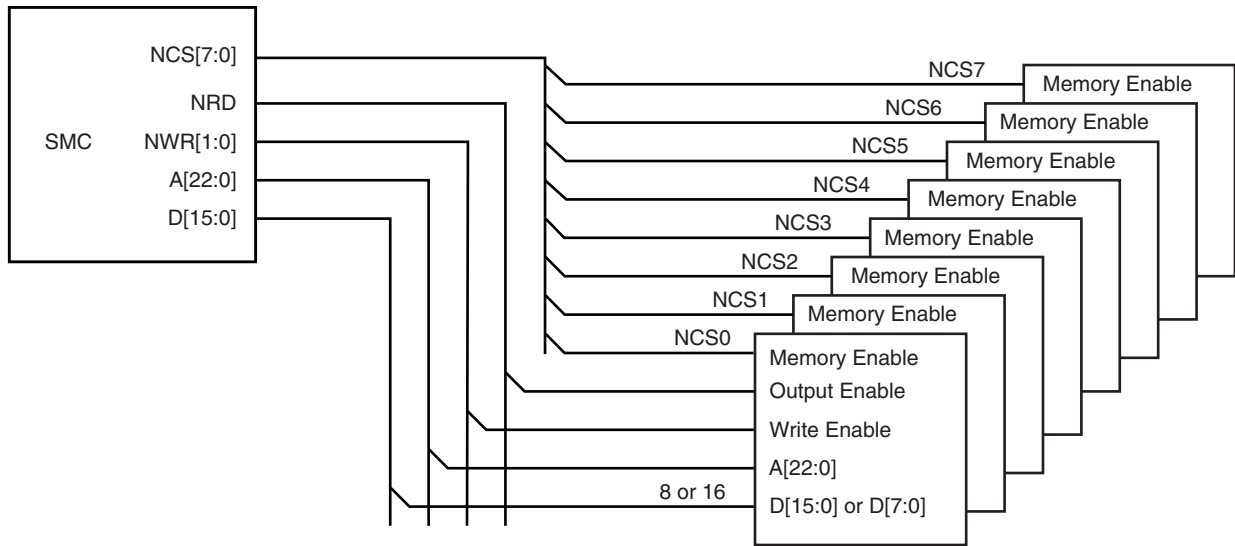

Note: 1. The maximum address space per device is 8 Mbytes.

18.6.1.3 Data Bus Width

A data bus width of 8 or 16 bits can be selected for each chip select. This option is controlled by the DBW field in the SMC_CSR for the corresponding chip select. See “SMC Chip Select Registers” on page 190.

Figure 18-4 shows how to connect a 512K x 8-bit memory on NCS2 (DBW = 10).

Figure 18-4. Memory Connection for an 8-bit Data Path Device

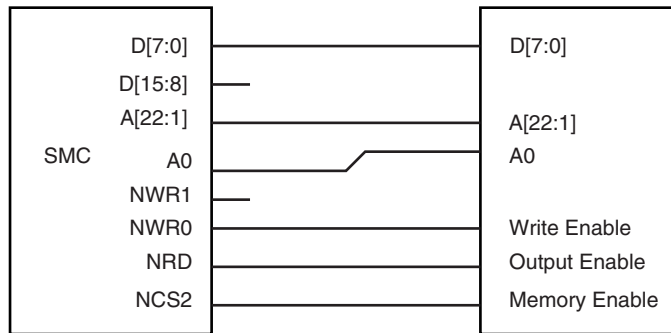
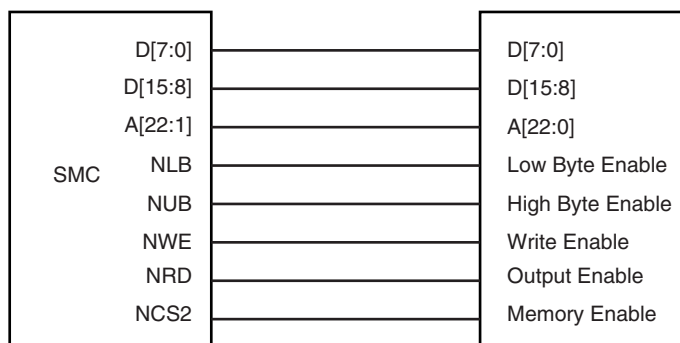

Figure 18-5 shows how to connect a 512K x 16-bit memory on NCS2 (DBW = 01).

Figure 18-5. Memory Connection for a 16-bit Data Path Device



18.6.2 Write Access

18.6.2.1 Write Access Type

Each chip select with a 16-bit data bus can operate with one of two different types of write access:

- Byte Write Access supports two byte write and a single read signal.
- Byte Select Access selects upper and/or lower byte with two byte select lines, and separate read and write signals.

This option is controlled by the BAT field in the SMC_CSR for the corresponding chip select. See “SMC Chip Select Registers” on page 190.

Byte Write Access

Byte Write Access is used to connect 2 x 8-bit devices as a 16-bit memory page.

- The signal A0/NLB is not used.
- The signal NWR1/NUB is used as NWR1 and enables upper byte writes.
- The signal NWR0/NWE is used as NWR0 and enables lower byte writes.
- The signal NRD enables half-word and byte reads.

Figure 18-6 shows how to connect two 512K x 8-bit devices in parallel on NCS2 (BAT = 0)

Figure 18-6. Memory Connection for 2 x 8-bit Data Path Devices

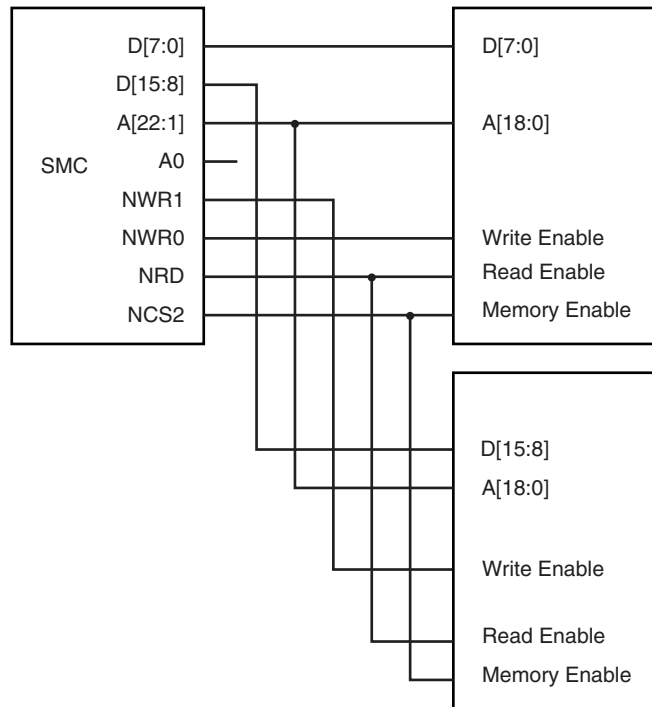

18.6.2.2 *Byte Select Access*

Byte Select Access is used to connect 16-bit devices in a memory page.

- The signal A0/NLB is used as NLB and enables the lower byte for both read and write operations.
- The signal NWR1/NUB is used as NUB and enables the upper byte for both read and write operations.
- The signal NWR0/NWE is used as NWE and enables writing for byte or half-word.
- The signal NRD enables reading for byte or half-word.

Figure 18-7 shows how to connect a 16-bit device with byte and half-word access (e.g., SRAM device type) on NCS2 (BAT = 1).

Figure 18-7. Connection to a 16-bit Data Path Device with Byte and Half-word Access

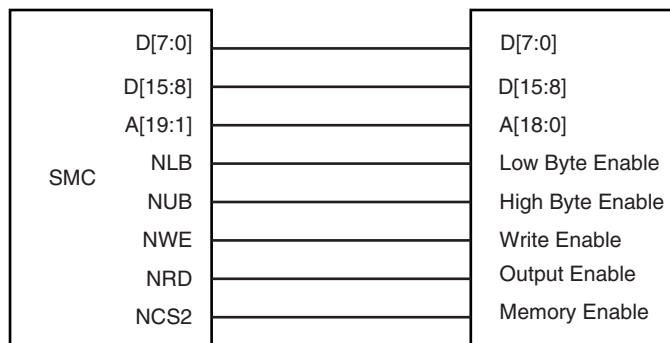
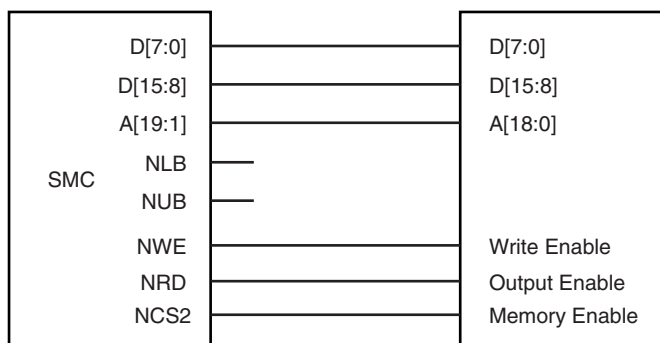

Figure 18-8 shows how to connect a 16-bit device without byte access (e.g., Flash device type) on NCS2 (BAT = 1).

Figure 18-8. Connection to a 16-bit Data Path Device without Byte Write Capability



18.6.2.3 Write Data Hold Time

During write cycles, data output becomes valid after the rising edge of MCK and remains valid after the rising edge of NWE. During a write access, the data remain on the bus 1/2 period of MCK after the rising edge of NWE. See [Figure 18-9](#) and [Figure 18-10](#).

Figure 18-9. Write Access with 0 Wait State

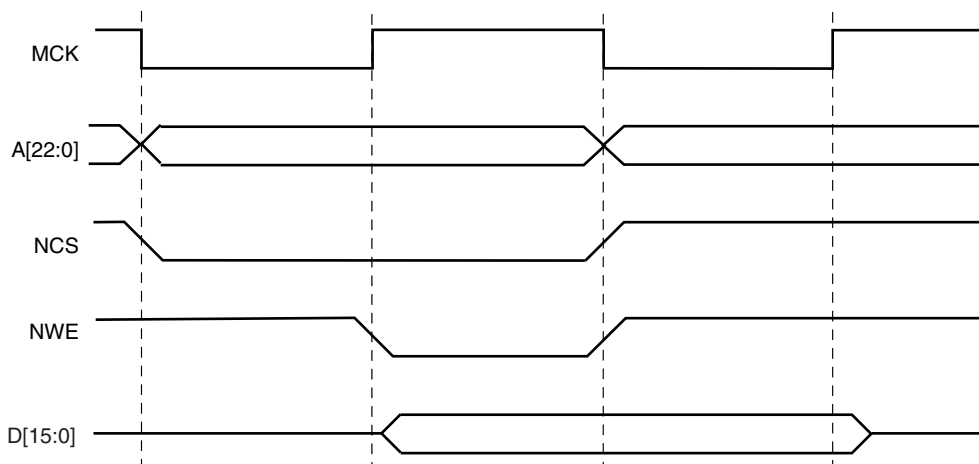
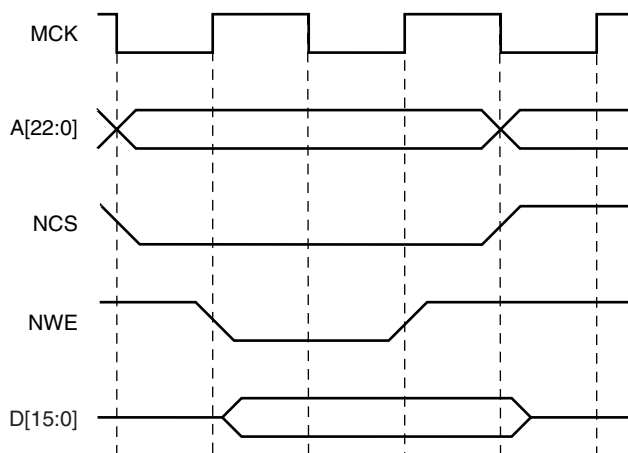

Figure 18-10. Write Access with 1 Wait State



18.6.3 Read Access

18.6.3.1 Read Protocols

The SMC provides two alternative protocols for external memory read accesses: standard and early read. The difference between the two protocols lies in the behavior of the NRD signal.

For write accesses, in both protocols, NWE has the same behavior. In the second half of the master clock cycle, NWE always goes low (see [Figure 18-18 on page 167](#)).

The protocol is selected by the DRP field in SMC_CSR (See “SMC Chip Select Registers” on [page 190](#)). Standard read protocol is the default protocol after reset.

Note: In the following waveforms and descriptions NWE represents NWE, NWR0 and NWR1 unless NWR0 and NWR1 are otherwise represented. In addition, NCS represents NCS[7:0] (see [18.5.1 “I/O Lines” on page 157](#), [Table 18-1](#) and [Table 18-2](#)).

18.6.3.2 Standard Read Protocol

Standard read protocol implements a read cycle during which NRD and NWE are similar. Both are active during the second half of the clock cycle. The first half of the clock cycle allows time to ensure completion of the previous access as well as the output of address lines and NCS before the read cycle begins.

During a standard read protocol, NCS is set low and address lines are valid at the beginning of the external memory access, while NRD goes low only in the second half of the master clock cycle to avoid bus conflict. See [Figure 18-11](#).

Figure 18-11. Standard Read Protocol

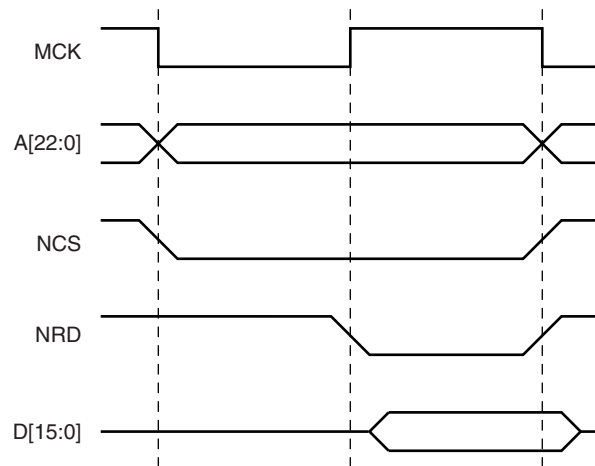

18.6.3.3 Early Read Protocol

Early read protocol provides more time for a read access from the memory by asserting NRD at the beginning of the clock cycle. In the case of successive read cycles in the same memory, NRD remains active continuously. Since a read cycle normally limits the speed of operation of the external memory system, early read protocol can allow a faster clock frequency to be used. However, an extra wait state is required in some cases to avoid contentions on the external bus.

Figure 18-12. Early Read Protocol

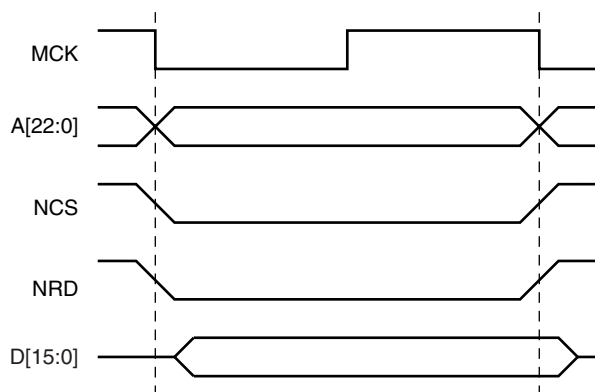

18.6.4 Wait State Management

The SMC can automatically insert wait states. The different types of wait states managed are listed below:

- Standard wait states
- External wait states
- Data float wait states
- Chip select change wait states
- Early Read wait states

18.6.4.1 Standard Wait States

Each chip select can be programmed to insert one or more wait states during an access on the corresponding memory area. This is done by setting the WSEN field in the corresponding SMC_CSR (“SMC Chip Select Registers” on page 190). The number of cycles to insert is programmed in the NWS field in the same register.

Below is the correspondence between the number of standard wait states programmed and the number of clock cycles during which the NWE pulse is held low:

0 wait states	1/2 clock cycle
1 wait state	1 clock cycle

For each additional wait state programmed, an additional cycle is added.

Figure 18-13. One Standard Wait State Access

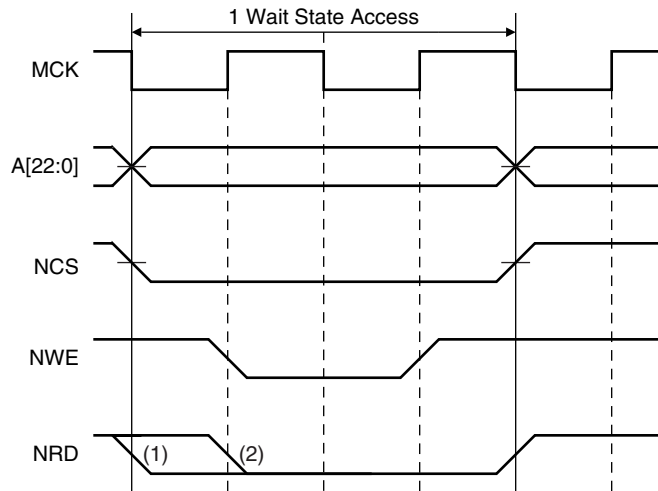

- Notes: 1. Early Read Protocol
2. Standard Read Protocol

18.6.4.2 External Wait States

The NWAIT input pin is used to insert wait states beyond the maximum standard wait states programmable or in addition to. If NWAIT is asserted low, then the SMC adds a wait state and no changes are made to the output signals, the internal counters or the state. When NWAIT is deasserted, the SMC completes the access sequence.

WARNING: Asserting NWAIT low stops the core's clock and thus stops program execution.

The input of the NWAIT signal is an asynchronous input. To avoid any metastability problems, NWAIT is synchronized before using it. This operation results in a two-cycle delay.

NWS must be programmed as a function of synchronization time and delay between NWAIT falling and control signals falling (NRD/NWE), otherwise SMC will not function correctly.

$$NWS \geq \text{Wait Delay from nrd/nwe} + \text{external_nwait Synchronization Delay} + 1$$

Note: Where external NWAIT synchronization is equal to 2 cycles.
The minimum value for NWS if NWAIT is used, is 3.

WARNING: If NWAIT is asserted during a setup or hold timing, the SMC does not function correctly.

Figure 18-14. NWAIT Behavior in Read Access [NWS = 3]

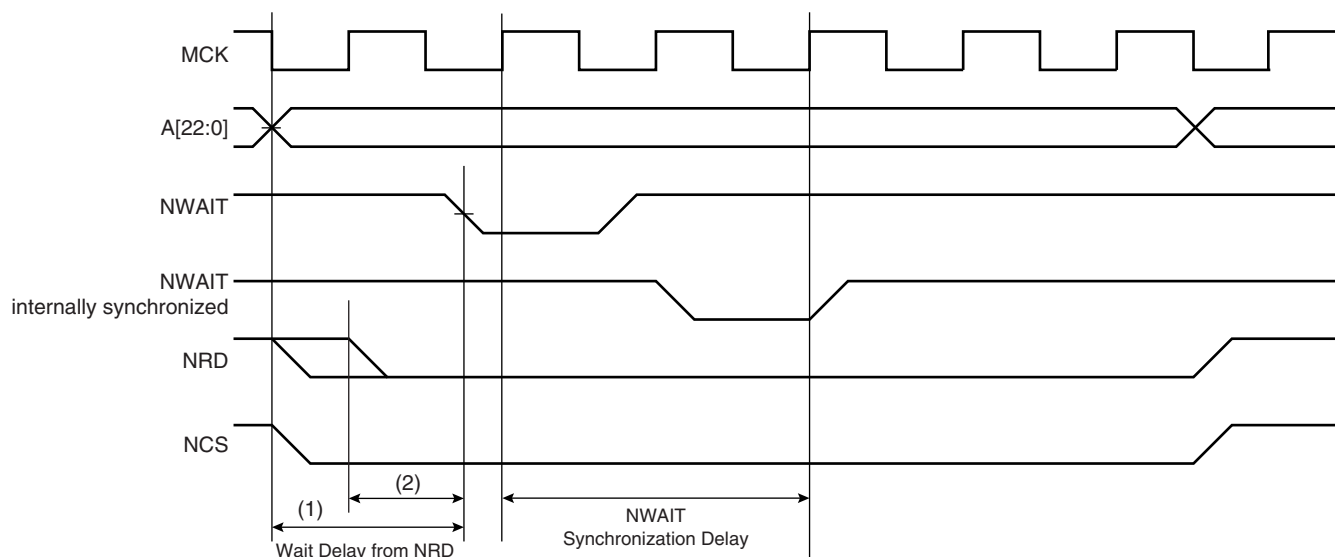

- Notes: 1. Early Read Protocol
2. Standard Read Protocol

Figure 18-15. NWAIT Behavior in Write Access [NWS = 3]

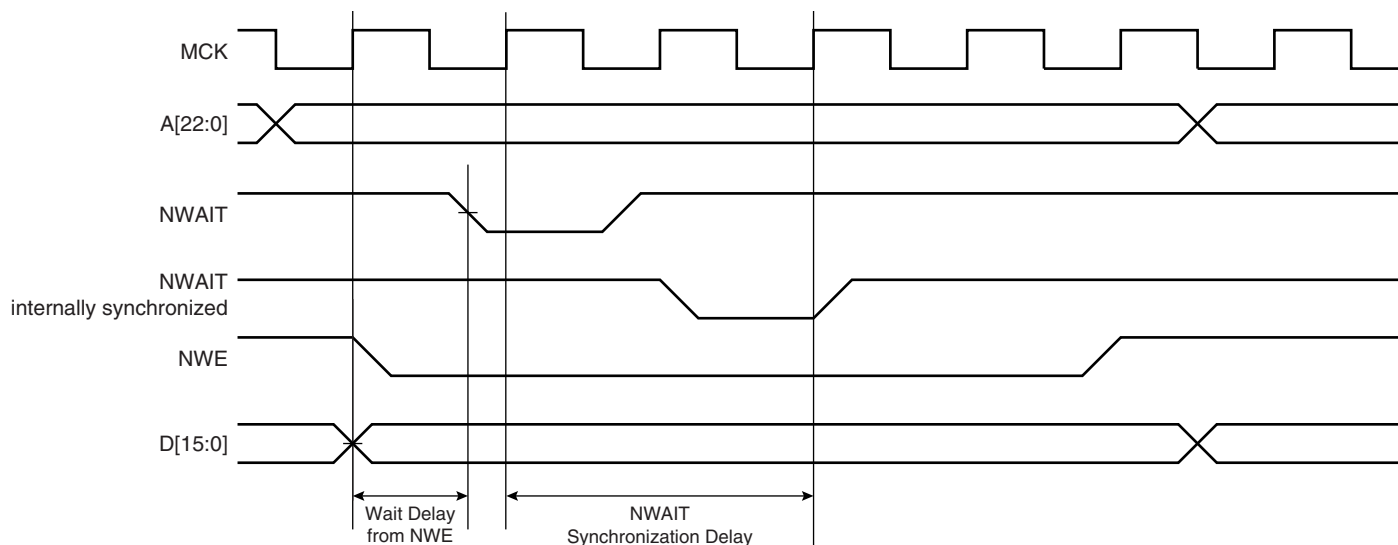

18.6.4.3 Data Float Wait States

Some memory devices are slow to release the external bus. For such devices, it is necessary to add wait states (data float wait states) after a read access before starting a write access or a read access to a different external memory.

The Data Float Output Time (t_{DF}) for each external memory device is programmed in the TDF field of the SMC_CSR register for the corresponding chip select ("[SMC Chip Select Registers](#)")

on page 190). The value of TDF indicates the number of data float wait cycles (between 0 and 15) to be inserted and represents the time allowed for the data output to go to high impedance after the memory is disabled.

Data float wait states do not delay internal memory accesses. Hence, a single access to an external memory with long t_{DF} will not slow down the execution of a program from internal memory.

To ensure that the external memory system is not accessed while it is still busy, the SMC keeps track of the programmed external data float time during internal accesses.

Internal memory accesses and consecutive read accesses to the same external memory do not add data float wait states.

Figure 18-16. Data Float Output Delay

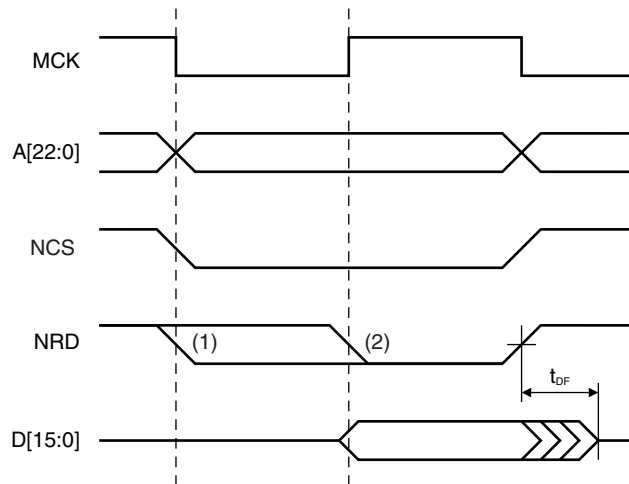

- Notes:
1. Early Read Protocol
 2. Standard Read Protocol

18.6.4.4 Chip Select Change Wait State

A chip select wait state is automatically inserted when consecutive accesses are made to two different external memories (if no other type of wait state has already been inserted). If a wait state has already been inserted (e.g., data float wait state), then no more wait states are added.

Figure 18-17. Chip Select Wait State

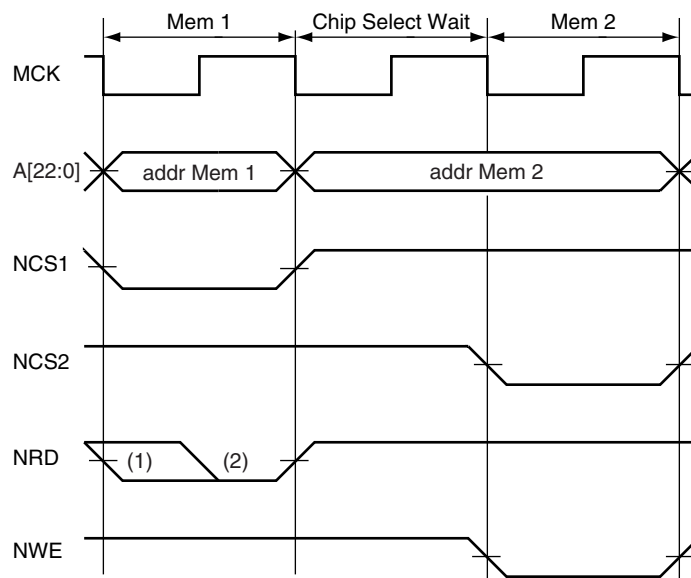

- Notes: 1. Early Read Protocol
2. Standard Read Protocol

18.6.4.5 Early Read Wait State

In early read protocol, an early read wait state is automatically inserted when an external write cycle is followed by a read cycle to allow time for the write cycle to end before the subsequent read cycle begins (see Figure 18-18). This wait state is generated in addition to any other programmed wait states (i.e., data float wait state).

No wait state is added when a read cycle is followed by a write cycle, between consecutive accesses of the same type, or between external and internal memory accesses.

Figure 18-18. Early Read Wait States

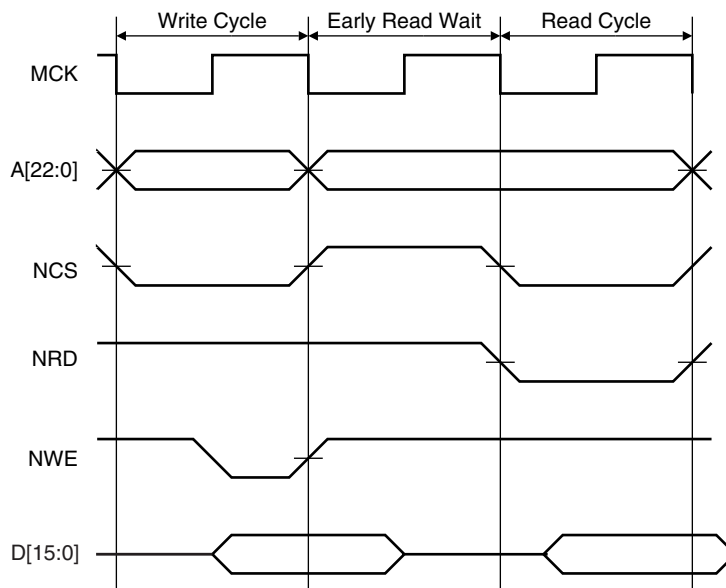

18.6.5 Setup and Hold Cycles

The SMC allows some memory devices to be interfaced with different setup, hold and pulse delays. These parameters are programmable and define the timing of each portion of the read and write cycles. However, it is not possible to use this feature in early read protocol.

If an attempt is made to program the setup parameter as not equal to zero and the hold parameter as equal to zero with WSEN = 0 (0 standard wait state), the SMC does not operate correctly.

If consecutive accesses are made to two different external memories and the second memory is programmed with setup cycles, then no chip select change wait state is inserted (see [Figure 18-23 on page 170](#)).

When a data float wait state (t_{DF}) is programmed on the first memory bank and when the second memory bank is programmed with setup cycles, the SMC behaves as follows:

- If the number of t_{DF} is higher or equal to the number of setup cycles, the number of setup cycles inserted is equal to 0 (see [Figure 18-24 on page 170](#)).
- If the number of the setup cycle is higher than the number of t_{DF} , the number of t_{DF} inserted is 0 (see [Figure 18-25 on page 171](#)).

18.6.5.1 Read Access

The read cycle can be divided into a setup, a pulse length and a hold. The setup parameter can have a value between 1.5 and 7.5 clock cycles, the hold parameter between 0 and 7 clock cycles and the pulse length between 1.5 and 128.5 clock cycles, by increments of one.

Figure 18-19. Read Access with Setup and Hold

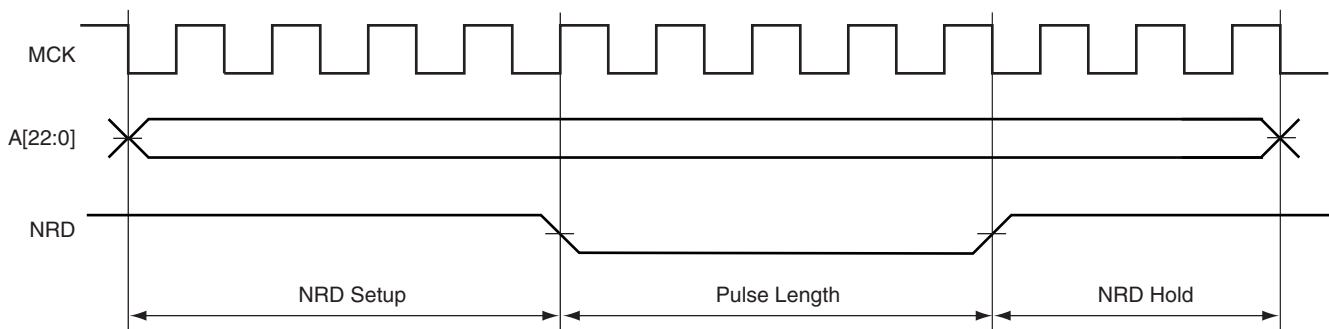
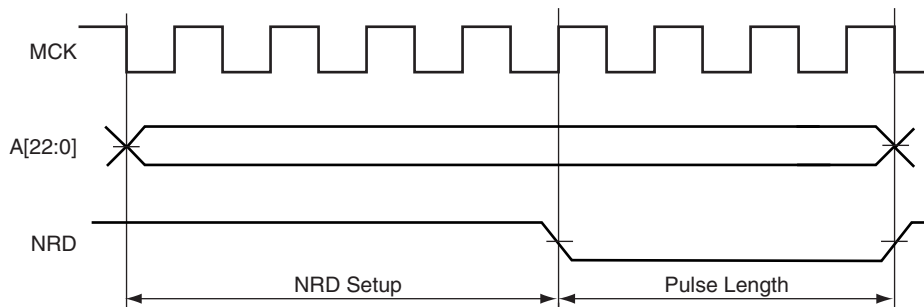

Figure 18-20. Read Access with Setup



18.6.5.2 Write Access

The write cycle can be divided into a setup, a pulse length and a hold. The setup parameter can have a value between 1.5 and 7.5 clock cycles, the hold parameter between 0.5 and 7 clock cycles and the pulse length between 1 and 128 clock cycles by increments of one.

Figure 18-21. Write Access with Setup and Hold

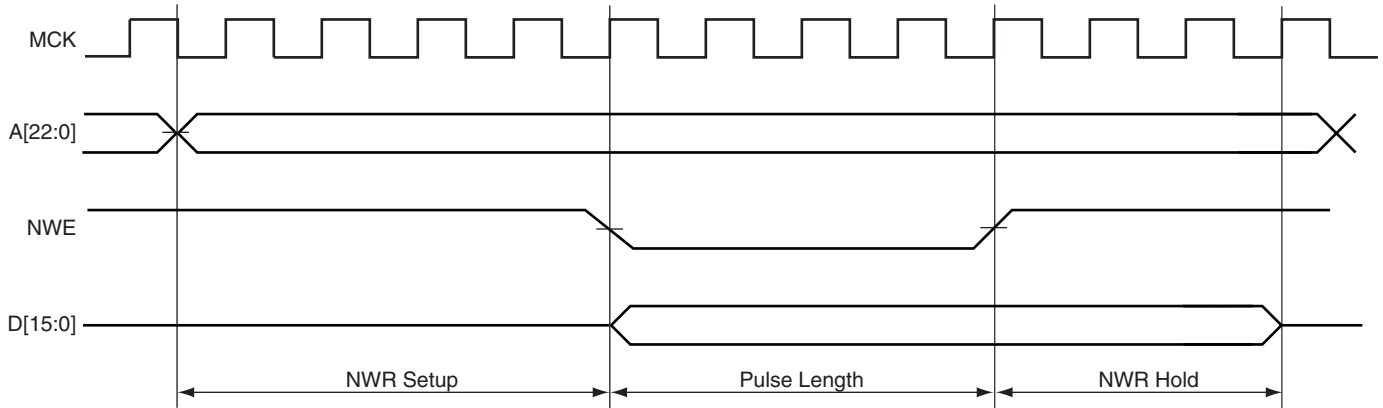
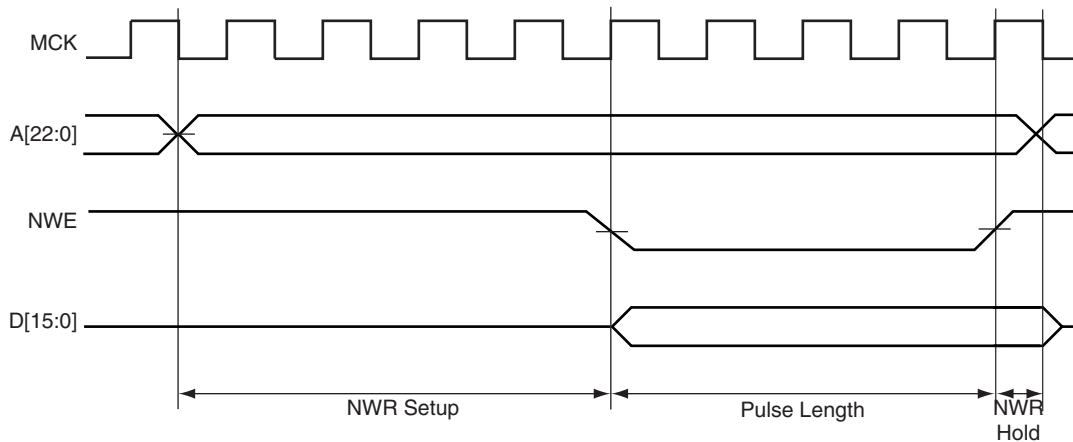

Figure 18-22. Write Access with Setup



18.6.5.3 Data Float Wait States with Setup Cycles

Figure 18-23. Consecutive Accesses with Setup Programmed on the Second Access

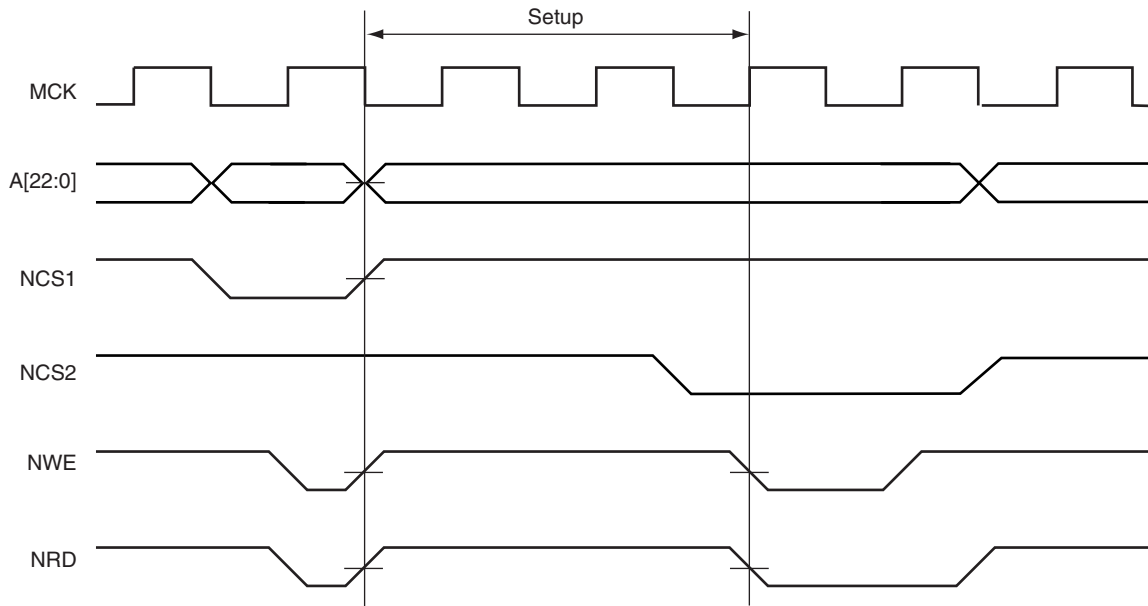

Figure 18-24. First Access with Data Float Wait States (TDF = 2) and Second Access with Setup (NRDSETUP = 1)

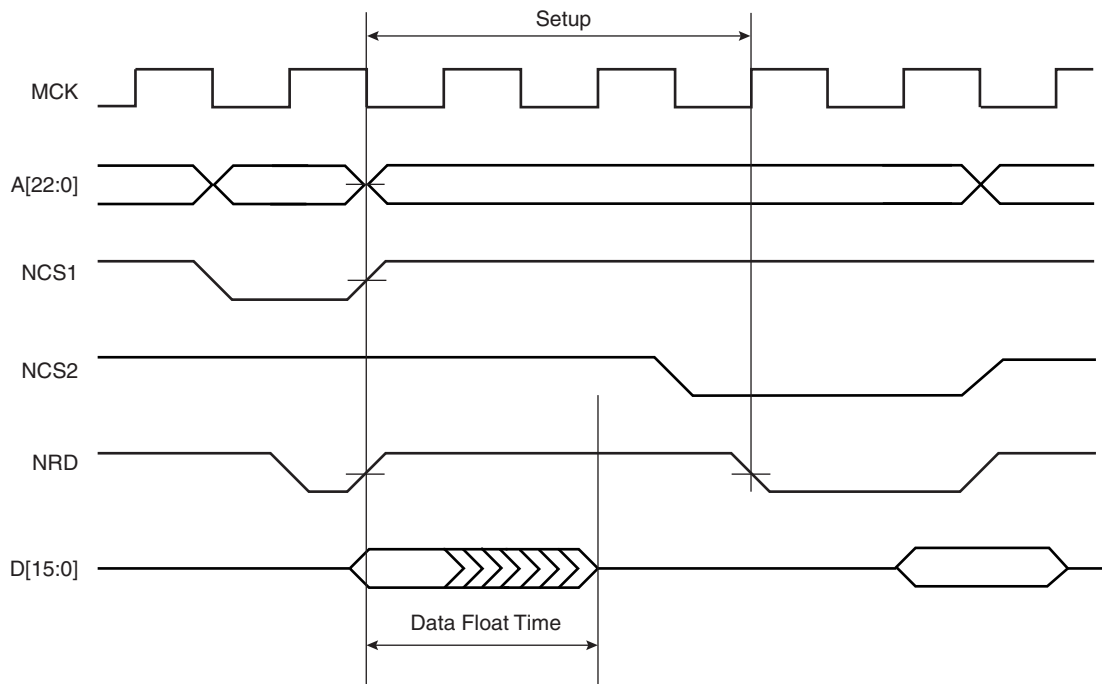
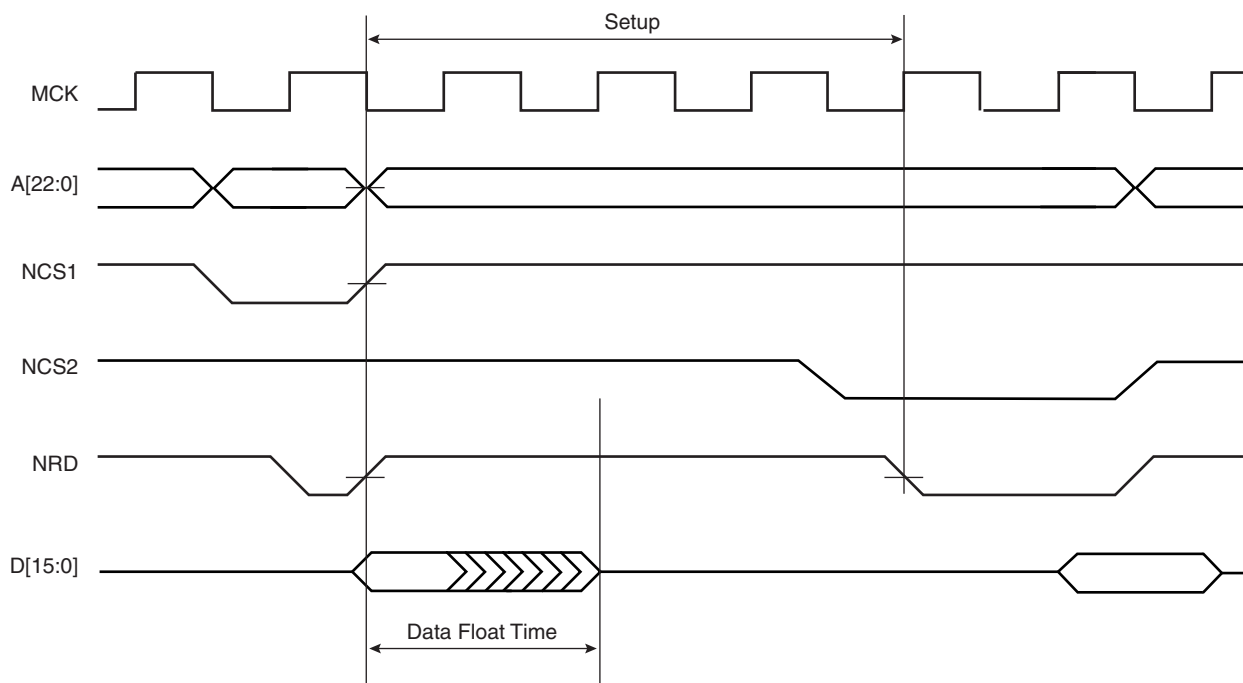

Figure 18-25. First Access with Data Float Wait States (TDF = 2) and Second Access with Setup (NRDSETUP = 3)



18.6.6 LCD Interface Mode

The SMC can be configured to work with an external liquid crystal display (LCD) controller by setting the ACSS (Address to Chip Select Setup) bit in the SMC_CSR registers ([“SMC Chip Select Registers” on page 190](#)).

In LCD mode, NCS is shortened by one/two/three clock cycles at the leading and trailing edges, providing positive address setup and hold. For read accesses, the data is latched in the SMC when NCS is raised at the end of the access.

Additionally, WSEN must be set and NWS programmed with a value of two or more superior to ACSS. In LCD mode, it is not recommended to use RWHOLD or RWSETUP. If the above conditions are not satisfied, SMC does not operate correctly.

Figure 18-26. Read Access in LCD Interface Mode

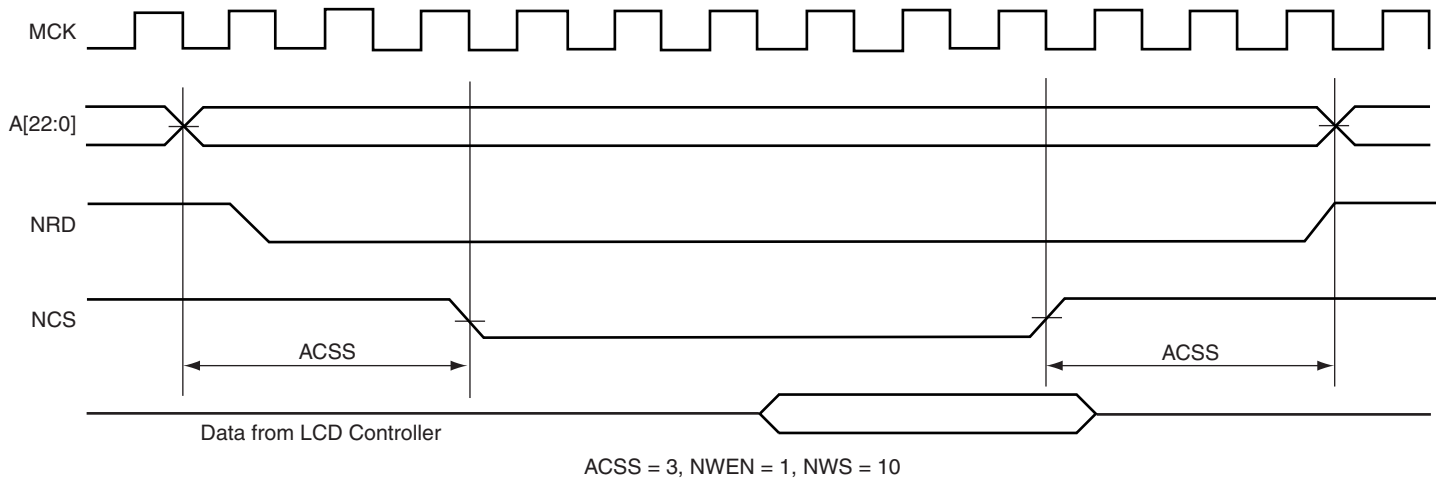
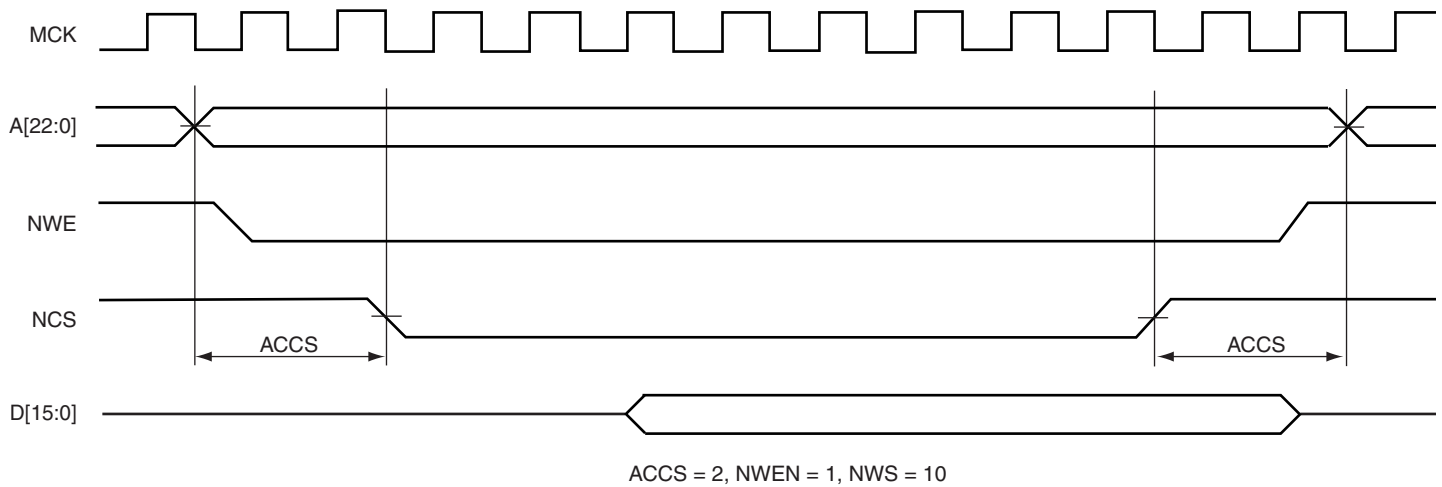

Figure 18-27. Write Access in LCD Interface Mode



18.6.7 Memory Access Waveforms

18.6.7.1 Read Accesses in Standard and Early Protocols

Figure 18-28 on page 173 through Figure 18-31 on page 176 show examples of the alternatives for external memory read protocol.

Figure 18-28. Standard Read Protocol without t_{DF}

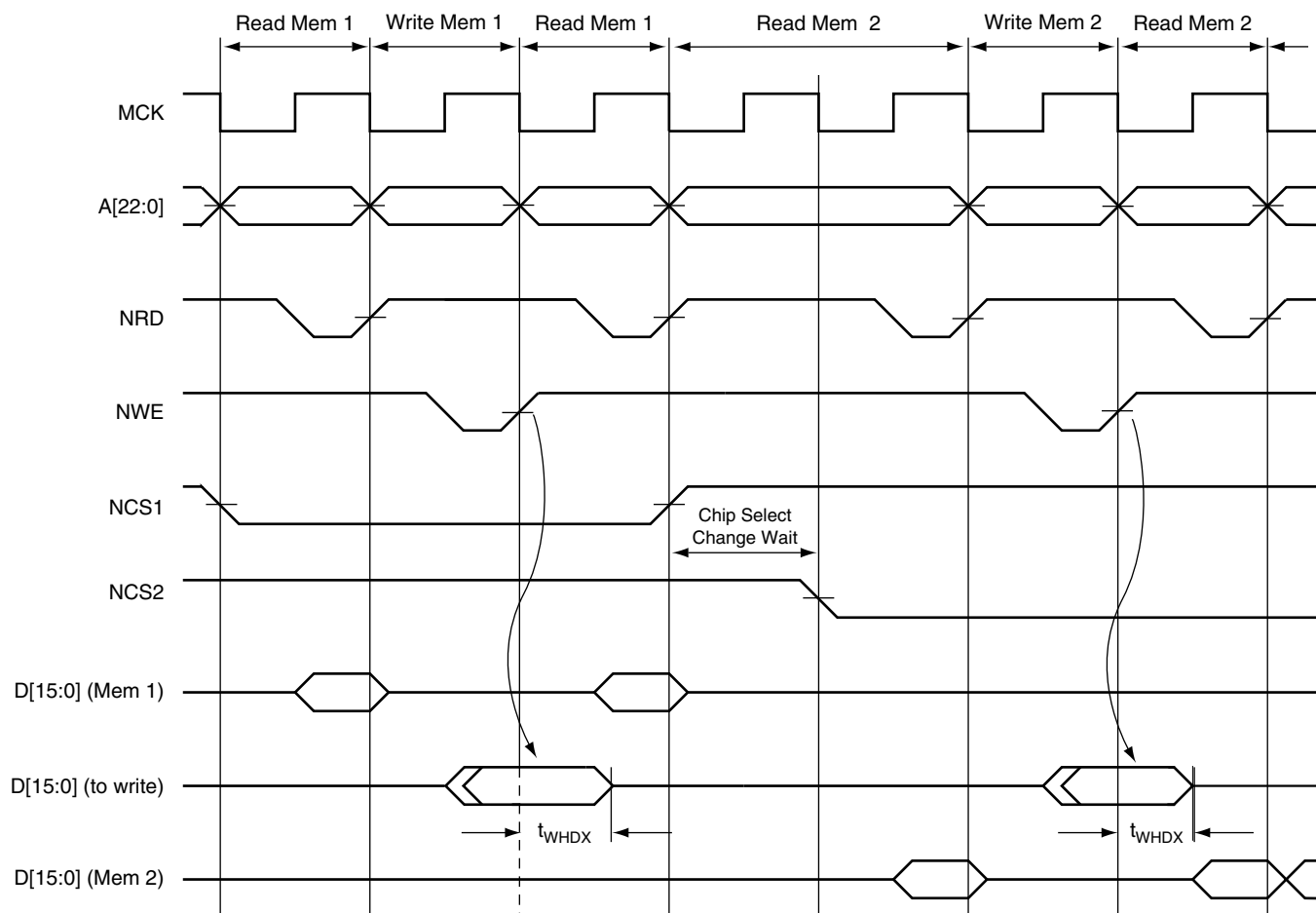

Figure 18-29. Early Read Protocol without t_{DF}

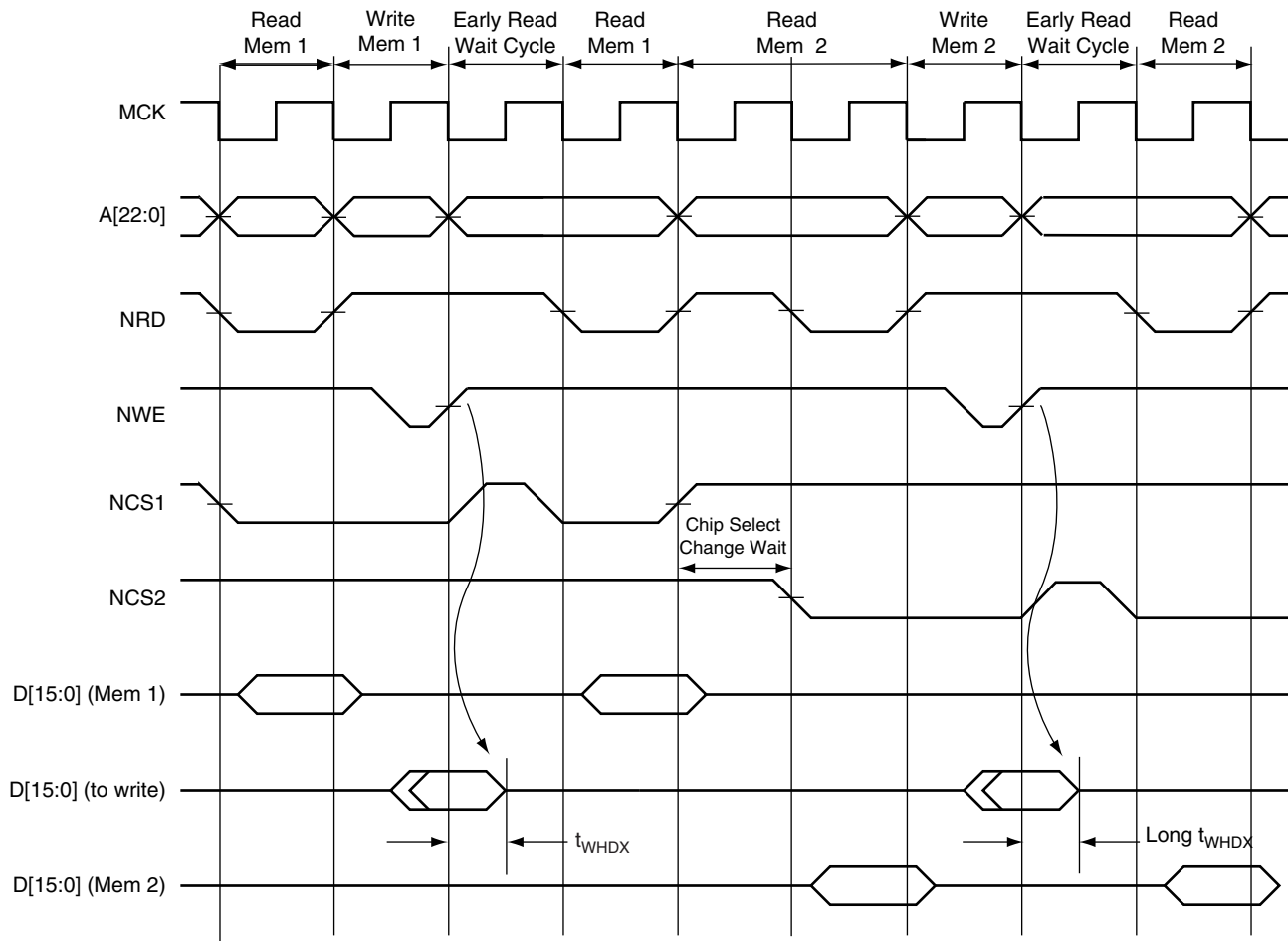

Figure 18-30. Standard Read Protocol with t_{DF}

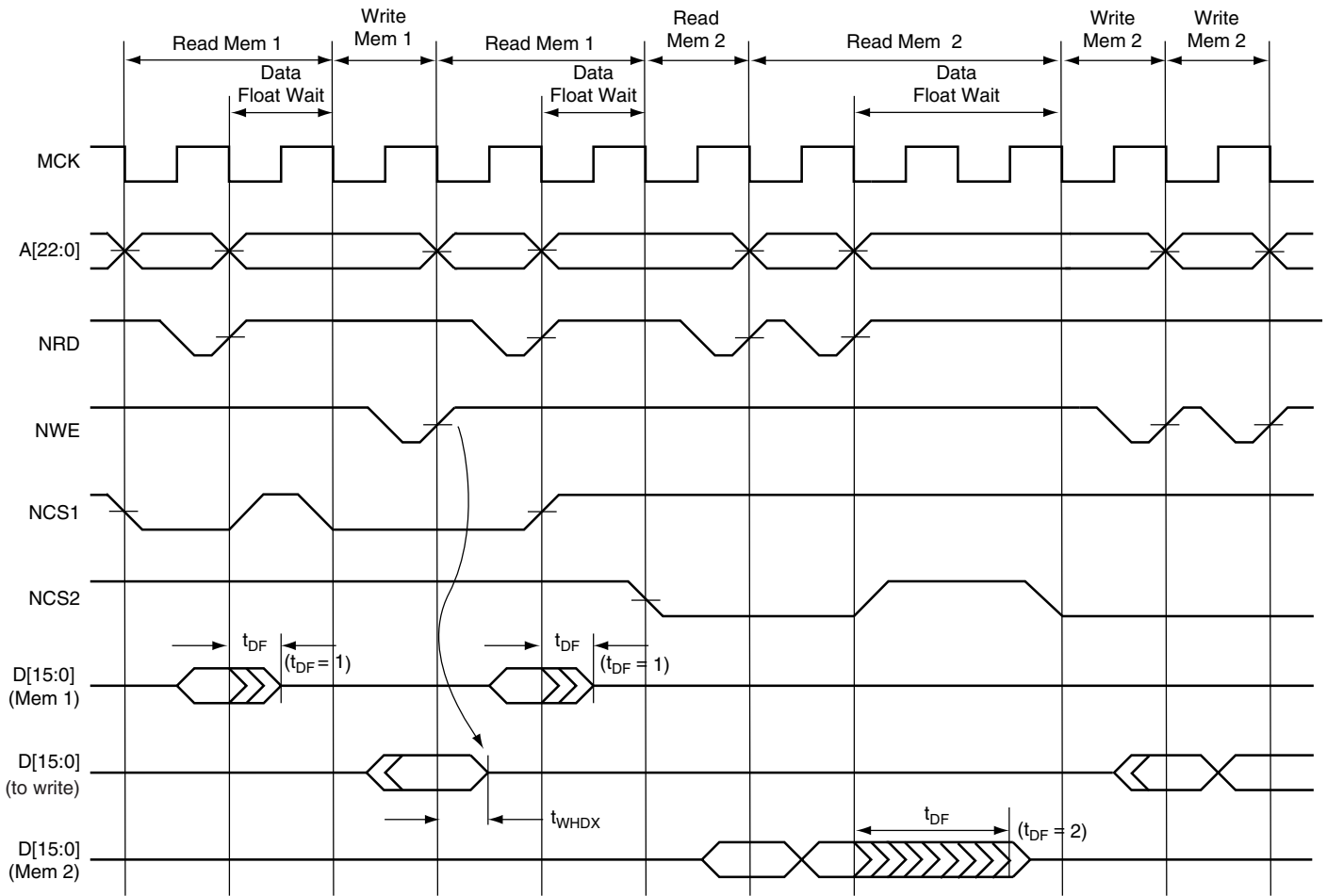
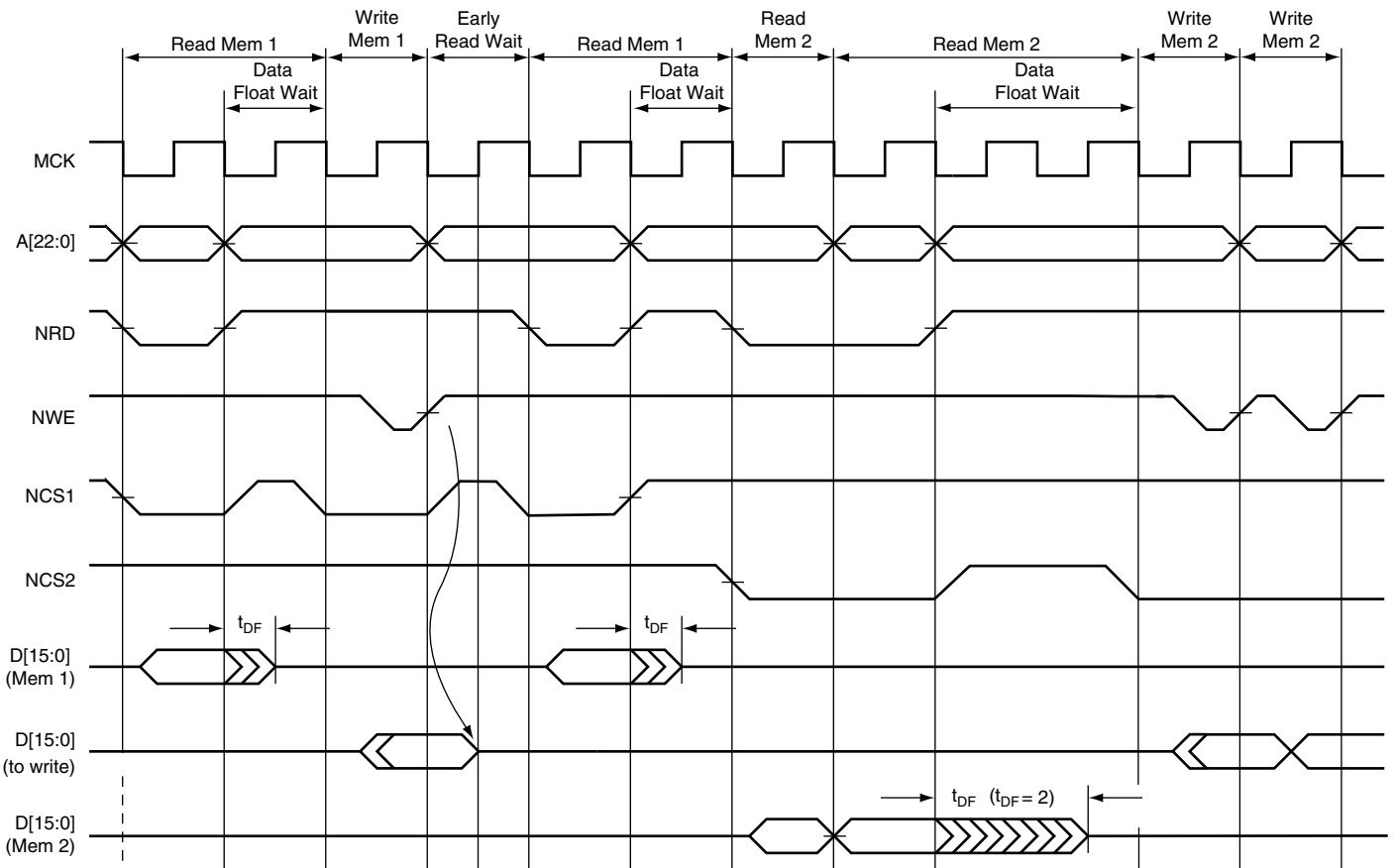

Figure 18-31. Early Read Protocol with t_{DF}



18.6.7.2 Accesses with Setup and Hold

Figure 18-32 and Figure 18-33 show an example of read and write accesses with Setup and Hold Cycles.

Figure 18-32. Read Accesses in Standard Read Protocol with Setup and Hold⁽¹⁾

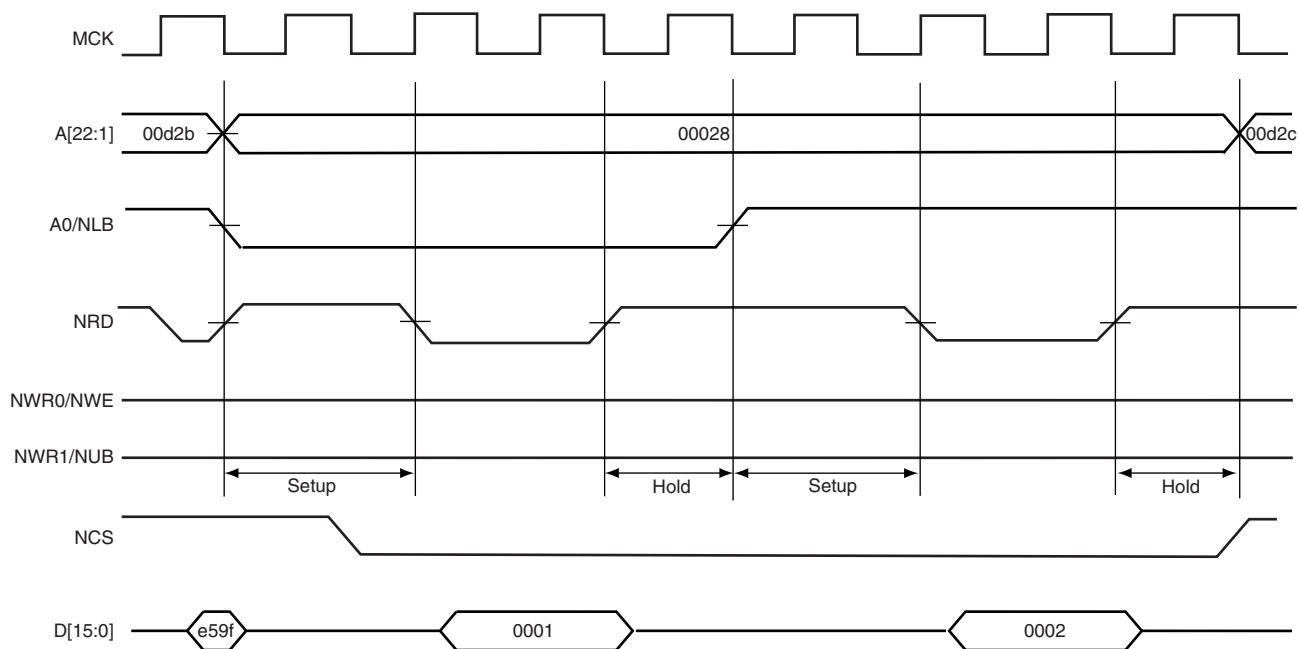

Note: 1. Read access, memory data bus width = 8, RWSETUP = 1, RWHOLD = 1, WSEN = 1, NWS = 0

Figure 18-33. Write Accesses with Setup and Hold⁽¹⁾

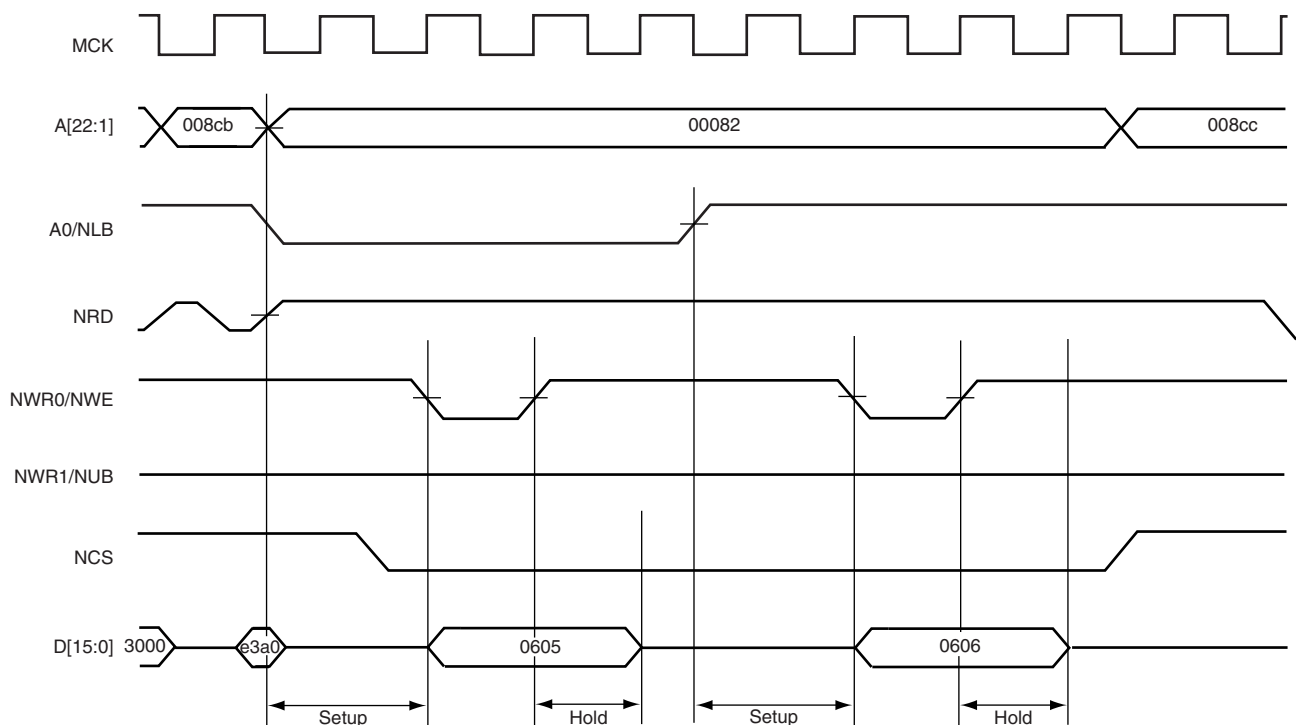

Note: 1. Write access, memory data bus width = 8, RWSETUP = 1, RWHOLD = 1, WSEN = 1, NWS = 0

18.6.7.3 Accesses Using NWAIT Input Signal

Figure 18-34 on page 178 through Figure 18-37 on page 181 show examples of accesses using NWAIT.

Figure 18-34. Write Access using NWAIT in Byte Select Type Access⁽¹⁾

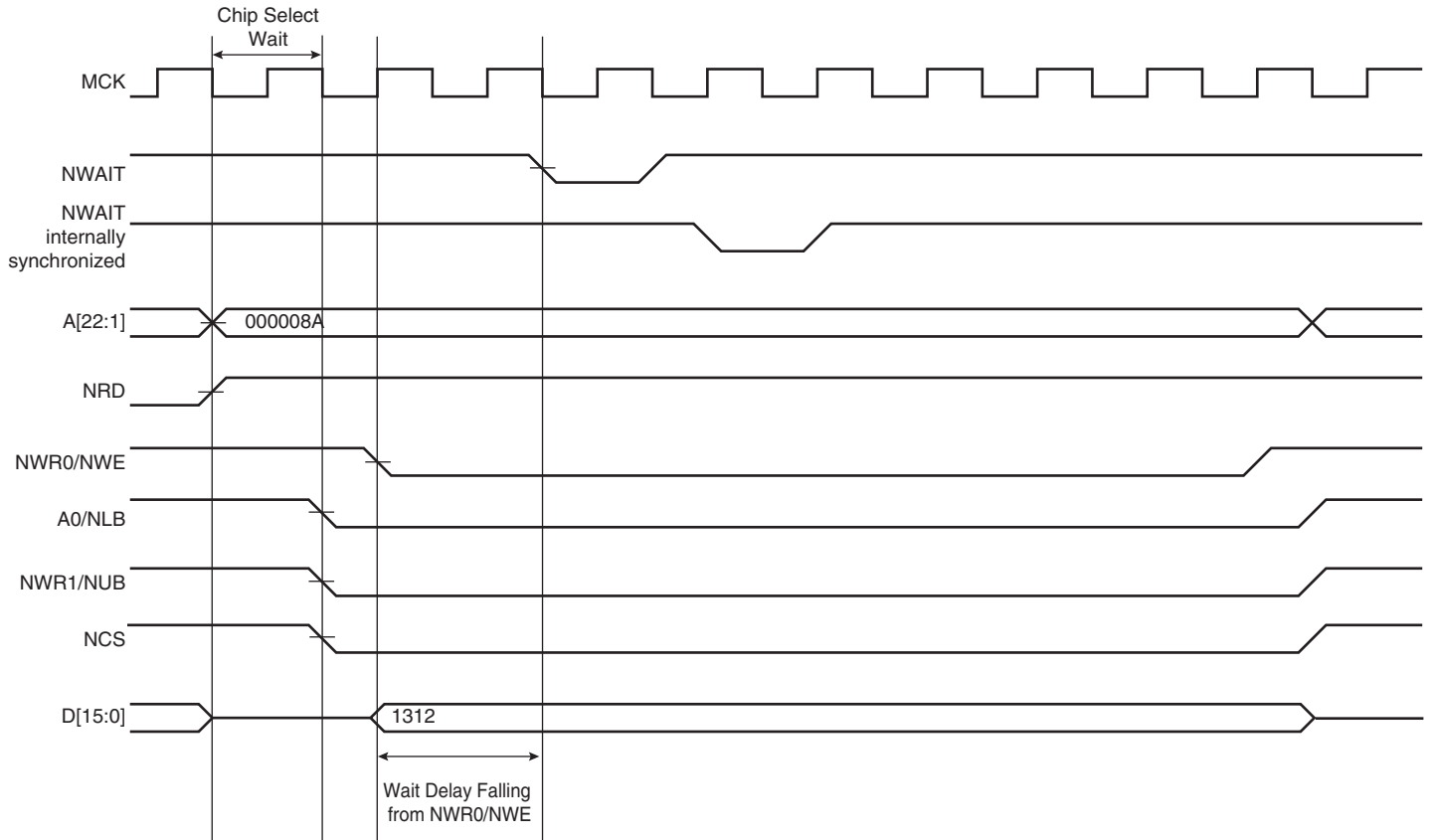

Note: 1. Write access memory, data bus width = 16 bits, WSEN = 1, NWS = 6

Figure 18-35. Write Access using NWAIT in Byte Write Type Access⁽¹⁾

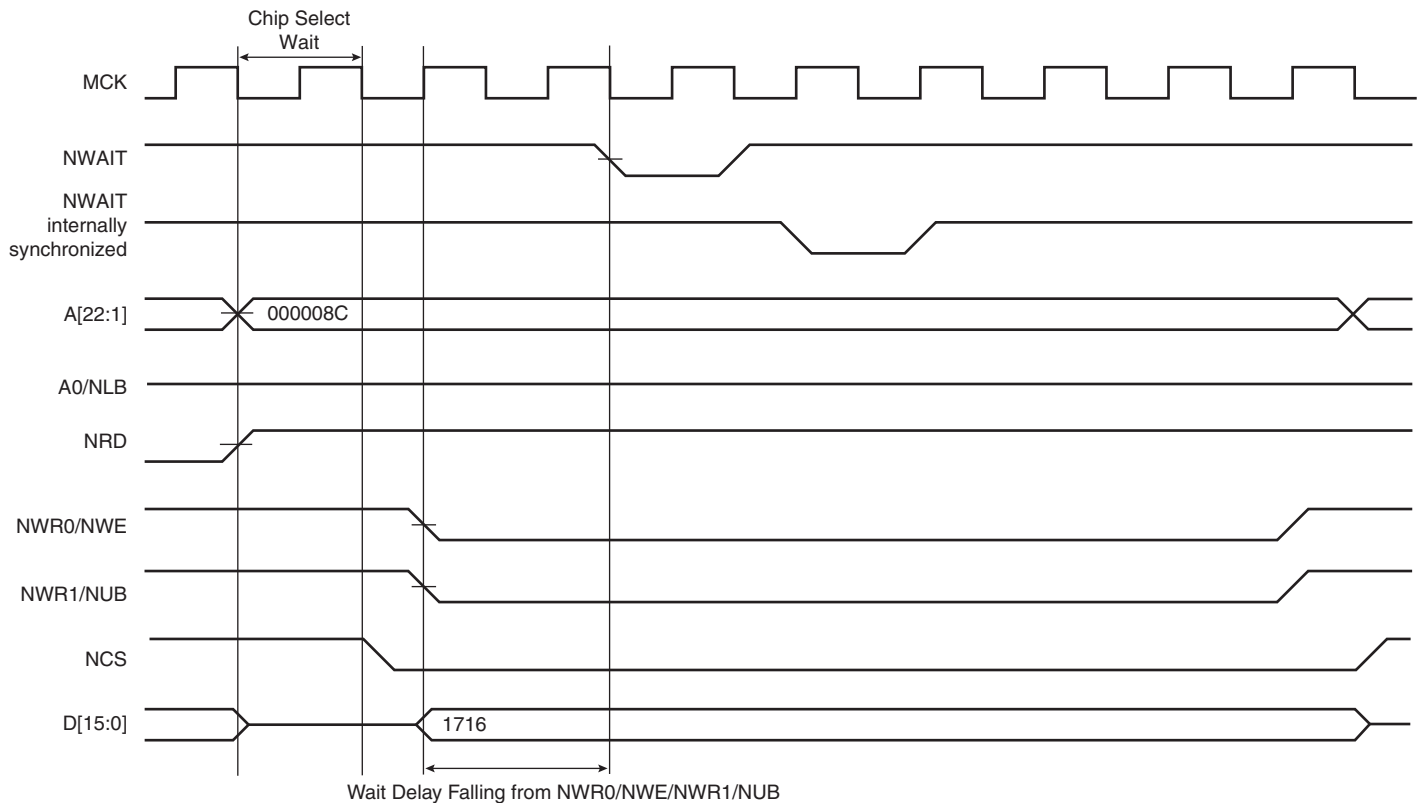

Note: 1. Write access memory, data bus width = 16 bits, WSEN = 1, NWS = 5

Figure 18-36. Write Access using NWAIT⁽¹⁾

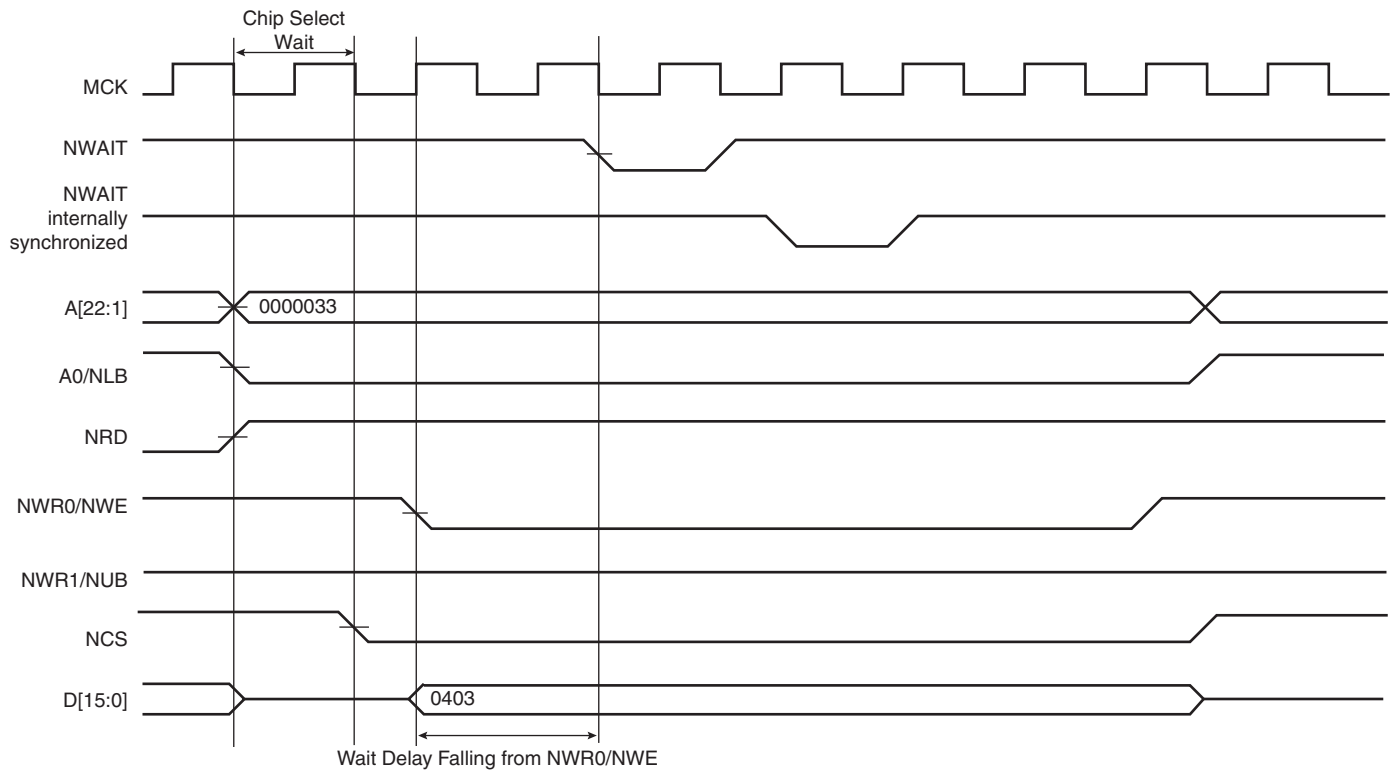

Note: 1. Write access memory, data bus width = 8 bits, WSEN = 1, NWS = 4

Figure 18-37. Read Access in Standard Protocol using NWAIT⁽¹⁾

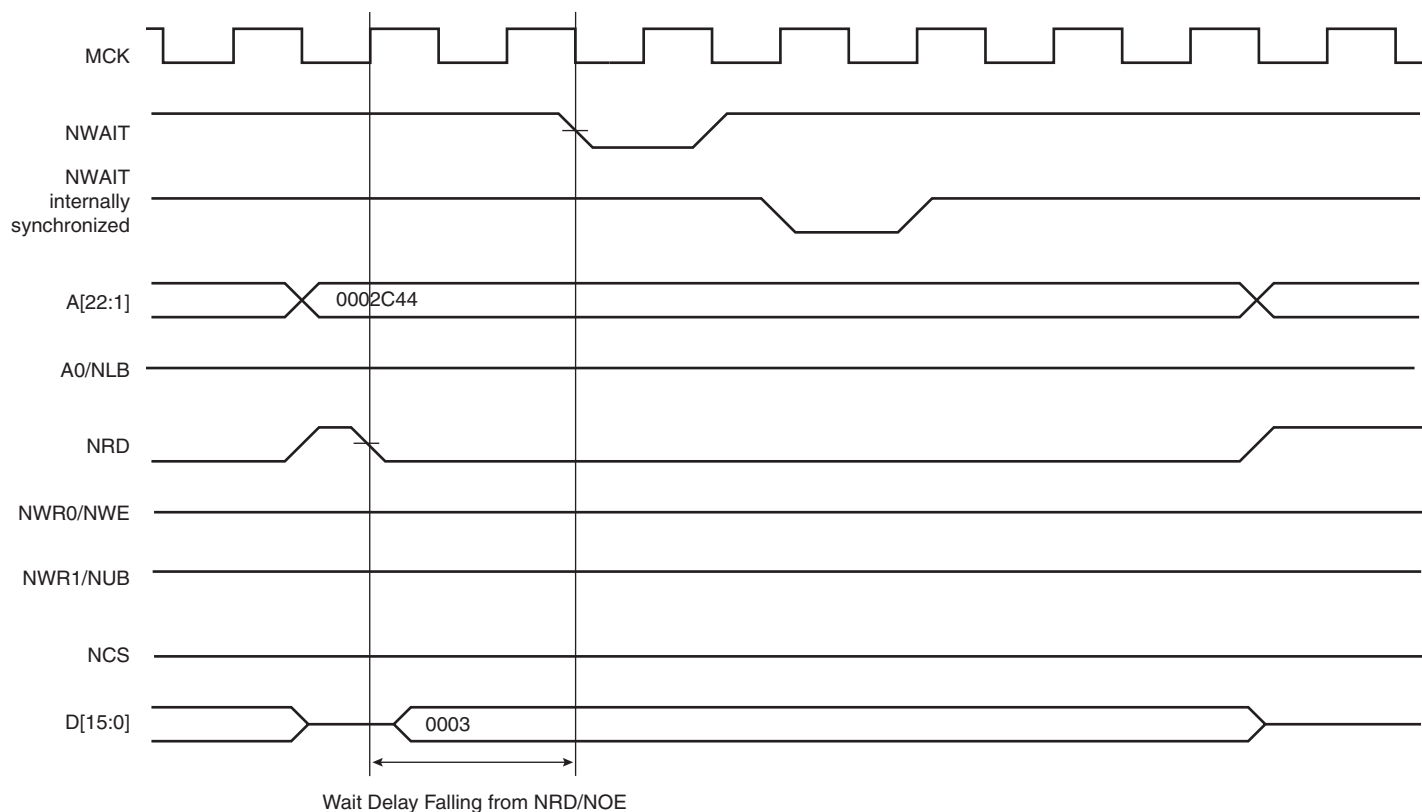

Note: 1. Read access, memory data bus width = 16, NWS = 5, WSEN = 1

18.6.7.4 Memory Access Example Waveforms

Figure 18-38 on page 182 through Figure 18-44 on page 188 show the waveforms for read and write accesses to the various associated external memory devices. The configurations described are shown in Table 18-3.

Table 18-3. Memory Access Waveforms

Figure Number	Number of Wait States	Bus Width	Size of Data Transfer
Figure 18-38	0	16	Word
Figure 18-39	1	16	Word
Figure 18-40	1	16	Half-word
Figure 18-41	0	8	Word
Figure 18-42	1	8	Half-word
Figure 18-43	1	8	Byte
Figure 18-44	0	16	Byte

Figure 18-38. 0 Wait State, 16-bit Bus Width, Word Transfer

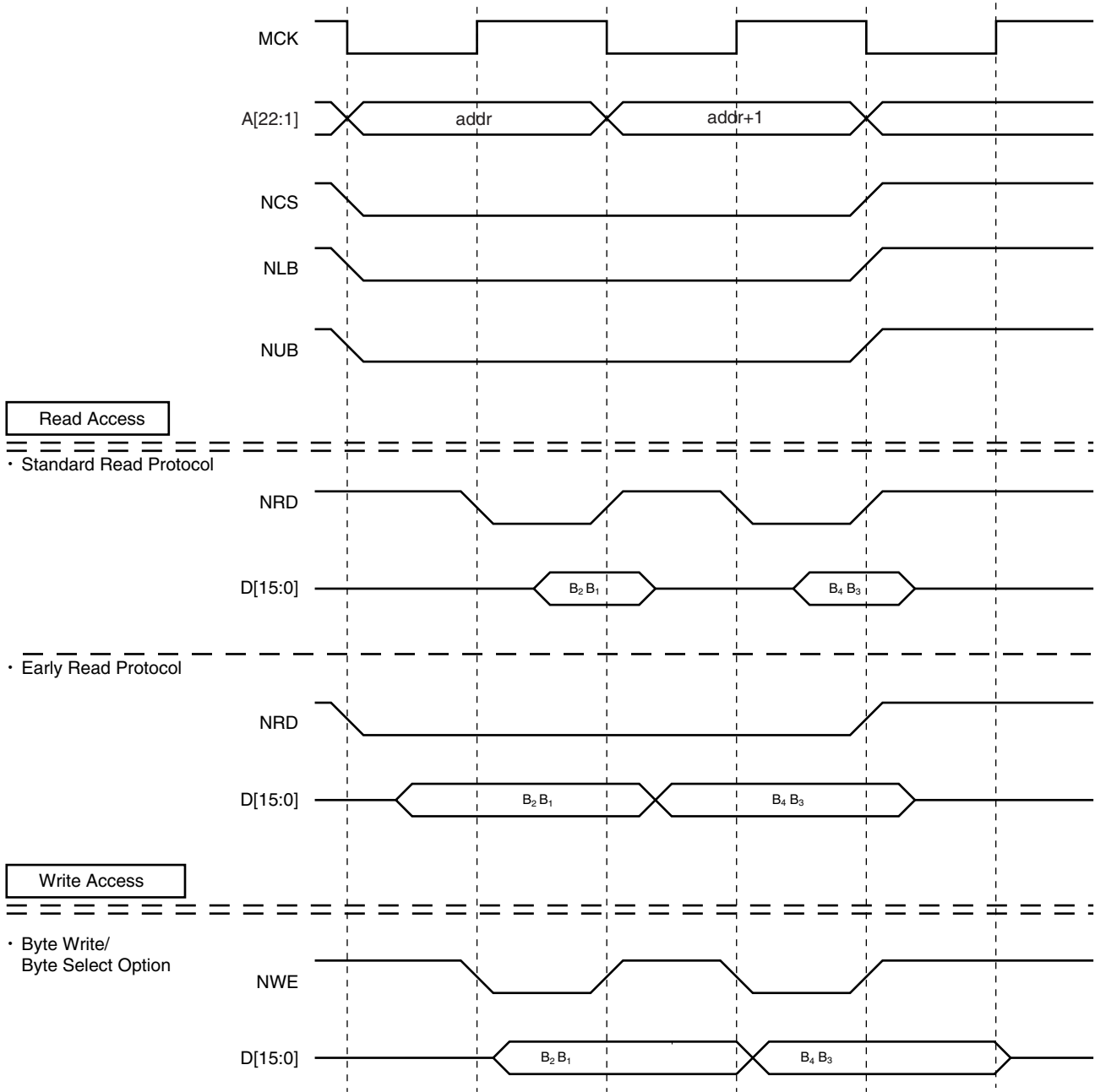

Figure 18-39. 1 Wait State, 16-bit Bus Width, Word Transfer

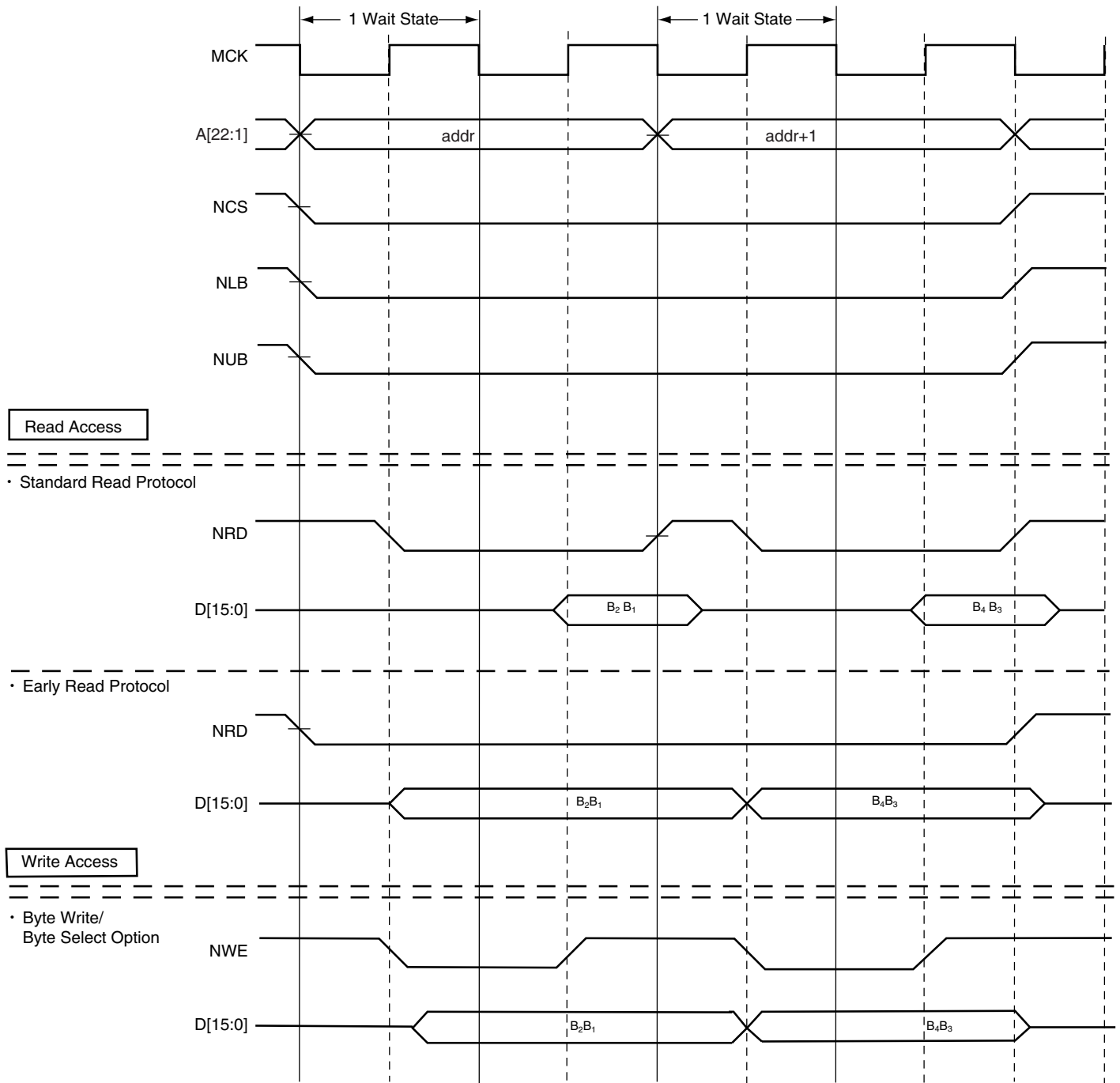

Figure 18-40. 1 Wait State, 16-bit Bus Width, Half-Word Transfer

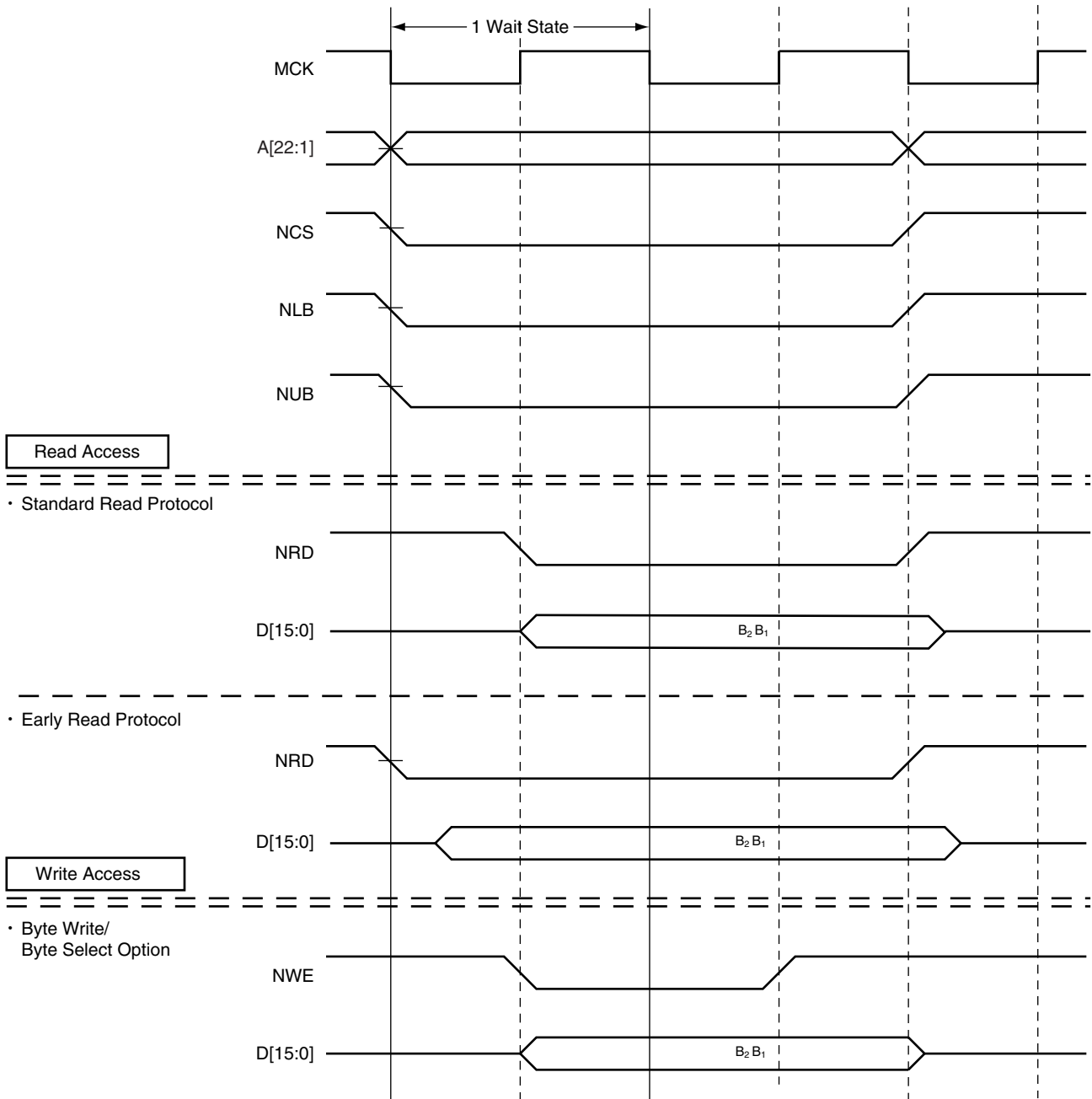

Figure 18-41. 0 Wait State, 8-bit Bus Width, Word Transfer

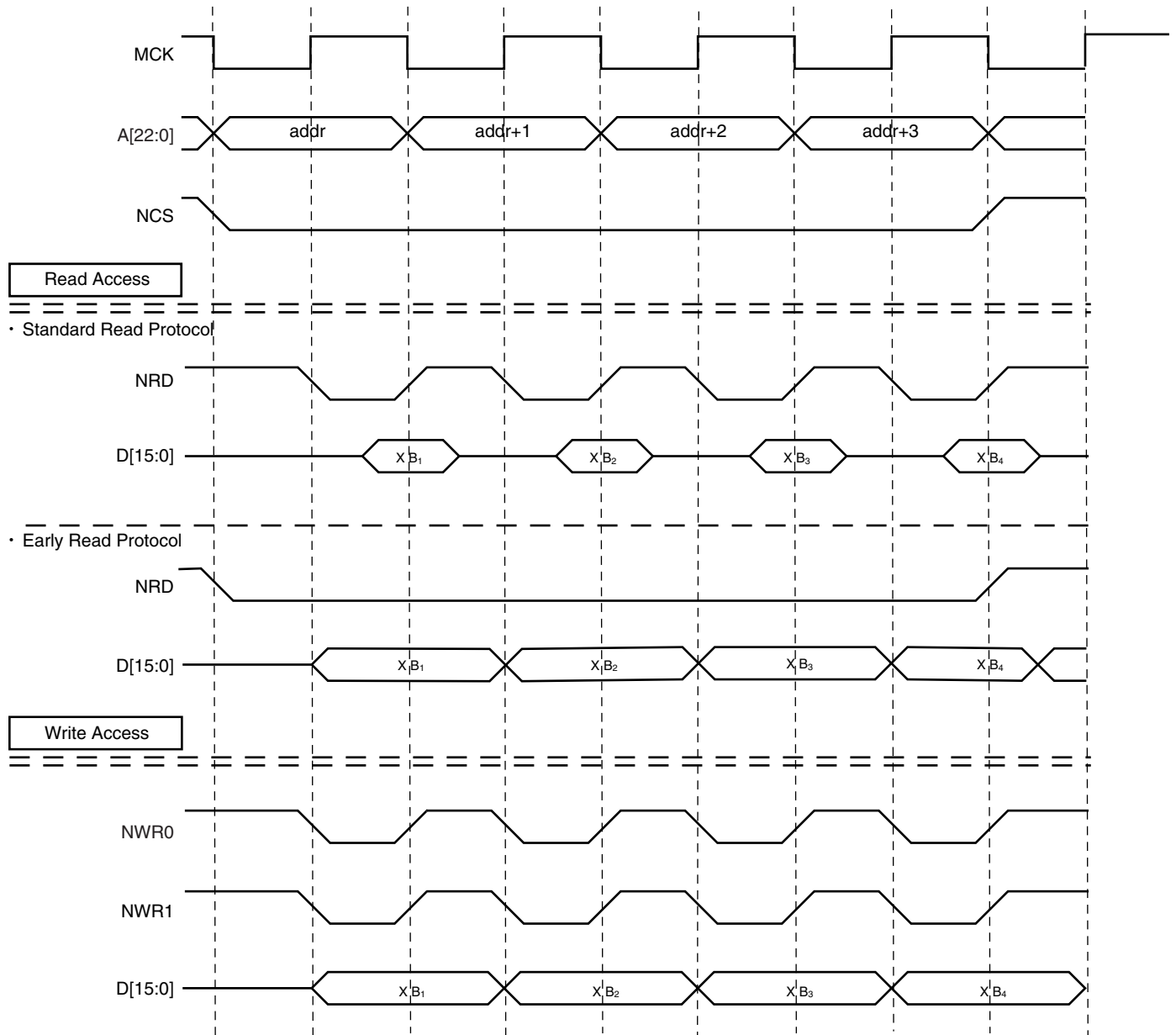

Figure 18-42. 1 Wait State, 8-bit Bus Width, Half-Word Transfer

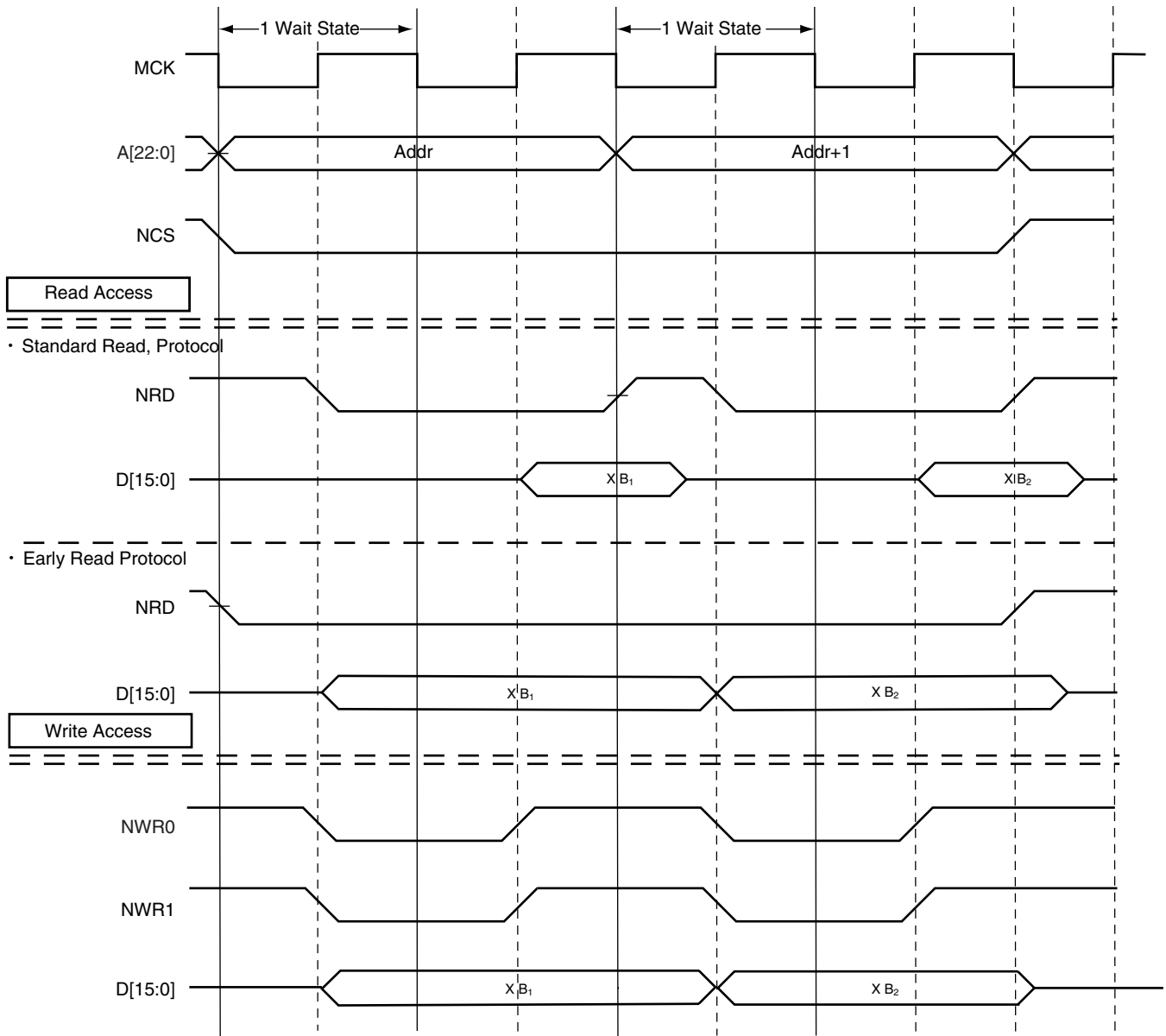

Figure 18-43. 1 Wait State, 8-bit Bus Width, Byte Transfer

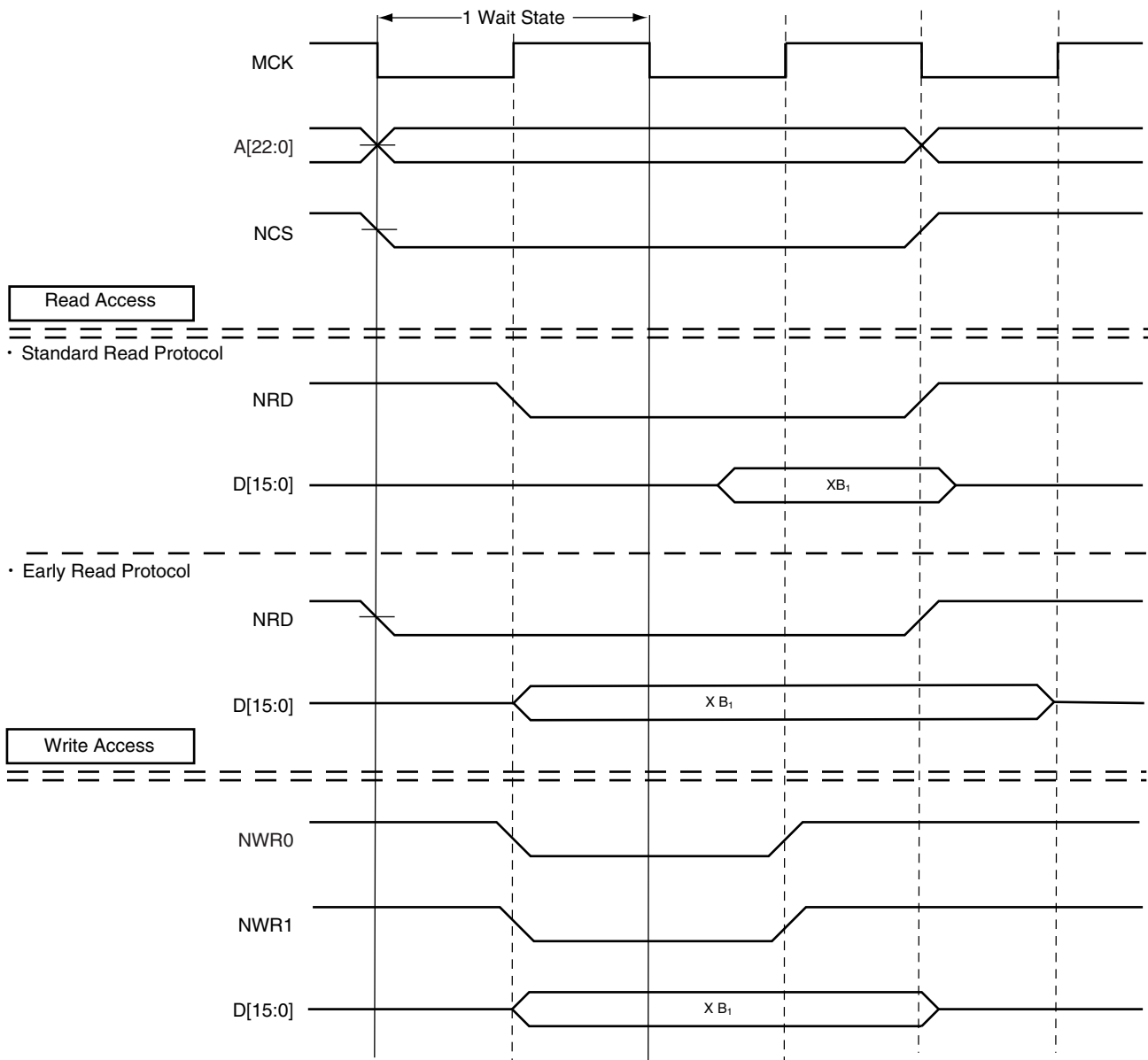
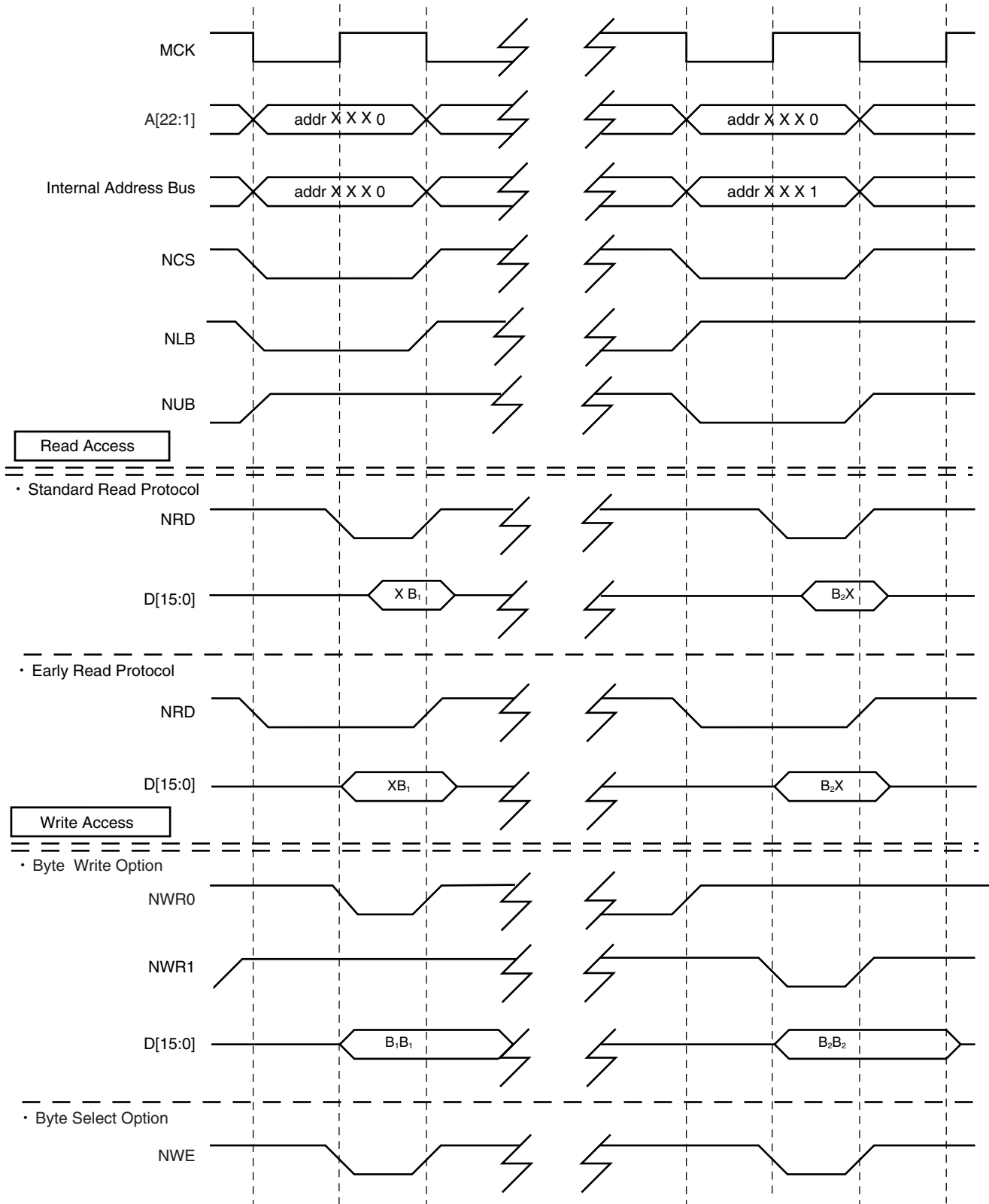

Figure 18-44. 0 Wait State, 16-bit Bus Width, Byte Transfer



18.7 Static Memory Controller (SMC) User Interface

The Static Memory Controller is programmed using the registers listed in [Table 18-4](#). Eight Chip Select Registers (SMC_CSR0 to SMC_CSR7) are used to program the parameters for the individual external memories.

Table 18-4. Register Mapping

Offset	Register	Name	Access	Reset
0x00	SMC Chip Select Register 0	SMC_CSR0	Read-write	0x00002000
0x04	SMC Chip Select Register 1	SMC_CSR1	Read-write	0x00002000
0x08	SMC Chip Select Register 2	SMC_CSR2	Read-write	0x00002000
0x0C	SMC Chip Select Register 3	SMC_CSR3	Read-write	0x00002000
0x10	SMC Chip Select Register 4	SMC_CSR4	Read-write	0x00002000
0x14	SMC Chip Select Register 5	SMC_CSR5	Read-write	0x00002000
0x18	SMC Chip Select Register 6	SMC_CSR6	Read-write	0x00002000
0x1C	SMC Chip Select Register 7	SMC_CSR7	Read-write	0x00002000

18.7.1 SMC Chip Select Registers

Register Name: SMC_CSR0..SMC_CSR7

Access Type: Read-write

Reset Value: See [Table 18-4 on page 189](#)

31	30	29	28	27	26	25	24
–	RWHOLD			–	RWSETUP		
23	22	21	20	19	18	17	16
–	–	–	–	–	–	ACSS	
15	14	13	12	11	10	9	8
DRP	DBW		BAT	TDF			
7	6	5	4	3	2	1	0
WSEN	NWS						

- **NWS: Number of Wait States**

This field defines the Read and Write signal pulse length from 1 cycle up to 128 cycles.

Note: When WSEN is 0, NWS will be read to 0 whichever the previous programmed value should be.

Number of Wait States	NWS Field	NRD Pulse Length Standard Read Protocol	NRD Pulse Length Early Read Protocol	NWR Pulse Length
0 ⁽¹⁾	Don't Care	½ cycle	1 cycle	½ cycle
1	0	1 + ½ cycles	2 cycles	1 cycle
2	1	2 + ½ cycles	3 cycles	2 cycles
X + 1	Up to X = 127	X + 1 + ½ cycles	X + 2 cycles	X + 1 cycle

Note: 1. Assuming WSEN Field = 0.

- **WSEN: Wait State Enable**

0: Wait states are disabled.

1: Wait states are enabled.

- **TDF: Data Float Time**

The external bus is marked occupied and cannot be used by another chip select during TDF cycles. Up to 15 cycles can be defined and represents the time allowed for the data output to go to high impedance after the memory is disabled.

- **BAT: Byte Access Type**

This field is used only if DBW defines a 16-bit data bus.

0: Chip select line is connected to two 8-bit wide devices.

1: Chip select line is connected to a 16-bit wide device.

• **DBW: Data Bus Width**

DBW		Data Bus Width
0	0	Reserved
0	1	16-bit
1	0	8-bit
1	1	Reserved

• **DRP: Data Read Protocol**

0: Standard Read Protocol is used.

1: Early Read Protocol is used.

• **ACSS: Address to Chip Select Setup**

ACSS		Chip Select Waveform
0	0	Standard, asserted at the beginning of the access and deasserted at the end.
0	1	One cycle less at the beginning and the end of the access.
1	0	Two cycles less at the beginning and the end of the access.
1	1	Three cycles less at the beginning and the end of the access.

• **RWSETUP: Read and Write Signal Setup Time**

See definition and description below.

• **RWHOLD: Read and Write Signal Hold Time**

See definition and description below.

RWSETUP ^{(1) (5)}			NRD Setup	NWR Setup	RWHOLD ^{(1) (4) (5)}			NRD Hold	NWR Hold
0	0	0	½ cycle ⁽²⁾ or 0 cycles ⁽³⁾	½ cycle	0	0	0	0	½ cycle
0	0	1	1 + ½ cycles	1 + ½ cycles	0	0	1	1 cycles	1 cycle
0	1	0	2 + ½ cycles	2 + ½ cycles	0	1	0	2 cycles	2 cycles
0	1	1	3 + ½ cycles	3 + ½ cycles	0	1	1	3 cycles	3 cycles
1	0	0	4 + ½ cycles	4 + ½ cycles	1	0	0	4 cycles	4 cycles
1	0	1	5 + ½ cycles	5 + ½ cycles	1	0	1	5 cycles	5 cycles
1	1	0	6 + ½ cycles	6 + ½ cycles	1	1	0	6 cycles	6 cycles
1	1	1	7 + ½ cycles	7 + ½ cycles	1	1	1	7 cycles	7 cycles

Notes: 1. For a visual description, please refer to “Setup and Hold Cycles” on page 168 and the diagrams in Figure 18-45 and Figure 18-46 and Figure 18-47 on page 192.

2. In Standard Read Protocol.

3. In Early Read Protocol. (It is not possible to use the parameters RWSETUP or RWHOLD in this mode.)

4. When the ECC Controller is used, RWHOLD must be programmed to 1 at least.

5. If an attempt is made to program the setup parameter as not equal to zero and the hold parameter as equal to zero, with WSEN = 0 (0 standard wait state), the SMC does not operate correctly.

Figure 18-45. Read-write Setup

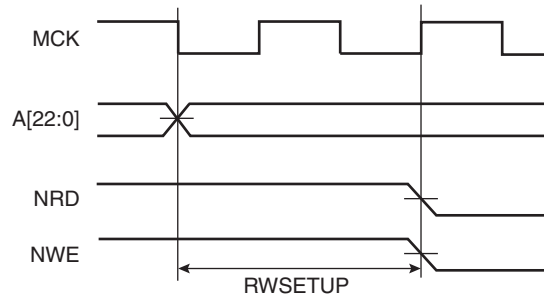

Figure 18-46. Read Hold

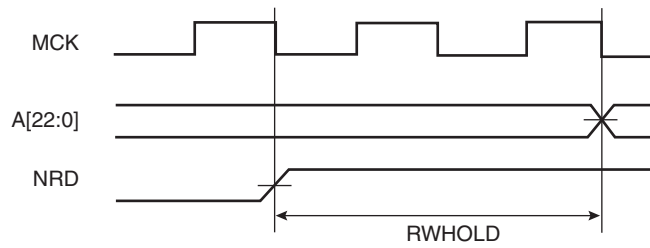
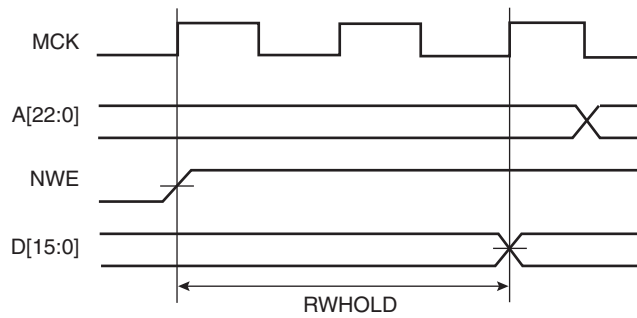

Figure 18-47. Write Hold



19. SDRAM Controller (SDRAMC)

19.1 Overview

The SDRAM Controller (SDRAMC) extends the memory capabilities of a chip by providing the interface to an external 16-bit or 32-bit SDRAM device. The page size supports ranges from 2048 to 8192 and the number of columns from 256 to 2048. It supports byte (8-bit), half-word (16-bit) and word (32-bit) accesses.

The SDRAM Controller supports a read or write burst length of one location. It does not support byte Read/Write bursts or half-word write bursts. It keeps track of the active row in each bank, thus maximizing SDRAM performance, e.g., the application may be placed in one bank and data in the other banks. So as to optimize performance, it is advisable to avoid accessing different rows in the same bank.

Features of the SDRAMC are:

- Numerous Configurations Supported
 - 2K, 4K, 8K Row Address Memory Parts
 - SDRAM with Two or Four Internal Banks
 - SDRAM with 16- or 32-bit Data Path
- Programming Facilities
 - Word, Half-word, Byte Access
 - Automatic Page Break When Memory Boundary Has Been Reached
 - Multibank Ping-pong Access
 - Timing Parameters Specified by Software
 - Automatic Refresh Operation, Refresh Rate is Programmable
- Energy-saving Capabilities
 - Self-refresh and Low-power Modes Supported
- Error Detection
 - Refresh Error Interrupt
- SDRAM Power-up Initialization by Software
- Latency is Set to Two Clocks (CAS Latency of 1, 3 Not Supported)
- Auto Precharge Command Not Used

19.2 Block Diagram

Figure 19-1. SDRAM Controller Block Diagram

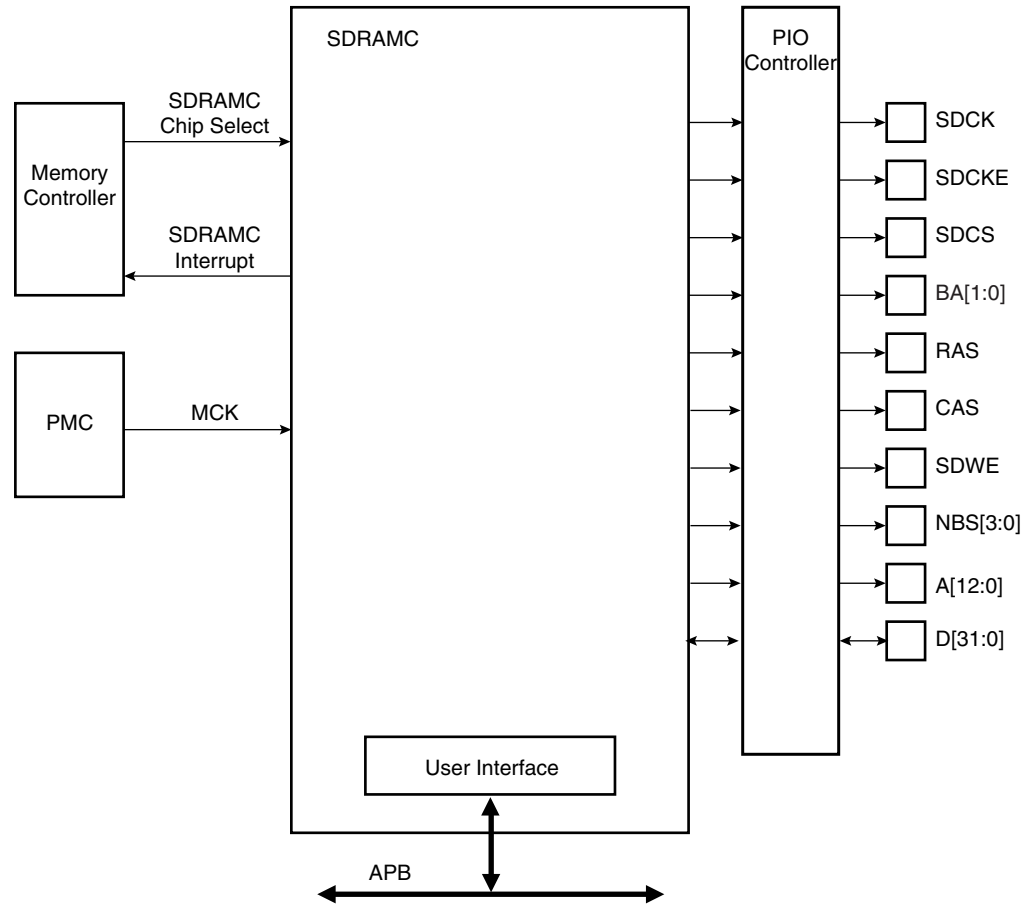

19.3 I/O Lines Description

Table 19-1. I/O Line Description

Name	Description	Type	Active Level
SDCK	SDRAM Clock	Output	
SDCKE	SDRAM Clock Enable	Output	High
SDCS	SDRAM Controller Chip Select	Output	Low
BA[1:0]	Bank Select Signals	Output	
RAS	Row Signal	Output	Low
CAS	Column Signal	Output	Low
SDWE	SDRAM Write Enable	Output	Low
NBS[3:0]	Data Mask Enable Signals	Output	Low
A[12:0]	Address Bus	Output	
D[31:0]	Data Bus	I/O	

19.4 Software Interface

The SDRAM Controller's function is to make the SDRAM device access protocol transparent to the user. Table 19-2 to Table 19-7 illustrate the SDRAM device memory mapping therefore seen by the user in correlation with the device structure. Various configurations are illustrated.

19.4.1 32-bit Memory Data Bus Width

Table 19-2. SDRAM Configuration Mapping: 2K Rows, 256/512/1024/2048 Columns

CPU Address Line																											
27	26	25	24	23	22	21	20	19	18	17	16	15	14	13	12	11	10	9	8	7	6	5	4	3	2	1	0
					Bk[1:0]				Row[10:0]								Column[7:0]							M[1:0]			
				Bk[1:0]		Row[10:0]								Column[8:0]							M[1:0]						
		Bk[1:0]		Row[10:0]								Column[9:0]							M[1:0]								
	Bk[1:0]		Row[10:0]								Column[10:0]							M[1:0]									

Table 19-3. SDRAM Configuration Mapping: 4K Rows, 256/512/1024/2048 Columns

CPU Address Line																											
27	26	25	24	23	22	21	20	19	18	17	16	15	14	13	12	11	10	9	8	7	6	5	4	3	2	1	0
				Bk[1:0]		Row[11:0]								Column[7:0]							M[1:0]						
		Bk[1:0]		Row[11:0]								Column[8:0]							M[1:0]								
	Bk[1:0]		Row[11:0]								Column[9:0]							M[1:0]									
	Bk[1:0]		Row[11:0]								Column[10:0]							M[1:0]									

Table 19-4. SDRAM Configuration Mapping: 8K Rows, 256/512/1024/2048 Columns

CPU Address Line																											
27	26	25	24	23	22	21	20	19	18	17	16	15	14	13	12	11	10	9	8	7	6	5	4	3	2	1	0
			Bk[1:0]		Row[12:0]								Column[7:0]							M[1:0]							
	Bk[1:0]		Row[12:0]								Column[8:0]							M[1:0]									
	Bk[1:0]		Row[12:0]								Column[9:0]							M[1:0]									
Bk[1:0]		Row[12:0]								Column[10:0]							M[1:0]										

- Notes:
1. M[1:0] is the byte address inside a 32-bit word.
 2. Bk[1] = BA1, Bk[0] = BA0.

19.4.2 16-bit Memory Data Bus Width

Table 19-5. SDRAM Configuration Mapping: 2K Rows, 256/512/1024/2048 Columns

CPU Address Line																											
27	26	25	24	23	22	21	20	19	18	17	16	15	14	13	12	11	10	9	8	7	6	5	4	3	2	1	0
						Bk[1:0]				Row[10:0]										Column[7:0]							M 0
						Bk[1:0]				Row[10:0]										Column[8:0]							M 0
					Bk[1:0]				Row[10:0]										Column[9:0]							M 0	
			Bk[1:0]				Row[10:0]										Column[10:0]							M 0			

Table 19-6. SDRAM Configuration Mapping: 4K Rows, 256/512/1024/2048 Columns

CPU Address Line																											
27	26	25	24	23	22	21	20	19	18	17	16	15	14	13	12	11	10	9	8	7	6	5	4	3	2	1	0
						Bk[1:0]				Row[11:0]										Column[7:0]							M 0
						Bk[1:0]				Row[11:0]										Column[8:0]							M 0
				Bk[1:0]				Row[11:0]										Column[9:0]							M 0		
		Bk[1:0]				Row[11:0]										Column[10:0]							M 0				

Table 19-7. SDRAM Configuration Mapping: 8K Rows, 256/512/1024/2048 Columns

CPU Address Line																											
27	26	25	24	23	22	21	20	19	18	17	16	15	14	13	12	11	10	9	8	7	6	5	4	3	2	1	0
						Bk[1:0]				Row[12:0]										Column[7:0]							M 0
				Bk[1:0]				Row[12:0]										Column[8:0]							M 0		
		Bk[1:0]				Row[12:0]										Column[9:0]							M 0				
	Bk[1:0]				Row[12:0]										Column[10:0]							M 0					

- Notes:
1. M0 is the byte address inside a 16-bit half-word.
 2. Bk[1] = BA1, Bk[0] = BA0.

19.5 Product Dependencies

19.5.1 SDRAM Device Initialization

The initialization sequence is generated by software. The SDRAM devices are initialized by the following sequence:

1. A minimum pause of 200 μ s is provided to precede any signal toggle.
2. An All Banks Precharge command is issued to the SDRAM devices.
3. Eight auto-refresh (CBR) cycles are provided.
4. A mode register set (MRS) cycle is issued to program the parameters of the SDRAM devices, in particular CAS latency and burst length.
5. A Normal Mode command is provided, 3 clocks after t_{MRD} is met.
6. Write refresh rate into the count field in the SDRAMC Refresh Timer register. (Refresh rate = delay between refresh cycles).

After these six steps, the SDRAM devices are fully functional.

The commands (NOP, MRS, CBR, normal mode) are generated by programming the command field in the SDRAMC Mode register

Figure 19-2. SDRAM Device Initialization Sequence

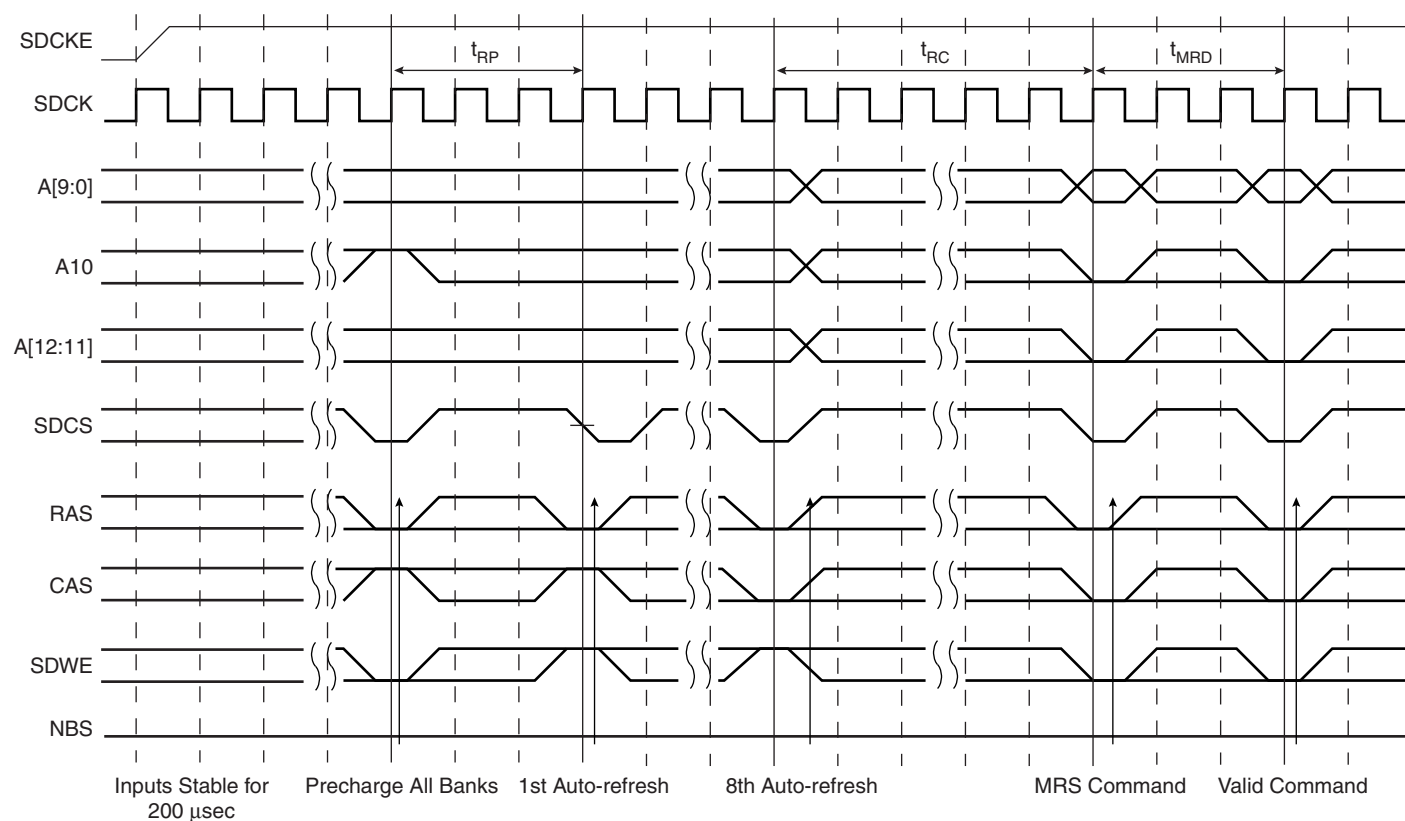

19.5.2 I/O Lines

The pins used for interfacing the SDRAM Controller may be multiplexed with the PIO lines. The programmer must first program the PIO controller to assign the SDRAM Controller pins to their peripheral function. If I/O lines of the SDRAM Controller are not used by the application, they can be used for other purposes by the PIO Controller.

19.5.3 Interrupt

The SDRAM Controller interrupt (Refresh Error notification) is connected to the Memory Controller. This interrupt may be ORed with other System Peripheral interrupt lines and is finally provided as the System Interrupt Source (Source 1) to the AIC (Advanced Interrupt Controller).

Using the SDRAM Controller interrupt requires the AIC to be programmed first.

19.6 Functional Description

19.6.1 SDRAM Controller Write Cycle

The SDRAM Controller allows burst access or single access. To initiate a burst access, the SDRAM Controller uses the transfer type signal provided by the master requesting the access. If the next access is a sequential write access, writing to the SDRAM device is carried out. If the next access is a write-sequential access, but the current access is to a boundary page, or if the next access is in another row, then the SDRAM Controller generates a precharge command, activates the new row and initiates a write command. To comply with SDRAM timing parameters, additional clock cycles are inserted between precharge/active (t_{RP}) commands and active/write (t_{RCD}) commands. For definition of these timing parameters, refer to the [Section 19.7.3 “SDRAMC Configuration Register” on page 208](#). This is described in [Figure 19-3](#) below.

Figure 19-3. Write Burst, 32-bit SDRAM Access

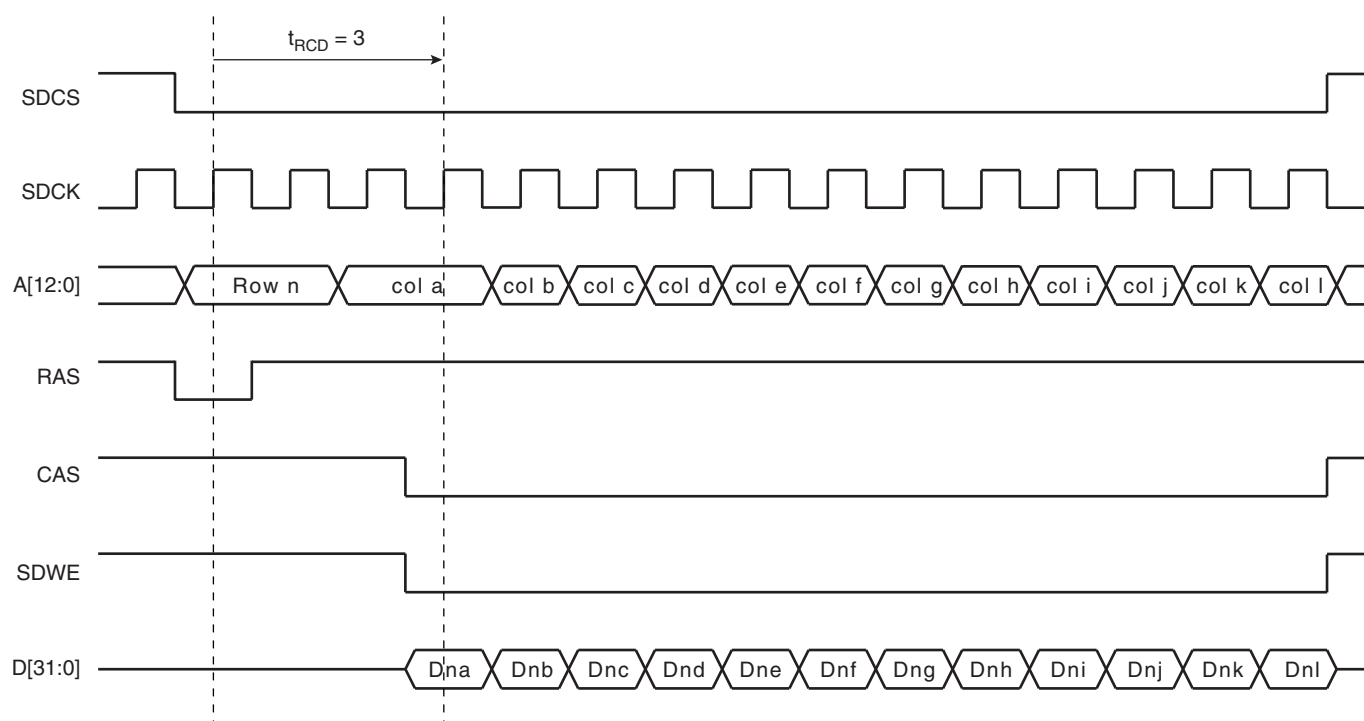

19.6.2 SDRAM Controller Read Cycle

The SDRAM Controller allows burst access or single access. To initiate a burst access, the SDRAM Controller uses the transfer type signal provided by the master requesting the access. If the next access is a sequential read access, reading to the SDRAM device is carried out. If the next access is a sequential read access, but the current access is to a boundary page, or if the next access is in another row, then the SDRAM Controller generates a precharge command, activates the new row and initiates a read command. To comply with SDRAM timing parameters, an additional clock cycle is inserted between the precharge/active (t_{RP}) command and the active/read (t_{RCD}) command. After a read command, additional wait states are generated to comply with cas latency. The SDRAM Controller supports a cas latency of two. For definition of these timing parameters, refer to [19.7.3 “SDRAMC Configuration Register” on page 208](#). This is described in [Figure 19-4](#) below.

Figure 19-4. Read Burst, 32-bit SDRAM access

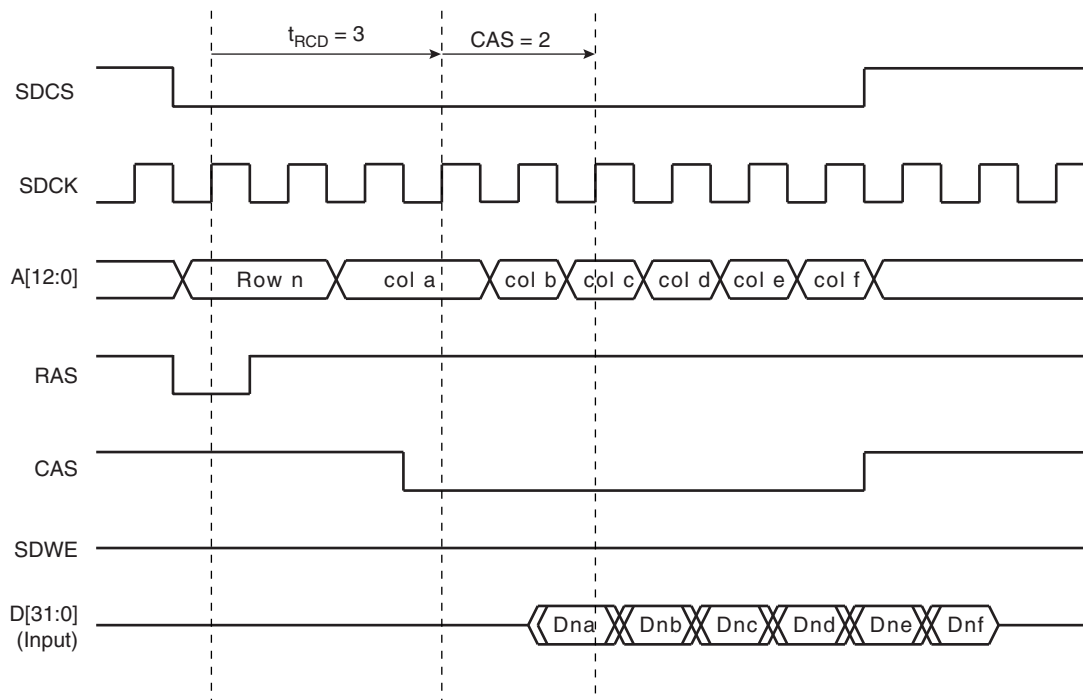

19.6.3 Border Management

When the memory row boundary has been reached, an automatic page break is inserted. In this case, the SDRAM controller generates a precharge command, activates the new row and initiates a read or write command. To comply with SDRAM timing parameters, an additional clock cycle is inserted between the precharge/active (t_{RP}) command and the active/read (t_{RCD}) command. This is described in Figure 19-5 below.

Figure 19-5. Read Burst with Boundary Row Access

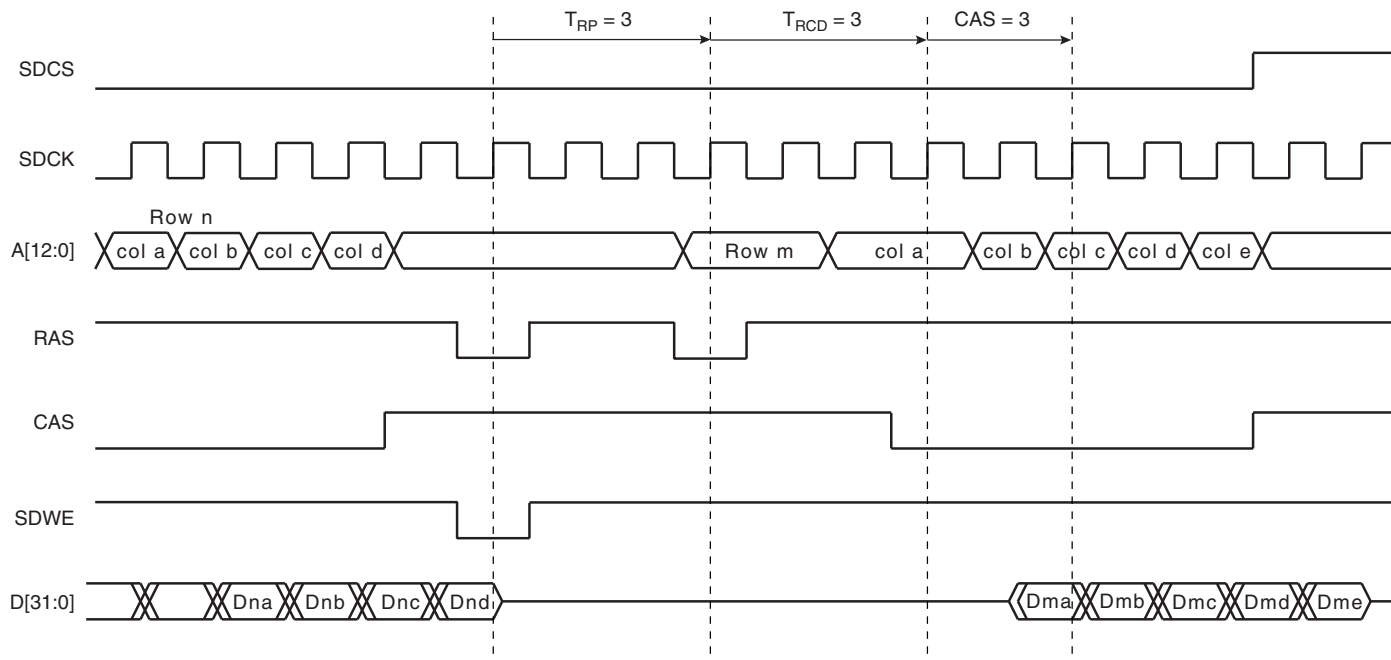

19.6.4 SDRAM Controller Refresh Cycles

An auto-refresh command is used to refresh the SDRAM device. Refresh addresses are generated internally by the SDRAM device and incremented after each auto-refresh automatically. The SDRAM Controller generates these auto-refresh commands periodically. A timer is loaded with the value in the register SDRAMC_TR that indicates the number of clock cycles between refresh cycles.

A refresh error interrupt is generated when the previous auto-refresh command did not perform. It will be acknowledged by reading the Interrupt Status Register (SDRAMC_ISR).

When the SDRAM Controller initiates a refresh of the SDRAM device, internal memory accesses are not delayed. However, if the CPU tries to access the SDRAM, the slave will indicate that the device is busy and the ARM BWAIT signal will be asserted. See [Figure 19-6](#) below.

Figure 19-6. Refresh Cycle Followed by a Read Access

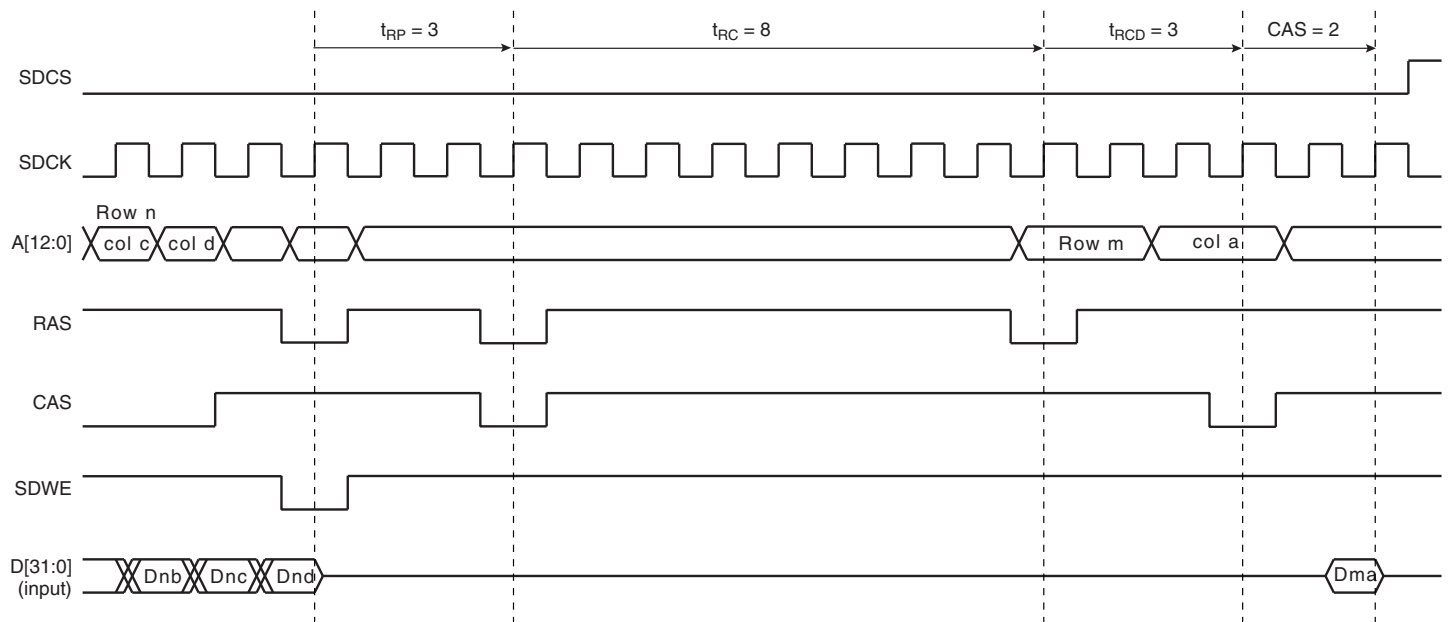

19.6.5 Power Management

19.6.5.1 Self-refresh Mode

Self-refresh mode is used in power-down mode, i.e., when no access to the SDRAM device is possible. In this case, power consumption is very low. The mode is activated by programming the self-refresh command bit (SRCB) in SDRAMC_SRR. In self-refresh mode, the SDRAM device retains data without external clocking and provides its own internal clocking, thus performing its own auto-refresh cycles. All the inputs to the SDRAM device become “don’t care” except SDCKE, which remains low. As soon as the SDRAM device is selected, the SDRAM Controller provides a sequence of commands and exits self-refresh mode, so the self-refresh command bit is disabled.

To re-activate this mode, the self-refresh command bit must be re-programmed.

The SDRAM device must remain in self-refresh mode for a minimum period of t_{RAS} and may remain in self-refresh mode for an indefinite period. This is described in [Figure 19-7](#) below.

Figure 19-7. Self-refresh Mode Behavior

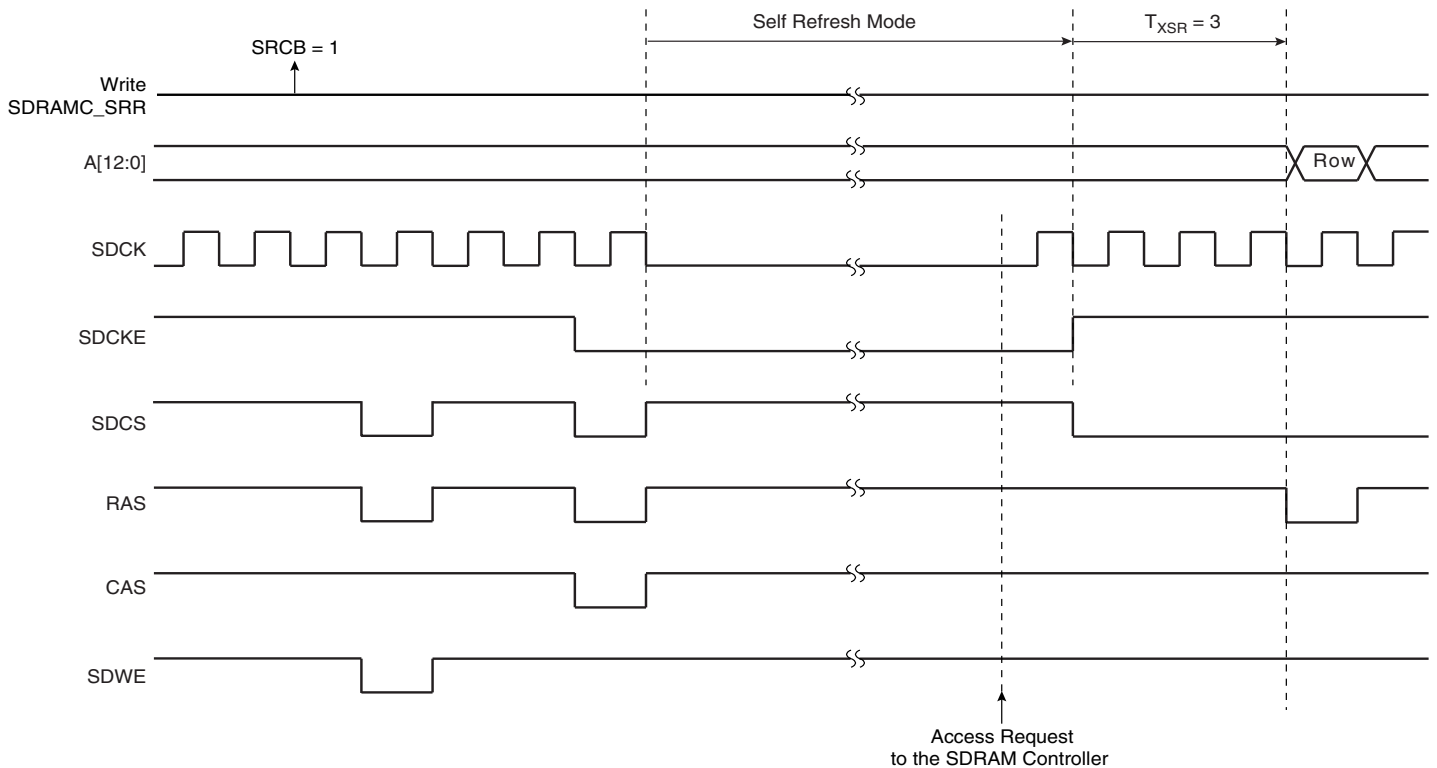

19.6.5.2 Low-power Mode

Low-power mode is used in power-down mode, i.e., when no access to the SDRAM device is possible. In this mode, power consumption is greater than in self-refresh mode. This state is similar to normal mode (No low-power mode/No self-refresh mode), but the SDCKE pin is low and the input and output buffers are deactivated as soon as the SDRAM device is no longer accessible. In contrast to self-refresh mode, the SDRAM device cannot remain in low-power mode longer than the refresh period (64 ms for a whole device refresh operation). As no auto-refresh operations are performed in this mode, the SDRAM Controller carries out the refresh operation. In order to exit low-power mode, a NOP command is required. The exit procedure is faster than in self-refresh mode.

When self-refresh mode is enabled, it is recommended to avoid enabling low-power mode. When low-power mode is enabled, it is recommended to avoid enabling self-refresh mode.

This is described in [Figure 19-8](#) below.

Figure 19-8. Low-power Mode Behavior

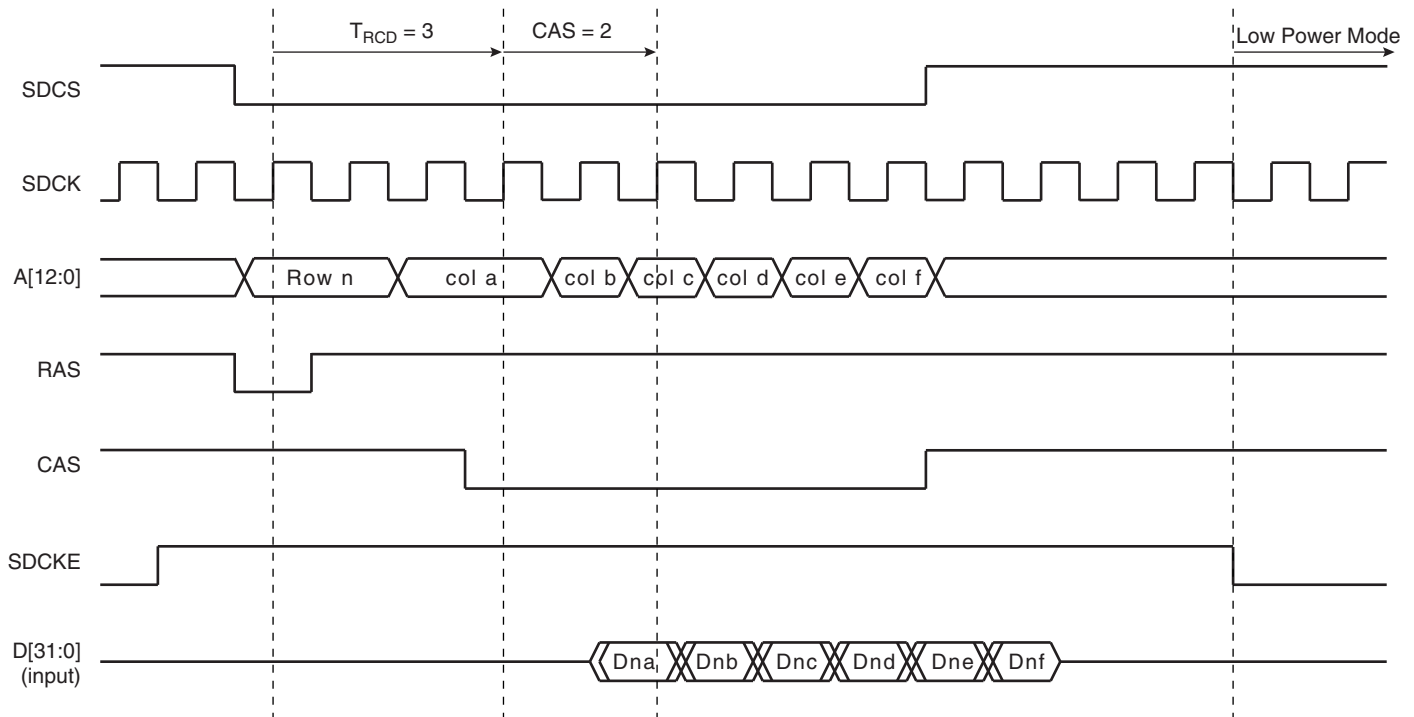

19.7 SDRAM Controller (SDRAMC) User Interface

Table 19-8. SDRAM Controller Memory Map

Offset	Register	Name	Access	Reset State
0x00	SDRAMC Mode Register	SDRAMC_MR	Read/Write	0x00000010
0x04	SDRAMC Refresh Timer Register	SDRAMC_TR	Read/Write	0x00000800
0x08	SDRAMC Configuration Register	SDRAMC_CR	Read/Write	0x2A99C140
0x0C	SDRAMC Self Refresh Register	SDRAMC_SRR	Write-only	–
0x10	SDRAMC Low Power Register	SDRAMC_LPR	Read/Write	0x0
0x14	SDRAMC Interrupt Enable Register	SDRAMC_IER	Write-only	–
0x18	SDRAMC Interrupt Disable Register	SDRAMC_IDR	Write-only	–
0x1C	SDRAMC Interrupt Mask Register	SDRAMC_IMR	Read-only	0x0
0x20	SDRAMC Interrupt Status Register	SDRAMC_ISR	Read-only	0x0



19.7.1 SDRAMC Mode Register

Register Name: SDRAMC_MR

Access Type: Read/Write

Reset Value: 0x00000010

31	30	29	28	27	26	25	24	
–	–	–	–	–	–	–	–	
23	22	21	20	19	18	17	16	
–	–	–	–	–	–	–	–	
15	14	13	12	11	10	9	8	
–	–	–	–	–	–	–	–	
7	6	5	4	3	2	1	0	
–	–	–	DBW	MODE				

• **MODE: SDRAMC Command Mode**

This field defines the command issued by the SDRAM Controller when the SDRAM device is accessed.

MODE				Description
0	0	0	0	Normal mode. Any access to the SDRAM is decoded normally.
0	0	0	1	The SDRAM Controller issues a NOP command when the SDRAM device is accessed regardless of the cycle.
0	0	1	0	The SDRAM Controller issues an “All Banks Precharge” command when the SDRAM device is accessed regardless of the cycle.
0	0	1	1	The SDRAM Controller issues a “Load Mode Register” command when the SDRAM device is accessed regardless of the cycle. The address offset with respect to the SDRAM device base address is used to program the Mode Register. For instance, when this mode is activated, an access to the “SDRAM_Base + offset” address generates a “Load Mode Register” command with the value “offset” written to the SDRAM device Mode Register.
0	1	0	0	The SDRAM Controller issues a “Refresh” Command when the SDRAM device is accessed regardless of the cycle. Previously, an “All Banks Precharge” command must be issued.

• **DBW: Data Bus Width**

0: Data bus width is 32 bits.

1: Data bus width is 16 bits.

19.7.2 SDRAMC Refresh Timer Register

Register Name: SDRAMC_TR

Access Type: Read/Write

Reset Value: 0x00000800

31	30	29	28	27	26	25	24
–	–	–	–	–	–	–	–
23	22	21	20	19	18	17	16
–	–	–	–	–	–	–	–
15	14	13	12	11	10	9	8
–	–	–	–	COUNT			
7	6	5	4	3	2	1	0
COUNT							

- **COUNT: SDRAMC Refresh Timer Count**

This 12-bit field is loaded into a timer that generates the refresh pulse. Each time the refresh pulse is generated, a refresh burst is initiated. The value to be loaded depends on the SDRAMC clock frequency (MCK: Master Clock), the refresh rate of the SDRAM device and the refresh burst length where 15.6 μ s per row is a typical value for a burst of length one.

To refresh the SDRAM device even if the reset value is not equal to 0, this 12-bit field must be written. If this condition is not satisfied, no refresh command is issued and no refresh of the SDRAM device is carried out.

19.7.3 SDRAMC Configuration Register

Register Name: SDRAMC_CR

Access Type: Read/Write

Reset Value: 0x2A99C140

31	30	29	28	27	26	25	24
-		TXSR				TRAS	
23	22	21	20	19	18	17	16
TRAS		TRCD				TRP	
15	14	13	12	11	10	9	8
TRP		TRC				TWR	
7	6	5	4	3	2	1	0
TWR		CAS		NB	NR		NC

- **NC: Number of Column Bits**

Reset value is 8 column bits.

NC		Column Bits
0	0	8
0	1	9
1	0	10
1	1	11

- **NR: Number of Row Bits**

Reset value is 11 row bits.

NR		Row Bits
0	0	11
0	1	12
1	0	13
1	1	Reserved

- **NB: Number of Banks**

Reset value is two banks.

NB		Number of Banks
0		2
1		4

- **CAS: CAS Latency**

Reset value is two cycles.

In the SDRAMC, only a CAS latency of two cycles is managed. In any case, another value must be programmed.

CAS		CAS Latency (Cycles)
0	0	Reserved
0	1	Reserved
1	0	2
1	1	Reserved

- **TWR: Write Recovery Delay**

Reset value is two cycles.

This field defines the Write Recovery Time in number of cycles. Number of cycles is between 2 and 15.

If TWR is less than or equal to 2, two clock periods are inserted by default.

- **TRC: Row Cycle Delay**

Reset value is eight cycles.

This field defines the delay between a Refresh and an Activate Command in number of cycles. Number of cycles is between 2 and 15.

If TRC is less than or equal to 2, two clock periods are inserted by default.

- **TRP: Row Precharge Delay**

Reset value is three cycles.

This field defines the delay between a Precharge Command and another Command in number of cycles. Number of cycles is between 2 and 15.

If TRP is less than or equal to 2, two clock periods are inserted by default.

- **TRCD: Row to Column Delay**

Reset value is three cycles.

This field defines the delay between an Activate Command and a Read/Write Command in number of cycles. Number of cycles is between 2 and 15.

If TRCD is less than or equal to 2, two clock periods are inserted by default.

- **TRAS: Active to Precharge Delay**

Reset value is five cycles.

This field defines the delay between an Activate Command and a Precharge Command in number of cycles. Number of cycles is between 2 and 15.

If TRAS is less than or equal to 2, two clock periods are inserted by default.

- **TXSR: Exit Self Refresh to Active Delay**

Reset value is five cycles.

This field defines the delay between SCKE set high and an Activate Command in number of cycles. Number of cycles is between 1/2 and 15.5.

If TXSR is equal to 0, 1/2 clock period is inserted by default.

19.7.4 SDRAMC Self-refresh Register

Register Name: SDRAMC_SRR

Access Type: Write-only

31	30	29	28	27	26	25	24
–	–	–	–	–	–	–	–
23	22	21	20	19	18	17	16
–	–	–	–	–	–	–	–
15	14	13	12	11	10	9	8
–	–	–	–	–	–	–	–
7	6	5	4	3	2	1	0
–	–	–	–	–	–	–	SRCB

• **SRCB: Self-refresh Command Bit**

0: No effect.

1: The SDRAM Controller issues a self-refresh command to the SDRAM device, the SDCK clock is inactivated and the SDCKE signal is set low. The SDRAM device leaves self-refresh mode when accessed again.

19.7.5 SDRAMC Low-power Register

Register Name: SDRAMC_LPR

Access Type: Read/Write

Reset Value: 0x0

31	30	29	28	27	26	25	24
–	–	–	–	–	–	–	–
23	22	21	20	19	18	17	16
–	–	–	–	–	–	–	–
15	14	13	12	11	10	9	8
–	–	–	–	–	–	–	–
7	6	5	4	3	2	1	0
–	–	–	–	–	–	–	LPCB

• **LPCB: Low-power Command Bit**

0: The SDRAM Controller low-power feature is inhibited: no low-power command is issued to the SDRAM device.

1: The SDRAM Controller issues a low-power command to the SDRAM device after each burst access, the SDCKE signal is set low. The SDRAM device will leave low-power mode when accessed and enter it after the access.

19.7.6 SDRAMC Interrupt Enable Register

Register Name: SDRAMC_IER

Access Type: Write-only

31	30	29	28	27	26	25	24
–	–	–	–	–	–	–	–
23	22	21	20	19	18	17	16
–	–	–	–	–	–	–	–
15	14	13	12	11	10	9	8
–	–	–	–	–	–	–	–
7	6	5	4	3	2	1	0
–	–	–	–	–	–	–	RES

- **RES: Refresh Error Status**

0: No effect.

1: Enables the refresh error interrupt.

19.7.7 SDRAMC Interrupt Disable Register

Register Name: SDRAMC_IDR

Access Type: Write-only

31	30	29	28	27	26	25	24
–	–	–	–	–	–	–	–
23	22	21	20	19	18	17	16
–	–	–	–	–	–	–	–
15	14	13	12	11	10	9	8
–	–	–	–	–	–	–	–
7	6	5	4	3	2	1	0
–	–	–	–	–	–	–	RES

- **RES: Refresh Error Status**

0: No effect.

1: Disables the refresh error interrupt.

19.7.8 SDRAMC Interrupt Mask Register

Register Name: SDRAMC_IMR

Access Type: Read-only

31	30	29	28	27	26	25	24
–	–	–	–	–	–	–	–
23	22	21	20	19	18	17	16
–	–	–	–	–	–	–	–
15	14	13	12	11	10	9	8
–	–	–	–	–	–	–	–
7	6	5	4	3	2	1	0
–	–	–	–	–	–	–	RES

- **RES: Refresh Error Status**

0: The refresh error interrupt is disabled.

1: The refresh error interrupt is enabled.

19.7.9 SDRAMC Interrupt Status Register

Register Name: SDRAMC_ISR

Access Type: Read-only

31	30	29	28	27	26	25	24
–	–	–	–	–	–	–	–
23	22	21	20	19	18	17	16
–	–	–	–	–	–	–	–
15	14	13	12	11	10	9	8
–	–	–	–	–	–	–	–
7	6	5	4	3	2	1	0
–	–	–	–	–	–	–	RES

- **RES: Refresh Error Status**

0: No refresh error has been detected since the register was last read.

1: A refresh error has been detected since the register was last read.

20. Burst Flash Controller (BFC)

20.1 Overview

The Burst Flash Controller (BFC) provides an interface for external 16-bit Burst Flash devices and handles an address space of 256M bytes. It supports byte, half-word and word aligned accesses and can access up to 32M bytes of Burst Flash devices. The BFC also supports data bus and address bus multiplexing. The Burst Flash interface supports only continuous burst reads. Programmable burst lengths of four or eight words are not possible. The BFC never generates an abort signal, regardless of the requested address within the 256M bytes of address space.

The BFC can operate with two burst read protocols depending on whether or not the address increment of the Burst Flash device is signal controlled. The Burst Flash Controller Mode Register (BFC_MR) located in the BFC user interface is used in programming Asynchronous or Burst Operating Modes. In Burst Mode, the read protocol, Clock Controlled Address Advance, automatically increments the address at each clock cycle. Whereas in Signal Controlled Address Advance protocol the address is incremented only when the Burst Address Advance signal is active. When Address and Data Bus Multiplexing Mode is chosen, the sixteen lowest address bits are multiplexed with the data bus.

The BFC clock speed is programmable to be either master clock or master clock divided by 2 or 4. Page size handling (16 bytes to 1024 bytes) is required by some Burst Flash devices unable to handle continuous burst read. The number of latency cycles after address valid goes up to sixteen cycles. The number of latency cycles after output enable runs between one and three cycles. The Burst Flash Controller can also be programmed to suspend and maintain the current burst. This attribute gives other devices the possibility to share the BFC busses without any loss of efficiency. In Burst Mode, the BFC can restart a sequential access without any additional latency.

Features of the Burst Flash Controller are:

- Multiple Access Modes Supported
 - Asynchronous or Burst Mode Byte, Half-word or Word Read Accesses
 - Asynchronous Mode Half-word Write Accesses
- Adaptability to Different Device Speed Grades
 - Programmable Burst Flash Clock Rate
 - Programmable Data Access Time
 - Programmable Latency after Output Enable
- Adaptability to Different Device Access Protocols and Bus Interfaces
 - Two Burst Read Protocols: Clock Control Address Advance or Signal Controlled Address Advance
 - Multiplexed or Separate Address and Data Busses
 - Continuous Burst and Page Mode Accesses Supported

20.2 Block Diagram

Figure 20-1. Burst Flash Controller Block Diagram

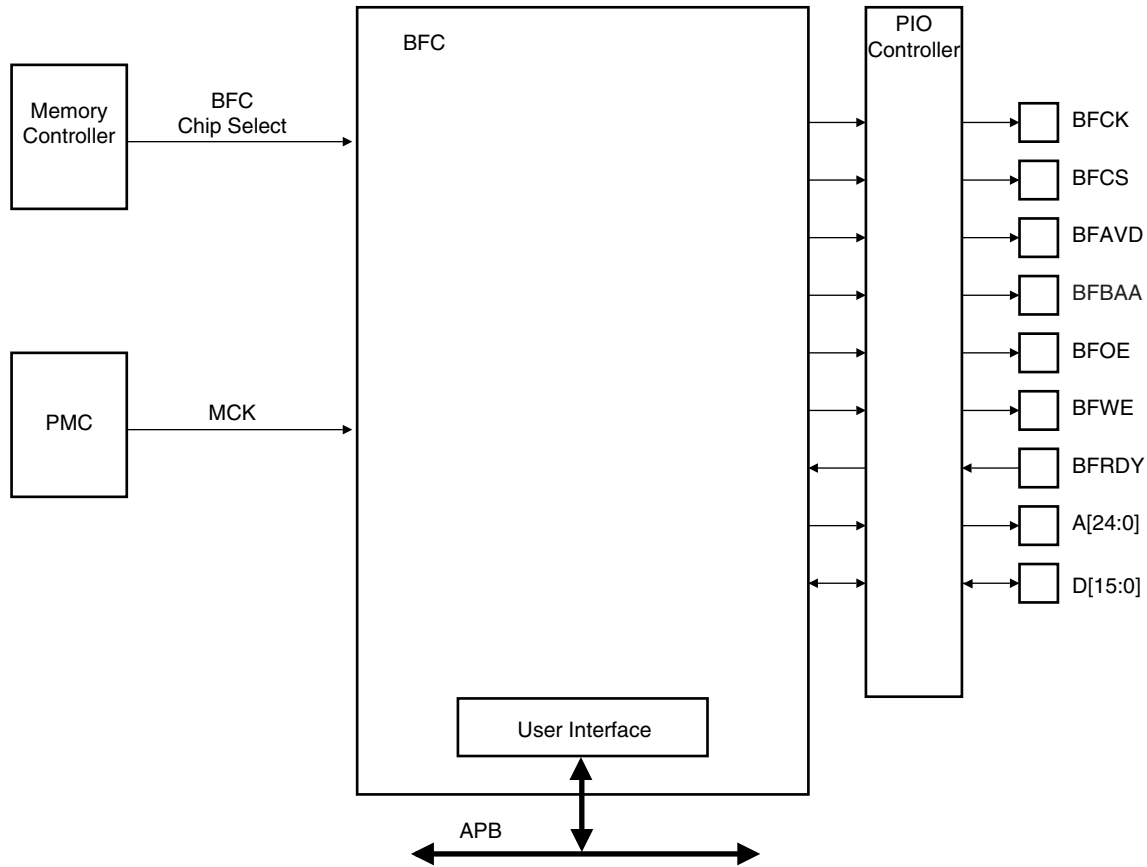

20.3 I/O Lines Description

Table 20-1. I/O Lines Description

Name	Description	Type	Active Level
BFCK	Burst Flash Clock	Output	
BFCS	Burst Flash Chip Select	Output	Low
BFAVD	Burst Flash Address Valid	Output	Low
BFBAA	Burst Flash Address Advance	Output	Low
BFOE	Burst Flash Output Enable	Output	Low
BFWE	Burst Flash Write Enable	Output	Low
BFRDY	Burst Flash Ready	Input	High
A[24:0]	Address Bus	Output	
D[15:0]	Data Bus	I/O	

20.4 Application Example

20.4.1 Burst Flash Interface

The Burst Flash Interface provides control, address and data signals to the Burst Flash Memory. These signals are detailed in [Section 20.6 "Functional Description" on page 218](#) which describes the BFC functionality and operating modes. [Figure 20-2](#) below presents an illustration of the possible connections of the BFC to some popular Burst Flash Memories.

Figure 20-2. Burst Flash Controller Connection Example

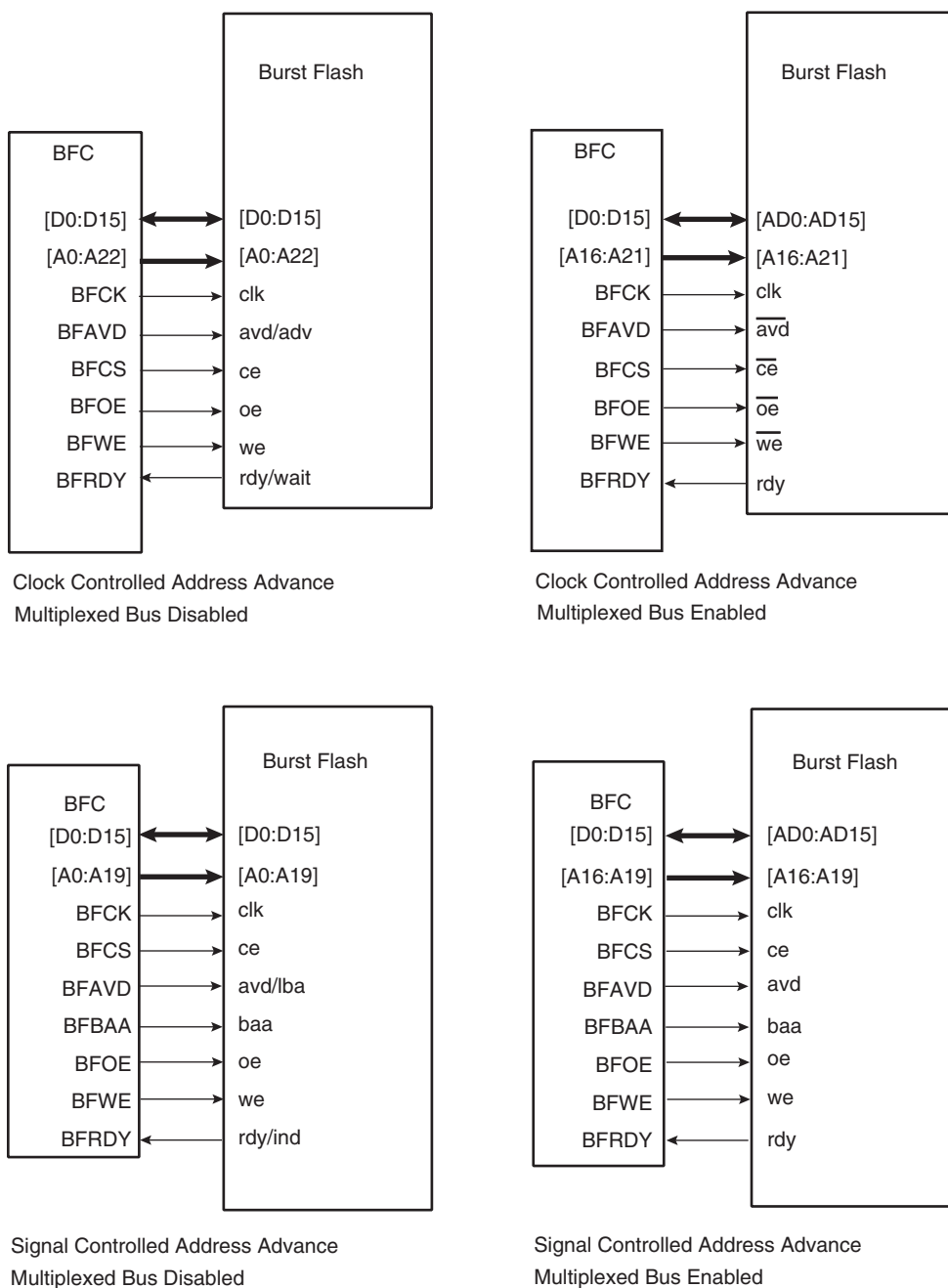

20.5 Product Dependencies

20.5.1 I/O Lines

The pins used for interfacing the Burst Flash Controller may be multiplexed with the PIO lines. The programmer must first program the PIO controller to assign the Burst Flash Controller pins to their peripheral function. If I/O lines of the Burst Flash Controller are not used by the application, they can be used for other purposes by the PIO Controller.

20.6 Functional Description

The Burst Flash Controller drives the following signals:

- Address Valid (BFAVD), to latch the addresses
- Clock (BFCK), to supply the burst clock
- Burst Advance Address (BFBA), to control the Burst Flash memory address advance when programmed to operate in signal controlled burst advance
- Write Enable (BFWE), to write to the Burst Flash device
- Output Enable (BFOE), to enable the external device data drive on the data bus

When enabled, the BFC also drives the address bus, the data bus and the Chip Select (BFCS) line. The Ready Signal (BFRDY) is taken as an input and used as an indicator for the next data availability.

20.6.1 Burst Flash Controller Reset State

After reset, the BFC is disabled and, therefore, must be enabled by programming the field BFCOM. See [“Burst Flash Controller Mode Register” on page 227](#). At this time, the Burst Flash Controller operates in Asynchronous Mode. The Burst Flash memory can be programmed by writing and reading in Asynchronous Mode.

20.6.2 Burst Flash Controller Clock Selection

The BFC clock rate is programmable to be either Master Clock, Master Clock divided by 2 or Master Clock divided by 4. The clock selection is necessary in Burst Mode as well as in Asynchronous Mode. The latency fields in the mode register and all burst Flash control signal waveforms are related to the Burst Flash Clock (BFCK) period.

The BFC clock rate is selected by the BFCC field. [“Burst Flash Controller Mode Register” on page 227](#)

Figure 20-3. Burst Flash Clock Rates

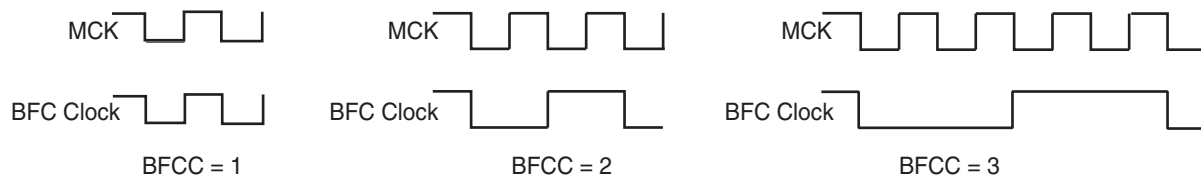

20.6.3 Burst Flash Controller Asynchronous Mode

In Asynchronous Mode, the Burst Flash Controller clock is off. The BFCK signal is driven low.

The BFC performs read access to bytes (8-bits), half-words (16-bits), and words (32-bits). In the last case, the BFC autonomously transforms the word read request into two separate half-word reads. This is fully transparent to the user.

The BFC performs only half-word write requests. Write requests for bytes or words are ignored by the BFC.

For any access in the address space, the address is driven on the address bus while a pulse is driven on the BFAVD signal (see [Figure 20-4 on page 220](#), and [Figure 20-5 on page 221](#)). The Burst Flash address is also driven on the data bus if the multiplexed data and address bus options are enabled. ([Figure 20-4 on page 220](#)).

- For write access, the signal BFWE is asserted in the following BFCK clock cycle.
- For read access, the signal BFOE is asserted one cycle later. This additional cycle in read accesses has been inserted to switch the I/O pad direction so as to avoid conflict on the Burst Flash data bus when address and data busses are multiplexed.

The Address Valid Latency (AVL) determines the length of the pulses as a number of Master Clock cycles. The AVL field [See “Burst Flash Controller Mode Register” on page 227](#). is coded as the Address Valid Latency minus 1. Waveforms in [Figure 20-4 on page 220](#) and [Figure 20-5 on page 221](#) show the AVL field definition in read and write accesses.

- In read access, the access finishes with the rising edge of BFOE.
- In write access, data and address lines are released one half cycle after the rising edge of BFWE.

After a read access to the Burst Flash, it takes Output Enable Latency (OEL) cycles for the Burst Flash device to release the data bus. The OEL field [See “Burst Flash Controller Mode Register” on page 227](#). gives the OEL expressed in BFCK Clock cycles. This prevents other memory controllers from using the Data Bus until it is released by the Burst Flash device.

In [Figure 20-4 on page 220](#) (multiplexed address and data busses), one idle cycle (OEL = 1) is inserted between the read and write accesses. The Burst Flash device must release the data bus before the BFC can drive the address. As shown in [Figure 20-5 on page 221](#), where busses are not multiplexed, the write access can start as soon as the read access ends. In the same way, the OEL has no impact when a read follows a write access.

Waveforms in [Figure 20-4 on page 220](#) below and [Figure 20-5 on page 221](#) are related to the Burst Flash Controller Clock even though the BFCK pin is driven low in Asynchronous Mode. The BFCC field [See “Burst Flash Controller Mode Register” on page 227](#). is used as a measure of the burst Flash speed and must also be programmed in Asynchronous Mode.

Figure 20-4. Asynchronous Read and Write Accesses with Multiplexed Address and Data Buses

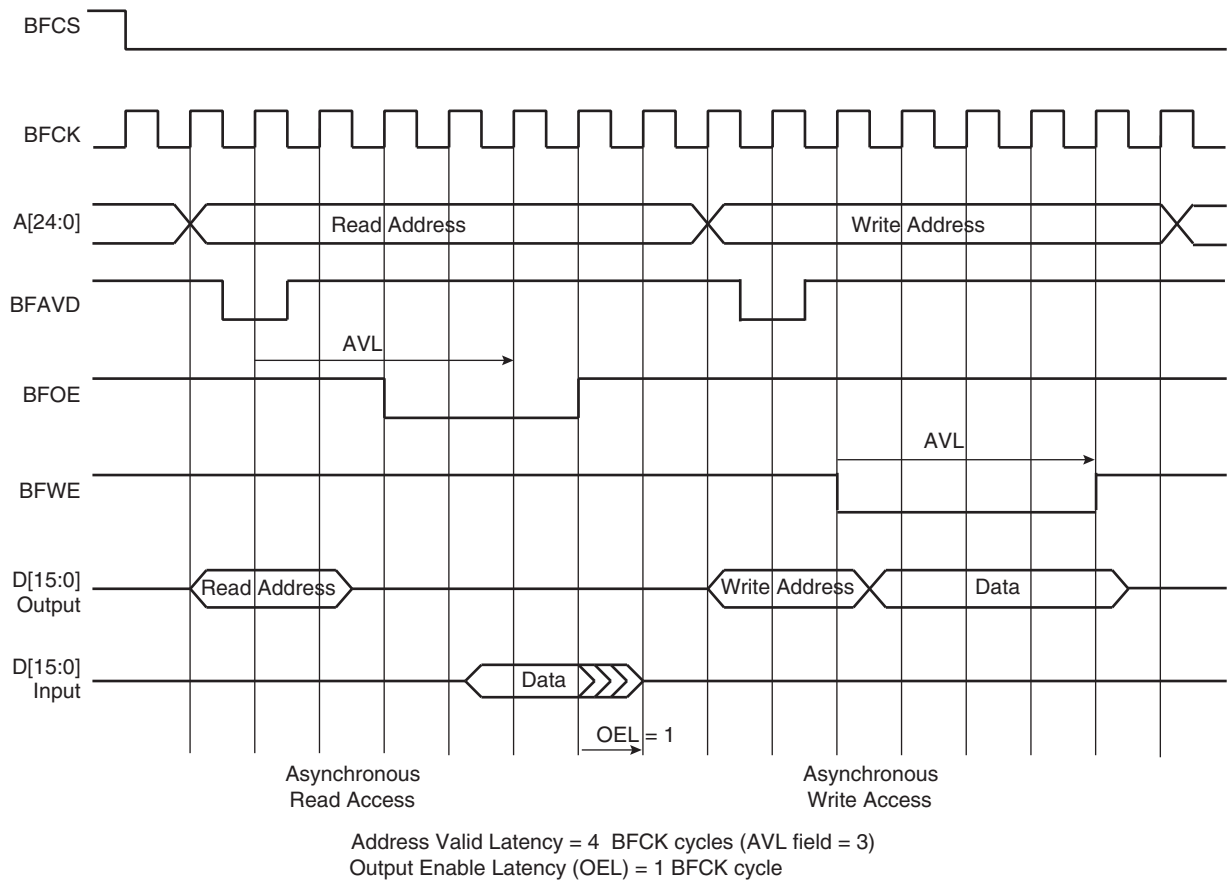
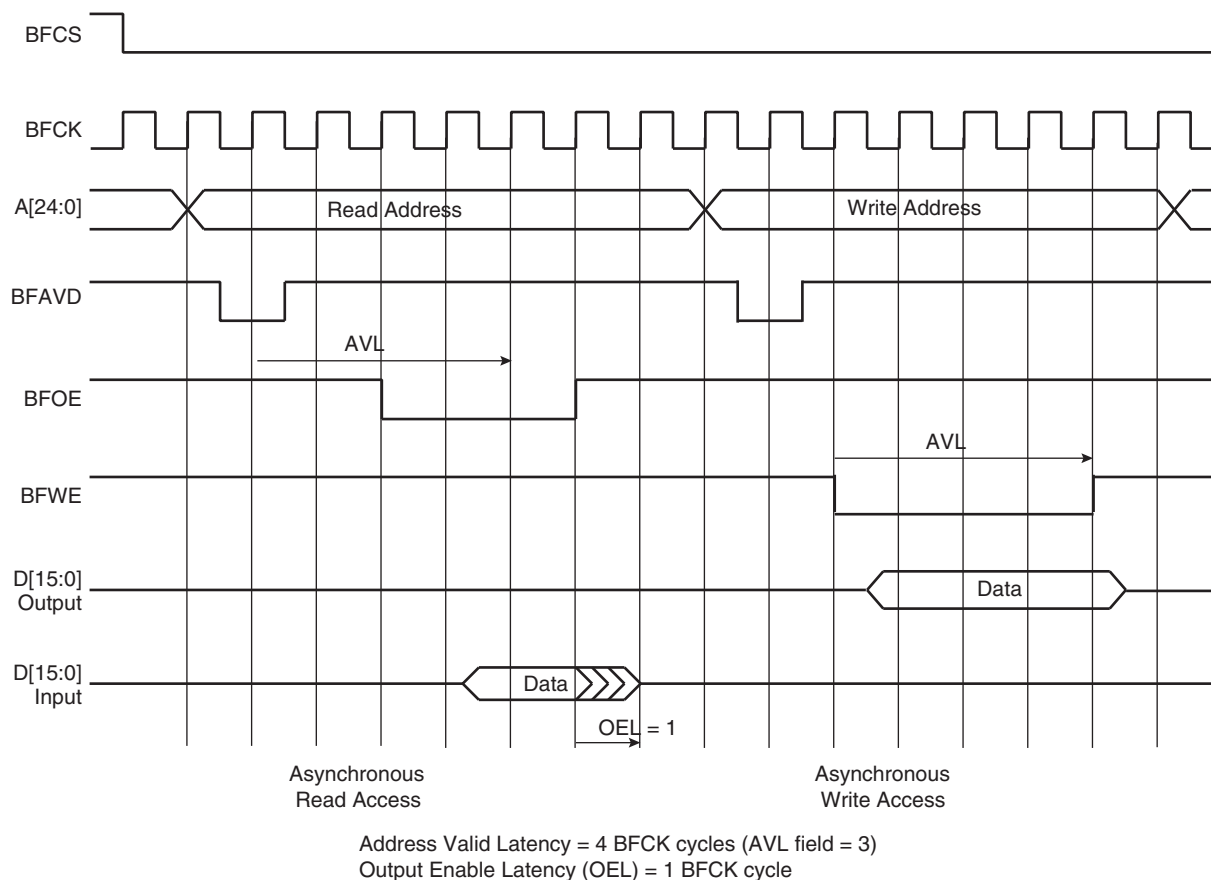

Figure 20-5. Asynchronous Read and Write Accesses with Non-multiplexed Address and Data



20.6.4 Burst Flash Controller Synchronous Mode

Writing the Burst Flash Controller Operating Mode field (BFCOM) to 2 See “[Burst Flash Controller Mode Register](#)” on page 227. puts the BFC in Burst Mode. The BFC Clock is driven on the BFCK pin. Only read accesses are treated and write accesses are ignored. The BFC supports read access of bytes, half-words or words.

20.6.4.1 Burst Read Protocols

The BFC supports two burst read protocols:

- Clock Controlled Address Advance, the internal address of the burst Flash is automatically incremented at each BFCK cycle.
- Signal Controlled Address Advance, the internal address of the burst Flash is incremented only when the BFBA signal is active.

20.6.4.2 Read Access in Burst Mode

When a read access is requested in Burst Mode, the requested address is registered in the BFC. For subsequent read accesses, the address is compared to the previous one. Then the two following cases are considered:

1. In case of a non-sequential access, the current burst is broken and the BFC launches a new burst by performing an address latch cycle. The address is presented on the address bus in any case and on the data bus if the multiplexed bus option is enabled.

This new address is registered in the BFC and is then used as reference for further accesses.

2. In case of sequential access, and provided that the BFOEH mode is selected in the mode register See “Burst Flash Controller Mode Register” on page 227., the internal burst address is incremented:
 - Through the BFBA pin, if the Signal Controlled Address Advance is enabled.
 - By enabling the clock during one clock cycle in Clock Controlled Address Advance Mode.

These protocols are illustrated in Figure 20-6 below and Figure 20-7 on page 223. The Address Valid Latency AVL+1 See “Burst Flash Controller Mode Register” on page 227. gives the number of cycles from the first rising clock edge when BFAVD is asserted to the rising edge that causes the read of data D1.

Note: This rising edge is also used to latch D0 in the BFC.

Figure 20-6. Burst Suspend and Resume with Signal Control Address Advance

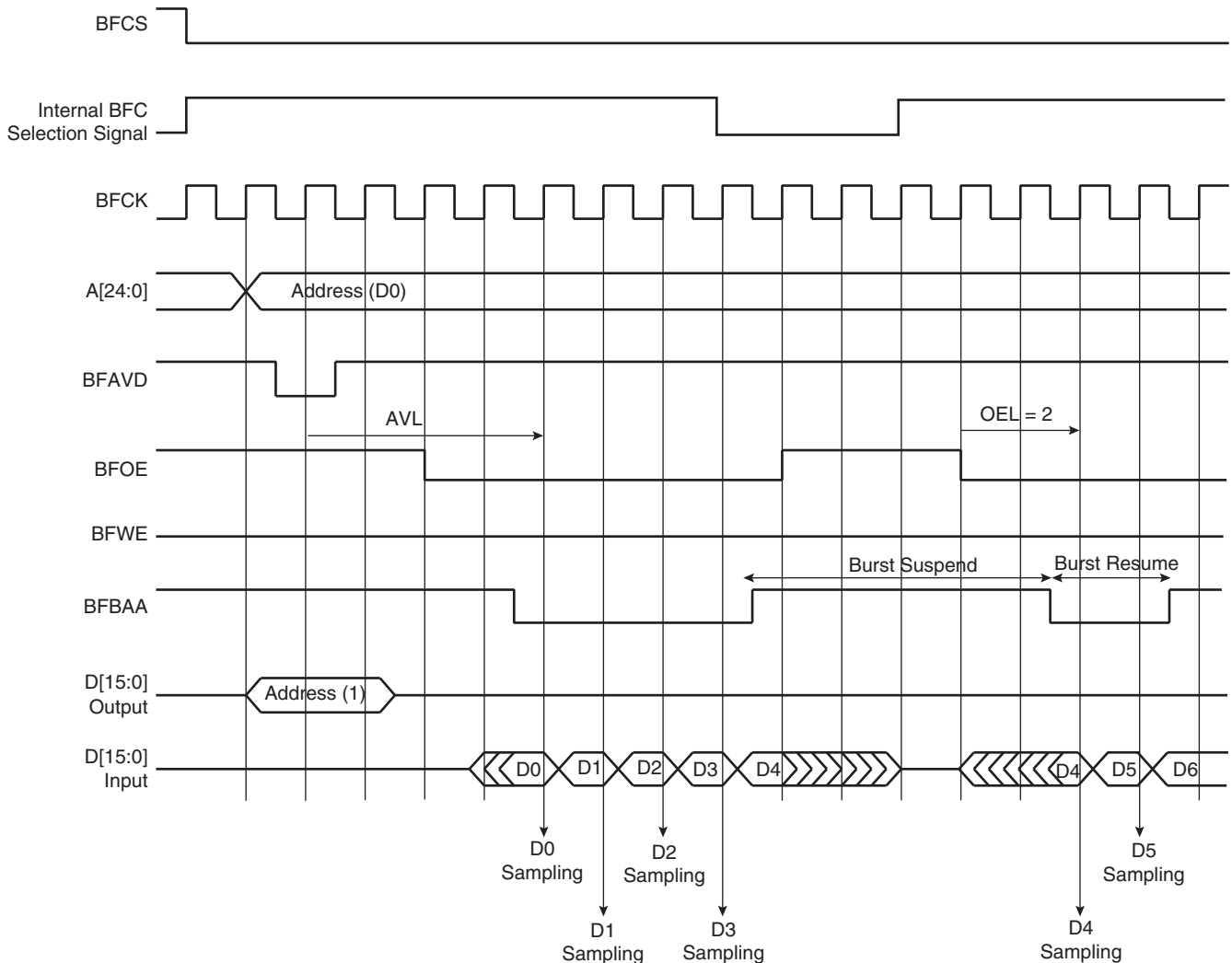

Burst Suspend and Resume (BFOEH = 1)
 Signal Control Address Advance (BAAEN = 1)
 (1) Only if Multiplexed Address & Data Buses

Address Valid Latency = 4 BFCK cycles (AVL field = 3)
 Output Enable Latency (OEL) = 2 BFCK cycles

Figure 20-7. Burst Suspend and Resume with Clock Control Address Advance

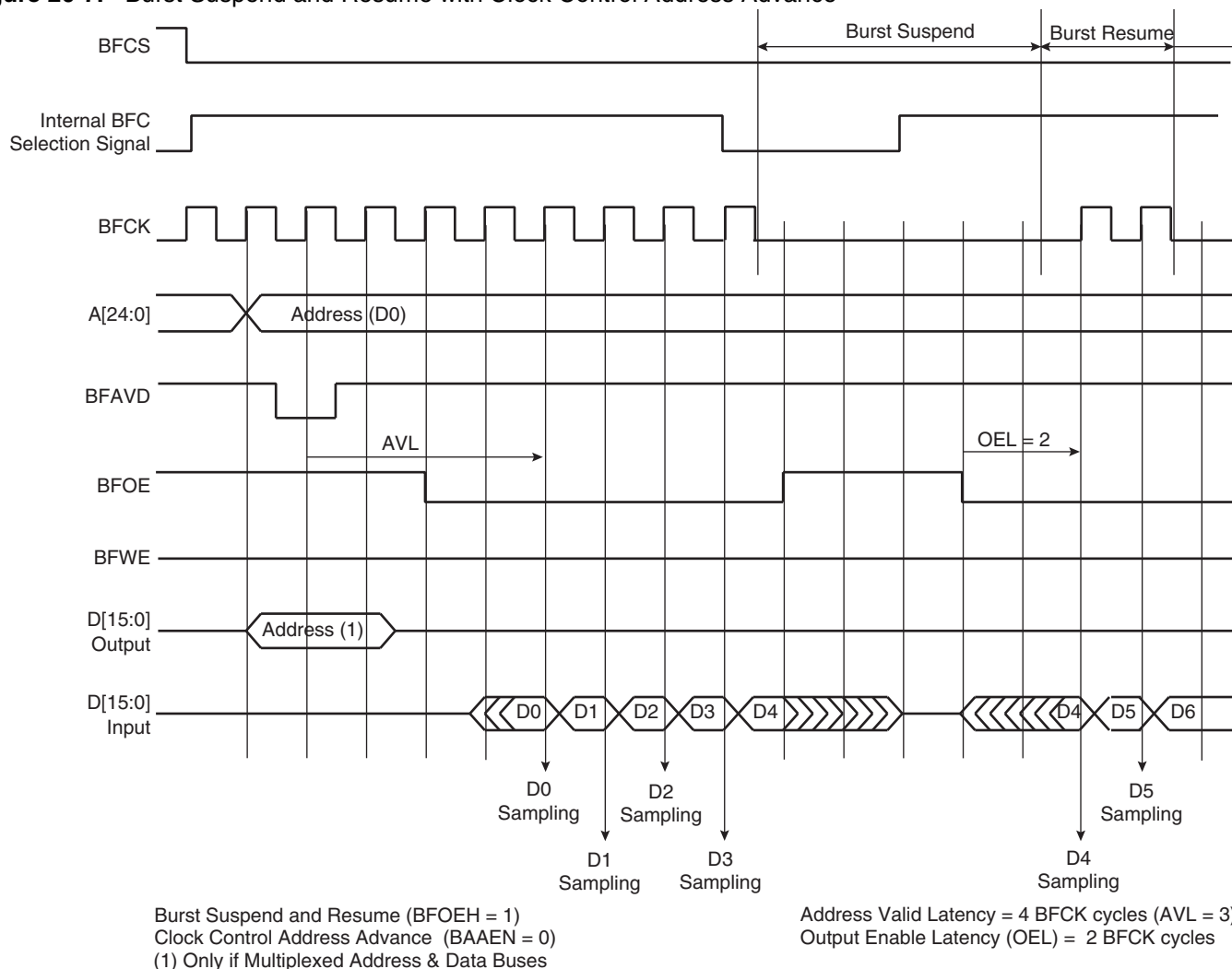

20.6.4.3 Burst Suspension for Transfer Enabling

The BFC can suspend a burst to enable other internal transfers, or other memory controllers to use the memory address and data busses if they are shared. Two modes are provided on the BFOEH bit (Burst Flash Output Enable Handling, See “Burst Flash Controller Mode Register” on page 227.):

- BFOEH = 1: the BFC suspends the burst when it is no longer selected and the BFOE pin is deasserted. When a new sequential access on the Burst Flash device is requested, the burst is resumed and the BFOE pin is asserted again. The data is available on the data bus after OEL cycles. This mode provides a minimal access latency. (Refer to Figure 20-6 on page 222 and Figure 20-7 above).
- BFOEH = 0: the BFC suspends the burst when it is no longer selected and the BFOE pin is deasserted. When a new access to the Burst Flash device is requested, either sequential or not, a new burst is initialized and the next data is available as defined by the AVL latency field in the Mode Register. This mode is provided for Burst Flash devices for which the deassertion of the BFOE signal causes an irreversible break of the burst. Figure 20-8 on page 224 shows the access request to the BFC and the deassertion of the BFOE signal due to a deselection

of the BFC (Suspend). When the BFC is requested again, a new burst is started even though the requested address is sequential to the previously requested address.

Figure 20-8. Burst Flash Controller with No Burst Enable Handling

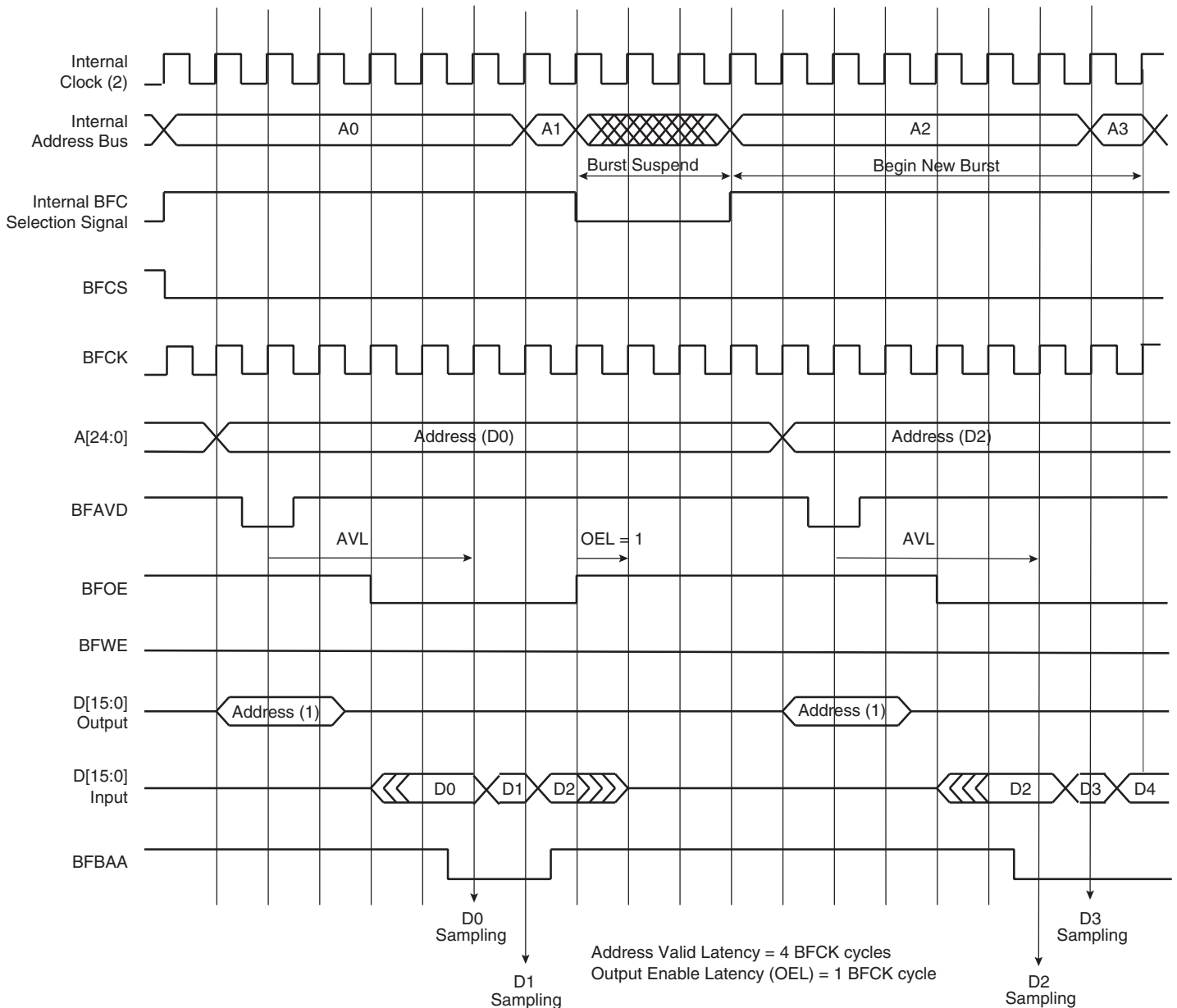

(1) Only if Multiplexed Address & Data Busses
 (2) Master Clock Mode (BFCC = 1)

No Burst Output Enable Handling (BFOEH = 0)
 Signal Control Advance Address (BAAEN = 1)

20.6.4.4 Continuous Burst Reads

The BFC performs continuous burst reads. It is also possible to program page sizes from 16 bytes up to 1024 bytes. This is done by setting the appropriate value in the PAGES field of the [“Burst Flash Controller Mode Register”](#) on page 227.

Page Mode

In Page Mode, the BFC stops the current burst and starts a new burst each time the requested address matches a page boundary. [Figure 20-9 on page 225](#) illustrates a 16-byte page size. Data D0 to D10 belong to two separate pages and are accessed through two burst accesses. This mode is provided for Burst Flash devices that cannot handle continuous burst read (in which case, a continuous burst access to address D0 would cause the Burst Flash internal address to wrap around address D0). Page Mode can be disabled by programming a null value in the PAGES field of the [“Burst Flash Controller Mode Register” on page 227](#).

Figure 20-9. Burst Read in Page Mode

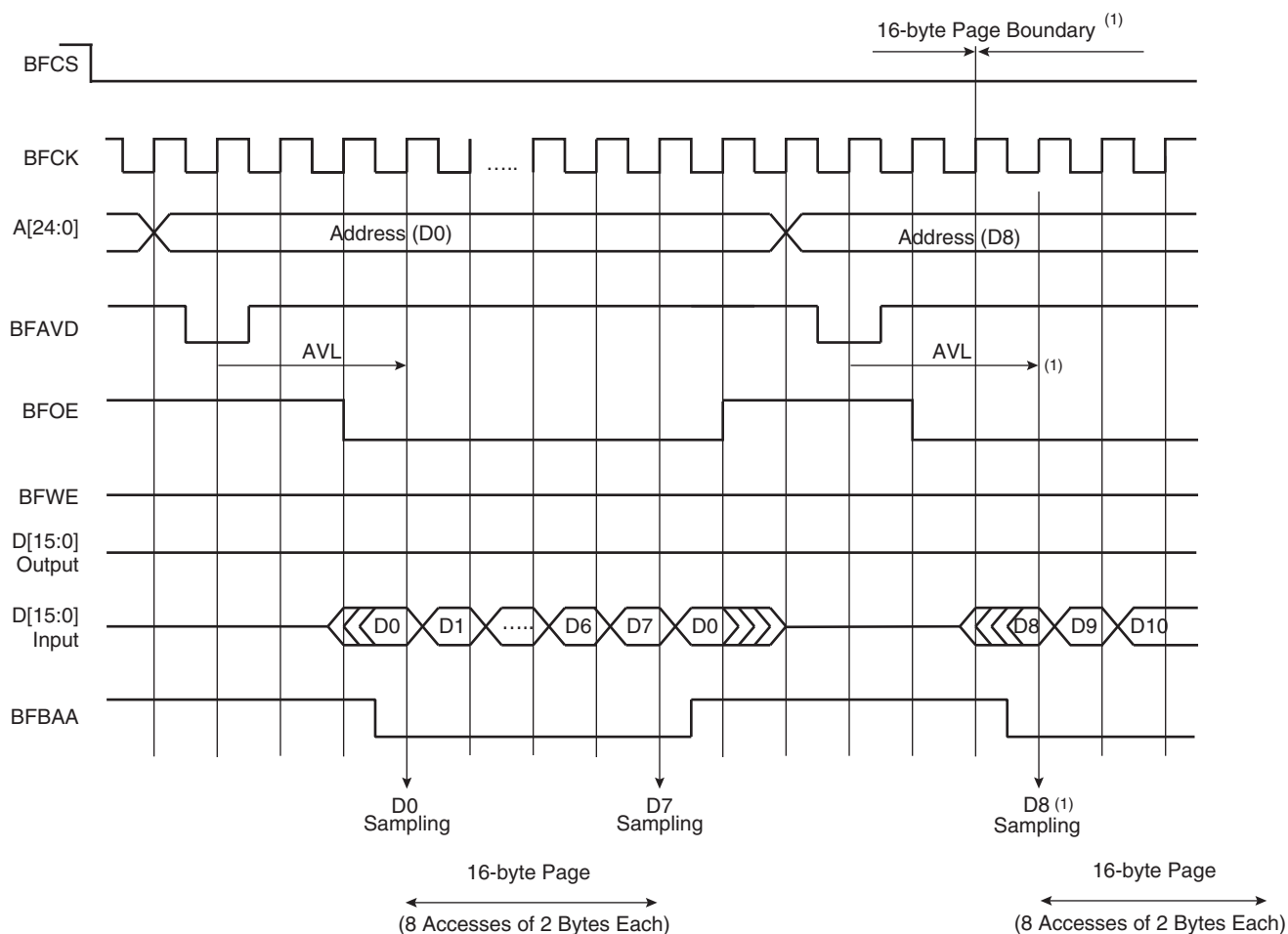

Burst Read in Page Mode (16 Bytes)
 Signal Control Advance Address (BAAEN = 1)
 (1) A New Page Begins at D8

Address Valid Latency = 3 BFCK cycles (AVL field = 2)
 Output Enable Latency (OEL) = 1 BFCK cycle
 Page Size = 16 Bytes

Ready Enable Mode

In Ready Enable Mode (bit RDYEN in the [“Burst Flash Controller Mode Register” on page 227](#)), the BFC uses the Ready Signal (BFRDY) from the burst Flash device as an indicator of the next data availability. The BFRDY signal must be asserted one BFCK cycle before data is valid. In [Figure 20-10 on page 226](#) below, the BFRDY signal indicates on edge (A) that the expected D4 data will not be available on the next rising BFCK edge. The BFRDY signal remains low until rising at edge (B). D4 is then sampled on edge (C).

When the RDYEN mode is disabled (RDYEN = 0), the BFRDY signal at the BFC input interface is ignored. This mode is provided for Burst Flash devices that do not handle the BFRDY signal.

Figure 20-10. Burst Read Using BFRDY Signal

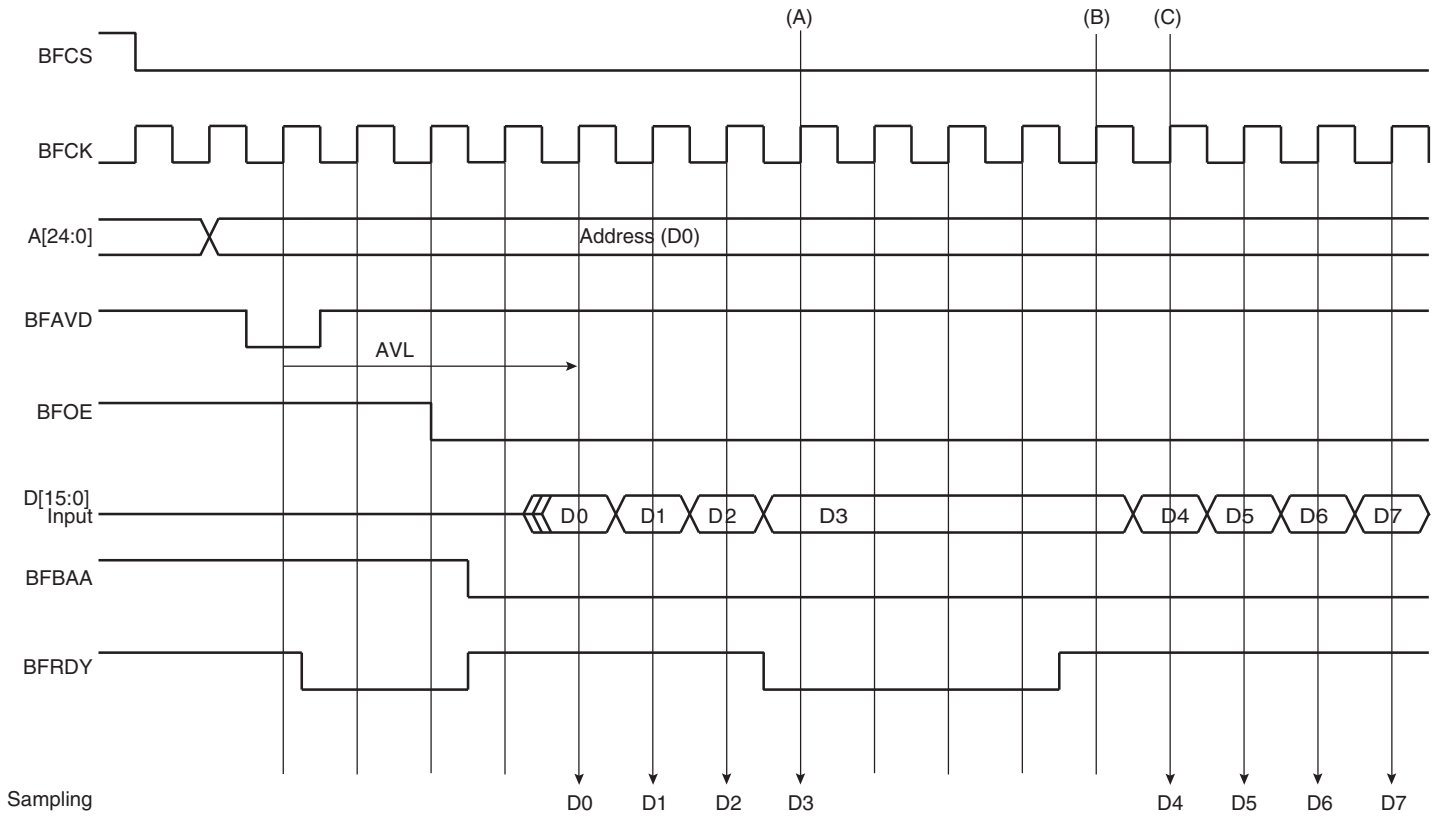

Burst Read
Signal Control Advance Address (BAAEN = 1)

Address Valid Latency = 4 BFCK cycles (AVL field = 3)
Output Enable Latency (OEL) = 1 BFCK cycle

20.7 Burst Flash Controller (BFC) User Interface

20.7.1 Burst Flash Controller Mode Register

Register Name: BFC_MR

Access Type: Read/Write

Reset Value: :0x0

31	30	29	28	27	26	25	24
–	–	–	–	–	–	–	–
23	22	21	20	19	18	17	16
–	–	–	–	RDYEN	MUXEN	BFOEH	BAAEN
15	14	13	12	11	10	9	8
–	–	OEL			PAGES		
7	6	5	4	3	2	1	0
AVL				BFCC		BFCOM	

- **BFCOM: Burst Flash Controller Operating Mode**

BFCOM		BFC Operating Mode
0	0	Disabled.
0	1	Asynchronous
1	0	Burst Read
1	1	Reserved

- **BFCC: Burst Flash Controller Clock**

BFCC		BFC Clock
0	0	Reserved
0	1	Master Clock
1	0	Master Clock divided by 2
1	1	Master Clock divided by 4

- **AVL: Address Valid Latency**

The Address Valid Latency is defined as the number of BFC Clock Cycles from the first BFCK rising edge when BFAVD is asserted to the BFCK rising edge that samples read data. The Latency is equal to AVL + 1.

- **PAGES: Page Size**

This field defines the page size handling and the page size.

Pages			Page Size
0	0	0	No page handling. The Ready Signal (BFRDY) is sampled to check if the next data is available.
0	0	1	16 bytes page size
0	1	0	32 bytes page size
0	1	1	64 bytes page size
1	0	0	128 bytes page size
1	0	1	256 bytes page size
1	1	0	512 bytes page size
1	1	1	1024 bytes page size

- **OEL: Output Enable Latency**

This field defines the number of idle cycles inserted after each level change on the BFOE output enable signal. OEL range is 1 to 3.

- **BAAEN: Burst Address Advance Enable**

0: The burst clock is enabled to increment the burst address or, disabled to remain at the same address.

1: The burst clock is continuous and the burst address advance is controlled with the BFBAA pin.

- **BFOEH: Burst Flash Output Enable Handling**

0: No burst resume in Burst Mode. When the BFC is deselected, this causes an irreversible break of the burst. A new burst will be initiated for the next access.

1: Burst resume. When the BFC is deselected, the burst is suspended. It will be resumed if the next access is sequential to the last one.

- **MUXEN: Multiplexed Bus Enable**

0: The address and data busses operate independently.

1: The address and data busses are multiplexed. Actually, the address is presented on both the data bus and the address bus when the BFAVD signal is asserted.

- **RDYEN: Ready Enable Mode**

0: The BFRDY input signal at the BFC input interface is ignored.

1: The BFRDY input signal is used as an indicator of data availability in the next cycle.

21. Peripheral DMA Controller (PDC)

21.1 Overview

The Peripheral DMA Controller (PDC) transfers data between on-chip serial peripherals such as the UART, USART, SSC, SPI, MCI and the on- and off-chip memories. Using the Peripheral DMA Controller avoids processor intervention and removes the processor interrupt-handling overhead. This significantly reduces the number of clock cycles required for a data transfer and, as a result, improves the performance of the microcontroller and makes it more power efficient.

The PDC channels are implemented in pairs, each pair being dedicated to a particular peripheral. One channel in the pair is dedicated to the receiving channel and one to the transmitting channel of each UART, USART, SSC and SPI.

The user interface of a PDC channel is integrated in the memory space of each peripheral. It contains:

- A 32-bit memory pointer register
- A 16-bit transfer count register
- A 32-bit register for next memory pointer
- A 16-bit register for next transfer count

The peripheral triggers PDC transfers using transmit and receive signals. When the programmed data is transferred, an end of transfer interrupt is generated by the corresponding peripheral.

Important features of the PDC are:

- Generates Transfers to/from Peripherals Such as DBGU, USART, SSC, SPI and MCI
- Supports Up to Twenty Channels (Product Dependent)
- One Master Clock Cycle Needed for a Transfer from Memory to Peripheral
- Two Master Clock Cycles Needed for a Transfer from Peripheral to Memory

21.2 Block Diagram

Figure 21-1. Block Diagram

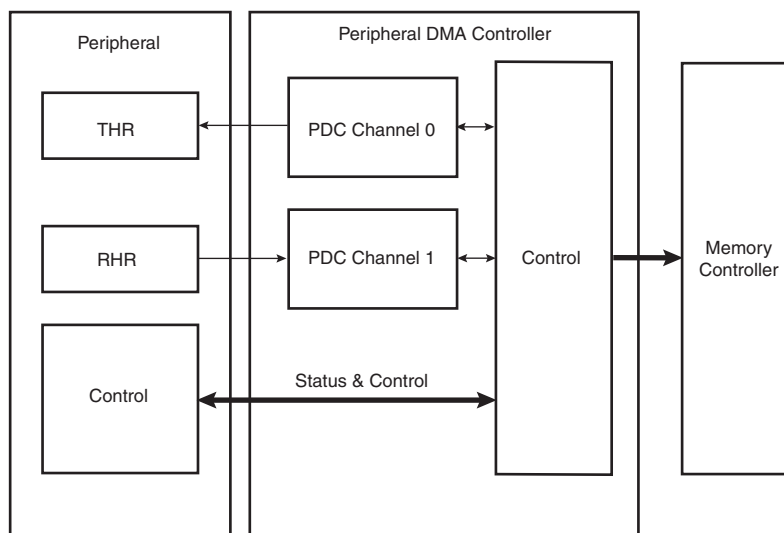

21.3 Functional Description

21.3.1 Configuration

The PDC channels user interface enables the user to configure and control the data transfers for each channel. The user interface of a PDC channel is integrated into the user interface of the peripheral (offset 0x100), which it is related to.

Per peripheral, it contains four 32-bit Pointer Registers (RPR, RNPR, TPR, and TNPR) and four 16-bit Counter Registers (RCR, RNCR, TCR, and TNCR).

The size of the buffer (number of transfers) is configured in an internal 16-bit transfer counter register, and it is possible, at any moment, to read the number of transfers left for each channel.

The memory base address is configured in a 32-bit memory pointer by defining the location of the first address to access in the memory. It is possible, at any moment, to read the location in memory of the next transfer and the number of remaining transfers. The PDC has dedicated status registers which indicate if the transfer is enabled or disabled for each channel. The status for each channel is located in the peripheral status register. Transfers can be enabled and/or disabled by setting TXTEN/TXTDIS and RXTEN/RXTDIS in PDC Transfer Control Register. These control bits enable reading the pointer and counter registers safely without any risk of their changing between both reads.

The PDC sends status flags to the peripheral visible in its status-register (ENDRX, ENDTX, RXBUFF, and TXBUFE).

ENDRX flag is set when the PERIPH_RCR register reaches zero.

RXBUFF flag is set when both PERIPH_RCR and PERIPH_RNCR reach zero.

ENDTX flag is set when the PERIPH_TCR register reaches zero.

TXBUFE flag is set when both PERIPH_TCR and PERIPH_TNCR reach zero.

These status flags are described in the peripheral status register.

21.3.2 Memory Pointers

Each peripheral is connected to the PDC by a receiver data channel and a transmitter data channel. Each channel has an internal 32-bit memory pointer. Each memory pointer points to a location anywhere in the memory space (on-chip memory or external bus interface memory).

Depending on the type of transfer (byte, half-word or word), the memory pointer is incremented by 1, 2 or 4, respectively for peripheral transfers.

If a memory pointer is reprogrammed while the PDC is in operation, the transfer address is changed, and the PDC performs transfers using the new address.

21.3.3 Transfer Counters

There is one internal 16-bit transfer counter for each channel used to count the size of the block already transferred by its associated channel. These counters are decremented after each data transfer. When the counter reaches zero, the transfer is complete and the PDC stops transferring data.

If the Next Counter Register is equal to zero, the PDC disables the trigger while activating the related peripheral end flag.

If the counter is reprogrammed while the PDC is operating, the number of transfers is updated and the PDC counts transfers from the new value.

Programming the Next Counter/Pointer registers chains the buffers. The counters are decremented after each data transfer as stated above, but when the transfer counter reaches zero, the values of the Next Counter/Pointer are loaded into the Counter/Pointer registers in order to re-enable the triggers.

For each channel, two status bits indicate the end of the current buffer (ENDRX, ENTX) and the end of both current and next buffer (RXBUFF, TXBUFE). These bits are directly mapped to the peripheral status register and can trigger an interrupt request to the AIC.

The peripheral end flag is automatically cleared when one of the counter-registers (Counter or Next Counter Register) is written.

Note: When the Next Counter Register is loaded into the Counter Register, it is set to zero.

21.3.4 Data Transfers

The peripheral triggers PDC transfers using transmit (TXRDY) and receive (RXRDY) signals.

When the peripheral receives an external character, it sends a Receive Ready signal to the PDC which then requests access to the system bus. When access is granted, the PDC starts a read of the peripheral Receive Holding Register (RHR) and then triggers a write in the memory.

After each transfer, the relevant PDC memory pointer is incremented and the number of transfers left is decremented. When the memory block size is reached, a signal is sent to the peripheral and the transfer stops.

The same procedure is followed, in reverse, for transmit transfers.

21.3.5 Priority of PDC Transfer Requests

The Peripheral DMA Controller handles prioritized transfer requests from the channel.

If simultaneous requests of the same type (receiver or transmitter) occur on identical peripherals, the priority is determined by the numbering of the peripherals.

If transfer requests are not simultaneous, they are treated in the order they occurred. Requests from the receivers are handled first and then followed by transmitter requests.

21.4 Peripheral DMA Controller (PDC) User Interface

Table 21-1. Peripheral DMA Controller (PDC) Register Mapping

Offset	Register	Register Name	Read/Write	Reset
0x100	PDC Receive Pointer Register	PERIPH ⁽¹⁾ _RPR	Read/Write	0x0
0x104	PDC Receive Counter Register	PERIPH_RCR	Read/Write	0x0
0x108	PDC Transmit Pointer Register	PERIPH_TPR	Read/Write	0x0
0x10C	PDC Transmit Counter Register	PERIPH_TCR	Read/Write	0x0
0x110	PDC Receive Next Pointer Register	PERIPH_RNPR	Read/Write	0x0
0x114	PDC Receive Next Counter Register	PERIPH_RNCR	Read/Write	0x0
0x118	PDC Transmit Next Pointer Register	PERIPH_TNPR	Read/Write	0x0
0x11C	PDC Transmit Next Counter Register	PERIPH_TNCR	Read/Write	0x0
0x120	PDC Transfer Control Register	PERIPH_PTCR	Write-only	-
0x124	PDC Transfer Status Register	PERIPH_PTSR	Read-only	0x0

Note: 1. PERIPH: Ten registers are mapped in the peripheral memory space at the same offset. These can be defined by the user according to the function and the peripheral desired (DBGU, USART, SSC, SPI, MCI etc).

21.4.1 PDC Receive Pointer Register

Register Name: PERIPH_RPR

Access Type: Read/Write

31	30	29	28	27	26	25	24
RXPTR							
23	22	21	20	19	18	17	16
RXPTR							
15	14	13	12	11	10	9	8
RXPTR							
7	6	5	4	3	2	1	0
RXPTR							

- **RXPTR: Receive Pointer Address**

Address of the next receive transfer.

21.4.2 PDC Receive Counter Register

Register Name: PERIPH_RCR

Access Type: Read/Write

31	30	29	28	27	26	25	24
--							
23	22	21	20	19	18	17	16
--							
15	14	13	12	11	10	9	8
RXCTR							
7	6	5	4	3	2	1	0
RXCTR							

- **RXCTR: Receive Counter Value**

Number of receive transfers to be performed.

21.4.3 PDC Transmit Pointer Register

Register Name: PERIPH_TPR

Access Type: Read/Write

31	30	29	28	27	26	25	24
TXPTR							
23	22	21	20	19	18	17	16
TXPTR							
15	14	13	12	11	10	9	8
TXPTR							
7	6	5	4	3	2	1	0
TXPTR							

- **TXPTR: Transmit Pointer Address**

Address of the transmit buffer.

21.4.4 PDC Transmit Counter Register

Register Name: PERIPH_TCR

Access Type: Read/Write

31	30	29	28	27	26	25	24
--							
23	22	21	20	19	18	17	16
--							
15	14	13	12	11	10	9	8
TXCTR							
7	6	5	4	3	2	1	0
TXCTR							

- **TXCTR: Transmit Counter Value**

TXCTR is the size of the transmit transfer to be performed. At zero, the peripheral DMA transfer is stopped.

21.4.5 PDC Receive Next Pointer Register

Register Name: PERIPH_RNPR

Access Type: Read/Write

31	30	29	28	27	26	25	24
RXNPTR							
23	22	21	20	19	18	17	16
RXNPTR							
15	14	13	12	11	10	9	8
RXNPTR							
7	6	5	4	3	2	1	0
RXNPTR							

- **RXNPTR: Receive Next Pointer Address**

RXNPTR is the address of the next buffer to fill with received data when the current buffer is full.

21.4.6 PDC Receive Next Counter Register

Register Name: PERIPH_RNCR

Access Type: Read/Write

31	30	29	28	27	26	25	24
--							
23	22	21	20	19	18	17	16
--							
15	14	13	12	11	10	9	8
RXNCR							
7	6	5	4	3	2	1	0
RXNCR							

- **RXNCR: Receive Next Counter Value**

RXNCR is the size of the next buffer to receive.

21.4.7 PDC Transmit Next Pointer Register

Register Name: PERIPH_TNPR

Access Type: Read/Write

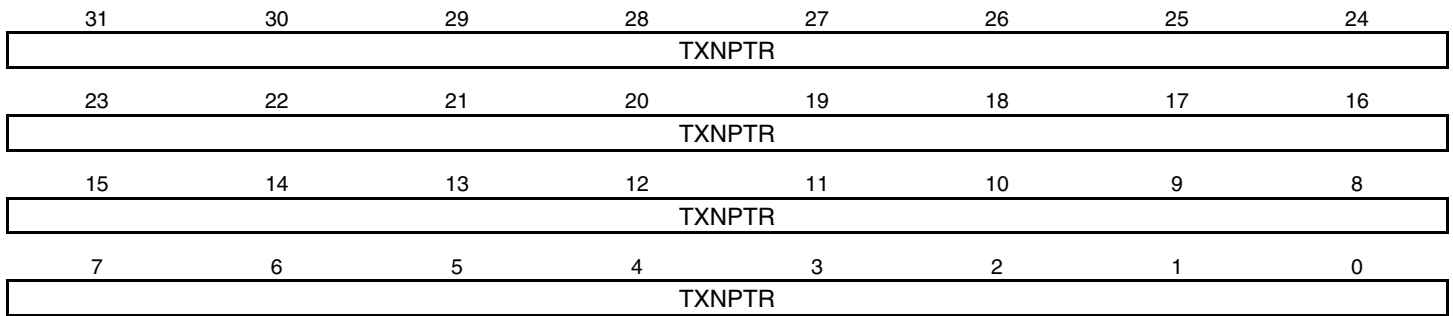

- **TXNPTR: Transmit Next Pointer Address**

TXNPTR is the address of the next buffer to transmit when the current buffer is empty.

21.4.8 PDC Transmit Next Counter Register

Register Name: PERIPH_TNCR

Access Type: Read/Write

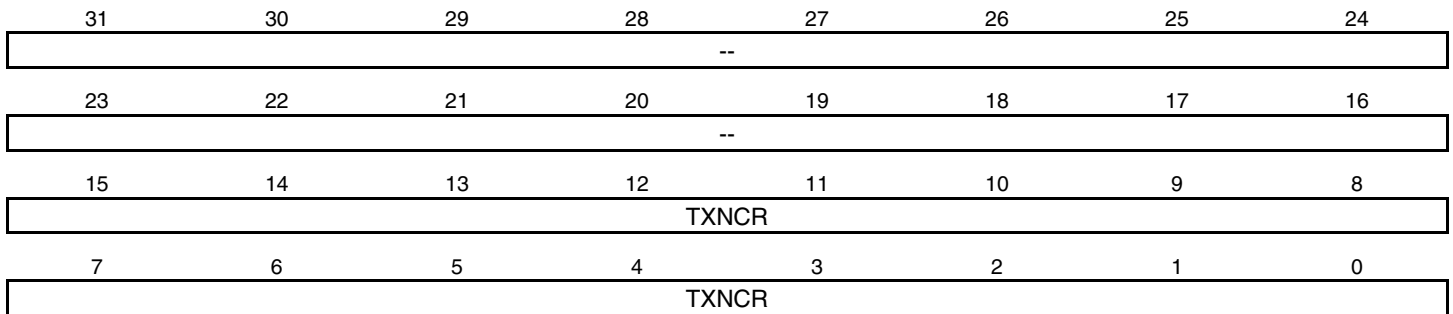

- **TXNCR: Transmit Next Counter Value**

TXNCR is the size of the next buffer to transmit.

21.4.9 PDC Transfer Control Register

Register Name: PERIPH_PTCR

Access Type: Write-only

31	30	29	28	27	26	25	24
–	–	–	–	–	–	–	–
23	22	21	20	19	18	17	16
–	–	–	–	–	–	–	–
15	14	13	12	11	10	9	8
–	–	–	–	–	–	TXTDIS	TXTEN
7	6	5	4	3	2	1	0
–	–	–	–	–	–	RXTDIS	RXTEN

- **RXTEN: Receiver Transfer Enable**

0 = No effect.

1 = Enables the receiver PDC transfer requests if RXTDIS is not set.

- **RXTDIS: Receiver Transfer Disable**

0 = No effect.

1 = Disables the receiver PDC transfer requests.

- **TXTEN: Transmitter Transfer Enable**

0 = No effect.

1 = Enables the transmitter PDC transfer requests.

- **TXTDIS: Transmitter Transfer Disable**

0 = No effect.

1 = Disables the transmitter PDC transfer requests

21.4.10 PDC Transfer Status Register

Register Name: PERIPH_PTSR

Access Type: Read-only

31	30	29	28	27	26	25	24
–	–	–	–	–	–	–	–
23	22	21	20	19	18	17	16
–	–	–	–	–	–	–	–
15	14	13	12	11	10	9	8
–	–	–	–	–	–	–	TXTEN
7	6	5	4	3	2	1	0
–	–	–	–	–	–	–	RXTEN

- **RXTEN: Receiver Transfer Enable**

0 = Receiver PDC transfer requests are disabled.

1 = Receiver PDC transfer requests are enabled.

- **TXTEN: Transmitter Transfer Enable**

0 = Transmitter PDC transfer requests are disabled.

1 = Transmitter PDC transfer requests are enabled.

22. Advanced Interrupt Controller (AIC)

22.1 Overview

The Advanced Interrupt Controller (AIC) is an 8-level priority, individually maskable, vectored interrupt controller, providing handling of up to thirty-two interrupt sources. It is designed to substantially reduce the software and real-time overhead in handling internal and external interrupts.

The AIC drives the nFIQ (fast interrupt request) and the nIRQ (standard interrupt request) inputs of an ARM processor. Inputs of the AIC are either internal peripheral interrupts or external interrupts coming from the product's pins.

The 8-level Priority Controller allows the user to define the priority for each interrupt source, thus permitting higher priority interrupts to be serviced even if a lower priority interrupt is being treated.

Internal interrupt sources can be programmed to be level sensitive or edge triggered. External interrupt sources can be programmed to be positive-edge or negative-edge triggered or high-level or low-level sensitive.

Important Features of the AIC are:

- Controls the Interrupt Lines (nIRQ and nFIQ) of an ARM Processor
- Thirty-two Individually Maskable and Vectored Interrupt Sources
 - Source 0 is Reserved for the Fast Interrupt Input (FIQ)
 - Source 1 is Reserved for System Peripherals (ST, RTC, PMC, DBGU...)
 - Source 2 to Source 31 Control up to Thirty Embedded Peripheral Interrupts or External Interrupts
 - Programmable Edge-triggered or Level-sensitive Internal Sources
 - Programmable Positive/Negative Edge-triggered or High/Low Level-sensitive External Sources
- 8-level Priority Controller
 - Drives the Normal Interrupt of the Processor
 - Handles Priority of the Interrupt Sources 1 to 31
 - Higher Priority Interrupts Can Be Served During Service of Lower Priority Interrupt
- Vectoring
 - Optimizes Interrupt Service Routine Branch and Execution
 - One 32-bit Vector Register per Interrupt Source
 - Interrupt Vector Register Reads the Corresponding Current Interrupt Vector
- Protect Mode
 - Easy Debugging by Preventing Automatic Operations when Protect Models Are Enabled
- General Interrupt Mask
 - Provides Processor Synchronization on Events Without Triggering an Interrupt

22.2 Block Diagram

Figure 22-1. Block Diagram

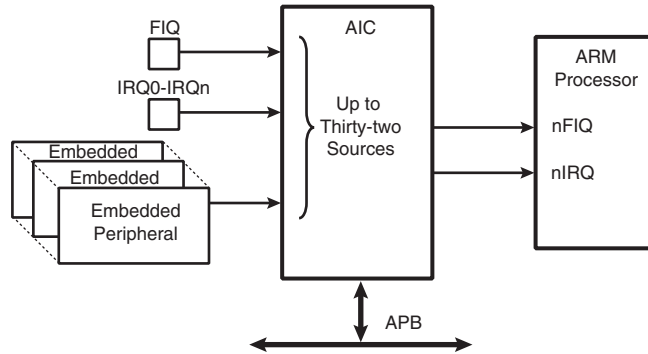

22.3 Application Block Diagram

Figure 22-2. Description of the Application Block

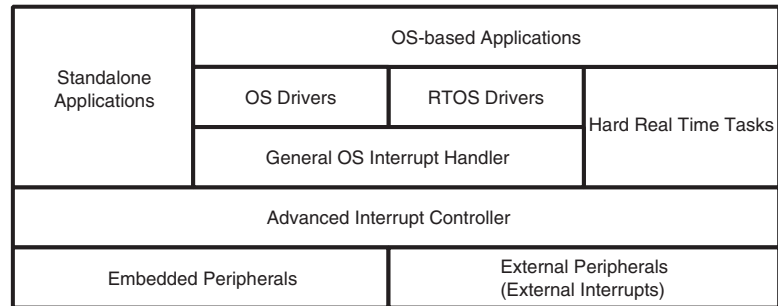

22.4 AIC Detailed Block Diagram

Figure 22-3. AIC Detailed Block Diagram

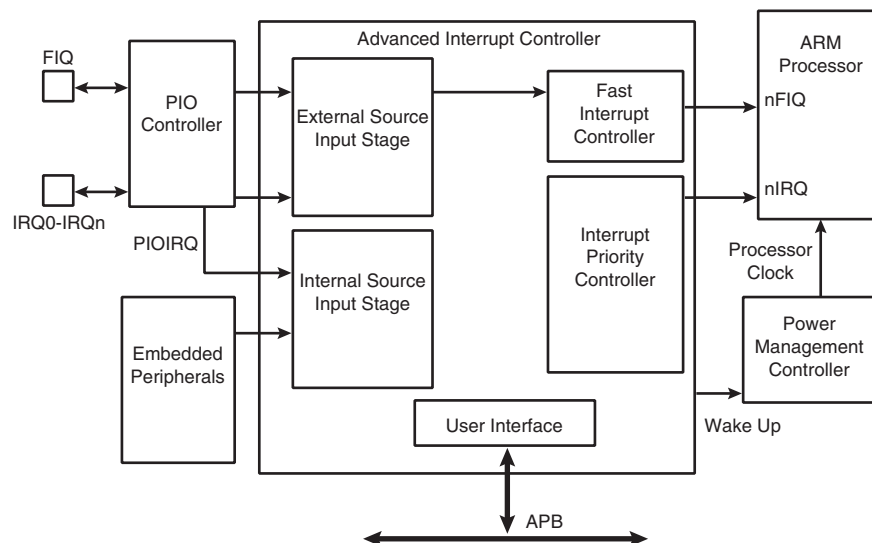

22.5 I/O Line Description

Table 22-1. I/O Line Description

Pin Name	Pin Description	Type
FIQ	Fast Interrupt	Input
IRQ0 - IRQn	Interrupt 0 - Interrupt n	Input

22.6 Product Dependencies

22.6.1 I/O Lines

The interrupt signals FIQ and IRQ0 to IRQn are normally multiplexed through the PIO controllers. Depending on the features of the PIO controller used in the product, the pins must be programmed in accordance with their assigned interrupt function. This is not applicable when the PIO controller used in the product is transparent on the input path.

22.6.2 Power Management

The Advanced Interrupt Controller is continuously clocked. The Power Management Controller has no effect on the Advanced Interrupt Controller behavior.

The assertion of the Advanced Interrupt Controller outputs, either nIRQ or nFIQ, wakes up the ARM processor while it is in Idle Mode. The General Interrupt Mask feature enables the AIC to wake up the processor without asserting the interrupt line of the processor, thus providing synchronization of the processor on an event.

22.6.3 Interrupt Sources

The Interrupt Source 0 is always located at FIQ. If the product does not feature an FIQ pin, the Interrupt Source 0 cannot be used.

The Interrupt Source 1 is always located at System Interrupt. This is the result of the OR-wiring of the system peripheral interrupt lines, such as the System Timer, the Real Time Clock, the Power Management Controller and the Memory Controller. When a system interrupt occurs, the service routine must first distinguish the cause of the interrupt. This is performed by reading successively the status registers of the above mentioned system peripherals.

The interrupt sources 2 to 31 can either be connected to the interrupt outputs of an embedded user peripheral or to external interrupt lines. The external interrupt lines can be connected directly, or through the PIO Controller.

The PIO Controllers are considered as user peripherals in the scope of interrupt handling. Accordingly, the PIO Controller interrupt lines are connected to the Interrupt Sources 2 to 31.

The peripheral identification defined at the product level corresponds to the interrupt source number (as well as the bit number controlling the clock of the peripheral). Consequently, to simplify the description of the functional operations and the user interface, the interrupt sources are named FIQ, SYS, and PID2 to PID31.

22.7 Functional Description

22.7.1 Interrupt Source Control

22.7.1.1 *Interrupt Source Mode*

The Advanced Interrupt Controller independently programs each interrupt source. The SRC_TYPE field of the corresponding AIC_SMR (Source Mode Register) selects the interrupt condition of each source.

The internal interrupt sources wired on the interrupt outputs of the embedded peripherals can be programmed either in level-sensitive mode or in edge-triggered mode. The active level of the internal interrupts is not important for the user.

The external interrupt sources can be programmed either in high level-sensitive or low level-sensitive modes, or in positive edge-triggered or negative edge-triggered modes.

22.7.1.2 *Interrupt Source Enabling*

Each interrupt source, including the FIQ in source 0, can be enabled or disabled by using the command registers; AIC_IECR (Interrupt Enable Command Register) and AIC_IDCR (Interrupt Disable Command Register). This set of registers conducts enabling or disabling in one instruction. The interrupt mask can be read in the AIC_IMR register. A disabled interrupt does not affect servicing of other interrupts.

22.7.1.3 *Interrupt Clearing and Setting*

All interrupt sources programmed to be edge-triggered (including the FIQ in source 0) can be individually set or cleared by writing respectively the AIC_ISCR and AIC_ICCR registers. Clearing or setting interrupt sources programmed in level-sensitive mode has no effect.

The clear operation is perfunctory, as the software must perform an action to reinitialize the “memorization” circuitry activated when the source is programmed in edge-triggered mode. However, the set operation is available for auto-test or software debug purposes. It can also be used to execute an AIC-implementation of a software interrupt.

The AIC features an automatic clear of the current interrupt when the AIC_IVR (Interrupt Vector Register) is read. Only the interrupt source being detected by the AIC as the current interrupt is affected by this operation. (See Section 22.7.3.1 “Priority Controller” on page 245.) The automatic clear reduces the operations required by the interrupt service routine entry code to reading the AIC_IVR.)

The automatic clear of the interrupt source 0 is performed when AIC_FVR is read.

22.7.1.4 *Interrupt Status*

For each interrupt, the AIC operation originates in AIC_IPR (Interrupt Pending Register) and its mask in AIC_IMR (Interrupt Mask Register). AIC_IPR enables the actual activity of the sources, whether masked or not.

The AIC_ISR register reads the number of the current interrupt (See Section 22.7.3.1 “Priority Controller” on page 245.) and the register AIC_CISR gives an image of the signals nIRQ and nFIQ driven on the processor.

Each status referred to above can be used to optimize the interrupt handling of the systems.

22.7.1.5 Internal Interrupt Source Input Stage

Figure 22-4. Internal Interrupt Source Input Stage

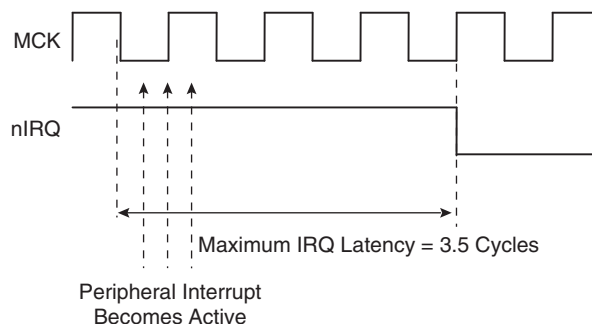

22.7.1.6 External Interrupt Source Input Stage

Figure 22-5. External Interrupt Source Input Stage

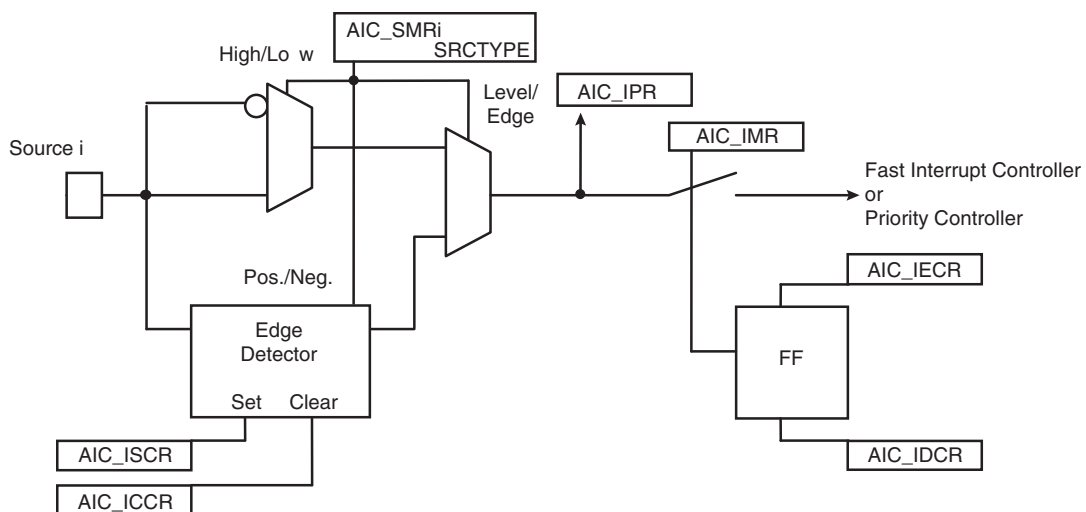

22.7.2 Interrupt Latencies

Global interrupt latencies depend on several parameters, including:

- The time the software masks the interrupts.
- Occurrence, either at the processor level or at the AIC level.
- The execution time of the instruction in progress when the interrupt occurs.
- The treatment of higher priority interrupts and the resynchronization of the hardware signals.

This section addresses only the hardware resynchronizations. It gives details of the latency times between the event on an external interrupt leading in a valid interrupt (edge or level) or the assertion of an internal interrupt source and the assertion of the nIRQ or nFIQ line on the processor. The resynchronization time depends on the programming of the interrupt source and on its type (internal or external). For the standard interrupt, resynchronization times are given assuming there is no higher priority in progress.

The PIO Controller multiplexing has no effect on the interrupt latencies of the external interrupt sources.

22.7.2.1 External Interrupt Edge Triggered Source

Figure 22-6. External Interrupt Edge Triggered Source

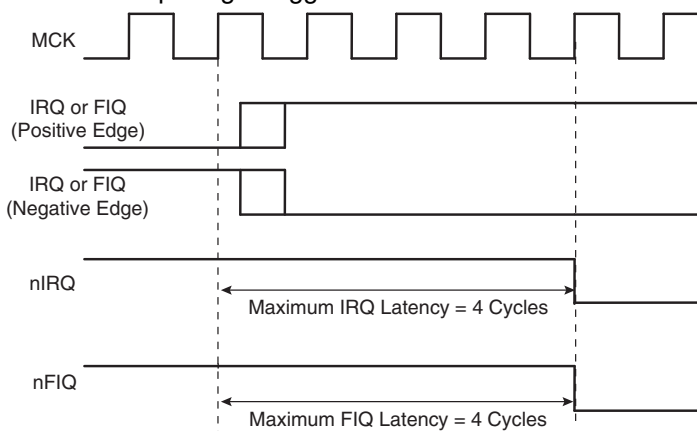

22.7.2.2 External Interrupt Level Sensitive Source

Figure 22-7. External Interrupt Level Sensitive Source

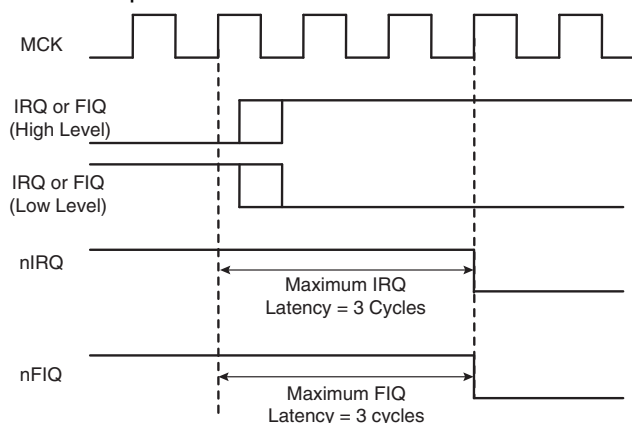

22.7.2.3 Internal Interrupt Edge Triggered Source

Figure 22-8. Internal Interrupt Edge Triggered Source

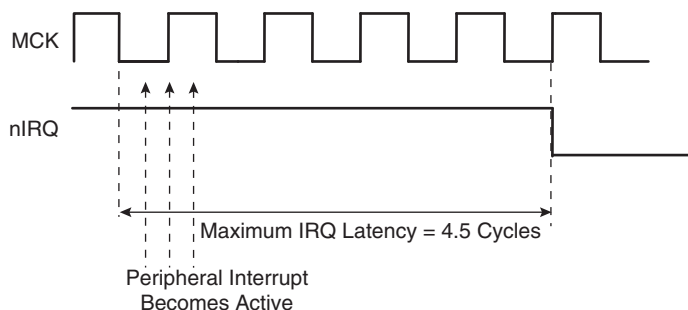

22.7.2.4 Internal Interrupt Level Sensitive Source

Figure 22-9. Internal Interrupt Level Sensitive Source

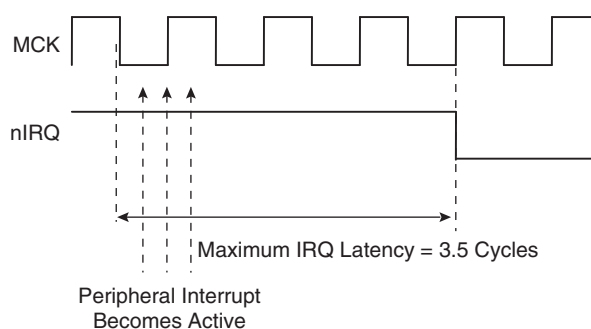

22.7.3 Normal Interrupt

22.7.3.1 Priority Controller

An 8-level priority controller drives the nIRQ line of the processor, depending on the interrupt conditions occurring on the interrupt sources 1 to 31.

Each interrupt source has a programmable priority level of 7 to 0, which is user-definable by writing the PRIOR field of the corresponding AIC_SMR (Source Mode Register). Level 7 is the highest priority and level 0 the lowest.

As soon as an interrupt condition occurs, as defined by the SRCTYPE field of the AIC_SVR (Source Vector Register), the nIRQ line is asserted. As a new interrupt condition might have happened on other interrupt sources since the nIRQ has been asserted, the priority controller determines the current interrupt at the time the AIC_IVR (Interrupt Vector Register) is read. **The read of AIC_IVR is the entry point of the interrupt handling** which allows the AIC to consider that the interrupt has been taken into account by the software.

The current priority level is defined as the priority level of the current interrupt.

If several interrupt sources of equal priority are pending and enabled when the AIC_IVR is read, the interrupt with the lowest interrupt source number is serviced first.

The nIRQ line can be asserted only if an interrupt condition occurs on an interrupt source with a higher priority. If an interrupt condition happens (or is pending) during the interrupt treatment in progress, it is delayed until the software indicates to the AIC the end of the current service by writing the AIC_EOICR (End of Interrupt Command Register). **The write of AIC_EOICR is the exit point of the interrupt handling.**

22.7.3.2 *Interrupt Nesting*

The priority controller utilizes interrupt nesting in order for the highest priority interrupt to be handled during the service of lower priority interrupts. This requires the interrupt service routines of the lower interrupts to re-enable the interrupt at the processor level.

When an interrupt of a higher priority happens during an already occurring interrupt service routine, the nIRQ line is re-asserted. If the interrupt is enabled at the core level, the current execution is interrupted and the new interrupt service routine should read the AIC_IVR. At this time, the current interrupt number and its priority level are pushed into an embedded hardware stack, so that they are saved and restored when the higher priority interrupt servicing is finished and the AIC_EOICR is written.

The AIC is equipped with an 8-level wide hardware stack in order to support up to eight interrupt nestings pursuant to having eight priority levels.

22.7.3.3 *Interrupt Vectoring*

The interrupt handler addresses corresponding to each interrupt source can be stored in the registers AIC_SVR1 to AIC_SVR31 (Source Vector Register 1 to 31). When the processor reads AIC_IVR (Interrupt Vector Register), the value written into AIC_SVR corresponding to the current interrupt is returned.

This feature offers a way to branch in one single instruction to the handler corresponding to the current interrupt, as AIC_IVR is mapped at the absolute address 0xFFFF F100 and thus accessible from the ARM interrupt vector at address 0x0000 0018 through the following instruction:

```
LDR PC, [PC, # -&F20]
```

When the processor executes this instruction, it loads the read value in AIC_IVR in its program counter, thus branching the execution on the correct interrupt handler.

This feature is often not used when the application is based on an operating system (either real time or not). Operating systems often have a single entry point for all the interrupts and the first task performed is to discern the source of the interrupt.

However, it is strongly recommended to port the operating system on AT91 products by supporting the interrupt vectoring. This can be performed by defining all the AIC_SVR of the interrupt source to be handled by the operating system at the address of its interrupt handler. When doing so, the interrupt vectoring permits a critical interrupt to transfer the execution on a specific very fast handler and not onto the operating system's general interrupt handler. This facilitates the support of hard real-time tasks (input/outputs of voice/audio buffers and software peripheral handling) to be handled efficiently and independently of the application running under an operating system.

22.7.3.4 *Interrupt Handlers*

This section gives an overview of the fast interrupt handling sequence when using the AIC. It is assumed that the programmer understands the architecture of the ARM processor, and especially the processor interrupt modes and the associated status bits.

It is assumed that:

1. The Advanced Interrupt Controller has been programmed, AIC_SVR registers are loaded with corresponding interrupt service routine addresses and interrupts are enabled.
2. The instruction at the ARM interrupt exception vector address is required to work with the vectoring

```
LDR PC, [PC, # -&F20]
```

When nIRQ is asserted, if the bit “I” of CPSR is 0, the sequence is as follows:

1. The CPSR is stored in SPSR_irq, the current value of the Program Counter is loaded in the Interrupt link register (R14_irq) and the Program Counter (R15) is loaded with 0x18. In the following cycle during fetch at address 0x1C, the ARM core adjusts R14_irq, decrementing it by four.
2. The ARM core enters Interrupt mode, if it has not already done so.
3. When the instruction loaded at address 0x18 is executed, the program counter is loaded with the value read in AIC_IVR. Reading the AIC_IVR has the following effects:
 - a. Sets the current interrupt to be the pending and enabled interrupt with the highest priority. The current level is the priority level of the current interrupt.
 - b. De-asserts the nIRQ line on the processor. Even if vectoring is not used, AIC_IVR must be read in order to de-assert nIRQ.
 - c. Automatically clears the interrupt, if it has been programmed to be edge-triggered.
 - d. Pushes the current level and the current interrupt number on to the stack.
 - e. Returns the value written in the AIC_SVR corresponding to the current interrupt.
4. The previous step has the effect of branching to the corresponding interrupt service routine. This should start by saving the link register (R14_irq) and SPSR_IRQ. The link register must be decremented by four when it is saved if it is to be restored directly into the program counter at the end of the interrupt. For example, the instruction `STB PC, LR, #4` may be used.
5. Further interrupts can then be unmasked by clearing the “I” bit in CPSR, allowing re-assertion of the nIRQ to be taken into account by the core. This can happen if an interrupt with a higher priority than the current interrupt occurs.
6. The interrupt handler can then proceed as required, saving the registers that will be used and restoring them at the end. During this phase, an interrupt of higher priority than the current level will restart the sequence from step 1.

Note: If the interrupt is programmed to be level sensitive, the source of the interrupt must be cleared during this phase.

7. The “I” bit in CPSR must be set in order to mask interrupts before exiting to ensure that the interrupt is completed in an orderly manner.
8. The End of Interrupt Command Register (AIC_EOICR) must be written in order to indicate to the AIC that the current interrupt is finished. This causes the current level to be popped from the stack, restoring the previous current level if one exists on the stack. If another interrupt is pending, with lower or equal priority than the old current level but with higher priority than the new current level, the nIRQ line is re-asserted, but the interrupt sequence does not immediately start because the “I” bit is set in the core. SPSR_irq is restored. Finally, the saved value of the link register is restored directly into the PC. This has effect of returning from the interrupt to whatever was being executed before, and of loading the CPSR with the stored SPSR, masking or unmasking the interrupts depending on the state saved in SPSR_irq.

Note: The “I” bit in SPSR is significant. If it is set, it indicates that the ARM core was on the verge of masking an interrupt when the mask instruction was interrupted. Hence, when SPSR is restored, the mask instruction is completed (interrupt is masked).

22.7.4 Fast Interrupt

22.7.4.1 Fast Interrupt Source

The interrupt source 0 is the only source which can raise a fast interrupt request to the processor. The interrupt source 0 is generally connected to an FIQ pin of the product, either directly or through a PIO Controller.

22.7.4.2 Fast Interrupt Control

The fast interrupt logic of the AIC has no priority controller. The mode of interrupt source 0 is programmed with the AIC_SMR0 and the field PRIOR of this register is not used even if it reads what has been written. The field SRCTYPE of AIC_SMR0 enables programming the fast interrupt source to be positive-edge triggered or negative-edge triggered or high-level sensitive or low-level sensitive

Writing 0x1 in the AIC_IECR (Interrupt Enable Command Register) and AIC_IDCR (Interrupt Disable Command Register) respectively enables and disables the fast interrupt. The bit 0 of AIC_IMR (Interrupt Mask Register) indicates whether the fast interrupt is enabled or disabled.

22.7.4.3 Fast Interrupt Vectoring

The fast interrupt handler address can be stored in AIC_SVR0 (Source Vector Register 0). The value written into this register is returned when the processor reads AIC_FVR (Fast Vector Register). This offers a way to branch in one single instruction to the interrupt handler, as AIC_FVR is mapped at the absolute address 0xFFFF F104 and thus accessible from the ARM fast interrupt vector at address 0x0000 001C through the following instruction:

```
LDR PC, [PC, # -&F20]
```

When the processor executes this instruction it loads the value read in AIC_FVR in its program counter, thus branching the execution on the fast interrupt handler. It also automatically performs the clear of the fast interrupt source if it is programmed in edge-triggered mode.

22.7.4.4 Fast Interrupt Handlers

This section gives an overview of the fast interrupt handling sequence when using the AIC. It is assumed that the programmer understands the architecture of the ARM processor, and especially the processor interrupt modes and associated status bits.

Assuming that:

1. The Advanced Interrupt Controller has been programmed, AIC_SVR0 is loaded with the fast interrupt service routine address, and the interrupt source 0 is enabled.
2. The Instruction at address 0x1C (FIQ exception vector address) is required to vector the fast interrupt:

```
LDR PC, [PC, # -&F20]
```

3. The user does not need nested fast interrupts.

When nFIQ is asserted if the bit “F” of CPSR is 0, the sequence is:

1. The CPSR is stored in SPSR_fiq, the current value of the program counter is loaded in the FIQ link register (R14_FIQ) and the program counter (R15) is loaded with 0x1C. In

the following cycle, during fetch at address 0x20, the ARM core adjusts R14_fiq, decrementing it by four.

2. The ARM core enters FIQ mode.
3. When the instruction loaded at address 0x1C is executed, the program counter is loaded with the value read in AIC_FVR. Reading the AIC_FVR has effect of automatically clearing the fast interrupt, if it has been programmed to be edge triggered. In this case only, it de-asserts the nFIQ line on the processor.
4. The previous step enables branching to the corresponding interrupt service routine. It is not necessary to save the link register R14_fiq and SPSR_fiq if nested fast interrupts are not needed.
5. The Interrupt Handler can then proceed as required. It is not necessary to save registers R8 to R13 because FIQ mode has its own dedicated registers and the user R8 to R13 are banked. The other registers, R0 to R7, must be saved before being used, and restored at the end (before the next step). Note that if the fast interrupt is programmed to be level sensitive, the source of the interrupt must be cleared during this phase in order to de-assert the interrupt source 0.
6. Finally, the Link Register R14_fiq is restored into the PC after decrementing it by four (with instruction `SUB PC, LR, #4` for example). This has the effect of returning from the interrupt to whatever was being executed before, loading the CPSR with the SPSR and masking or unmasking the fast interrupt depending on the state saved in the SPSR.

Note: The “F” bit in SPSR is significant. If it is set, it indicates that the ARM core was just about to mask FIQ interrupts when the mask instruction was interrupted. Hence when the SPSR is restored, the interrupted instruction is completed (FIQ is masked).

Another way to handle the fast interrupt is to map the interrupt service routine at the address of the ARM vector 0x1C. This method does not use the vectoring, so that reading AIC_FVR must be performed at the very beginning of the handler operation. However, this method saves the execution of a branch instruction.

22.7.5 Protect Mode

The Protect Mode permits reading the Interrupt Vector Register without performing the associated automatic operations. This is necessary when working with a debug system. When a debugger, working either with a Debug Monitor or the ARM processor's ICE, stops the applications and updates the opened windows, it might read the AIC User Interface and thus the IVR. This has undesirable consequences:

- If an enabled interrupt with a higher priority than the current one is pending, it is stacked.
- If there is no enabled pending interrupt, the spurious vector is returned.

In either case, an End of Interrupt command is necessary to acknowledge and to restore the context of the AIC. This operation is generally not performed by the debug system as the debug system would become strongly intrusive and cause the application to enter an undesired state.

This is avoided by using the Protect Mode. Writing DBGM in AIC_DCR (Debug Control Register) at 0x1 enables the Protect Mode.

When the Protect Mode is enabled, the AIC performs interrupt stacking only when a write access is performed on the AIC_IVR. Therefore, the Interrupt Service Routines must write (arbitrary data) to the AIC_IVR just after reading it. The new context of the AIC, including the value of the Interrupt Status Register (AIC_ISR), is updated with the current interrupt only when AIC_IVR is written.

An AIC_IVR read on its own (e.g., by a debugger), modifies neither the AIC context nor the AIC_ISR. Extra AIC_IVR reads perform the same operations. However, it is recommended to not stop the processor between the read and the write of AIC_IVR of the interrupt service routine to make sure the debugger does not modify the AIC context.

To summarize, in normal operating mode, the read of AIC_IVR performs the following operations within the AIC:

1. Calculates active interrupt (higher than current or spurious).
2. Determines and returns the vector of the active interrupt.
3. Memorizes the interrupt.
4. Pushes the current priority level onto the internal stack.
5. Acknowledges the interrupt.

However, while the Protect Mode is activated, only operations 1 to 3 are performed when AIC_IVR is read. Operations 4 and 5 are only performed by the AIC when AIC_IVR is written.

Software that has been written and debugged using the Protect Mode runs correctly in Normal Mode without modification. However, in Normal Mode the AIC_IVR write has no effect and can be removed to optimize the code.

22.7.6 Spurious Interrupt

The Advanced Interrupt Controller features protection against spurious interrupts. A spurious interrupt is defined as being the assertion of an interrupt source long enough for the AIC to assert the nIRQ, but no longer present when AIC_IVR is read. This is most prone to occur when:

- An external interrupt source is programmed in level-sensitive mode and an active level occurs for only a short time.
- An internal interrupt source is programmed in level sensitive and the output signal of the corresponding embedded peripheral is activated for a short time. (As in the case for the Watchdog.)
- An interrupt occurs just a few cycles before the software begins to mask it, thus resulting in a pulse on the interrupt source.

The AIC detects a spurious interrupt at the time the AIC_IVR is read while no enabled interrupt source is pending. When this happens, the AIC returns the value stored by the programmer in AIC_SPU (Spurious Vector Register). The programmer must store the address of a spurious interrupt handler in AIC_SPU as part of the application, to enable an as fast as possible return to the normal execution flow. This handler writes in AIC_EOICR and performs a return from interrupt.

22.7.7 General Interrupt Mask

The AIC features a General Interrupt Mask bit to prevent interrupts from reaching the processor. Both the nIRQ and the nFIQ lines are driven to their inactive state if the bit GMSK in AIC_DCR (Debug Control Register) is set. However, this mask does not prevent waking up the processor if it has entered Idle Mode. This function facilitates synchronizing the processor on a next event and, as soon as the event occurs, performs subsequent operations without having to handle an interrupt. It is strongly recommended to use this mask with caution.

22.8 Advanced Interrupt Controller (AIC) User Interface

22.8.1 Base Address

The AIC is mapped at the address **0xFFFF F000**. It has a total 4-Kbyte addressing space. This permits the vectoring feature, as the PC-relative load/store instructions of the ARM processor supports only an ± 4 -Kbyte offset.

Table 22-2. Register Mapping

Offset	Register	Name	Access	Reset Value
0000	Source Mode Register 0	AIC_SMR0	Read/Write	0x0
0x04	Source Mode Register 1	AIC_SMR1	Read/Write	0x0
–	–	–	–	–
0x7C	Source Mode Register 31	AIC_SMR31	Read/Write	0x0
0x80	Source Vector Register 0	AIC_SVR0	Read/Write	0x0
0x84	Source Vector Register 1	AIC_SVR1	Read/Write	0x0
–	–	–	–	–
0xFC	Source Vector Register 31	AIC_SVR31	Read/Write	0x0
0x100	Interrupt Vector Register	AIC_IVR	Read-only	0x0
0x104	Fast Interrupt Vector Register	AIC_FVR	Read-only	0x0
0x108	Interrupt Status Register	AIC_ISR	Read-only	0x0
0x10C	Interrupt Pending Register	AIC_IPR	Read-only	0x0 ⁽¹⁾
0x110	Interrupt Mask Register	AIC_IMR	Read-only	0x0
0x114	Core Interrupt Status Register	AIC_CISR	Read-only	0x0
0x118	Reserved	–	–	–
0x11C	Reserved	–	–	–
0x120	Interrupt Enable Command Register	AIC_IECR	Write-only	–
0x124	Interrupt Disable Command Register	AIC_IDCR	Write-only	–
0x128	Interrupt Clear Command Register	AIC_ICCR	Write-only	–
0x12C	Interrupt Set Command Register	AIC_ISCR	Write-only	–
0x130	End of Interrupt Command Register	AIC_EOICR	Write-only	–
0x134	Spurious Interrupt Vector Register	AIC_SPU	Read/Write	0x0
0x138	Debug Control Register	AIC_DCR	Read/Write	0x0
0x13C	Reserved	–	–	–

Note: 1. The reset value of the Interrupt Pending Register depends on the level of the external interrupt source. All other sources are cleared at reset, thus not pending.

22.8.2 AIC Source Mode Register

Register Name: AIC_SMR0..AIC_SMR31

Access Type: Read/Write

Reset Value: 0x0

31	30	29	28	27	26	25	24	
–	–	–	–	–	–	–	–	
23	22	21	20	19	18	17	16	
–	–	–	–	–	–	–	–	
15	14	13	12	11	10	9	8	
–	–	–	–	–	–	–	–	
7	6	5	4	3	2	1	0	
–	SRCTYPE		–	–	PRIOR			–

- **PRIOR: Priority Level**

Programs the priority level for all sources except FIQ source (source 0).

The priority level can be between 0 (lowest) and 7 (highest).

The priority level is not used for the FIQ in the related SMR register AIC_SMRx.

- **SRCTYPE: Interrupt Source Type**

The active level or edge is not programmable for the internal interrupt sources.

SRCTYPE		Internal Interrupt Sources	External Interrupt Sources
0	0	High-level Sensitive	Low-level Sensitive
0	1	Positive-edge Triggered	Negative-edge Triggered
1	0	High-level Sensitive	High-level Sensitive
1	1	Positive-edge Triggered	Positive-edge Triggered

22.8.3 AIC Source Vector Register

Register Name: AIC_SVR0..AIC_SVR31

Access Type: Read/Write

Reset Value: 0x0

31	30	29	28	27	26	25	24
VECTOR							
23	22	21	20	19	18	17	16
VECTOR							
15	14	13	12	11	10	9	8
VECTOR							
7	6	5	4	3	2	1	0
VECTOR							

- **VECTOR: Source Vector**

The user may store in these registers the addresses of the corresponding handler for each interrupt source.

22.8.4 AIC Interrupt Vector Register

Register Name: AIC_IVR

Access Type: Read-only

Reset Value: 0

31	30	29	28	27	26	25	24
IRQV							
23	22	21	20	19	18	17	16
IRQV							
15	14	13	12	11	10	9	8
IRQV							
7	6	5	4	3	2	1	0
IRQV							

- **IRQV: Interrupt Vector Register**

The Interrupt Vector Register contains the vector programmed by the user in the Source Vector Register corresponding to the current interrupt.

The Source Vector Register is indexed using the current interrupt number when the Interrupt Vector Register is read.

When there is no current interrupt, the Interrupt Vector Register reads the value stored in AIC_SPU.

22.8.5 AIC FIQ Vector Register

Register Name: AIC_FVR

Access Type: Read-only

Reset Value: 0

31	30	29	28	27	26	25	24
FIQV							
23	22	21	20	19	18	17	16
FIQV							
15	14	13	12	11	10	9	8
FIQV							
7	6	5	4	3	2	1	0
FIQV							

- **FIQV: FIQ Vector Register**

The FIQ Vector Register contains the vector programmed by the user in the Source Vector Register 0. When there is no fast interrupt, the Fast Interrupt Vector Register reads the value stored in AIC_SPU.

22.8.6 AIC Interrupt Status Register

Register Name: AIC_ISR

Access Type: Read-only

Reset Value: 0

31	30	29	28	27	26	25	24		
-	-	-	-	-	-	-	-		
23	22	21	20	19	18	17	16		
-	-	-	-	-	-	-	-		
15	14	13	12	11	10	9	8		
-	-	-	-	-	-	-	-		
7	6	5	4	3	2	1	0		
-	-	-	IRQID					-	-

- **IRQID: Current Interrupt Identifier**

The Interrupt Status Register returns the current interrupt source number.

22.8.7 AIC Interrupt Pending Register

Register Name: AIC_IPR

Access Type: Read-only

Reset Value: 0

31	30	29	28	27	26	25	24
PID31	PID30	PID29	PID28	PID27	PID26	PID25	PID24
23	22	21	20	19	18	17	16
PID23	PID22	PID21	PID20	PID19	PID18	PID17	PID16
15	14	13	12	11	10	9	8
PID15	PID14	PID13	PID12	PID11	PID10	PID9	PID8
7	6	5	4	3	2	1	0
PID7	PID6	PID5	PID4	PID3	PID2	SYS	FIQ

- **FIQ, SYS, PID2-PID31: Interrupt Pending**

0 = Corresponding interrupt is no pending.

1 = Corresponding interrupt is pending.

22.8.8 AIC Interrupt Mask Register

Register Name: AIC_IMR

Access Type: Read-only

Reset Value: 0

31	30	29	28	27	26	25	24
PID31	PID30	PID29	PID28	PID27	PID26	PID25	PID24
23	22	21	20	19	18	17	16
PID23	PID22	PID21	PID20	PID19	PID18	PID17	PID16
15	14	13	12	11	10	9	8
PID15	PID14	PID13	PID12	PID11	PID10	PID9	PID8
7	6	5	4	3	2	1	0
PID7	PID6	PID5	PID4	PID3	PID2	SYS	FIQ

- **FIQ, SYS, PID2-PID31: Interrupt Mask**

0 = Corresponding interrupt is disabled.

1 = Corresponding interrupt is enabled.

22.8.9 AIC Core Interrupt Status Register

Register Name: AIC_CISR

Access Type: Read-only

Reset Value: 0

31	30	29	28	27	26	25	24
–	–	–	–	–	–	–	–
23	22	21	20	19	18	17	16
–	–	–	–	–	–	–	–
15	14	13	12	11	10	9	8
–	–	–	–	–	–	–	–
7	6	5	4	3	2	1	0
–	–	–	–	–	–	NIRQ	NFIQ

• **NFIQ: NFIQ Status**

0 = nFIQ line is deactivated.

1 = nFIQ line is active.

• **NIRQ: NIRQ Status**

0 = nIRQ line is deactivated.

1 = nIRQ line is active.

22.8.10 AIC Interrupt Enable Command Register

Register Name: AIC_IECR

Access Type: Write-only

31	30	29	28	27	26	25	24
PID31	PID30	PID29	PID28	PID27	PID26	PID25	PID24
23	22	21	20	19	18	17	16
PID23	PID22	PID21	PID20	PID19	PID18	PID17	PID16
15	14	13	12	11	10	9	8
PID15	PID14	PID13	PID12	PID11	PID10	PID9	PID8
7	6	5	4	3	2	1	0
PID7	PID6	PID5	PID4	PID3	PID2	SYS	FIQ

• **FIQ, SYS, PID2-PID3: Interrupt Enable**

0 = No effect.

1 = Enables corresponding interrupt.

22.8.11 AIC Interrupt Disable Command Register

Register Name: AIC_IDCR

Access Type: Write-only

31	30	29	28	27	26	25	24
PID31	PID30	PID29	PID28	PID27	PID26	PID25	PID24
23	22	21	20	19	18	17	16
PID23	PID22	PID21	PID20	PID19	PID18	PID17	PID16
15	14	13	12	11	10	9	8
PID15	PID14	PID13	PID12	PID11	PID10	PID9	PID8
7	6	5	4	3	2	1	0
PID7	PID6	PID5	PID4	PID3	PID2	SYS	FIQ

- FIQ, SYS, PID2-PID31: Interrupt Disable**

0 = No effect.

1 = Disables corresponding interrupt.

22.8.12 AIC Interrupt Clear Command Register

Register Name: AIC_ICCR

Access Type: Write-only

31	30	29	28	27	26	25	24
PID31	PID30	PID29	PID28	PID27	PID26	PID25	PID24
23	22	21	20	19	18	17	16
PID23	PID22	PID21	PID20	PID19	PID18	PID17	PID16
15	14	13	12	11	10	9	8
PID15	PID14	PID13	PID12	PID11	PID10	PID9	PID8
7	6	5	4	3	2	1	0
PID7	PID6	PID5	PID4	PID3	PID2	SYS	FIQ

- FIQ, SYS, PID2-PID31: Interrupt Clear**

0 = No effect.

1 = Clears corresponding interrupt.

22.8.13 AIC Interrupt Set Command Register

Register Name: AIC_ISCR

Access Type: Write-only

31	30	29	28	27	26	25	24
PID31	PID30	PID29	PID28	PID27	PID26	PID25	PID24
23	22	21	20	19	18	17	16
PID23	PID22	PID21	PID20	PID19	PID18	PID17	PID16
15	14	13	12	11	10	9	8
PID15	PID14	PID13	PID12	PID11	PID10	PID9	PID8
7	6	5	4	3	2	1	0
PID7	PID6	PID5	PID4	PID3	PID2	SYS	FIQ

• **FIQ, SYS, PID2-PID31: Interrupt Set**

0 = No effect.

1 = Sets corresponding interrupt.

22.8.14 AIC End of Interrupt Command Register

Register Name: AIC_EOICR

Access Type: Write-only

31	30	29	28	27	26	25	24
-	-	-	-	-	-	-	-
23	22	21	20	19	18	17	16
-	-	-	-	-	-	-	-
15	14	13	12	11	10	9	8
-	-	-	-	-	-	-	-
7	6	5	4	3	2	1	0
-	-	-	-	-	-	-	-

The End of Interrupt Command Register is used by the interrupt routine to indicate that the interrupt treatment is complete. Any value can be written because it is only necessary to make a write to this register location to signal the end of interrupt treatment.

22.8.15 AIC Spurious Interrupt Vector Register

Register Name: AIC_SPU

Access Type: Read/Write

Reset Value: 0

31	30	29	28	27	26	25	24
SIQV							
23	22	21	20	19	18	17	16
SIQV							
15	14	13	12	11	10	9	8
SIQV							
7	6	5	4	3	2	1	0
SIQV							

• **SIQV: Spurious Interrupt Vector Register**

The user may store the address of a spurious interrupt handler in this register. The written value is returned in AIC_IVR in case of a spurious interrupt and in AIC_FVR in case of a spurious fast interrupt.

22.8.16 AIC Debug Control Register

Register Name: AIC_DEBUG

Access Type: Read/Write

Reset Value: 0

31	30	29	28	27	26	25	24
–	–	–	–	–	–	–	–
23	22	21	20	19	18	17	16
–	–	–	–	–	–	–	–
15	14	13	12	11	10	9	8
–	–	–	–	–	–	–	–
7	6	5	4	3	2	1	0
–	–	–	–	–	–	GMSK	PROT

- **PROT: Protection Mode**

0 = The Protection Mode is disabled.

1 = The Protection Mode is enabled.

- **GMSK: General Mask**

0 = The nIRQ and nFIQ lines are normally controlled by the AIC.

1 = The nIRQ and nFIQ lines are tied to their inactive state.

23. Power Management Controller (PMC)

23.1 Overview

The Power Management Controller (PMC) generates all the clocks of a system thanks to the integration of two oscillators and two PLLs.

The PMC provides clocks to the embedded processor and enables the idle mode by stopping the processor clock until the next interrupt.

The PMC independently provides and controls up to thirty peripheral clocks and four programmable clocks that can be used as outputs on pins to feed external devices. The integration of the PLLs supplies the USB devices and host ports with a 48 MHz clock, as required by the bus speed, and the rest of the system with a clock at another frequency. Thus, the fully-featured Power Management Controller optimizes power consumption of the whole system and supports the Normal, Idle, Slow Clock and Standby operating modes.

The main features of the PMC are:

- Optimize the Power Consumption of the Whole System
- Embeds and Controls:
 - One Main Oscillator and One Slow Clock Oscillator (32.768 kHz)
 - Two Phase Locked Loops (PLLs) and Dividers
 - Clock Prescalers
- Provides:
 - the Processor Clock PCK
 - the Master Clock MCK
 - the USB Clocks, UHPCK and UDPCK, Respectively for the USB Host Port and the USB Device Port
 - Programmable Automatic PLL Switch-off in USB Device Suspend Conditions
 - up to Thirty Peripheral Clocks
 - up to Four Programmable Clock Outputs
- Four Operating Modes:
 - Normal Mode, Idle Mode, Slow Clock Mode, Standby Mode

23.2 Product Dependencies

23.2.1 I/O Lines

The Power Management Controller is capable of handling up to four Programmable Clocks, PCK0 to PCK3.

A Programmable Clock is generally multiplexed on a PIO Controller. The user must first program the PIO controllers to assign the pins of the Programmable Clock to its peripheral function.

23.2.2 Interrupt

The Power Management Controller has an interrupt line connected to the Advanced Interrupt Controller (AIC). Handling the PMC interrupt requires programming the AIC before configuring the PMC.

23.2.3 Oscillator and PLL Characteristics

The electrical characteristics of the embedded oscillators and PLLs are product-dependent, even if the way to control them is similar.

All of the parameters for both oscillators and the PLLs are given in the DC Characteristics section of the product datasheet. These figures are used not only for the hardware design, as they affect the external components to be connected to the pins, but also the software configuration, as they determine the waiting time for the startup and lock times to be programmed.

23.2.4 Peripheral Clocks

The Power Management Controller provides and controls up to thirty peripheral clocks. The bit number permitting the control of a peripheral clock is the Peripheral ID of the embedded peripheral.

When the Peripheral ID does not correspond to a peripheral, either because this is an external interrupt or because there are less than thirty peripherals, the control bits of the Peripheral ID are not implemented in the PMC and programming them has no effect on the behavior of the PMC.

23.2.5 USB Clocks

The Power Management Controller provides and controls two USB Clocks, the UHPCK for the USB Host Port, and the UDPCK for the USB Device.

If the product does not embed either the USB Host Port or the USB Device Port, the associated control bits and registers are not implemented in the PMC and programming them has no effect on the behavior of the PMC.

23.3 Block Diagram

Figure 23-1. Power Management Controller Block Diagram

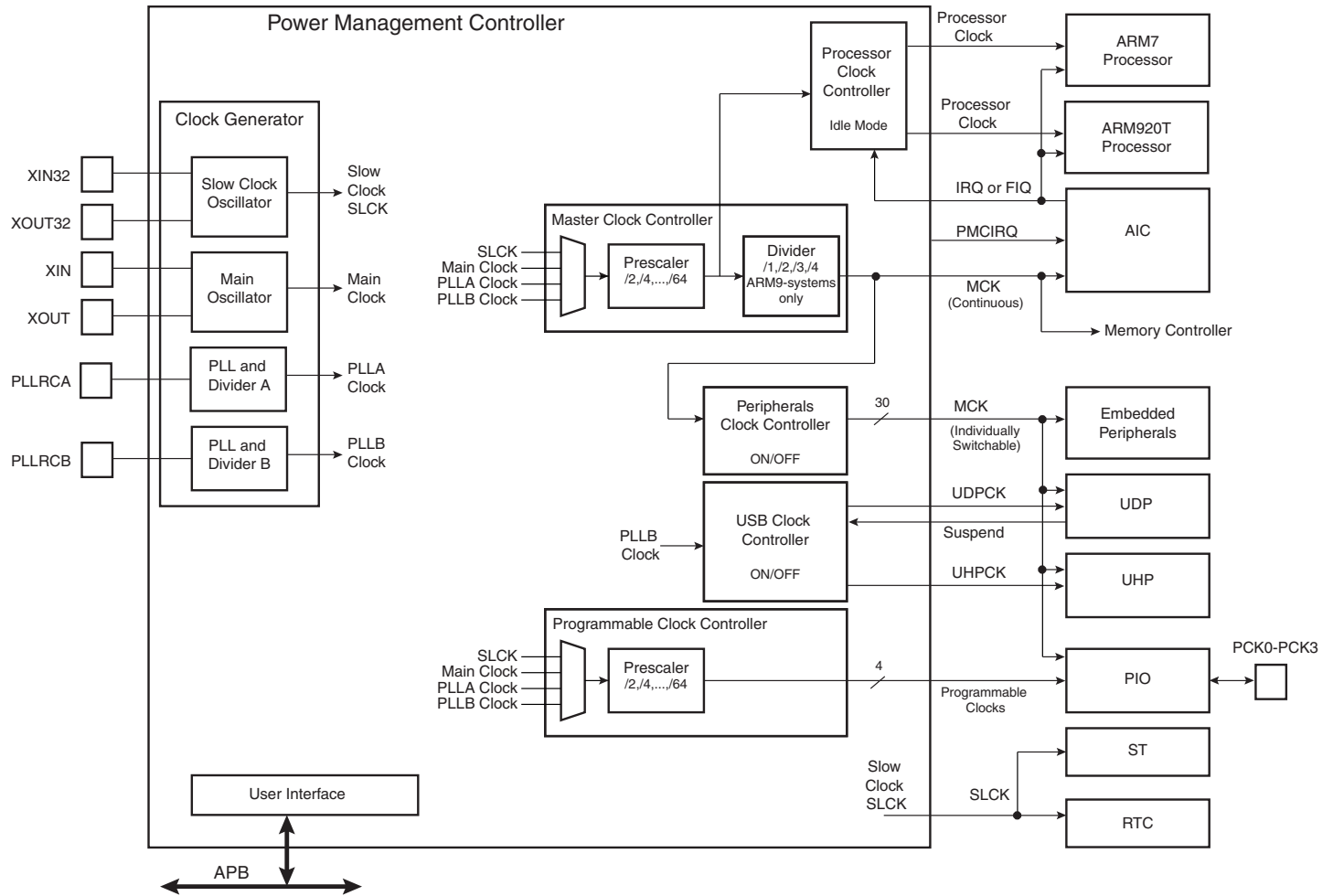

23.4 Functional Description

23.4.1 Operating Modes Definition

The following operating modes are supported by the PMC and offer different power consumption levels and event response latency times:

- Normal Mode: The ARM processor clock is enabled and peripheral clocks are enabled depending on application requirements.
- Idle Mode: The ARM processor clock is disabled and waiting for the next interrupt (or a main reset). The peripheral clocks are enabled depending on application requirements. PDC transfers are still possible.
- Slow Clock Mode: Slow clock mode is similar to normal mode, but the main oscillator and the PLL are switched off to save power and the processor and the peripherals run in Slow Clock mode. Note that slow clock mode is the mode selected after the reset.
- Standby Mode: Standby mode is a combination of Slow Clock mode and Idle Mode. It enables the processor to respond quickly to a wake-up event by keeping power consumption very low.

23.4.2 Clock Definitions

The Power Management Controller provides the following clocks:

- Slow Clock (SLCK), typically at 32.768 kHz, is the only permanent clock within the system.
- Master Clock (MCK), programmable from a few hundred Hz to the maximum operating frequency of the device. It is available to the modules running permanently, such as the AIC and the Memory Controller.
- Processor Clock (PCK), typically the Master Clock for ARM7-based systems and a faster clock on ARM9-based systems, switched off when entering idle mode.
- Peripheral Clocks, typically MCK, provided to the embedded peripherals (USART, SSC, SPI, TWI, TC, MCI, etc.) and independently controllable. In order to reduce the number of clock names in a product, the Peripheral Clocks are named MCK in the product datasheet.
- UDP Clock (UDPCK), typically at 48 MHz, required by the USB Device Port operations.
- UHP Clock (UHPCK), typically at 48 MHz, required by the USB Host Port operations.
- Programmable Clock Outputs (PCK0 to PCK3) can be selected from the clocks provided by the clock generator and driven on the PCK0 to PCK3 pins.

23.4.3 Clock Generator

The Clock Generator embeds:

- the Slow Clock Oscillator
- the Main Oscillator
- two PLL and divider blocks, A and B

The Clock Generator may optionally integrate a divider by 2. The ARM7-based systems generally embed PLLs able to output between 20 MHz and 100 MHz and do not embed the divider by 2. The ARM9-based systems generally embed PLLs able to output between 80 MHz and 180 MHz. As the 48 MHz required by the USB cannot be reached by such a PLL, the optional divider by 2 is implemented.

The block diagram of the Clock Generator is shown in [Figure 23-2](#).

Figure 23-2. Clock Generator Block Diagram

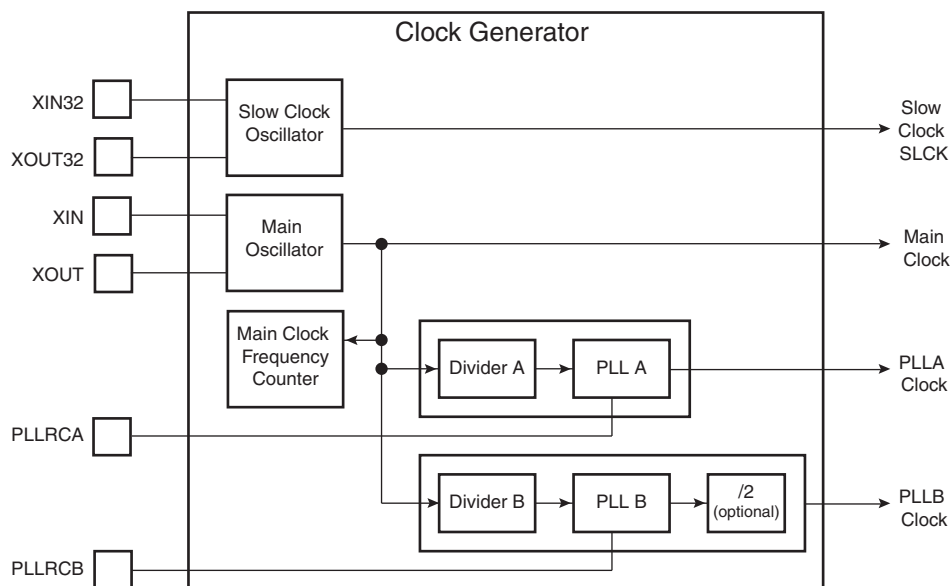

23.4.4 Slow Clock Oscillator

23.4.4.1 Slow Clock Oscillator Connection

The Clock Generator integrates a low-power 32.768 kHz oscillator. The XIN32 and XOUT32 pins must be connected to a 32.768 kHz crystal. Two external capacitors must be wired as shown in [Figure 23-3](#).

Figure 23-3. Typical Slow Clock Oscillator Connection

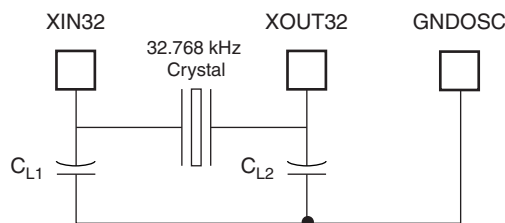

23.4.4.2 Slow Clock Oscillator Startup Time

The startup time of the Slow Clock Oscillator is given in the DC Characteristics section of the product datasheet. As it is often higher than 500 ms and the processor requires an assertion of the reset until it has stabilized, the user must implement an external reset supervisor covering this startup time. However, this startup is only required in case of cold reset, i.e., in case of system power-up. When a warm reset occurs, the length of the reset pulse may be much lower. For further details, see [Section 15. "AT91RM9200 Reset Controller" on page 117](#).

23.4.5 Main Oscillator

Figure 23-4 shows the Main Oscillator block diagram.

Figure 23-4. Main Oscillator Block Diagram

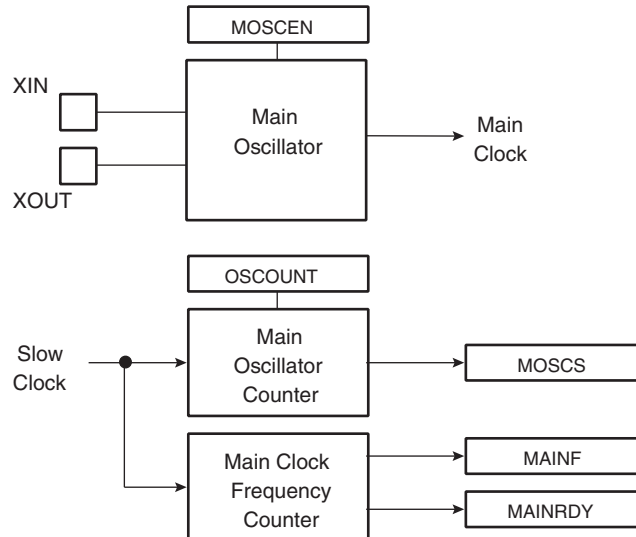

23.4.5.1 Main Oscillator Connections

The Clock Generator integrates a Main Oscillator that is designed for a 3 to 20 MHz fundamental crystal. The typical crystal connection is illustrated in Figure 23-5. The 1 k Ω resistor is only required for crystals with frequencies lower than 8 MHz. The oscillator contains internal capacitors on each XIN and XOUT pin. For further details on the electrical characteristics of the Main Oscillator, see the section “AT91RM9200 Electrical Characteristics”.

Figure 23-5. Typical Crystal Connection

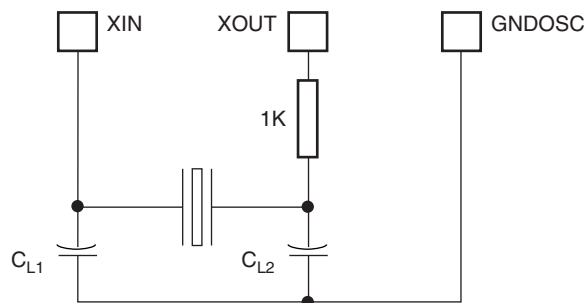

23.4.5.2 Main Oscillator Startup Time

The startup time of the Main Oscillator is given in the DC Characteristics section of the product datasheet. The startup time depends on the crystal frequency and decreases when the frequency rises.

23.4.5.3 Main Oscillator Control

To minimize the power required to start up the system, the Main Oscillator is disabled after reset and the Slow Clock mode is selected.

The software enables or disables the Main Oscillator so as to reduce power consumption by clearing the MOSCEN bit in the Main Oscillator Register (CKGR_MOR). When disabling the Main Oscillator by clearing the MOSCEN bit in CKGR_MOR, the MOSCS bit in PMC_SR is automatically cleared indicating the Main Clock is off.

When enabling the Main Oscillator, the user must initiate the Main Oscillator counter with a value corresponding to the startup time of the oscillator. This startup time depends on the crystal frequency connected to the main oscillator. When the MOSCEN bit and the OSCOUNT are written in CKGR_MOR to enable the Main Oscillator, the MOSCS bit is cleared and the counter starts counting down on Slow Clock from the OSCOUNT value. Since the OSCOUNT value is coded with 8 bits, the maximum startup time is about 62 ms.

When the counter reaches 0, the MOSCS bit is set, indicating that the Main Clock is valid. Setting the MOSCS bit in PMC_IMR can trigger an interrupt to the processor on this event.

23.4.5.4 *Main Clock Frequency Counter*

The Main Oscillator features a Main Clock frequency counter that provides the quartz frequency connected to the Main Oscillator. Generally, this value is known by the system designer; however, it is useful for the boot program to configure the device with the correct clock speed, independently of the application.

The Main Clock frequency counter starts incrementing at the Main Clock speed after the next rising edge of the Slow Clock as soon as the Main Oscillator is stable, i.e., as soon as the MOSCS bit is set. Then, at the 16th falling edge of Slow Clock, the bit MAINRDY in CKGR_MCFR (Main Clock Frequency Register) is set and the counter stops counting. Its value can be read in the MAINF field of CKGR_MCFR and gives the number of Main Clock cycles during 16 periods of Slow Clock, so that the frequency of the crystal connected on the Main Oscillator can be determined.

23.4.5.5 *Main Oscillator Bypass*

The user can input a clock on the device instead of connecting a crystal. In this case, the user has to provide the external clock signal on the pin XIN. The input characteristics of the XIN pin under these conditions are given in the product Electrical Characteristics section. The programmer has to be sure not to modify the MOSCEN bit in the Main Oscillator Register (CKGR_MOR). This bit must remain at 0, its reset value, for the external clock to operate properly. While this bit is at 0, the pin XIN is pulled down by a 500 k Ω resistor in parallel with a 40 pF capacitor.

The external clock signal must meet the requirements relating to the power supply VDDPLL (i.e., between 1.65V and 1.95V) and cannot exceed 50 MHz.

23.4.6 Divider and PLL Blocks

The Clock Generator features two Divider/PLL Blocks that generates a wide range of frequencies. Additionally, they provide a 48 MHz signal to the embedded USB device and/or host ports, regardless of the frequency of the Main Clock.

Figure 23-6 shows the block diagram of the divider and PLL blocks.

Figure 23-6. Divider and PLL Blocks Block Diagram

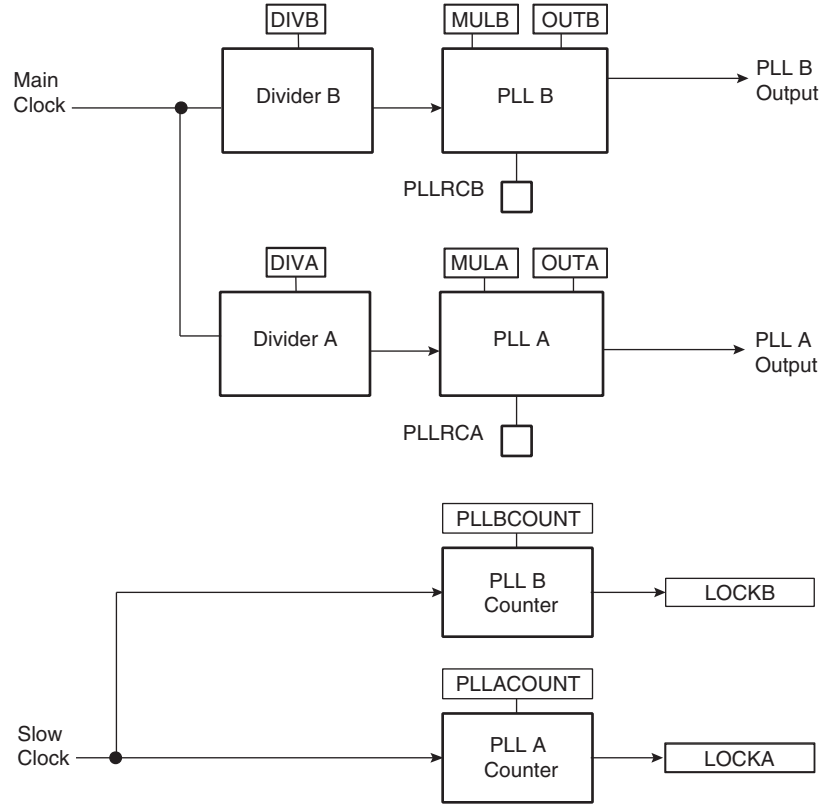

23.4.6.1 PLL Filters

The two PLLs require connection to an external second-order filter through the pins PLLRC. Figure 23-7 shows a schematic of these filters.

Figure 23-7. PLL Capacitors and Resistors

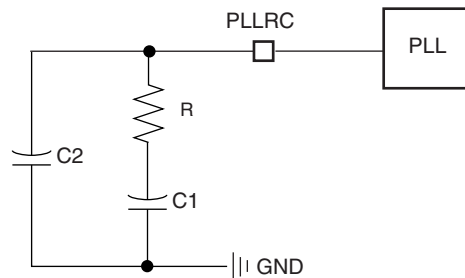

Values of R, C1 and C2 to be connected to the PLLRC pins must be calculated as a function of the PLL input frequency, the PLL output frequency and the phase margin. A trade-off has to be found between output signal overshoot and startup time.

23.4.6.2 PLL Source Clock

The source of PLLs A and B is respectively the output of Divider A, i.e. the Main Clock divided by DIVA, and the output of Divider B, i.e. the Main Clock divided by DIVB.

As the input frequency of the PLLs is limited, the user has to make sure that the programming of DIVA and DIVB are compliant with the input frequency range of the PLLs, which is given in the DC Characteristics section of the product datasheet.

23.4.6.3 Divider and Phase Lock Loop Programming

The two dividers increase the accuracy of the PLLA and the PLLB clocks independently of the input frequency.

The Main Clock can be divided by programming the DIVB field in CKGR_PLLBR and the DIVA field in CKGR_PLLAR. Each divider can be set between 1 and 255 in steps of 1. When the DIVA and DIVB fields are set to 0, the output of the divider and the PLL outputs A and B are a continuous signal at level 0. On reset, the DIVA and DIVB fields are set to 0, thus both PLL input clocks are set to 0.

The two PLLs of the clock generator allow multiplication of the divider's outputs. The PLLA and the PLLB clock signals have a frequency that depends on the respective source signal frequency and on the parameters DIV (DIVA, DIVB) and MUL (MULA, MULB). The factor applied to the source signal frequency is $(MUL + 1)/DIV$. When MULA or MULB is written to 0, the corresponding PLL is disabled and its power consumption is saved. Re-enabling the PLLA or the PLLB can be performed by writing a value higher than 0 in the MULA or MULB field, respectively.

Whenever a PLL is re-enabled or one of its parameters is changed, the LOCKA or LOCKB bit in PMC_SR is automatically cleared. The values written in the PLLACOUNT or PLLBCOUNT fields in CKGR_PPLAR and CKGR_PLLBR, respectively, are loaded in the corresponding PLL counter. The PLL counter then decrements at the speed of the Slow Clock until it reaches 0. At this time, the corresponding LOCK bit is set in PMC_SR and can trigger an interrupt to the processor. The user has to load the number of Slow Clock cycles required to cover the PLL transient time into the PLLACOUNT and PLLBCOUNT field. The transient time depends on the PLL filters. The initial state of the PLL and its target frequency can be calculated using a specific tool provided by Atmel.

23.4.6.4 PLLB Divider by 2

In ARM9-based systems, the PLLB clock may be divided by two. This divider can be enabled by setting the bit USB_96M of CKGR_PLLBR. In this case, the divider by 2 is enabled and the PLLB must be programmed to output 96 MHz and not 48 MHz, thus ensuring correct operation of the USB bus.

23.4.7 Clock Controllers

The Power Management Controller provides the clocks to the different peripherals of the system, either internal or external. It embeds the following elements:

- the Master Clock Controller, which selects the Master Clock.
- the Processor Clock Controller, which implements the Idle Mode.
- the Peripheral Clock Controller, which provides power saving by controlling clocks of the embedded peripherals.
- the USB Clock Controller, which distributes the 48 MHz clock to the USB controllers.
- the Programmable Clock Controller, which allows generation of up to four programmable clock signals on external pins.

23.4.7.1 Master Clock Controller

The Master Clock Controller provides selection and division of the Master Clock (MCK). MCK is the clock provided to all the peripherals and the memory controller.

The Master Clock is selected from one of the clocks provided by the Clock Generator. Selecting the Slow Clock enables Slow Clock Mode by providing a 32.768 kHz signal to the whole device. Selecting the Main Clock saves power consumption of both PLLs, but prevents using the USB ports. Selecting the PLLB Clock saves the power consumption of the PLLA by running the processor and the peripheral at 48 MHz required by the USB ports. Selecting the PLLA Clock runs the processor and the peripherals at their maximum speed while running the USB ports at 48 MHz.

The Master Clock Controller is made up of a clock selector and a prescaler, as shown in [Figure 23-8](#). It also contains an optional Master Clock divider in products integrating an ARM9 processor. This allows the processor clock to be faster than the Master Clock.

The Master Clock selection is made by writing the CSS field (Clock Source Selection) in PMC_MCKR (Master Clock Register). The prescaler supports the division by a power of 2 of the selected clock between 1 and 64. The PRES field in PMC_MCKR programs the prescaler.

When the Master Clock divider is implemented, it can be programmed between 1 and 4 through the MDIV field in PMC_MCKR.

Each time PMC_MCKR is written to define a new Master Clock, the MCKRDY bit is cleared in PMC_SR. It reads 0 until the Master Clock is established. Then, the MCKRDY bit is set and can trigger an interrupt to the processor. This feature is useful when switching from a high-speed clock to a lower one to inform the software when the change is actually done.

Note: A new value to be written in PMC_MCKR must not be the same as the current value in PMC_MCKR.

Figure 23-8. Master Clock Controller

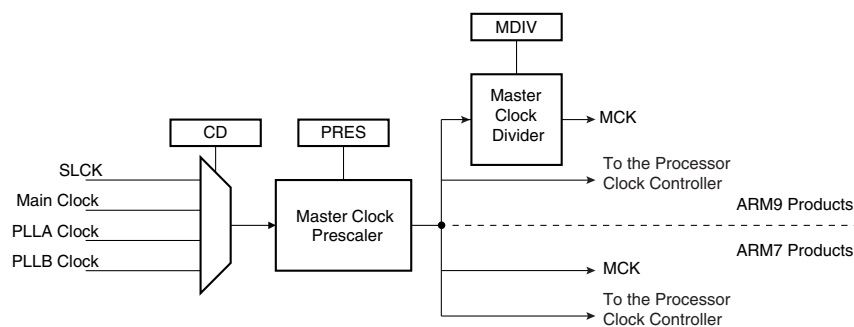

23.4.7.2 Processor Clock Controller

The PMC features a Processor Clock Controller that implements the Idle Mode. The Processor Clock can be enabled and disabled by writing the System Clock Enable (PMC_SCER) and System Clock Disable Registers (PMC_SCDR). The status of this clock (at least for debug purpose) can be read in the System Clock Status Register (PMC_SCSR).

Processor Clock Source

The clock provided to the processor is determined by the Master Clock controller. On ARM7-based systems, the Processor Clock source is directly the Master Clock.

On ARM9-based systems, the Processor Clock source might be 2, 3 or 4 times the Master Clock. This ratio value is determined by programming the field MDIV of the Master Clock Register (PMC_MCKR).

Idle Mode

The Processor Clock is enabled after a reset and is automatically re-enabled by any enabled interrupt. The Idle Mode is achieved by disabling the Processor Clock, which is automatically re-enabled by any enabled fast or normal interrupt, or by the reset of the product.

When the Processor Clock is disabled, the current instruction is finished before the clock is stopped, but this does not prevent data transfers from other masters of the system bus.

23.4.7.3 Peripheral Clock Controller

The PMC controls the clocks of each embedded peripheral. The user can individually enable and disable the Master Clock on the peripherals by writing into the Peripheral Clock Enable (PMC_PCER) and Peripheral Clock Disable (PMC_PCDR) registers. The status of the peripheral clock activity can be read in the Peripheral Clock Status Register (PMC_PCSR).

When a peripheral clock is disabled, the clock is immediately stopped. When the clock is re-enabled, the peripheral resumes action where it left off. The peripheral clocks are automatically disabled after a reset.

In order to stop a peripheral, it is recommended that the system software wait until the peripheral has executed its last programmed operation before disabling the clock. This is to avoid data corruption or erroneous behavior of the system.

The bit number within the Peripheral Clock Control registers (PMC_PCER, PMC_PCDR, and PMC_PCSR) is the Peripheral Identifier defined at the product level. Generally, the bit number corresponds to the interrupt source number assigned to the peripheral.

23.4.7.4 USB Clock Controller

If using one of the USB ports, the user has to program the Divider and PLL B block to output a 48 MHz signal with an accuracy of $\pm 0.25\%$.

When the clock for the USB is stable, the USB device and host clocks, UDPCK and UHPCK, can be enabled. They can be disabled when the USB transactions are finished, so that the power consumption generated by the 48 MHz signal on these peripherals is saved.

The USB ports require both the 48 MHz signal and the Master Clock. The Master Clock may be controlled via the Peripheral Clock Controller.

USB Device Clock Control

The USB Device Port clock UDPCK can be enabled by writing 1 at the UDP bit in PMC_SCER (System Clock Enable Register) and disabled by writing 1 at the bit UDP in PMC_SCDR (System Clock Disable Register). The activity of UDPCK is shown in the bit UDP of PMC_SCSR (System Clock Status Register).

USB Device Port Suspend

When the USB Device Port detects a suspend condition, the 48 MHz clock is automatically disabled, i.e., the UDP bit in PMC_SCSR is cleared. It is also possible to automatically disable the Master Clock provided to the USB Device Port on a suspend condition. The MCKUDP bit in PMC_SCSR configures this feature and can be set or cleared by writing one in the same bit of PMC_SCER and PMC_SCDR.

USB Host Clock Control

The USB Host Port clock UHPCK can be enabled by writing 1 at the UHP bit in PMC_SCER (System Clock Enable Register) and disabled by writing 1 at the UHP bit in PMC_SCDR (System Clock Disable Register). The activity of UDPCK is shown in the bit UHP of PMC_SCSR (System Clock Status Register).

23.4.7.5 Programmable Clock Output Controller

The PMC controls up to four signals to be output on external pins PCK0 to PCK3. Each signal can be independently programmed via the registers PMC_PCK0 to PMC_PCK3.

PCK0 to PCK3 can be independently selected between the four clocks provided by the Clock Generator by writing the CSS field in PMC_PCK0 to PMC_PCK3. Each output signal can also be divided by a power of 2 between 1 and 64 by writing the field PRES (Prescaler) in PMC_PCK0 to PMC_PCK3.

Each output signal can be enabled and disabled by writing 1 in the corresponding bit PCK0 to PCK3 of PMC_SCER and PMC_SCDR, respectively. Status of the active programmable output clocks are given in the bits PCK0 to PCK3 of PMC_SCSR (System Clock Status Register).

Moreover, like the MCK, a status bit in PMC_SR indicates that the Programmable Clock is actually what has been programmed in the Programmable Clock registers.

As the Programmable Clock Controller does not manage with glitch prevention when switching clocks, it is strongly recommended to disable the Programmable Clock before any configuration change and to re-enable it after the change is actually performed.

Note also that it is required to assign the pin to the Programmable Clock operation in the PIO Controller to enable the signal to be driven on the pin.

23.5 Clock Switching Details

23.5.1 Master Clock Switching Timings

Table 23-1 gives the worst case timing required for the Master Clock to switch from one selected clock to another one. This is in the event that the prescaler is de-activated. When the prescaler is activated, an additional time of 64 clock cycles of the new selected clock has to be added.

Table 23-1. Clock Switching Timings (Worst Case)

To	From	Main Clock	SLCK	PLLA Clock	PLLB Clock
Main Clock		–	4 x SLCK + 2.5 x Main Clock	3 x PLLA Clock + 4 x SLCK + 1 x Main Clock	3 x PLLB Clock + 4 x SLCK + 1 x Main Clock
SLCK		0.5 x Main Clock + 4.5 x SLCK	–	3 x PLLA Clock + 5 x SLCK	3 x PLLB Clock + 5 x SLCK
PLLA Clock		0.5 x Main Clock + 4 x SLCK + PLLACOUNT x SLCK + 2.5 x PLLA Clock	2.5 x PLLA Clock + 5 x SLCK + PLLACOUNT x SLCK	2.5 x PLLA Clock + 4 x SLCK + PLLBCOUNT x SLCK	3 x PLLA Clock + 4 x SLCK + 1.5 x PLLA Clock
PLLB Clock		0.5 x Main Clock + 4 x SLCK + PLLBCOUNT x SLCK + 2.5 x PLLB Clock	2.5 x PLLB Clock + 5 x SLCK + PLLBCOUNT x SLCK	3 x PLLB Clock + 4 x SLCK + 1.5 x PLLB Clock	2.5 x PLLB Clock + 4 x SLCK + PLLACOUNT x SLCK

23.5.2 Clock Switching Waveforms

Figure 23-9. Switch Master Clock from Slow Clock to PLLA Clock

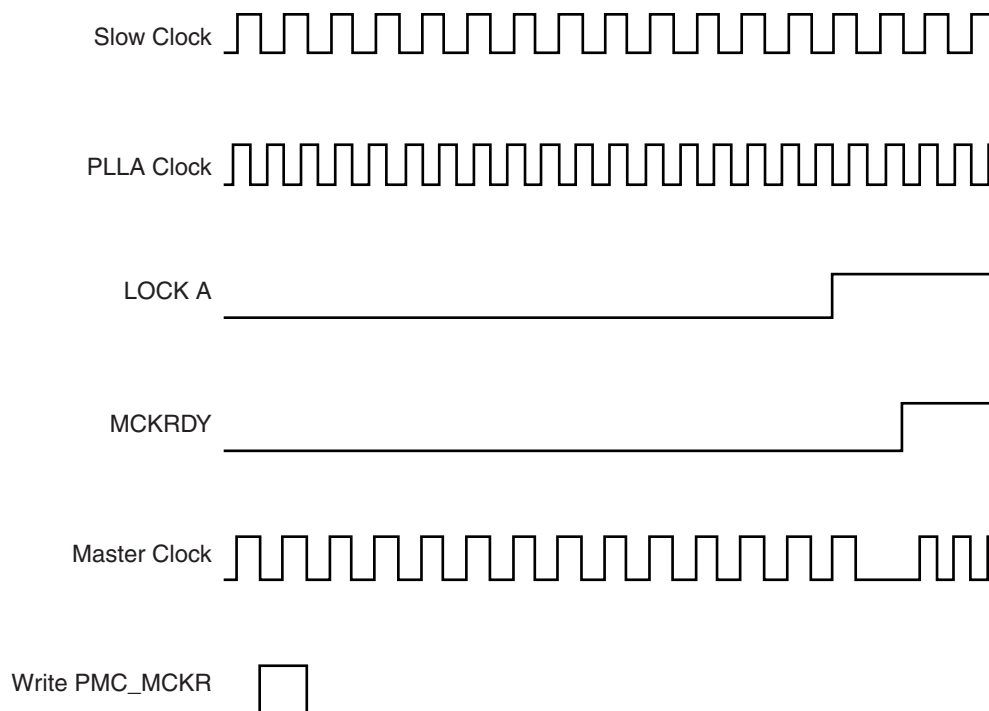

Figure 23-10. Switch Master Clock from Main Clock to Slow Clock

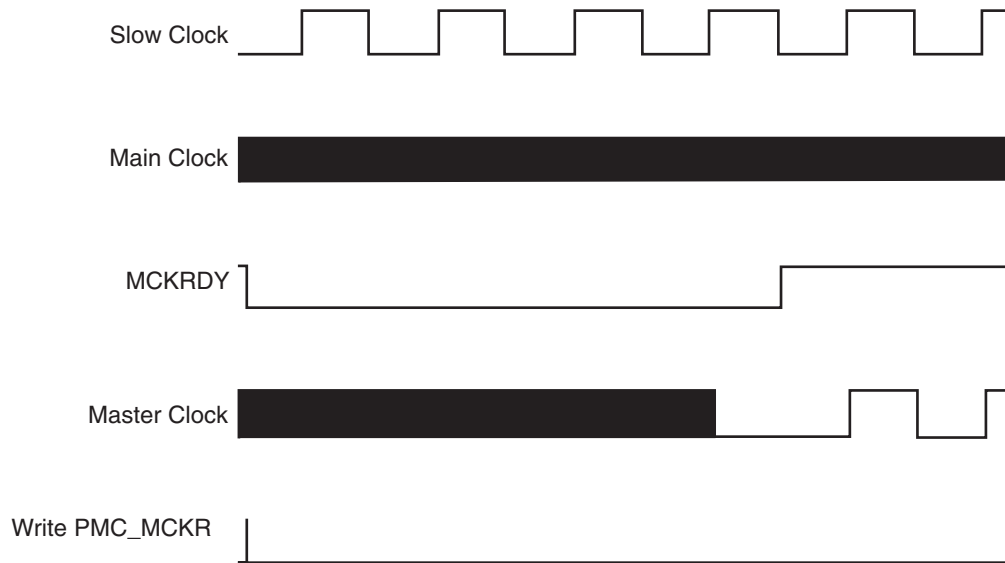

Figure 23-11. Change PLLA Programming

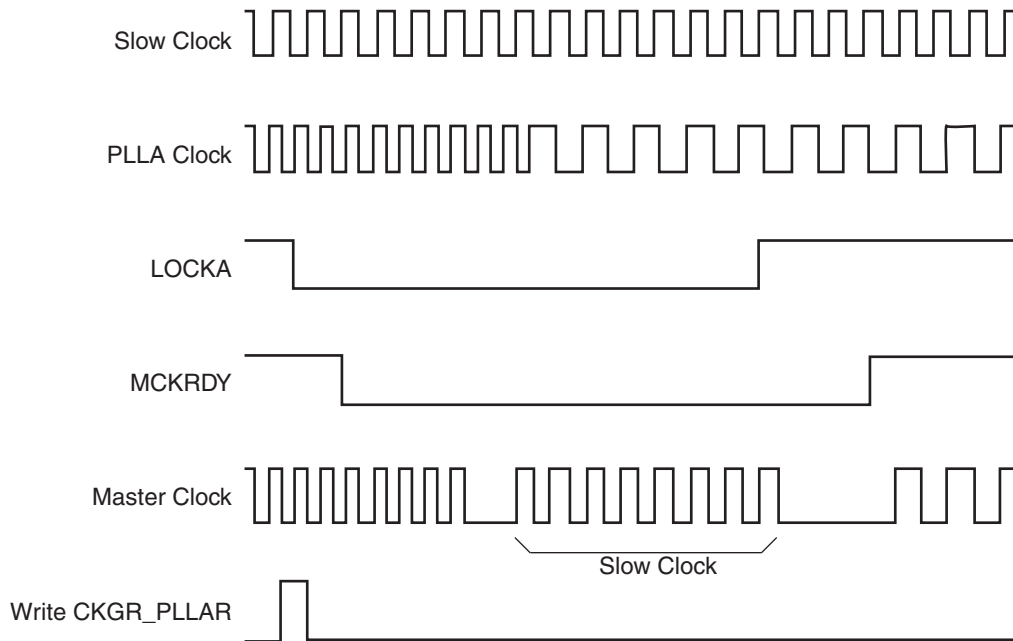
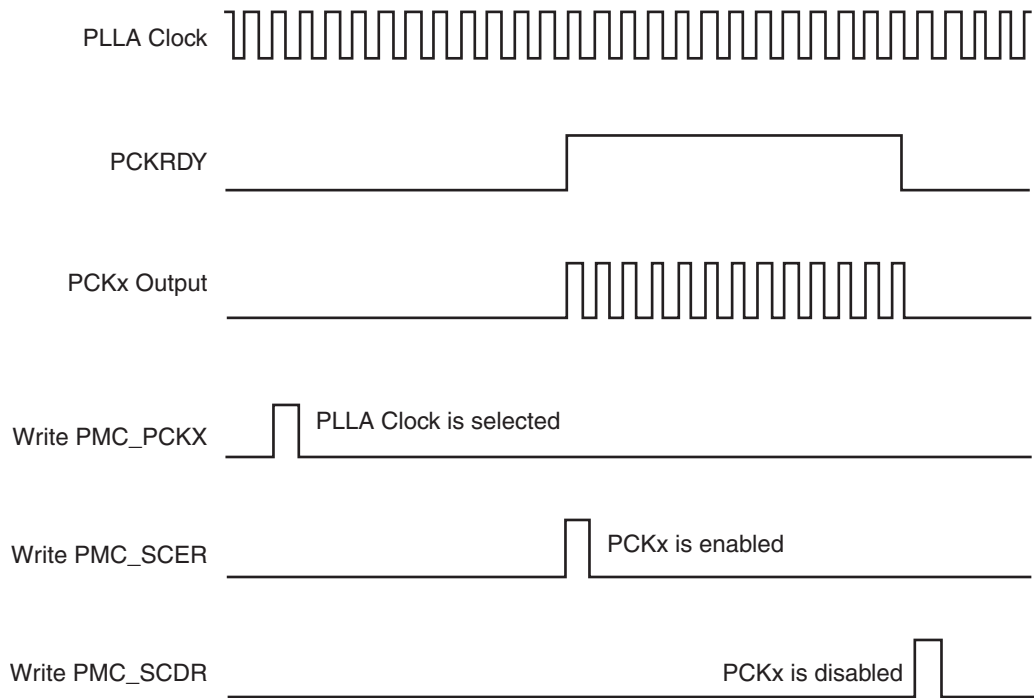

Figure 23-12. Programmable Clock Output Programming



23.6 Power Management Controller (PMC) User Interface

Table 23-2. Register Mapping

Offset	Register	Name	Access	Reset Value
0x0000	System Clock Enable Register	PMC_SCER	Write-only	–
0x0004	System Clock Disable Register	PMC_SCDR	Write-only	–
0x0008	System Clock Status Register	PMC_SCSR	Read-only	0x01
0x000C	Reserved	–	–	–
0x0010	Peripheral Clock Enable Register	PMC_PCER	Write-only	–
0x0014	Peripheral Clock Disable Register	PMC_PCDR	Write-only	–
0x0018	Peripheral Clock Status Register	PMC_PCSR	Read-only	0x0
0x001C	Reserved	–	–	–
0x0020	Main Oscillator Register	CKGR_MOR	ReadWrite	0x0
0x0024	Main Clock Frequency Register	CKGR_MCFR	Read-only	-
0x0028	PLL A Register	CKGR_PLLAR	ReadWrite	0x3F00
0x002C	PLL B Register	CKGR_PLLBR	ReadWrite	0x3F00
0x0030	Master Clock Register	PMC_MCKR	Read/Write	0x00
0x0034	Reserved	–	–	–
0x0038	Reserved	–	–	–
0x003C	Reserved	–	–	–
0x0040	Programmable Clock 0 Register	PMC_PCK0	Read/Write	0x0
0x0044	Programmable Clock 1 Register	PMC_PCK1	Read/Write	0x0
0x0048	Programmable Clock 2 Register	PMC_PCK2	Read/Write	0x0
0x004C	Programmable Clock 3 Register	PMC_PCK3	Read/Write	0x0
0x0050	Reserved	–	–	–
0x0054	Reserved	–	–	–
0x0058	Reserved	–	–	–
0x005C	Reserved	–	–	–
0x0060	Interrupt Enable Register	PMC_IER	Write-only	--
0x0064	Interrupt Disable Register	PMC_IDR	Write-only	--
0x0068	Status Register	PMC_SR	Read-only	--
0x006C	Interrupt Mask Register	PMC_IMR	Read-only	0x0

23.6.1 PMC System Clock Enable Register

Register Name: PMC_SCER

Access Type: Write-only

31	30	29	28	27	26	25	24
–	–	–	–	–	–	–	–
23	22	21	20	19	18	17	16
–	–	–	–	–	–	–	–
15	14	13	12	11	10	9	8
–	–	–	–	PCK3	PCK2	PCK1	PCK0
7	6	5	4	3	2	1	0
–	–	–	UHP	–	MCKUDP	UDP	PCK

- **PCK: Processor Clock Enable**

0 = No effect.

1 = Enables the Processor Clock.

- **UDP: USB Device Port Clock Enable**

0 = No effect.

1 = Enables the 48 MHz clock of the USB Device Port.

- **MCKUDP: USB Device Port Master Clock Automatic Disable on Suspend Enable**

0 = No effect.

1 = Enables the automatic disable of the Master Clock of the USB Device Port when a suspend condition occurs.

- **UHP: USB Host Port Clock Enable**

0 = No effect.

1 = Enables the 48 MHz clock of the USB Host Port.

- **PCK0...PCK3: Programmable Clock Output Enable**

0 = No effect.

1 = Enables the corresponding Programmable Clock output.

23.6.2 PMC System Clock Disable Register

Register Name: PMC_SCDR

Access Type: Write-only

31	30	29	28	27	26	25	24
–	–	–	–	–	–	–	–
23	22	21	20	19	18	17	16
–	–	–	–	–	–	–	–
15	14	13	12	11	10	9	8
–	–	–	–	PCK3	PCK2	PCK1	PCK0
7	6	5	4	3	2	1	0
–	–	–	UHP	–	MCKUDP	UDP	PCK

- **PCK: Processor Clock Disable**

0 = No effect.

1 = Disables the Processor Clock.

- **UDP: USB Device Port Clock Disable**

0 = No effect.

1 = Disables the 48 MHz clock of the USB Device Port.

- **MCKUDP: USB Device Port Master Clock Automatic Disable on Suspend Disable**

0 = No effect.

1 = Disables the automatic disable of the Master Clock of the USB Device Port when a suspend condition occurs.

- **UHP: USB Host Port Clock Disable**

0 = No effect.

1 = Disables the 48 MHz clock of the USB Host Port.

- **PCK0...PCK3: Programmable Clock Output Disable**

0 = No effect.

1 = Disables the corresponding Programmable Clock output.

23.6.3 PMC System Clock Status Register

Register Name: PMC_SCSR

Access Type: Read-only

31	30	29	28	27	26	25	24
–	–	–	–	–	–	–	–
23	22	21	20	19	18	17	16
–	–	–	–	–	–	–	–
15	14	13	12	11	10	9	8
–	–	–	–	PCK3	PCK2	PCK1	PCK0
7	6	5	4	3	2	1	0
–	–	–	UHP	–	MCKUDP	UDP	PCK

- **PCK: Processor Clock Status**

0 = The Processor Clock is disabled.

1 = The Processor Clock is enabled.

- **UDP: USB Device Port Clock Status**

0 = The 48 MHz clock of the USB Device Port is disabled.

1 = The 48 MHz clock of the USB Device Port is enabled.

- **MCKUDP: USB Device Port Master Clock Automatic Disable on Suspend Status**

0 = The automatic disable of the Master clock of the USB Device Port when suspend condition occurs is disabled.

1 = The automatic disable of the Master clock of the USB Device Port when suspend condition occurs is enabled.

- **UHP: USB Host Port Clock Status**

0 = The 48 MHz clock of the USB Host Port is disabled.

1 = The 48 MHz clock of the USB Host Port is enabled.

- **PCK0...PCK3: Programmable Clock Output Status**

0 = The corresponding Programmable Clock output is disabled.

1 = The corresponding Programmable Clock output is enabled.

23.6.4 PMC Peripheral Clock Enable Register

Register Name: PMC_PCER

Access Type: Write-only

31	30	29	28	27	26	25	24
PID31	PID30	PID29	PID28	PID27	PID26	PID25	PID24
23	22	21	20	19	18	17	16
PID23	PID22	PID21	PID20	PID19	PID18	PID17	PID16
15	14	13	12	11	10	9	8
PID15	PID14	PID13	PID12	PID11	PID10	PID9	PID8
7	6	5	4	3	2	1	0
PID7	PID6	PID5	PID4	PID3	PID2	–	–

- **PID2...PID31: Peripheral Clock Enable**

0 = No effect.

1 = Enables the corresponding peripheral clock.

23.6.5 PMC Peripheral Clock Disable Register

Register Name: PMC_PCDR

Access Type: Write-only

31	30	29	28	27	26	25	24
PID31	PID30	PID29	PID28	PID27	PID26	PID25	PID24
23	22	21	20	19	18	17	16
PID23	PID22	PID21	PID20	PID19	PID18	PID17	PID16
15	14	13	12	11	10	9	8
PID15	PID14	PID13	PID12	PID11	PID10	PID9	PID8
7	6	5	4	3	2	1	0
PID7	PID6	PID5	PID4	PID3	PID2	–	–

- **PID2...PID31: Peripheral Clock Disable**

0 = No effect.

1 = Disables the corresponding peripheral clock.

23.6.6 PMC Peripheral Clock Status Register

Register Name: PMC_PCSR

Access Type: Read-only

31	30	29	28	27	26	25	24
PID31	PID30	PID29	PID28	PID27	PID26	PID25	PID24
23	22	21	20	19	18	17	16
PID23	PID22	PID21	PID20	PID19	PID18	PID17	PID16
15	14	13	12	11	10	9	8
PID15	PID14	PID13	PID12	PID11	PID10	PID9	PID8
7	6	5	4	3	2	1	0
PID7	PID6	PID5	PID4	PID3	PID2	–	–

- **PID2...PID31: Peripheral Clock Status**

0 = The corresponding peripheral clock is disabled.

1 = The corresponding peripheral clock is enabled.

23.6.7 PMC Clock Generator Main Oscillator Register

Register Name: CKGR_MOR

Access Type: Read/Write

31	30	29	28	27	26	25	24
–	–	–	–	–	–	–	–
23	22	21	20	19	18	17	16
–	–	–	–	–	–	–	–
15	14	13	12	11	10	9	8
OSCOUNTER							
7	6	5	4	3	2	1	0
–	–	–	–	–	–	OSCBYPASS	MOSCEN

- **MOSCEN: Main Oscillator Enable**

A crystal must be connected between XIN and XOUT.

0 = The Main Oscillator is disabled.

1 = The Main Oscillator is enabled. OSCBYPASS must be set to 0.

When MOSCEN is set, the MOSCS flag is set once the Main Oscillator startup time is achieved.

- **OSCBYPASS: Oscillator Bypass**

0 = No effect.

1 = The Main Oscillator is bypassed. MOSCEN must be set to 0. An external clock must be connected on XIN.

When OSCBYPASS is set, the MOSCS flag in PMC_SR is automatically set.

Clearing MOSCEN and OSCBYPASS bits allows resetting the MOSCS flag.

- **OSCOUNTER: Main Oscillator Start-up Time**

Specifies the number of Slow Clock cycles multiplied by 8 for the Main Oscillator start-up time.

23.6.8 PMC Clock Generator Main Clock Frequency Register

Register Name: CKGR_MCFR

Access Type: Read-only

31	30	29	28	27	26	25	24
–	–	–	–	–	–	–	–
23	22	21	20	19	18	17	16
–	–	–	–	–	–	–	MAINRDY
15	14	13	12	11	10	9	8
MAINF							
7	6	5	4	3	2	1	0
MAINF							

- **MAINF: Main Clock Frequency**

Gives the number of Main Clock cycles within 16 Slow Clock periods.

- **MAINRDY: Main Clock Ready**

0 = MAINF value is not valid or the Main Oscillator is disabled.

1 = The Main Oscillator has been enabled previously and MAINF value is available.

23.6.9 PMC Clock Generator PLL A Register

Register Name: CKGR_PLLAR

Access Type: Read/Write

31	30	29	28	27	26	25	24
-	-	1	-	-	MULA		
23	22	21	20	19	18	17	16
MULA							
15	14	13	12	11	10	9	8
OUTA		PLLACOUNT					
7	6	5	4	3	2	1	0
DIVA							

Possible limitations on PLL A input frequencies and multiplier factors should be checked before using the Clock Generator. Value to be written in CKGR_PLLAR must not be the same as current value in CKGR_PLLAR.

- DIVA: Divider A**

DIVA	Divider Selected
0	Divider output is 0
1	Divider is bypassed
2 - 255	Divider output is the Main Clock divided by DIVA.

- PLLACOUNT: PLL A Counter**

Specifies the number of Slow Clock cycles before the LOCKA bit is set in PMC_SR after CKGR_PLLAR is written.

- OUTA: PLL A Clock Frequency Range**

OUTA		PLL A Frequency Output Range
0	0	80 MHz to 160 MHz
0	1	Reserved
1	0	150 MHz to 180 MHz
1	1	Reserved

- MULA: PLL A Multiplier**

0 = The PLL A is deactivated.

1 up to 2047 = The PLL A Clock frequency is the PLL A input frequency multiplied by MULA + 1.

23.6.10 PMC Clock Generator PLL B Register

Register Name: CKGR_PLLBR

Access Type: Read/Write

31	30	29	28	27	26	25	24
–	–	–	USB_96M	–	MULB		
23	22	21	20	19	18	17	16
MULB							
15	14	13	12	11	10	9	8
OUTB		PLLBCOUNT					
7	6	5	4	3	2	1	0
DIVB							

Possible limitations on PLL B input frequencies and multiplier factors should be checked before using the Clock Generator. Value to be written in CKGR_PLLBR must not be the same as current value in CKGR_PLLBR.

- **DIVB: Divider B**

DIVB	Divider Selected
0	Divider output is 0
1	Divider is bypassed
2 - 255	Divider output is the selected clock divided by DIVB.

- **PLLBCOUNT: PLL B Counter**

Specifies the number of slow clock cycles before the LOCKB bit is set in PMC_SR after CKGR_PLLBR is written.

- **OUTB: PLL B Clock Frequency Range**

OUTB		PLL B Clock Frequency Range
0	0	80 MHz to 160 MHz
0	1	Reserved
1	0	150 MHz to 180 MHz
1	1	Reserved

- **MULB: PLL B Multiplier**

0 = The PLL B is deactivated.

1 up to 2047 = The PLL B Clock frequency is the PLL B input frequency multiplied by MULB + 1.

- **USB_96M: Divider by 2 Enable (only on ARM9-based Systems)**

0 = USB ports clocks are PLL B Clock, therefore the PMC Clock Generator must be programmed for the PLL B Clock to be 48 MHz.

1 = USB ports clocks are PLL B Clock divided by 2, therefore the PMC Clock Generator must be programmed for the PLL B Clock to be 96 MHz.

23.6.11 PMC Master Clock Register

Register Name: PMC_MCKR

Access Type: Read/Write

31	30	29	28	27	26	25	24
–	–	–	–	–	–	–	–
23	22	21	20	19	18	17	16
–	–	–	–	–	–	–	–
15	14	13	12	11	10	9	8
–	–	–	–	–	–	MDIV	
7	6	5	4	3	2	1	0
–	–		PRES			CSS	

Note: Value to be written in PMC_MCKR must not be the same as current value in PMC_MCKR.

- **CSS: Master Clock Selection**

CSS		Clock Source Selection
0	0	Slow Clock is selected
0	1	Main Clock is selected
1	0	PLL A Clock is selected
1	1	PLL B Clock is selected

- **PRES: Master Clock Prescaler**

PRES			Master Clock
0	0	0	Selected clock
0	0	1	Selected clock divided by 2
0	1	0	Selected clock divided by 4
0	1	1	Selected clock divided by 8
1	0	0	Selected clock divided by 16
1	0	1	Selected clock divided by 32
1	1	0	Selected clock divided by 64
1	1	1	Reserved

- **MDIV: Master Clock Division (on ARM9-based systems only)**

0 = The Master Clock and the Processor Clock are the same.

1 = The Processor Clock is twice as fast as the Master Clock.

2 = The Processor Clock is three times faster than the Master Clock.

3 = The Processor Clock is four times faster than the Master Clock.

23.6.12 PMC Programmable Clock Register 0 to 3

Register Name: PMC_PCK0..PMC_PCK3

Access Type: Read/Write

31	30	29	28	27	26	25	24
–	–	–	–	–	–	–	–
23	22	21	20	19	18	17	16
–	–	–	–	–	–	–	–
15	14	13	12	11	10	9	8
–	–	–	–	–	–	–	–
7	6	5	4	3	2	1	0
–	–	–	PRES			CSS	

- **CSS: Master Clock Selection**

CSS		Clock Source Selection
0	0	Slow Clock is selected
0	1	Main Clock is selected
1	0	PLL A Clock is selected
1	1	PLL B Clock is selected

- **PRES: Programmable Clock Prescaler**

PRES			Master Clock
0	0	0	Selected clock
0	0	1	Selected clock divided by 2
0	1	0	Selected clock divided by 4
0	1	1	Selected clock divided by 8
1	0	0	Selected clock divided by 16
1	0	1	Selected clock divided by 32
1	1	0	Selected clock divided by 64
1	1	1	Reserved

23.6.13 PMC Interrupt Enable Register

Register Name: PMC_IER

Access Type: Write-only

31	30	29	28	27	26	25	24
–	–	–	–	–	–	–	–
23	22	21	20	19	18	17	16
–	–	–	–	–	–	–	–
15	14	13	12	11	10	9	8
–	–	–	–	PCK3RDY	PCK2RDY	PCK1RDY	PCK0RDY
7	6	5	4	3	2	1	0
–	–	–	–	MCKRDY	LOCKB	LOCKA	MOSCS

- **MOSCS: Main Oscillator Status**
- **LOCKA: PLL A Lock**
- **LOCKB: PLL B Lock**
- **MCKRDY: Master Clock Ready**
- **PCK0RDY - PCK3RDY: Programmable Clock Ready**

0 = No effect.

1 = Enables the corresponding interrupt.

23.6.14 PMC Interrupt Disable Register

Register Name: PMC_IDR

Access Type: Write-only

31	30	29	28	27	26	25	24
–	–	–	–	–	–	–	–
23	22	21	20	19	18	17	16
–	–	–	–	–	–	–	–
15	14	13	12	11	10	9	8
–	–	–	–	PCK3RDY	PCK2RDY	PCK1RDY	PCK0RDY
7	6	5	4	3	2	1	0
–	–	–	–	MCKRDY	LOCKB	LOCKA	MOSCS

- **MOSCS: Main Oscillator Status**
- **LOCKA: PLL A Lock**
- **LOCKB: PLL B Lock**
- **MCKRDY: Master Clock Ready**
- **PCK0RDY - PCK3RDY: Programmable Clock Ready**

0 = No effect.

1 = Disables the corresponding interrupt.

23.6.15 PMC Status Register

Register Name: PMC_SR

Access Type: Read-only

31	30	29	28	27	26	25	24
–	–	–	–	–	–	–	–
23	22	21	20	19	18	17	16
–	–	–	–	–	–	–	–
15	14	13	12	11	10	9	8
–	–	–	–	PCK3RDY	PCK2RDY	PCK1RDY	PCK0RDY
7	6	5	4	3	2	1	0
–	–	–	–	MCKRDY	LOCKB	LOCKA	MOSCS

- **MOSCS: MOSCS Flag Status**

0 = Main oscillator is not stabilized.

1 = Main oscillator is stabilized.

- **LOCKA: PLLA Lock Status**

0 = PLL A is not locked

1 = PLL A is locked.

- **LOCKB: PLLB Lock Status**

0 = PLL B is not locked.

1 = PLL B is locked.

- **MCKRDY: Master Clock Status**

0 = MCK is not ready.

1 = MCK is ready.

- **PCK0RDY - PCK3RDY: Programmable Clock Ready Status**

0 = Programmable Clock 0 to 3 is not ready.

1 = Programmable Clock 0 to 3 is ready.

23.6.16 PMC Interrupt Mask Register

Register Name: PMC_IMR

Access Type: Read-only

31	30	29	28	27	26	25	24
–	–	–	–	–	–	–	–
23	22	21	20	19	18	17	16
–	–	–	–	–	–	–	–
15	14	13	12	11	10	9	8
–	–	–	–	PCK3RDY	PCK2RDY	PCK1RDY	PCK0RDY
7	6	5	4	3	2	1	0
–	–	–	–	MCKRDY	LOCKB	LOCKA	MOSCS

- **MOSCS: Main Oscillator Status**
- **LOCKA: PLL A Lock**
- **LOCKB: PLL B Lock**
- **MCKRDY: Master Clock Ready**
- **PCK0RDY - PCK3RDY: Programmable Clock Ready**
- **MOSCS: MOSCS Interrupt Mask**

0 = The corresponding interrupt is enabled.

1 = The corresponding interrupt is disabled.

24. System Timer (ST)

24.1 Overview

The System Timer (ST) module integrates three different free-running timers:

- A Period Interval Timer (PIT) that sets the time base for an operating system.
- A Watchdog Timer (WDT) with system reset capabilities in case of software deadlock.
- A Real-Time Timer (RTT) counting elapsed seconds.

These timers count using the Slow Clock provided by the Power Management Controller. Typically, this clock has a frequency of 32.768 kHz, but the System Timer might be configured to support another frequency.

The System Timer provides an interrupt line connected to one of the sources of the Advanced Interrupt Controller (AIC). Interrupt handling requires programming the AIC before configuring the System Timer. Usually, the System Timer interrupt line is connected to the first interrupt source line and shares this entry with the Debug Unit (DBGU) and the Real Time Clock (RTC). This sharing requires the programmer to determine the source of the interrupt when the source 1 is triggered.

Important features of the System Timer include:

- One Period Interval Timer, 16-bit Programmable Counter
- One Watchdog Timer, 16-bit Programmable Counter
- One Real-time Timer, 20-bit Free-running Counter
- Interrupt Generation on Event

24.2 Block Diagram

Figure 24-1. System Timer Block Diagram

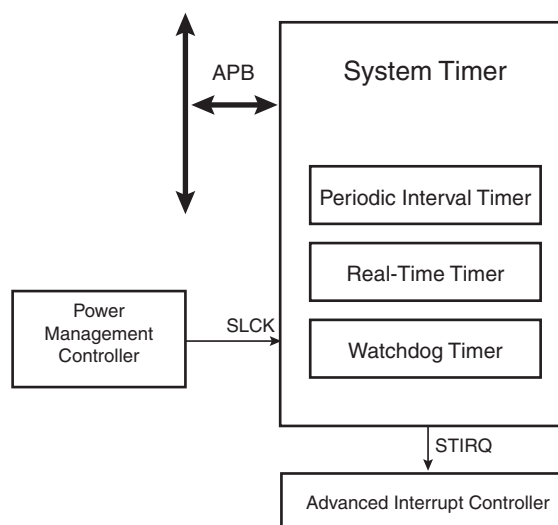

24.3 Application Block Diagram

Figure 24-2. Application Block Diagram

OS or RTOS Scheduler	Date, Time and Alarm Manager	System Survey Manager
PIT	RTT	WDT

24.4 Product Dependencies

24.4.1 Power Management

The System Timer is continuously clocked at 32768 Hz. The power management controller has no effect on the system timer behavior.

24.4.2 Interrupt Sources

The System Timer interrupt is generally connected to the source 1 of the Advanced Interrupt Controller. This interrupt line is the result of the OR-wiring of the system peripheral interrupt lines (System Timer, Real Time Clock, Power Management Controller, Memory Controller). When a system interrupt happens, the service routine must first determine the cause of the interrupt. This is accomplished by reading successively the status registers of the above mentioned system peripherals.

24.5 Functional Description

24.5.1 System Timer Clock

The System Timer uses only the SLCK clock so that it is capable to provide periodic, watchdog, second change or alarm interrupt even if the Power Management Controller is programmed to put the product in Slow Clock Mode. If the product has the capability to back up the Slow Clock oscillator and the System Timer, the System Timer can continue to operate.

24.5.2 Period Interval Timer (PIT)

The Period Interval Timer can be used to provide periodic interrupts for use by operating systems. The reset value of the PIT is 0 corresponding to the maximum value. It is built around a 16-bit down counter, which is preloaded by a value programmed in ST_PIMR (Period Interval Mode Register). When the PIT counter reaches 0, the bit PITS is set in ST_SR (Status Register), and an interrupt is generated if it is enabled.

The counter is then automatically reloaded and restarted. Writing to the ST_PIMR at any time immediately reloads and restarts the down counter with the new programmed value.

Warning: If ST_PIMR is programmed with a period less or equal to the current MCK period, the update of the PITS status bit and its associated interrupt generation are unpredictable.

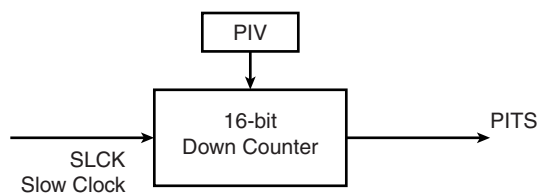
Figure 24-3. Period Interval Timer

24.5.3 Watchdog Timer (WDT)

The Watchdog Timer can be used to prevent system lock-up if the software becomes trapped in a deadlock. It is built around a 16-bit down counter loaded with the value defined in ST_WDMR (Watchdog Mode Register).

At reset, the value of the ST_WDMR is 0x00020000, corresponding to the maximum value of the counter.

It uses the Slow Clock divided by 128 to establish the maximum watchdog period to be 256 seconds (with a typical slow clock of 32.768 kHz).

In normal operation, the user reloads the Watchdog at regular intervals before the timer overflow occurs, by setting the bit WDRST in the ST_CR (Control Register).

If an overflow does occur, the watchdog timer:

- Sets the WDOVF bit in ST_SR (Status Register), from which an interrupt can be generated.
- Generates an internal reset if the parameter RSTEN in ST_WDMR is set.
- Reloads and restarts the down counter.

Writing the ST_WDMR does not reload or restart the down counter. When the ST_CR is written the watchdog counter is immediately reloaded from ST_WDMR and restarted and the Slow Clock 128 divider is also immediately reset and restarted.

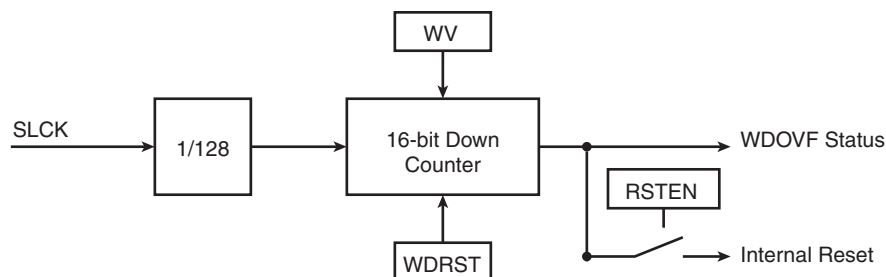
Figure 24-4. Watchdog Timer

24.5.4 Real-time Timer (RTT)

The Real-Time Timer is used to count elapsed seconds. It is built around a 20-bit counter fed by Slow Clock divided by a programmable value. At reset, this value is set to 0x8000, corresponding to feeding the real-time counter with a 1 Hz signal when the Slow Clock is 32.768 Hz. The 20-bit counter can count up to 1048576 seconds, corresponding to more than 12 days, then roll over to 0.

The Real-Time Timer value can be read at any time in the register ST_CRTR (Current Real-time Register). As this value can be updated asynchronously to the master clock, it is advisable to read this register twice at the same value to improve accuracy of the returned value.

This current value of the counter is compared with the value written in the alarm register ST_RTAR (Real-time Alarm Register). If the counter value matches the alarm, the bit ALMS in TC_SR is set. The alarm register is set to its maximum value, corresponding to 0, after a reset.

The bit RTTINC in ST_SR is set each time the 20-bit counter is incremented. This bit can be used to start an interrupt, or generate a one-second signal.

Writing the ST_RTMR immediately reloads and restarts the clock divider with the new programmed value. This also resets the 20-bit counter.

Warning: If RTPRES is programmed with a period less or equal to the current MCK period, the update of the RTTINC and ALMS status bits and their associated interrupt generation are unpredictable.

Figure 24-5. Real Time Timer

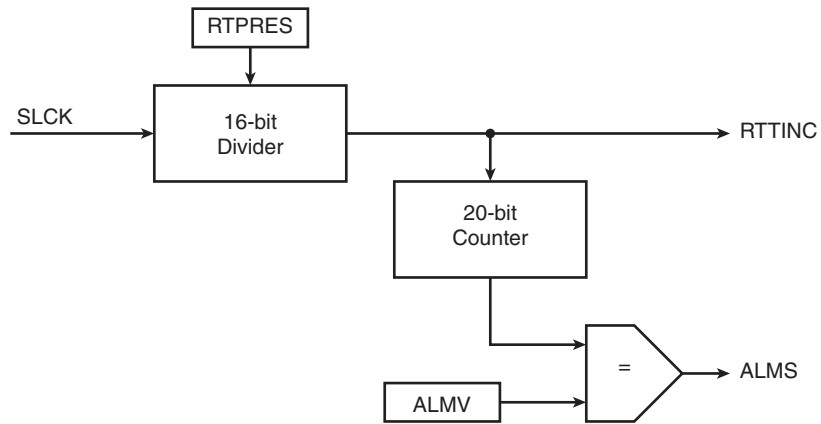

24.6 System Timer (ST) User Interface

Table 24-1. Register Mapping

Offset	Register	Name	Access	Reset Value
0x0000	Control Register	ST_CR	Write-only	–
0x0004	Period Interval Mode Register	ST_PIMR	Read/Write	0x00000000
0x0008	Watchdog Mode Register	ST_WDMR	Read/Write	0x00020000
0x000C	Real-time Mode Register	ST_RTMR	Read/Write	0x00008000
0x0010	Status Register	ST_SR	Read-only	–
0x0014	Interrupt Enable Register	ST_IER	Write-only	–
0x0018	Interrupt Disable Register	ST_IDR	Write-only	–
0x001C	Interrupt Mask Register	ST_IMR	Read-only	0x0
0x0020	Real-time Alarm Register	ST_RTAR	Read/Write	0x0
0x0024	Current Real-time Register	ST_CRTR	Read-only	0x0

24.6.1 ST Control Register

Register Name: ST_CR

Access Type: Write-only

31	30	29	28	27	26	25	24
–	–	–	–	–	–	–	–
23	22	21	20	19	18	17	16
–	–	–	–	–	–	–	–
15	14	13	12	11	10	9	8
–	–	–	–	–	–	–	–
7	6	5	4	3	2	1	0
–	–	–	–	–	–	–	WDRST

- **WDRST: Watchdog Timer Restart**

0 = No effect.

1 = Reload the start-up value in the watchdog timer.

24.6.2 ST Period Interval Mode Register

Register Name: ST_PIMR

Access Type: Read/Write

–	–	–	–	–	–	–	–
–	–	–	–	–	–	–	–
PIV							
PIV							

- **PIV: Period Interval Value**

Defines the value loaded in the 16-bit counter of the period interval timer. The maximum period is obtained by programming PIV at 0x0 corresponding to 65536 slow clock cycles.

24.6.3 ST Watchdog Mode Register

Register Name: ST_WDMR

Access Type: Read/Write

31	30	29	28	27	26	25	24
–	–	–	–	–	–	–	–
23	22	21	20	19	18	17	16
–	–	–	–	–	–	–	–
15	14	13	12	11	10	9	8
WDV							
7	6	5	4	3	2	1	0
WDV							

- **WDV: Watchdog Counter Value**

Defines the value loaded in the 16-bit counter. The maximum period is obtained by programming WDV to 0x0 corresponding to 65536 x 128 slow clock cycles.

- **RSTEN: Reset Enable**

0 = No reset is generated when a watchdog overflow occurs.

1 = An internal reset is generated when a watchdog overflow occurs.

24.6.4 ST Real-Time Mode Register

Register Name: ST_RTMR

Access Type: Read/Write

31	30	29	28	27	26	25	24
–	–	–	–	–	–	–	–
23	22	21	20	19	18	17	16
–	–	–	–	–	–	–	–
15	14	13	12	11	10	9	8
RTPRES							
7	6	5	4	3	2	1	0
RTPRES							

- **RTPRES: Real-time Timer Prescaler Value**

Defines the number of SLCK periods required to increment the real-time timer. The maximum period is obtained by programming RTPRES to 0x0 corresponding to 65536 slow clock cycles.

24.6.5 ST Status Register

Register Name: ST_SR

Access Type: Read-only

31	30	29	28	27	26	25	24
–	–	–	–	–	–	–	–
23	22	21	20	19	18	17	16
–	–	–	–	–	–	–	–
15	14	13	12	11	10	9	8
–	–	–	–	–	–	–	–
7	6	5	4	3	2	1	0
–	–	–	–	ALMS	RTTINC	WDOVF	PITS

- **PITS: Period Interval Timer Status**

0 = The period interval timer has not reached 0 since the last read of the Status Register.

1 = The period interval timer has reached 0 since the last read of the Status Register.

- **WDOVF: Watchdog Overflow**

0 = The watchdog timer has not reached 0 since the last read of the Status Register.

1 = The watchdog timer has reached 0 since the last read of the Status Register.

- **RTTINC: Real-time Timer Increment**

0 = The real-time timer has not been incremented since the last read of the Status Register.

1 = The real-time timer has been incremented since the last read of the Status Register.

- **ALMS: Alarm Status**

0 = No alarm compare has been detected since the last read of the Status Register.

1 = Alarm compare has been detected since the last read of the Status Register.

24.6.6 ST Interrupt Enable Register

Register Name: ST_IER

Access Type: Write-only

31	30	29	28	27	26	25	24
–	–	–	–	–	–	–	–
23	22	21	20	19	18	17	16
–	–	–	–	–	–	–	–
15	14	13	12	11	10	9	8
–	–	–	–	–	–	–	–
7	6	5	4	3	2	1	0
–	–	–	–	ALMS	RTTINC	WDOVF	PITS

- **PITS: Period Interval Timer Status Interrupt Enable**
- **WDOVF: Watchdog Overflow Interrupt Enable**
- **RTTINC: Real-time Timer Increment Interrupt Enable**
- **ALMS: Alarm Status Interrupt Enable**

0 = No effect.

1 = Enables the corresponding interrupt.

24.6.7 ST Interrupt Disable Register

Register Name: ST_IDR

Access Type: Write-only

31	30	29	28	27	26	25	24
–	–	–	–	–	–	–	–
23	22	21	20	19	18	17	16
–	–	–	–	–	–	–	–
15	14	13	12	11	10	9	8
–	–	–	–	–	–	–	–
7	6	5	4	3	2	1	0
–	–	–	–	ALMS	RTTINC	WDOVF	PITS

- **PITS: Period Interval Timer Status Interrupt Disable**
- **WDOVF: Watchdog Overflow Interrupt Disable**
- **RTTINC: Real-time Timer Increment Interrupt Disable**
- **ALMS: Alarm Status Interrupt Disable**

0 = No effect.

1 = Disables the corresponding interrupt.

24.6.8 ST Interrupt Mask Register

Register Name: ST_IMR

Access Type: Read-only

31	30	29	28	27	26	25	24
–	–	–	–	–	–	–	–
23	22	21	20	19	18	17	16
–	–	–	–	–	–	–	–
15	14	13	12	11	10	9	8
–	–	–	–	–	–	–	–
7	6	5	4	3	2	1	0
–	–	–	–	ALMS	RTTINC	WDOVF	PITS

- **PITS: Period Interval Timer Status Interrupt Mask**
- **WDOVF: Watchdog Overflow Interrupt Mask**
- **RTTINC: Real-time Timer Increment Interrupt Mask**
- **ALMS: Alarm Status Interrupt Mask**

0 = The corresponding interrupt is disabled.

1 = The corresponding interrupt is enabled.

24.6.9 ST Real-time Alarm Register

Register Name: ST_RTAR

Access Type: Read/Write

31	30	29	28	27	26	25	24
–	–	–	–	–	–	–	–
23	22	21	20	19	18	17	16
–	–	–	–	ALMV			
15	14	13	12	11	10	9	8
ALMV							
7	6	5	4	3	2	1	0
ALMV							

- **ALMV: Alarm Value**

Defines the alarm value compared with the real-time timer. The maximum delay before ALMS status bit activation is obtained by programming ALMV to 0x0 corresponding to 1048576 seconds.

24.6.10 ST Current Real-Time Register

Register Name: ST_CRTR

Access Type: Read-only

31	30	29	28	27	26	25	24
-	-	-	-	-	-	-	-
23	22	21	20	19	18	17	16
-	-	-	-	CRTV			
15	14	13	12	11	10	9	8
CRTV							
7	6	5	4	3	2	1	0
CRTV							

- **CRTV: Current Real-time Value**

Returns the current value of the real-time timer.

25. Real Time Clock (RTC)

25.1 Overview

The Real-time Clock (RTC) peripheral is designed for very low power consumption.

It combines a complete time-of-day clock with alarm and a two-hundred-year Gregorian calendar, complemented by a programmable periodic interrupt. The alarm and calendar registers are accessed by a 32-bit data bus.

The time and calendar values are coded in binary-coded decimal (BCD) format. The time format can be 24-hour mode or 12-hour mode with an AM/PM indicator.

Updating time and calendar fields and configuring the alarm fields are performed by a parallel capture on the 32-bit data bus. An entry control is performed to avoid loading registers with incompatible BCD format data or with an incompatible date according to the current month/year/century.

Important features of the RTC include:

- Low Power Consumption
- Full Asynchronous Design
- Two Hundred Year Calendar
- Programmable Periodic Interrupt
- Alarm and Update Parallel Load
- Control of Alarm and Update Time/Calendar Data In

25.2 Block Diagram

Figure 25-1. RTC Block Diagram

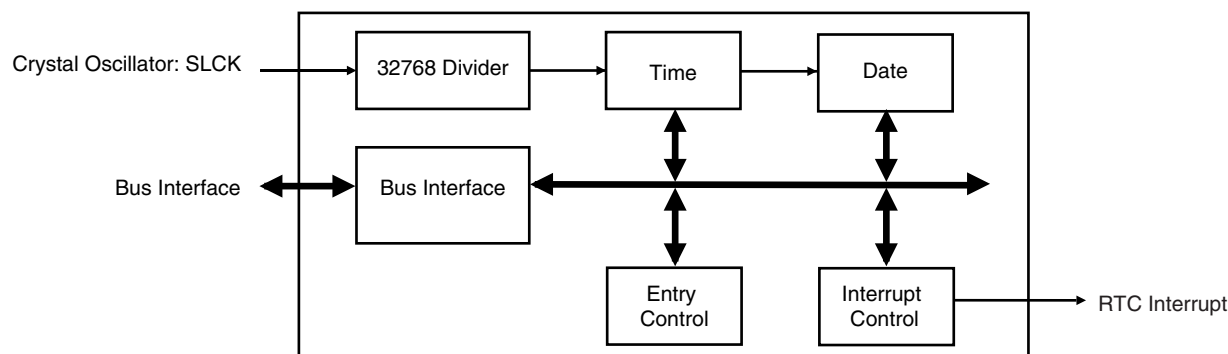

25.3 Product Dependencies

25.3.1 Power Management

The Real-time Clock is continuously clocked at 32768 Hz. The Power Management Controller has no effect on RTC behavior.

25.3.2 Interrupt

The RTC Interrupt is connected to interrupt source 1 (IRQ1) of the advanced interrupt controller. This interrupt line is due to the OR-wiring of the system peripheral interrupt lines (System Timer,

Real Time Clock, Power Management Controller, Memory Controller, etc.). When a system interrupt occurs, the service routine must first determine the cause of the interrupt. This is done by reading the status registers of the above system peripherals successively.

25.4 Functional Description

The RTC provides a full binary-coded decimal (BCD) clock that includes century (19/20), year (with leap years), month, date, day, hours, minutes and seconds.

The valid year range is 1900 to 2099, a two-hundred-year Gregorian calendar achieving full Y2K compliance.

The RTC can operate in 24-hour mode or in 12-hour mode with an AM/PM indicator.

Corrections for leap years are included (all years divisible by 4 being leap years, including year 2000). This is correct up to the year 2099.

After hardware reset, the calendar is initialized to Thursday, January 1, 1998.

25.4.1 Reference Clock

The reference clock is Slow Clock (SLCK). It can be driven by the Atmel cell OSC55 or OSC56 (or an equivalent cell) and an external 32.768 kHz crystal.

During low power modes of the processor (idle mode), the oscillator runs and power consumption is critical. The crystal selection has to take into account the current consumption for power saving and the frequency drift due to temperature effect on the circuit for time accuracy.

25.4.2 Timing

The RTC is updated in real time at one-second intervals in normal mode for the counters of seconds, at one-minute intervals for the counter of minutes and so on.

Due to the asynchronous operation of the RTC with respect to the rest of the chip, to be certain that the value read in the RTC registers (century, year, month, date, day, hours, minutes, seconds) are valid and stable, it is necessary to read these registers twice. If the data is the same both times, then it is valid. Therefore, a minimum of two and a maximum of three accesses are required.

25.4.3 Alarm

The RTC has five programmable fields: month, date, hours, minutes and seconds.

Each of these fields can be enabled or disabled to match the alarm condition:

- If all the fields are enabled, an alarm flag is generated (the corresponding flag is asserted and an interrupt generated if enabled) at a given month, date, hour/minute/second.
- If only the “seconds” field is enabled, then an alarm is generated every minute.

Depending on the combination of fields enabled, a large number of possibilities are available to the user ranging from minutes to 365/366 days.

25.4.4 Error Checking

Verification on user interface data is performed when accessing the century, year, month, date, day, hours, minutes, seconds and alarms. A check is performed on illegal BCD entries such as illegal date of the month with regard to the year and century configured.

If one of the time fields is not correct, the data is not loaded into the register/counter and a flag is set in the validity register. The user can not reset this flag. It is reset as soon as an acceptable

value is programmed. This avoids any further side effects in the hardware. The same procedure is done for the alarm.

The following checks are performed:

1. Century (check if it is in range 19 - 20)
2. Year (BCD entry check)
3. Date (check range 01 - 31)
4. Month (check if it is in BCD range 01 - 12, check validity regarding "date")
5. Day (check range 1 - 7)
6. Hour (BCD checks: in 24-hour mode, check range 00 - 23 and check that AM/PM flag is not set if RTC is set in 24-hour mode; in 12-hour mode check range 01 - 12)
7. Minute (check BCD and range 00 - 59)
8. Second (check BCD and range 00 - 59)

Note: If the 12-hour mode is selected by means of the RTC_MODE register, a 12-hour value can be programmed and the returned value on RTC_TIME will be the corresponding 24-hour value. The entry control checks the value of the AM/PM indicator (bit 22 of RTC_TIME register) to determine the range to be checked.

25.4.5 Updating Time/Calendar

To update any of the time/calendar fields, the user must first stop the RTC by setting the corresponding field in the Control Register. Bit UPDTIM must be set to update time fields (hour, minute, second) and bit UPDCAL must be set to update calendar fields (century, year, month, date, day).

Then the user must poll or wait for the interrupt (if enabled) of bit ACKUPD in the Status Register. Once the bit reads 1, the user must clear this status bit by writing ACKUPD to 1 in RTC_SCCR, and write to the appropriate register.

Once the update is finished, the user must reset (0) UPDTIM and/or UPDCAL in the Control Register.

The time and date are stopped when entering the programming mode.

It is highly recommended to prepare all the fields to update prior to entering the programming mode, to avoid a time slip in case the user would stay in the calendar update phase for several tens of seconds or more.

In successive update operations, the user must wait at least one second after resetting the UPDTIM/UPDCAL bit in the RTC_CR (Control Register) before setting these bits again. This is done by waiting for the SEC flag in the Status Register before setting UPDTIM/UPDCAL bit. After resetting UPDTIM/UPDCAL, the SEC flag must also be cleared.

25.5 Real Time Clock (RTC) User Interface

Table 25-1. RTC Register Mapping

Offset	Register	Register Name	Read/Write	Reset
0x00	RTC Control Register	RTC_CR	Read/Write	0x0
0x04	RTC Mode Register	RTC_MR	Read/Write	0x0
0x08	RTC Time Register	RTC_TIMR	Read/Write	0x0
0x0C	RTC Calendar Register	RTC_CALR	Read/Write	0x01819819
0x10	RTC Time Alarm Register	RTC_TIMALR	Read/Write	0x0
0x14	RTC Calendar Alarm Register	RTC_CALALR	Read/Write	0x01010000
0x18	RTC Status Register	RTC_SR	Read only	0x0
0x1C	RTC Status Clear Command Register	RTC_SCCR	Write only	---
0x20	RTC Interrupt Enable Register	RTC_IER	Write only	---
0x24	RTC Interrupt Disable Register	RTC_IDR	Write only	---
0x28	RTC Interrupt Mask Register	RTC_IMR	Read only	0x0
0x2C	RTC Valid Entry Register	RTC_VER	Read only	0x0

25.5.1 RTC Control Register

Name: RTC_CR

Access Type: Read/Write

31	30	29	28	27	26	25	24
–	–	–	–	–	–	–	–
23	22	21	20	19	18	17	16
–	–	–	–	–	–	CALEVSEL	
15	14	13	12	11	10	9	8
–	–	–	–	–	–	TIMEVSEL	
7	6	5	4	3	2	1	0
–	–	–	–	–	–	UPDCAL	UPDTIM

- **UPDTIM: Update Request Time Register**

0 = No effect.

1 = Stops the RTC time counting.

Time counting consists of second, minute and hour counters. Time counters can be programmed once this bit is set and acknowledged by the bit ACKUPD of the Status Register.

- **UPDCAL: Update Request Calendar Register**

0 = No effect.

1 = Stops the RTC calendar counting.

Calendar counting consists of day, date, month, year and century counters. Calendar counters can be programmed once this bit is set.

- **TIMEVSEL: Time Event Selection**

The event that generates the flag TIMEV in RTC_SR (Status Register) depends on the value of TIMEVSEL.

0 = Minute change.

1 = Hour change.

2 = Every day at midnight.

3 = Every day at noon.

- **CALEVSEL: Calendar Event Selection**

The event that generates the flag CALEV in RTC_SR depends on the value of CALEVSEL.

0 = Week change (every Monday at time 00:00:00).

1 = Month change (every 01 of each month at time 00:00:00).

2, 3 = Year change (every January 1 at time 00:00:00).

25.5.2 RTC Mode Register

Name: RTC_MR

Access Type: Read/Write

31	30	29	28	27	26	25	24
–	–	–	–	–	–	–	–
23	22	21	20	19	18	17	16
–	–	–	–	–	–	–	–
15	14	13	12	11	10	9	8
–	–	–	–	–	–	–	–
7	6	5	4	3	2	1	0
–	–	–	–	–	–	–	HRMOD

- **HRMOD: 12-/24-hour Mode**

0 = 24-hour mode is selected.

1 = 12-hour mode is selected.

All non-significant bits read zero.

25.5.3 RTC Time Register

Name: RTC_TIMR

Access Type: Read/Write

31	30	29	28	27	26	25	24
–	–	–	–	–	–	–	–
23	22	21	20	19	18	17	16
–	AMPM	HOUR					
15	14	13	12	11	10	9	8
–	MIN						
7	6	5	4	3	2	1	0
–	SEC						

- **SEC: Current Second**

The range that can be set is 0 - 59 (BCD).

The lowest four bits encode the units. The higher bits encode the tens.

- **MIN: Current Minute**

The range that can be set is 0 - 59 (BCD).

The lowest four bits encode the units. The higher bits encode the tens.

- **HOUR: Current Hour**

The range that can be set is 1 - 12 (BCD) in 12-hour mode or 0 - 23 (BCD) in 24-hour mode.

- **AMPM: Ante Meridiem Post Meridiem Indicator**

This bit is the AM/PM indicator in 12-hour mode.

0 = AM.

1 = PM.

All non-significant bits read zero.



25.5.4 RTC Calendar Register

Name: RTC_CALR

Access Type: Read/Write

31	30	29	28	27	26	25	24
–	–	DATE					
23	22	21	20	19	18	17	16
DAY			MONTH				
15	14	13	12	11	10	9	8
YEAR							
7	6	5	4	3	2	1	0
–	CENT						

• **CENT: Current Century**

The range that can be set is 19 - 20 (BCD).

The lowest four bits encode the units. The higher bits encode the tens.

• **YEAR: Current Year**

The range that can be set is 00 - 99 (BCD).

The lowest four bits encode the units. The higher bits encode the tens.

• **MONTH: Current Month**

The range that can be set is 01 - 12 (BCD).

The lowest four bits encode the units. The higher bits encode the tens.

• **DAY: Current Day**

The range that can be set is 1 - 7 (BCD).

The coding of the number (which number represents which day) is user-defined as it has no effect on the date counter.

• **DATE: Current Date**

The range that can be set is 01 - 31 (BCD).

The lowest four bits encode the units. The higher bits encode the tens.

All non-significant bits read zero.

25.5.5 RTC Time Alarm Register

Name: RTC_TIMALR

Access Type: Read/Write

31	30	29	28	27	26	25	24
–	–	–	–	–	–	–	–
23	22	21	20	19	18	17	16
HOUREN	AMPM	HOUR					
15	14	13	12	11	10	9	8
MINEN	MIN						
7	6	5	4	3	2	1	0
SECEN	SEC						

- **SEC: Second Alarm**

This field is the alarm field corresponding to the BCD-coded second counter.

- **SECEN: Second Alarm Enable**

0 = The second-matching alarm is disabled.

1 = The second-matching alarm is enabled.

- **MIN: Minute Alarm**

This field is the alarm field corresponding to the BCD-coded minute counter.

- **MINEN: Minute Alarm Enable**

0 = The minute-matching alarm is disabled.

1 = The minute-matching alarm is enabled.

- **HOUR: Hour Alarm**

This field is the alarm field corresponding to the BCD-coded hour counter.

- **AMPM: AM/PM Indicator**

This field is the alarm field corresponding to the BCD-coded hour counter.

- **HOUREN: Hour Alarm Enable**

0 = The hour-matching alarm is disabled.

1 = The hour-matching alarm is enabled.

25.5.6 RTC Calendar Alarm Register

Name: RTC_CALALR

Access Type: Read/Write

31	30	29	28	27	26	25	24
DATEEN	–	DATE					
23	22	21	20	19	18	17	16
MTHEN	–	–	MONTH				
15	14	13	12	11	10	9	8
–	–	–	–	–	–	–	–
7	6	5	4	3	2	1	0
–	–	–	–	–	–	–	–

- **MONTH: Month Alarm**

This field is the alarm field corresponding to the BCD-coded month counter.

- **MTHEN: Month Alarm Enable**

0 = The month-matching alarm is disabled.

1 = The month-matching alarm is enabled.

- **DATE: Date Alarm**

This field is the alarm field corresponding to the BCD-coded date counter.

- **DATEEN: Date Alarm Enable**

0 = The date-matching alarm is disabled.

1 = The date-matching alarm is enabled.

25.5.7 RTC Status Register

Name: RTC_SR

Access Type: Read-only

31	30	29	28	27	26	25	24
–	–	–	–	–	–	–	–
23	22	21	20	19	18	17	16
–	–	–	–	–	–	–	–
15	14	13	12	11	10	9	8
–	–	–	–	–	–	–	–
7	6	5	4	3	2	1	0
–	–	–	CALEV	TIMEV	SEC	ALARM	ACKUPD

- **ACKUPD: Acknowledge for Update**

0 = Time and calendar registers cannot be updated.

1 = Time and calendar registers can be updated.

- **ALARM: Alarm Flag**

0 = No alarm matching condition occurred.

1 = An alarm matching condition has occurred.

- **SEC: Second Event**

0 = No second event has occurred since the last clear.

1 = At least one second event has occurred since the last clear.

- **TIMEV: Time Event**

0 = No time event has occurred since the last clear.

1 = At least one time event has occurred since the last clear.

The time event is selected in the TIMEVSEL field in RTC_CTRL (Control Register) and can be any one of the following events: minute change, hour change, noon, midnight (day change).

- **CALEV: Calendar Event**

0 = No calendar event has occurred since the last clear.

1 = At least one calendar event has occurred since the last clear.

The calendar event is selected in the CALEVSEL field in RTC_CR and can be any one of the following events: week change, month change and year change.

25.5.8 RTC Status Clear Command Register

Name: RTC_SCCR

Access Type: Write-only

31	30	29	28	27	26	25	24
–	–	–	–	–	–	–	–
23	22	21	20	19	18	17	16
–	–	–	–	–	–	–	–
15	14	13	12	11	10	9	8
–	–	–	–	–	–	–	–
7	6	5	4	3	2	1	0
–	–	–	CALCLR	TIMCLR	SECCLR	ALRCLR	ACKCLR

- **Status Flag Clear**

0 = No effect.

1 = Clears corresponding status flag in the Status Register (RTC_SR).

25.5.9 RTC Interrupt Enable Register

Name: RTC_IER

Access Type: Write-only

31	30	29	28	27	26	25	24
–	–	–	–	–	–	–	–
23	22	21	20	19	18	17	16
–	–	–	–	–	–	–	–
15	14	13	12	11	10	9	8
–	–	–	–	–	–	–	–
7	6	5	4	3	2	1	0
–	–	–	CALEN	TIMEN	SECEN	ALREN	ACKEN

- **ACKEN: Acknowledge Update Interrupt Enable**

0 = No effect.

1 = The acknowledge for update interrupt is enabled.

- **ALREN: Alarm Interrupt Enable**

0 = No effect.

1 = The alarm interrupt is enabled.

- **SECEN: Second Event Interrupt Enable**

0 = No effect.

1 = The second periodic interrupt is enabled.

- **TIMEN: Time Event Interrupt Enable**

0 = No effect.

1 = The selected time event interrupt is enabled.

- **CALEN: Calendar Event Interrupt Enable**

0 = No effect.

1 = The selected calendar event interrupt is enabled.

25.5.10 RTC Interrupt Disable Register

Name: RTC_IDR

Access Type: Write-only

31	30	29	28	27	26	25	24
–	–	–	–	–	–	–	–
23	22	21	20	19	18	17	16
–	–	–	–	–	–	–	–
15	14	13	12	11	10	9	8
–	–	–	–	–	–	–	–
7	6	5	4	3	2	1	0
–	–	–	CALDIS	TIMDIS	SECDIS	ALRDIS	ACKDIS

- **ACKDIS: Acknowledge Update Interrupt Disable**

0 = No effect.

1 = The acknowledge for update interrupt is disabled.

- **ALRDIS: Alarm Interrupt Disable**

0 = No effect.

1 = The alarm interrupt is disabled.

- **SECDIS: Second Event Interrupt Disable**

0 = No effect.

1 = The second periodic interrupt is disabled.

- **TIMDIS: Time Event Interrupt Disable**

0 = No effect.

1 = The selected time event interrupt is disabled.

- **CALDIS: Calendar Event Interrupt Disable**

0 = No effect.

1 = The selected calendar event interrupt is disabled.

25.5.11 RTC Interrupt Mask Register

Name: RTC_IMR

Access Type: Read-only

31	30	29	28	27	26	25	24
–	–	–	–	–	–	–	–
23	22	21	20	19	18	17	16
–	–	–	–	–	–	–	–
15	14	13	12	11	10	9	8
–	–	–	–	–	–	–	–
7	6	5	4	3	2	1	0
–	–	–	CAL	TIM	SEC	ALR	ACK

- **ACK: Acknowledge Update Interrupt Mask**

0 = The acknowledge for update interrupt is disabled.

1 = The acknowledge for update interrupt is enabled.

- **ALR: Alarm Interrupt Mask**

0 = The alarm interrupt is disabled.

1 = The alarm interrupt is enabled.

- **SEC: Second Event Interrupt Mask**

0 = The second periodic interrupt is disabled.

1 = The second periodic interrupt is enabled.

- **TIM: Time Event Interrupt Mask**

0 = The selected time event interrupt is disabled.

1 = The selected time event interrupt is enabled.

- **CAL: Calendar Event Interrupt Mask**

0 = The selected calendar event interrupt is disabled.

1 = The selected calendar event interrupt is enabled.

25.5.12 RTC Valid Entry Register

Name: RTC_VER

Access Type: Read-only

31	30	29	28	27	26	25	24
–	–	–	–	–	–	–	–
23	22	21	20	19	18	17	16
–	–	–	–	–	–	–	–
15	14	13	12	11	10	9	8
–	–	–	–	–	–	–	–
7	6	5	4	3	2	1	0
–	–	–	–	NVCALAR	NVTIMALR	NVCAL	NVTIM

- **NVTIM: Non valid Time**

0 = No invalid data has been detected in RTC_TIMR (Time Register).

1 = RTC_TIMR has contained invalid data since it was last programmed.

- **NVCAL: Non valid Calendar**

0 = No invalid data has been detected in RTC_CALR (Calendar Register).

1 = RTC_CALR has contained invalid data since it was last programmed.

- **NVTIMALR: Non valid Time Alarm**

0 = No invalid data has been detected in RTC_TIMALR (Time Alarm Register).

1 = RTC_TIMALR has contained invalid data since it was last programmed.

- **NVCALALR: Non valid Calendar Alarm**

0 = No invalid data has been detected in RTC_CALALR (Calendar Alarm Register).

1 = RTC_CALALR has contained invalid data since it was last programmed.

26. Debug Unit (DBGU)

26.1 Overview

The Debug Unit provides a single entry point from the processor for access to all the debug capabilities of Atmel's ARM-based systems.

The Debug Unit features a two-pin UART that can be used for several debug and trace purposes and offers an ideal medium for in-situ programming solutions and debug monitor communications. Moreover, the association with two Peripheral DMA Controller channels permits packet handling for these tasks with processor time reduced to a minimum.

The Debug Unit also makes the Debug Communication Channel (DCC) signals provided by the In-circuit Emulator of the ARM processor visible to the software. These signals indicate the status of the DCC read and write registers and generate an interrupt to the ARM processor, making possible the handling of the DCC under interrupt control.

Chip Identifier registers permit recognition of the device and its revision. These registers inform as to the sizes and types of the on-chip memories, as well as the set of embedded peripherals.

Finally, the Debug Unit features a Force NTRST capability that enables the software to decide whether to prevent access to the system via the In-circuit Emulator. This permits protection of the code, stored in ROM.

Important features of the Debug Unit are:

- System Peripheral to Facilitate Debug of Atmel's ARM-based Systems
- Composed of Three Functions
 - Two-pin UART
 - Debug Communication Channel (DCC) Support
 - Chip ID Registers
- Two-pin UART
 - Implemented Features are 100% Compatible with the Standard Atmel USART
 - Independent Receiver and Transmitter with a Common Programmable Baud Rate Generator
 - Even, Odd, Mark or Space Parity Generation
 - Parity, Framing and Overrun Error Detection
 - Automatic Echo, Local Loopback and Remote Loopback Channel Modes
 - Interrupt Generation
 - Support for Two Peripheral DMA Controller (PDC) Channels with Connection to Receiver and Transmitter
- Debug Communication Channel Support
 - Offers Visibility of COMMRX and COMMTX Signals from the ARM Processor
 - Interrupt Generation
- Chip ID Registers
 - Identification of the Device Revision, Sizes of the Embedded Memories, Set of Peripherals

26.2 Block Diagram

Figure 26-1. Debug Unit Functional Block Diagram

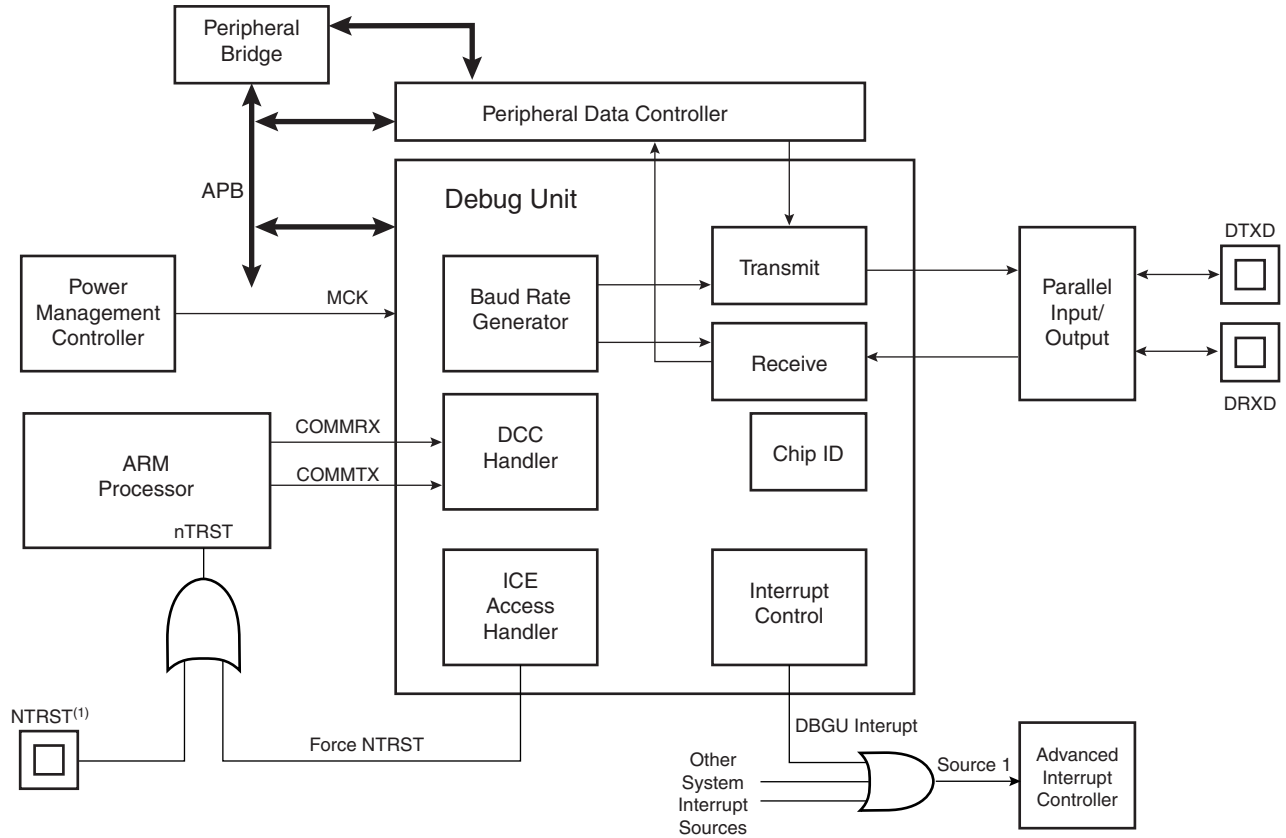

Note: 1. If NTRST pad is not bonded out, it is connected to NRST.

Table 26-1. Debug Unit Pin Description

Pin Name	Description	Type
DRXD	Debug Receive Data	Input
DTXD	Debug Transmit Data	Output

Figure 26-2. Debug Unit Application Example

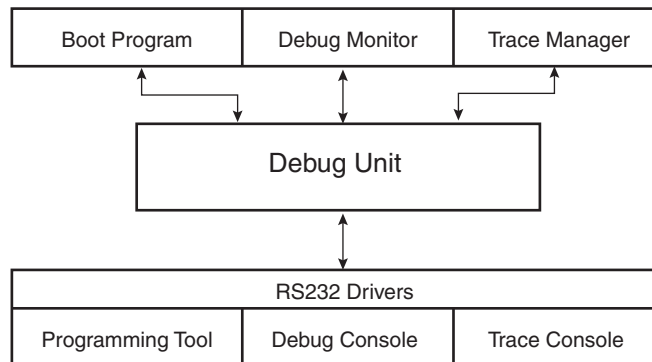

26.3 Product Dependencies

26.3.1 I/O Lines

Depending on product integration, the Debug Unit pins may be multiplexed with PIO lines. In this case, the programmer must first configure the corresponding PIO Controller to enable I/O lines operations of the Debug Unit.

26.3.2 Power Management

Depending on product integration, the Debug Unit clock may be controllable through the Power Management Controller. In this case, the programmer must first configure the PMC to enable the Debug Unit clock. Usually, the peripheral identifier used for this purpose is 1.

26.3.3 Interrupt Source

Depending on product integration, the Debug Unit interrupt line is connected to one of the interrupt sources of the Advanced Interrupt Controller. Interrupt handling requires programming of the AIC before configuring the Debug Unit. Usually, the Debug Unit interrupt line connects to the interrupt source 1 of the AIC, which may be shared with the real-time clock, the system timer interrupt lines and other system peripheral interrupts, as shown in [Figure 26-1](#). This sharing requires the programmer to determine the source of the interrupt when the source 1 is triggered.

26.4 UART Operations

The Debug Unit operates as a UART, (asynchronous mode only) and supports only 8-bit character handling (with parity). It has no clock pin.

The Debug Unit's UART is made up of a receiver and a transmitter that operate independently, and a common baud rate generator. Receiver timeout and transmitter time guard are not implemented. However, all the implemented features are compatible with those of a standard USART.

26.4.1 Baud Rate Generator

The baud rate generator provides the bit period clock named baud rate clock to both the receiver and the transmitter.

The baud rate clock is the master clock divided by 16 times the value (CD) written in DBGU_BRGR (Baud Rate Generator Register). If DBGU_BRGR is set to 0, the baud rate clock is disabled and the Debug Unit's UART remains inactive. The maximum allowable baud rate is Master Clock divided by 16. The minimum allowable baud rate is Master Clock divided by (16 x 65536).

$$\text{Baud Rate} = \frac{\text{MCK}}{16 \times \text{CD}}$$

Figure 26-3. Baud Rate Generator

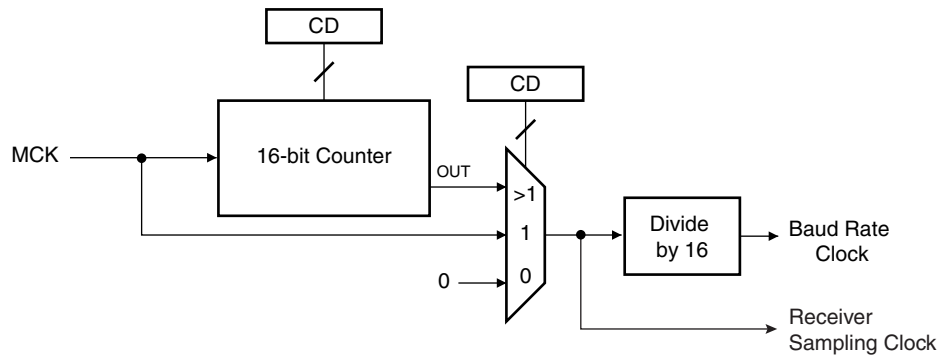

26.4.2 Receiver

26.4.2.1 Receiver Reset, Enable and Disable

After device reset, the Debug Unit receiver is disabled and must be enabled before being used. The receiver can be enabled by writing the control register `DBGU_CR` with the bit `RXEN` at 1. At this command, the receiver starts looking for a start bit.

The programmer can disable the receiver by writing `DBGU_CR` with the bit `RXDIS` at 1. If the receiver is waiting for a start bit, it is immediately stopped. However, if the receiver has already detected a start bit and is receiving the data, it waits for the stop bit before actually stopping its operation.

The programmer can also put the receiver in its reset state by writing `DBGU_CR` with the bit `RSTRX` at 1. In doing so, the receiver immediately stops its current operations and is disabled, whatever its current state. If `RSTRX` is applied when data is being processed, this data is lost.

26.4.2.2 Start Detection and Data Sampling

The Debug Unit only supports asynchronous operations, and this affects only its receiver. The Debug Unit receiver detects the start of a received character by sampling the `DRXD` signal until it detects a valid start bit. A low level (space) on `DRXD` is interpreted as a valid start bit if it is detected for more than 7 cycles of the sampling clock, which is 16 times the baud rate. Hence, a space that is longer than $7/16$ of the bit period is detected as a valid start bit. A space which is $7/16$ of a bit period or shorter is ignored and the receiver continues to wait for a valid start bit.

When a valid start bit has been detected, the receiver samples the `DRXD` at the theoretical midpoint of each bit. It is assumed that each bit lasts 16 cycles of the sampling clock (1-bit period) so the bit sampling point is eight cycles (0.5-bit period) after the start of the bit. The first sampling point is therefore 24 cycles (1.5-bit periods) after the falling edge of the start bit was detected.

Each subsequent bit is sampled 16 cycles (1-bit period) after the previous one.

Figure 26-4. Start Bit Detection

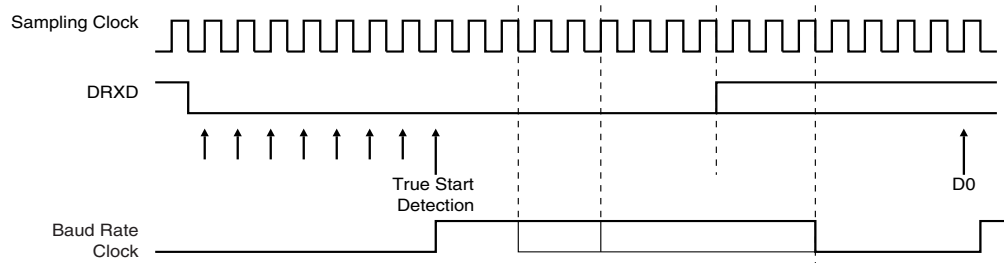
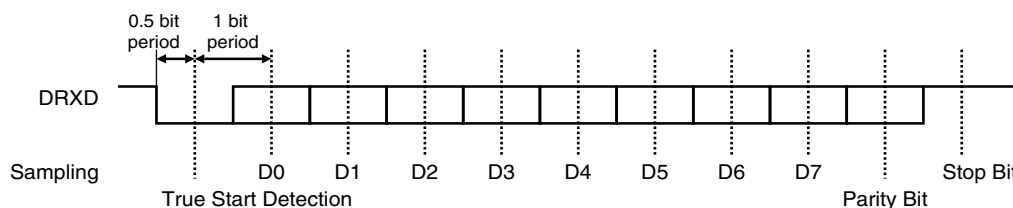

Figure 26-5. Character Reception

Example: 8-bit, parity enabled 1 stop



26.4.2.3 Receiver Ready

When a complete character is received, it is transferred to the DBGU_RHR and the RXRDY status bit in DBGU_SR (Status Register) is set. The bit RXRDY is automatically cleared when the receive holding register DBGU_RHR is read.

Figure 26-6. Receiver Ready

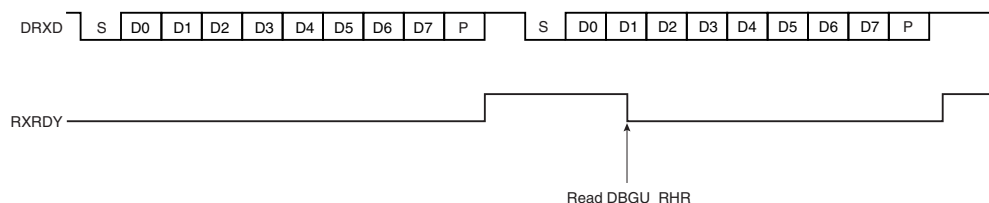

26.4.2.4 Receiver Overrun

If DBGU_RHR has not been read by the software (or the Peripheral DMA Controller) since the last transfer, the RXRDY bit is still set and a new character is received, the OVRE status bit in DBGU_SR is set. OVRE is cleared when the software writes the control register DBGU_CR with the bit RSTSTA (Reset Status) at 1.

Figure 26-7. Receiver Overrun

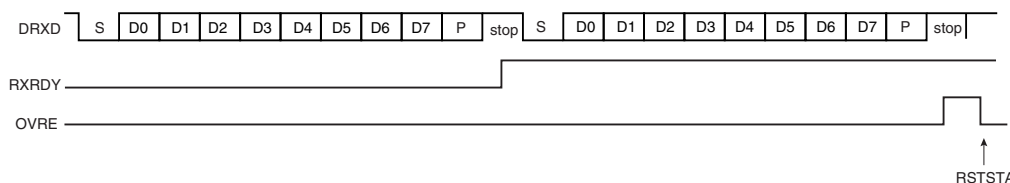

26.4.2.5 Parity Error

Each time a character is received, the receiver calculates the parity of the received data bits, in accordance with the field PAR in DBGU_MR. It then compares the result with the received parity

bit. If different, the parity error bit PARE in DBGU_SR is set at the same time the RXRDY is set. The parity bit is cleared when the control register DBGU_CR is written with the bit RSTSTA (Reset Status) at 1. If a new character is received before the reset status command is written, the PARE bit remains at 1.

Figure 26-8. Parity Error

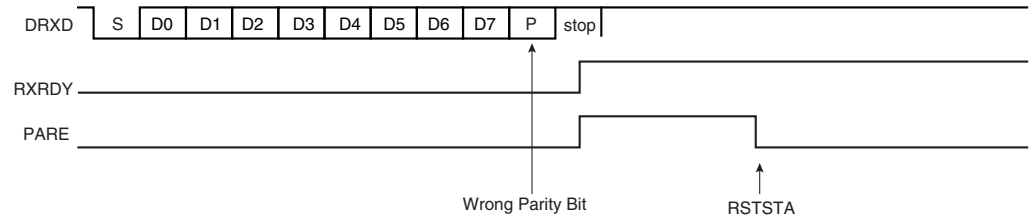

26.4.2.6 Receiver Framing Error

When a start bit is detected, it generates a character reception when all the data bits have been sampled. The stop bit is also sampled and when it is detected at 0, the FRAME (Framing Error) bit in DBGU_SR is set at the same time the RXRDY bit is set. The bit FRAME remains high until the control register DBGU_CR is written with the bit RSTSTA at 1.

Figure 26-9. Receiver Framing Error

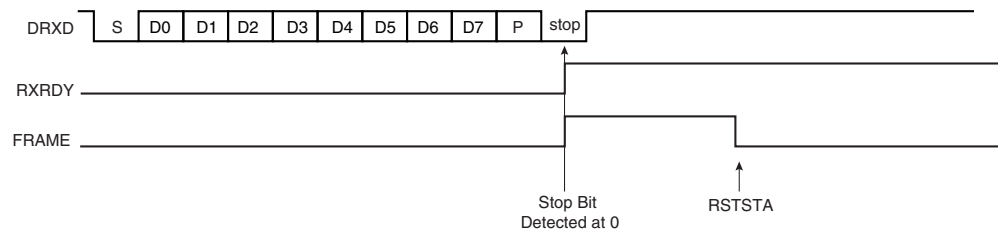

26.4.3 Transmitter

26.4.3.1 Transmitter Reset, Enable and Disable

After device reset, the Debug Unit transmitter is disabled and it must be enabled before being used. The transmitter is enabled by writing the control register DBGU_CR with the bit TXEN at 1. From this command, the transmitter waits for a character to be written in the Transmit Holding Register DBGU_THR before actually starting the transmission.

The programmer can disable the transmitter by writing DBGU_CR with the bit TXDIS at 1. If the transmitter is not operating, it is immediately stopped. However, if a character is being processed into the Shift Register and/or a character has been written in the Transmit Holding Register, the characters are completed before the transmitter is actually stopped.

The programmer can also put the transmitter in its reset state by writing the DBGU_CR with the bit RSTTX at 1. This immediately stops the transmitter, whether or not it is processing characters.

26.4.3.2 Transmit Format

The Debug Unit transmitter drives the pin DTXD at the baud rate clock speed. The line is driven depending on the format defined in the Mode Register and the data stored in the Shift Register. One start bit at level 0, then the 8 data bits, from the lowest to the highest bit, one optional parity bit and one stop bit at 1 are consecutively shifted out as shown on the following figure. The field

PARE in the mode register DBGU_MR defines whether or not a parity bit is shifted out. When a parity bit is enabled, it can be selected between an odd parity, an even parity, or a fixed space or mark bit.

Figure 26-10. Character Transmission

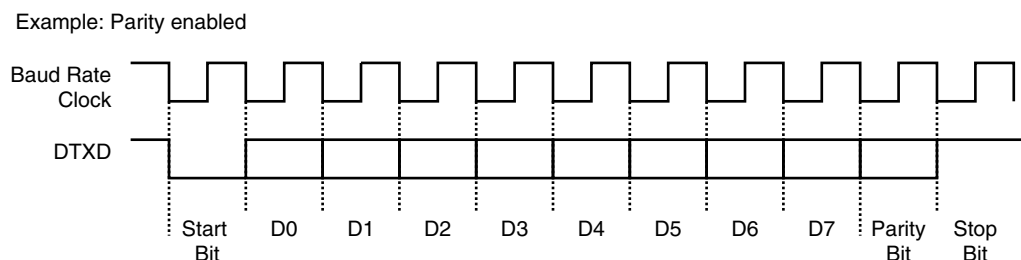

26.4.3.3 Transmitter Control

When the transmitter is enabled, the bit TXRDY (Transmitter Ready) is set in the status register DBGU_SR. The transmission starts when the programmer writes in the Transmit Holding Register DBGU_THR, and after the written character is transferred from DBGU_THR to the Shift Register. The bit TXRDY remains high until a second character is written in DBGU_THR. As soon as the first character is completed, the last character written in DBGU_THR is transferred into the shift register and TXRDY rises again, showing that the holding register is empty.

When both the Shift Register and the DBGU_THR are empty, i.e., all the characters written in DBGU_THR have been processed, the bit TXEMPTY rises after the last stop bit has been completed.

Figure 26-11. Transmitter Control

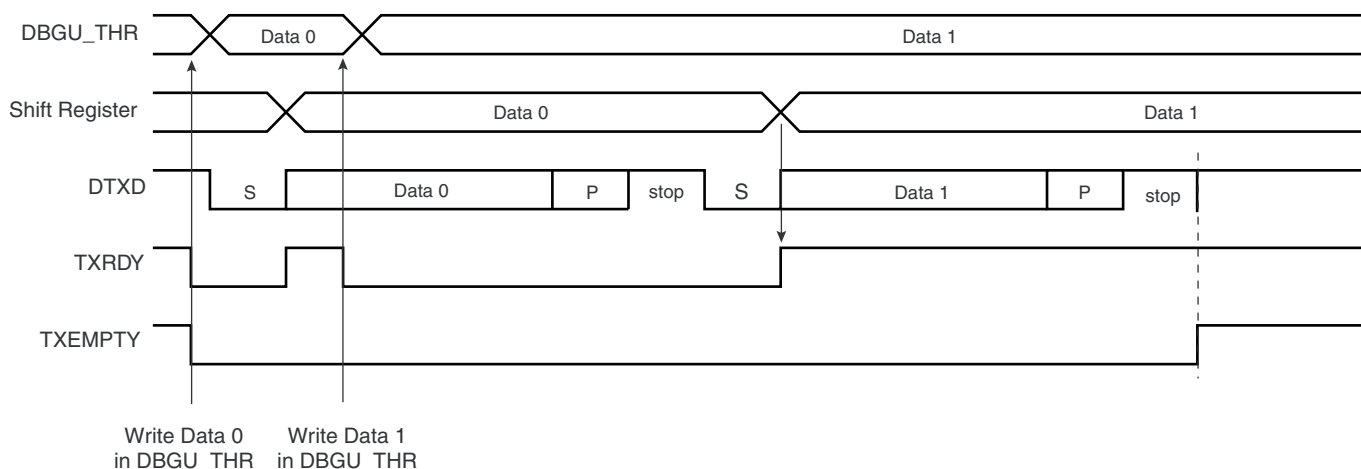

26.4.4 Peripheral DMA Controller

Both the receiver and the transmitter of the Debug Unit's UART are generally connected to a Peripheral DMA Controller (PDC) channel.

The Peripheral DMA controller channels are programmed via registers that are mapped within the Debug Unit user interface from the offset 0x100. The status bits are reported in the Debug Unit status register DBGU_SR and can generate an interrupt.

The RXRDY bit triggers the PDC channel data transfer of the receiver. This results in a read of the data in DBGU_RHR. The TXRDY bit triggers the PDC channel data transfer of the transmitter. This results in a write of a data in DBGU_THR.

26.4.5 Test Modes

The Debug Unit supports three tests modes. These modes of operation are programmed by using the field CHMODE (Channel Mode) in the mode register DBGU_MR.

The Automatic Echo mode allows bit-by-bit retransmission. When a bit is received on the DRXD line, it is sent to the DTXD line. The transmitter operates normally, but has no effect on the DTXD line.

The Local Loopback mode allows the transmitted characters to be received. DTXD and DRXD pins are not used and the output of the transmitter is internally connected to the input of the receiver. The DRXD pin level has no effect and the DTXD line is held high, as in idle state.

The Remote Loopback mode directly connects the DRXD pin to the DTXD line. The transmitter and the receiver are disabled and have no effect. This mode allows a bit-by-bit retransmission.

Figure 26-12. Test Modes

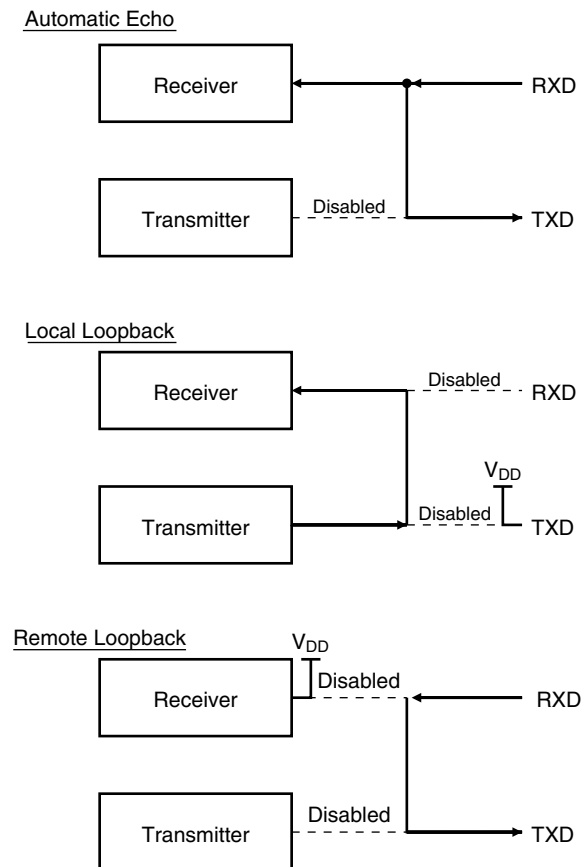

26.4.6 Debug Communication Channel Support

The Debug Unit handles the signals COMMRX and COMMTX that come from the Debug Communication Channel of the ARM Processor and are driven by the In-circuit Emulator.

The Debug Communication Channel contains two registers that are accessible through the ICE Breaker on the JTAG side and through the coprocessor 0 on the ARM Processor side.

As a reminder, the following instructions are used to read and write the Debug Communication Channel:

```
MRC    p14, 0, Rd, c1, c0, 0
```

Returns the debug communication data read register into Rd

```
MCR    p14, 0, Rd, c1, c0, 0
```

Writes the value in Rd to the debug communication data write register.

The bits COMMRX and COMMTX, which indicate, respectively, that the read register has been written by the debugger but not yet read by the processor, and that the write register has been written by the processor and not yet read by the debugger, are wired on the two highest bits of the status register DBGU_SR. These bits can generate an interrupt. This feature permits handling under interrupt a debug link between a debug monitor running on the target system and a debugger.

26.4.7 Chip Identifier

The Debug Unit features two chip identifier registers, DBGU_CIDR (Chip ID Register) and DBGU_EXID (Extension ID). Both registers contain a hard-wired value that is read-only. The first register contains the following fields:

- EXT - shows the use of the extension identifier register
- NVPTYP and NVPSIZ - identifies the type of embedded non-volatile memory and its size
- ARCH - identifies the set of embedded peripheral
- SRAMSIZ - indicates the size of the embedded SRAM
- EPROC - indicates the embedded ARM processor
- VERSION - gives the revision of the silicon

The second register is device-dependent and reads 0 if the bit EXT is 0.

26.5 Debug Unit User Interface

Table 26-2. Debug Unit Memory Map

Offset	Register	Name	Access	Reset Value
0x0000	Control Register	DBGU_CR	Write-only	–
0x0004	Mode Register	DBGU_MR	Read/Write	0x0
0x0008	Interrupt Enable Register	DBGU_IER	Write-only	–
0x000C	Interrupt Disable Register	DBGU_IDR	Write-only	–
0x0010	Interrupt Mask Register	DBGU_IMR	Read-only	0x0
0x0014	Status Register	DBGU_SR	Read-only	–
0x0018	Receive Holding Register	DBGU_RHR	Read-only	0x0
0x001C	Transmit Holding Register	DBGU_THR	Write-only	–
0x0020	Baud Rate Generator Register	DBGU_BRGR	Read/Write	0x0
0x0024 - 0x003C	Reserved	–	–	–
0x0040	Chip ID Register	DBGU_CIDR	Read-only	–
0x0044	Chip ID Extension Register	DBGU_EXID	Read-only	–
	Reserved			
0x004C - 0x00FC	Reserved	–	–	–
0x0100 - 0x0124	PDC Area	–	–	–

26.5.1 Debug Unit Control Register

Name: DBGU_CR

Access Type: Write-only

31	30	29	28	27	26	25	24
–	–	–	–	–	–	–	–
23	22	21	20	19	18	17	16
–	–	–	–	–	–	–	–
15	14	13	12	11	10	9	8
–	–	–	–	–	–	–	RSTSTA
7	6	5	4	3	2	1	0
TXDIS	TXEN	RXDIS	RXEN	RSTTX	RSTRX	–	–

- **RSTRX: Reset Receiver**

0 = No effect.

1 = The receiver logic is reset and disabled. If a character is being received, the reception is aborted.

- **RSTTX: Reset Transmitter**

0 = No effect.

1 = The transmitter logic is reset and disabled. If a character is being transmitted, the transmission is aborted.

- **RXEN: Receiver Enable**

0 = No effect.

1 = The receiver is enabled if RXDIS is 0.

- **RXDIS: Receiver Disable**

0 = No effect.

1 = The receiver is disabled. If a character is being processed and RSTRX is not set, the character is completed before the receiver is stopped.

- **TXEN: Transmitter Enable**

0 = No effect.

1 = The transmitter is enabled if TXDIS is 0.

- **TXDIS: Transmitter Disable**

0 = No effect.

1 = The transmitter is disabled. If a character is being processed and a character has been written the DBGU_THR and RSTTX is not set, both characters are completed before the transmitter is stopped.

- **RSTSTA: Reset Status Bits**

0 = No effect.

1 = Resets the status bits PARE, FRAME and OVRE in the DBGU_SR.

26.5.2 Debug Unit Mode Register

Name: DBGU_MR

Access Type: Read/Write

31	30	29	28	27	26	25	24
–	–	–	–	–	–	–	–
23	22	21	20	19	18	17	16
–	–	–	–	–	–	–	–
15	14	13	12	11	10	9	8
CHMODE		–	–	PAR		–	
7	6	5	4	3	2	1	0
–	–	–	–	–	–	–	–

- **PAR: Parity Type**

PAR			Parity Type
0	0	0	Even parity
0	0	1	Odd parity
0	1	0	Space: parity forced to 0
0	1	1	Mark: parity forced to 1
1	x	x	No parity

- **CHMODE: Channel Mode**

CHMODE		Mode Description
0	0	Normal Mode
0	1	Automatic Echo
1	0	Local Loopback
1	1	Remote Loopback

26.5.3 Debug Unit Interrupt Enable Register

Name: DBGU_IER

Access Type: Write-only

31	30	29	28	27	26	25	24
COMMRX	COMMTX	–	–	–	–	–	–
23	22	21	20	19	18	17	16
–	–	–	–	–	–	–	–
15	14	13	12	11	10	9	8
–	–	–	RXBUFF	TXBUFE	–	TXEMPTY	–
7	6	5	4	3	2	1	0
PARE	FRAME	OVRE	ENDTX	ENDRX	–	TXRDY	RXRDY

- **RXRDY:** Enable RXRDY Interrupt
- **TXRDY:** Enable TXRDY Interrupt
- **ENDRX:** Enable End of Receive Transfer Interrupt
- **ENDTX:** Enable End of Transmit Interrupt
- **OVRE:** Enable Overrun Error Interrupt
- **FRAME:** Enable Framing Error Interrupt
- **PARE:** Enable Parity Error Interrupt
- **TXEMPTY:** Enable TXEMPTY Interrupt
- **TXBUFE:** Enable Buffer Empty Interrupt
- **RXBUFF:** Enable Buffer Full Interrupt
- **COMMTX:** Enable COMMTX (from ARM) Interrupt
- **COMMRX:** Enable COMMRX (from ARM) Interrupt

0 = No effect.

1 = Enables the corresponding interrupt.

26.5.4 Debug Unit Interrupt Disable Register

Name: DBGU_IDR

Access Type: Write-only

31	30	29	28	27	26	25	24
COMMRX	COMMTX	–	–	–	–	–	–
23	22	21	20	19	18	17	16
–	–	–	–	–	–	–	–
15	14	13	12	11	10	9	8
–	–	–	RXBUFF	TXBUFE	–	TXEMPTY	–
7	6	5	4	3	2	1	0
PARE	FRAME	OVRE	ENDTX	ENDRX	–	TXRDY	RXRDY

- **RXRDY: Disable RXRDY Interrupt**
- **TXRDY: Disable TXRDY Interrupt**
- **ENDRX: Disable End of Receive Transfer Interrupt**
- **ENDTX: Disable End of Transmit Interrupt**
- **OVRE: Disable Overrun Error Interrupt**
- **FRAME: Disable Framing Error Interrupt**
- **PARE: Disable Parity Error Interrupt**
- **TXEMPTY: Disable TXEMPTY Interrupt**
- **TXBUFE: Disable Buffer Empty Interrupt**
- **RXBUFF: Disable Buffer Full Interrupt**
- **COMMTX: Disable COMMTX (from ARM) Interrupt**
- **COMMRX: Disable COMMRX (from ARM) Interrupt**

0 = No effect.

1 = Disables the corresponding interrupt.

26.5.5 Debug Unit Interrupt Mask Register

Name: DBGU_IMR

Access Type: Read-only

31	30	29	28	27	26	25	24
COMMRX	COMMTX	–	–	–	–	–	–
23	22	21	20	19	18	17	16
–	–	–	–	–	–	–	–
15	14	13	12	11	10	9	8
–	–	–	RXBUFF	TXBUFE	–	TXEMPTY	–
7	6	5	4	3	2	1	0
PARE	FRAME	OVRE	ENDTX	ENDRX	–	TXRDY	RXRDY

- **RXRDY: Mask RXRDY Interrupt**
- **TXRDY: Disable TXRDY Interrupt**
- **ENDRX: Mask End of Receive Transfer Interrupt**
- **ENDTX: Mask End of Transmit Interrupt**
- **OVRE: Mask Overrun Error Interrupt**
- **FRAME: Mask Framing Error Interrupt**
- **PARE: Mask Parity Error Interrupt**
- **TXEMPTY: Mask TXEMPTY Interrupt**
- **TXBUFE: Mask TXBUFE Interrupt**
- **RXBUFF: Mask RXBUFF Interrupt**
- **COMMTX: Mask COMMTX Interrupt**
- **COMMRX: Mask COMMRX Interrupt**

0 = The corresponding interrupt is disabled.

1 = The corresponding interrupt is enabled.

26.5.6 Debug Unit Status Register

Name: DBGU_SR

Access Type: Read-only

31	30	29	28	27	26	25	24
COMMRX	COMMTX	–	–	–	–	–	–
23	22	21	20	19	18	17	16
–	–	–	–	–	–	–	–
15	14	13	12	11	10	9	8
–	–	–	RXBUFF	TXBUFE	–	TXEMPTY	–
7	6	5	4	3	2	1	0
PARE	FRAME	OVRE	ENDTX	ENDRX	–	TXRDY	RXRDY

- **RXRDY: Receiver Ready**

0 = No character has been received since the last read of the DBGU_RHR or the receiver is disabled.

1 = At least one complete character has been received, transferred to DBGU_RHR and not yet read.

- **TXRDY: Transmitter Ready**

0 = A character has been written to DBGU_THR and not yet transferred to the Shift Register, or the transmitter is disabled.

1 = There is no character written to DBGU_THR not yet transferred to the Shift Register.

- **ENDRX: End of Receiver Transfer**

0 = The End of Transfer signal from the receiver Peripheral DMA Controller channel is inactive.

1 = The End of Transfer signal from the receiver Peripheral DMA Controller channel is active.

- **ENDTX: End of Transmitter Transfer**

0 = The End of Transfer signal from the transmitter Peripheral DMA Controller channel is inactive.

1 = The End of Transfer signal from the transmitter Peripheral DMA Controller channel is active.

- **OVRE: Overrun Error**

0 = No overrun error has occurred since the last RSTSTA.

1 = At least one overrun error has occurred since the last RSTSTA.

- **FRAME: Framing Error**

0 = No framing error has occurred since the last RSTSTA.

1 = At least one framing error has occurred since the last RSTSTA.

- **PARE: Parity Error**

0 = No parity error has occurred since the last RSTSTA.

1 = At least one parity error has occurred since the last RSTSTA.

- **TXEMPTY: Transmitter Empty**

0 = There are characters in DBGU_THR, or characters being processed by the transmitter, or the transmitter is disabled.

1 = There are no characters in DBGU_THR and there are no characters being processed by the transmitter.

- **TXBUFE: Transmission Buffer Empty**

0 = The buffer empty signal from the transmitter PDC channel is inactive.

1 = The buffer empty signal from the transmitter PDC channel is active.

- **RXBUFF: Receive Buffer Full**

0 = The buffer full signal from the receiver PDC channel is inactive.

1 = The buffer full signal from the receiver PDC channel is active.

- **COMMTX: Debug Communication Channel Write Status**

0 = COMMTX from the ARM processor is inactive.

1 = COMMTX from the ARM processor is active.

- **COMMRX: Debug Communication Channel Read Status**

0 = COMMRX from the ARM processor is inactive.

1 = COMMRX from the ARM processor is active.



26.5.7 Debug Unit Receiver Holding Register

Name: DBGU_RHR

Access Type: Read-only

31	30	29	28	27	26	25	24
-	-	-	-	-	-	-	-
23	22	21	20	19	18	17	16
-	-	-	-	-	-	-	-
15	14	13	12	11	10	9	8
-	-	-	-	-	-	-	-
7	6	5	4	3	2	1	0
RXCHR							

- **RXCHR: Received Character**

Last received character if RXRDY is set.



Debug Unit Transmit Holding Register

Name: DBGU_THR

Access Type: Write-only

31	30	29	28	27	26	25	24
–	–	–	–	–	–	–	–
23	22	21	20	19	18	17	16
–	–	–	–	–	–	–	–
15	14	13	12	11	10	9	8
–	–	–	–	–	–	–	–
7	6	5	4	3	2	1	0
TXCHR							

• **TXCHR: Character to be Transmitted**

Next character to be transmitted after the current character if TXRDY is not set.

26.5.8 Debug Unit Baud Rate Generator Register

Name: DBGU_BRGR

Access Type: Read/Write

31	30	29	28	27	26	25	24
–	–	–	–	–	–	–	–
23	22	21	20	19	18	17	16
–	–	–	–	–	–	–	–
15	14	13	12	11	10	9	8
CD							
7	6	5	4	3	2	1	0
CD							

• **CD: Clock Divisor**

CD	Baud Rate Clock
0	Disabled
1	MCK
2 to 65535	$MCK / (CD \times 16)$

26.5.9 Debug Unit Chip ID Register

Name: DBGU_CIDR

Access Type: Read-only

31	30	29	28	27	26	25	24
EXT	NVPTYP			ARCH			
23	22	21	20	19	18	17	16
ARCH				SRAMSIZ			
15	14	13	12	11	10	9	8
0	0	0	0	NVPSIZ			
7	6	5	4	3	2	1	0
EPROC				VERSION			

- **VERSION:** Version of the device
- **EPROC:** Embedded Processor

EPROC			Processor
0	0	1	ARM946ES™
0	1	0	ARM7TDMI®
1	0	0	ARM920T

- **NVPSIZ:** Nonvolatile Program Memory Size

NVPSIZ				Size
0	0	0	0	None
0	0	0	1	8K bytes
0	0	1	0	16K bytes
0	0	1	1	32K bytes
0	1	0	0	Reserved
0	1	0	1	64K bytes
0	1	1	0	Reserved
0	1	1	1	128K bytes
1	0	0	0	Reserved
1	0	0	1	256K bytes
1	0	1	0	Reserved
1	0	1	1	Reserved
1	1	0	0	Reserved
1	1	0	1	Reserved
1	1	1	0	Reserved
1	1	1	1	Reserved

- **SRAMSIZ: Internal SRAM Size**

SRAMSIZ				Size
0	0	0	0	Reserved
0	0	0	1	1K bytes
0	0	1	0	2K bytes
0	0	1	1	Reserved
0	1	0	0	112K bytes
0	1	0	1	4K bytes
0	1	1	0	80K bytes
0	1	1	1	160K bytes
1	0	0	0	8K bytes
1	0	0	1	16K bytes
1	0	1	0	32K bytes
1	0	1	1	64K bytes
1	1	0	0	128K bytes
1	1	0	1	256K bytes
1	1	1	0	96K bytes
1	1	1	1	512K bytes

- **ARCH: Architecture Identifier**

ARCH		Architecture
Hex	Dec	
0x40	0100 0000	AT91x40 Series
0x63	0110 0011	AT91x63 Series
0x55	0101 0101	AT91x55 Series
0x42	0100 0010	AT91x42 Series
0x92	1001 0010	AT91x92 Series
0x34	0011 0100	AT91x34 Series

- **NVPTYP: Nonvolatile Program Memory Type**

NVPTYP			Memory
0	0	0	ROM
0	0	1	ROMless or on-chip Flash
1	0	0	SRAM emulating ROM

- **EXT: Extension Flag**

0 = Chip ID has a single register definition without extension

1 = An extended Chip ID exists.

26.5.10 Debug Unit Chip ID Extension Register

Name: DBGU_EXID

Access Type: Read-only

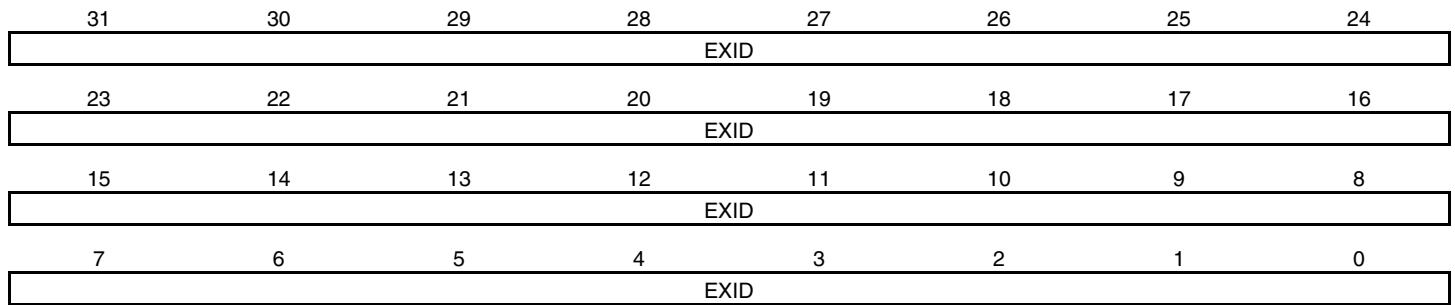

- **EXID: Chip ID Extension**

Reads 0 if the bit EXT in DBGU_CIDR is 0.



27. Parallel Input/Output Controller (PIO)

27.1 Overview

The Parallel Input/Output Controller (PIO) manages up to 32 fully programmable input/output lines. Each I/O line may be dedicated as a general-purpose I/O or be assigned to a function of an embedded peripheral. This assures effective optimization of the pins of a product.

Each I/O line is associated with a bit number in all of the 32-bit registers of the 32-bit wide User Interface.

Each I/O line of the PIO Controller features:

- An input change interrupt enabling level change on any I/O line.
- A glitch filter providing rejection of pulses lower than one-half of clock cycle.
- Multi-drive capability similar to an open drain I/O line.
- Control of the pull-up of the I/O line.
- Input visibility and output control.

The PIO Controller also features a synchronous output providing up to 32 bits of data output in a single write operation.

Important features of the PIO also include:

- Up to 32 Programmable I/O Lines
- Fully Programmable through Set/Clear Registers
- Multiplexing of Two Peripheral Functions per I/O Line
- For each I/O Line (Whether Assigned to a Peripheral or Used as General Purpose I/O)
 - Input Change Interrupt
 - Glitch Filter
 - Multi-drive Option Enables Driving in Open Drain
 - Programmable Pull-up on Each I/O Line
 - Pin Data Status Register, Supplies Visibility of the Level on the Pin at Any Time
- Synchronous Output, Provides Set and Clear of Several I/O lines in a Single Write

27.2 Block Diagram

Figure 27-1. Block Diagram

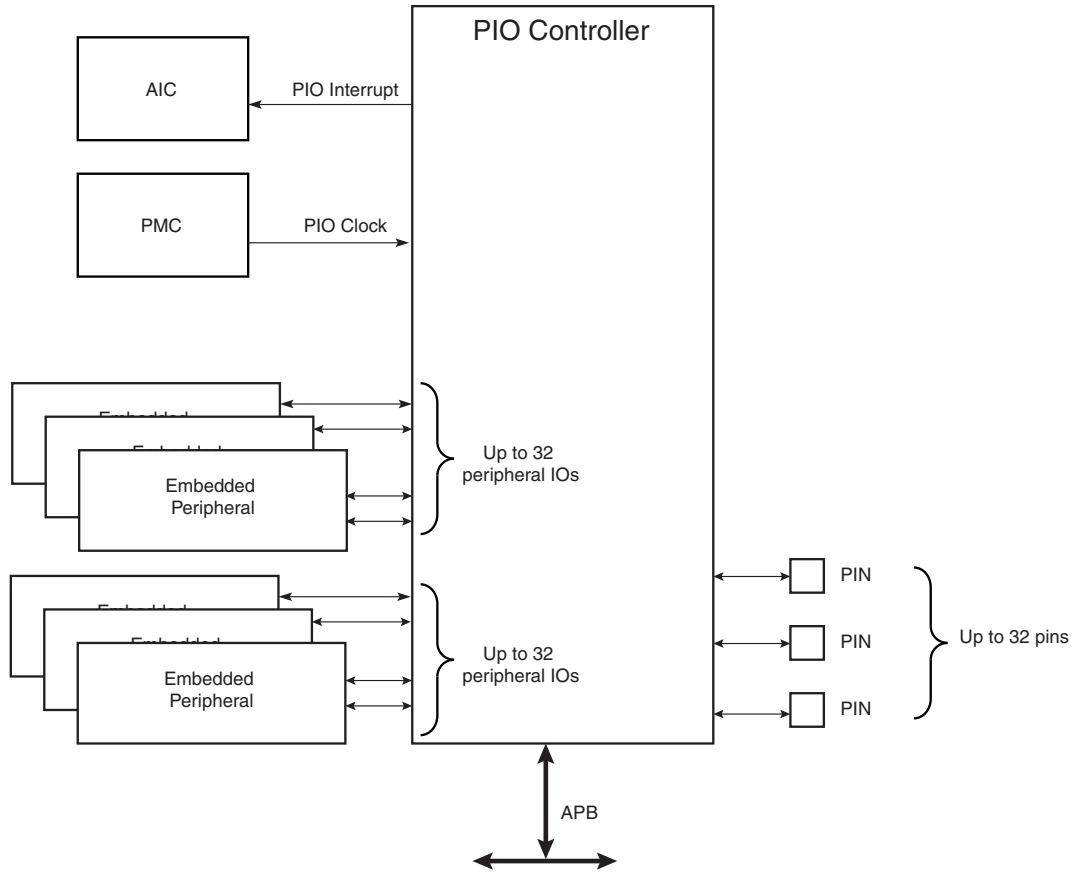
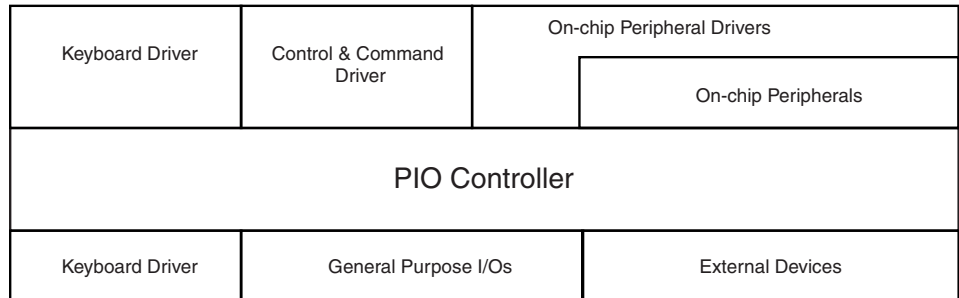

Figure 27-2. Application Block Diagram



27.3 Product Dependencies

27.3.1 Pin Multiplexing

Each pin is configurable, according to product definition as either a general-purpose I/O line only, or as an I/O line multiplexed with one or two peripheral I/Os. As the multiplexing is hardware-defined and thus product-dependent, the hardware designer and programmer must carefully determine the configuration of the PIO controllers required by their application. When an I/O line is general-purpose only, i.e. not multiplexed with any peripheral I/O, programming of the PIO Controller regarding the assignment to a peripheral has no effect and only the PIO Controller can control how the pin is driven by the product.

27.3.2 External Interrupt Lines

The interrupt signals FIQ and IRQ0 to IRQn are most generally multiplexed through the PIO Controllers. However, it is not necessary to assign the I/O line to the interrupt function as the PIO Controller has no effect on inputs and the interrupt lines (FIQ or IRQs) are used only as inputs.

27.3.3 Power Management

The Power Management Controller controls the PIO Controller clock in order to save power. Writing any of the registers of the user interface does not require the PIO Controller clock to be enabled. This means that the configuration of the I/O lines does not require the PIO Controller clock to be enabled.

However, when the clock is disabled, not all of the features of the PIO Controller are available. Note that the Input Change Interrupt and the read of the pin level require the clock to be validated.

After a hardware reset, the PIO clock is disabled by default (see Power Management Controller).

The user must configure the Power Management Controller before any access to the input line information.

27.3.4 Interrupt Generation

For interrupt handling, the PIO Controllers are considered as user peripherals. This means that the PIO Controller interrupt lines are connected among the interrupt sources 2 to 31. Refer to the PIO Controller peripheral identifier in the product description to identify the interrupt sources dedicated to the PIO Controllers.

The PIO Controller interrupt can be generated only if the PIO Controller clock is enabled.

27.4 Functional Description

The PIO Controller features up to 32 fully-programmable I/O lines. Most of the control logic associated to each I/O is represented in [Figure 27-3](#).

Figure 27-3. I/O Line Control Logic

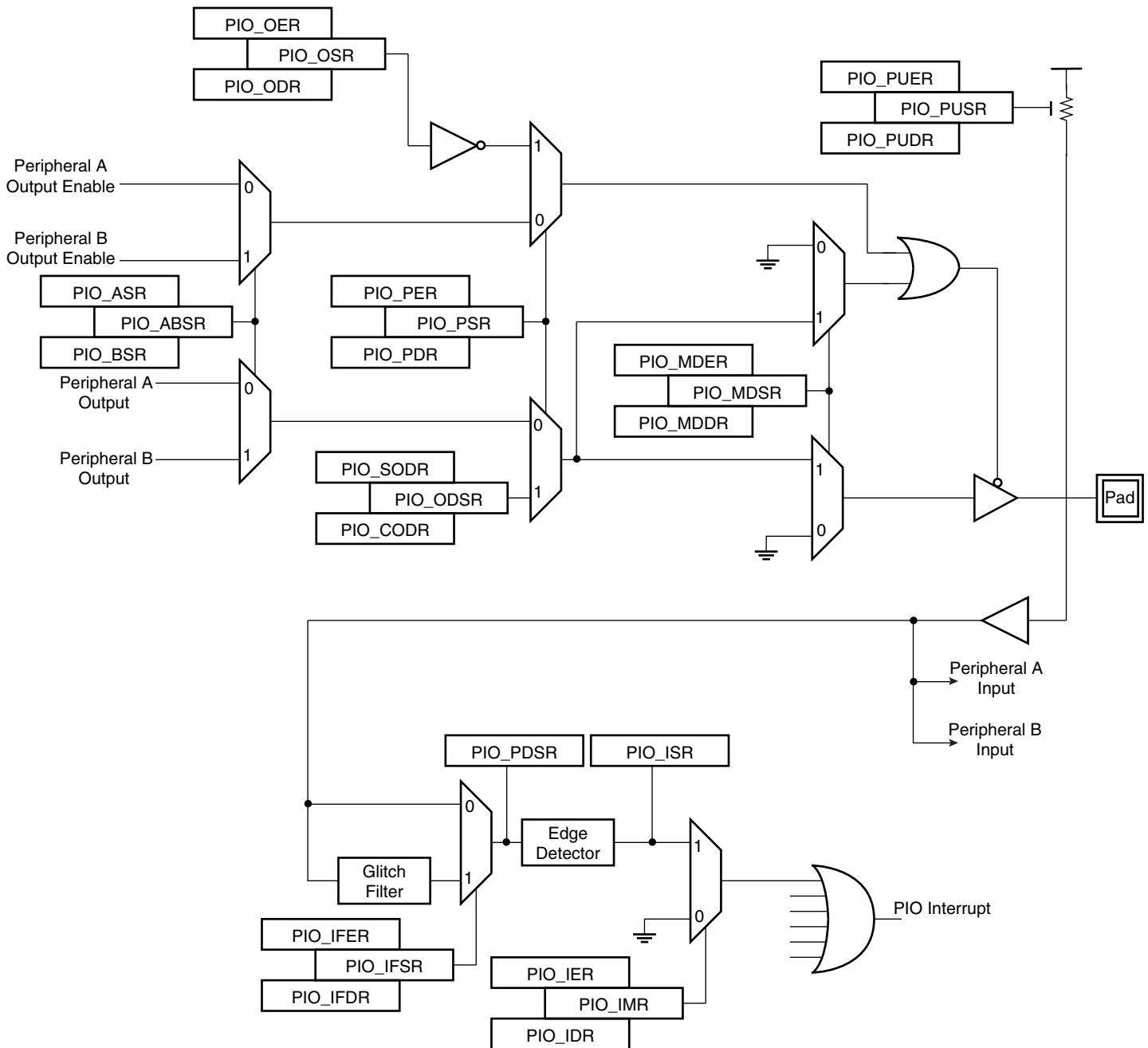

27.4.1 Pull-up Resistor Control

Each I/O line is designed with an embedded pull-up resistor. The internal pull-ups have a typical value of 200 kOhm (see the product electrical characteristics for more details about this value). The pull-up resistor can be enabled or disabled by writing respectively PIO_PUER (Pull-up Enable Register) and PIO_PUDR (Pull-up Disable Register). Writing in these registers results in setting or clearing the corresponding bit in PIO_PUSR (Pull-up Status Register). Reading a 1 in PIO_PUSR means the pull-up is disabled and reading a 0 means the pull-up is enabled.

Control of the pull-up resistor is possible regardless of the configuration of the I/O line.

After reset, all of the pull-ups are enabled, i.e. PIO_PUSR resets at the value 0x0.

27.4.2 I/O Line or Peripheral Function Selection

When a pin is multiplexed with one or two peripheral functions, the selection is controlled with the registers PIO_PER (PIO Enable Register) and PIO_PDR (PIO Disable Register). The register PIO_PSR (PIO Status Register) is the result of the set and clear registers and indicates whether the pin is controlled by the corresponding peripheral or by the PIO Controller. A value of 0 indicates that the pin is controlled by the corresponding on-chip peripheral selected in the PIO_ABSR (AB Select Status Register). A value of 1 indicates the pin is controlled by the PIO controller.

If a pin is used as a general purpose I/O line (not multiplexed with an on-chip peripheral), PIO_PER and PIO_PDR have no effect and PIO_PSR returns 1 for the corresponding bit.

After reset, most generally, the I/O lines are controlled by the PIO controller, i.e. PIO_PSR resets at 1. However, in some events, it is important that PIO lines are controlled by the peripheral (as in the case of memory chip select lines that must be driven inactive after reset or for address lines that must be driven low for booting out of an external memory). Thus, the reset value of PIO_PSR is defined at the product level, depending on the multiplexing of the device.

27.4.3 Peripheral A or B Selection

The PIO Controller provides multiplexing of up to two peripheral functions on a single pin. The selection is performed by writing PIO_ASR (A Select Register) and PIO_BSR (Select B Register). PIO_ABSR (AB Select Status Register) indicates which peripheral line is currently selected. For each pin, the corresponding bit at level 0 means peripheral A is selected whereas the corresponding bit at level 1 indicates that peripheral B is selected.

Note that multiplexing of peripheral lines A and B only affects the output line. The peripheral input lines are always connected to the pin input.

After reset, PIO_ABSR is 0, thus indicating that all the PIO lines are configured on peripheral A. However, peripheral A generally does not drive the pin as the PIO Controller resets in I/O line mode.

Writing in PIO_ASR and PIO_BSR manages PIO_ABSR regardless of the configuration of the pin. However, assignment of a pin to a peripheral function requires a write in the corresponding peripheral selection register (PIO_ASR or PIO_BSR) in addition to a write in PIO_PDR.

27.4.4 Output Control

When the I/O line is assigned to a peripheral function, i.e. the corresponding bit in PIO_PSR is at 0, the drive of the I/O line is controlled by the peripheral. Peripheral A or B, depending on the value in PIO_ABSR, determines whether the pin is driven or not.

When the I/O line is controlled by the PIO controller, the pin can be configured to be driven. This is done by writing PIO_OER (Output Enable Register) and PIO_PDR (Output Disable Register). The results of these write operations are detected in PIO_OSR (Output Status Register). When a bit in this register is at 0, the corresponding I/O line is used as an input only. When the bit is at 1, the corresponding I/O line is driven by the PIO controller.

The level driven on an I/O line can be determined by writing in PIO_SODR (Set Output Data Register) and PIO_CODR (Clear Output Data Register). These write operations respectively set and clear PIO_ODSR (Output Data Status Register), which represents the data driven on the I/O lines. Writing in PIO_OER and PIO_ODR manages PIO_OSR whether the pin is configured to

be controlled by the PIO controller or assigned to a peripheral function. This enables configuration of the I/O line prior to setting it to be managed by the PIO Controller.

Similarly, writing in PIO_SODR and PIO_CODR effects PIO_ODSR. This is important as it defines the first level driven on the I/O line.

27.4.5 Synchronous Data Output

Using the write operations in PIO_SODR and PIO_CODR can require that several instructions be executed in order to define values on several bits. Both clearing and setting I/O lines on an 8-bit port, for example, cannot be done at the same time, and thus might limit the application covered by the PIO Controller.

To avoid these inconveniences, the PIO Controller features a Synchronous Data Output to clear and set a number of I/O lines in a single write. This is performed by authorizing the writing of PIO_ODSR (Output Data Status Register) from the register set PIO_OWER (Output Write Enable Register), PIO_OWDR (Output Write Disable Register) and PIO_OWSR (Output Write Status Register). The value of PIO_OWSR register is user-definable by writing in PIO_OWER and PIO_OWDR. It is used by the PIO Controller as a PIO_ODSR write authorization mask. Authorizing the write of PIO_ODSR on a user-definable number of bits is especially useful, as it guarantees that the unauthorized bit will not be changed when writing it and thus avoids the need of a time consuming read-modify-write operation.

After reset, the synchronous data output is disabled on all the I/O lines as PIO_OWSR resets at 0x0.

27.4.6 Multi Drive Control (Open Drain)

Each I/O can be independently programmed in Open Drain by using the Multi Drive feature. This feature permits several drivers to be connected on the I/O line which is driven low only by each device. An external pull-up resistor (or enabling of the internal one) is generally required to guarantee a high level on the line.

The Multi Drive feature is controlled by PIO_MDER (Multi-driver Enable Register) and PIO_MDDR (Multi-driver Disable Register). The Multi Drive can be selected whether the I/O line is controlled by the PIO controller or assigned to a peripheral function. PIO_MDSR (Multi-driver Status Register) indicates the pins that are configured to support external drivers.

After reset, the Multi Drive feature is disabled on all pins, i.e. PIO_MDSR resets at value 0x0.

27.4.7 Output Line Timings

Figure 27-4 shows how the outputs are driven either by writing PIO_SODR or PIO_CODR, or by directly writing PIO_ODSR. This last case is valid only if the corresponding bit in PIO_OWSR is set. Figure 27-4 also shows when the feedback in PIO_PDSR is available.

Figure 27-4. Output Line Timings

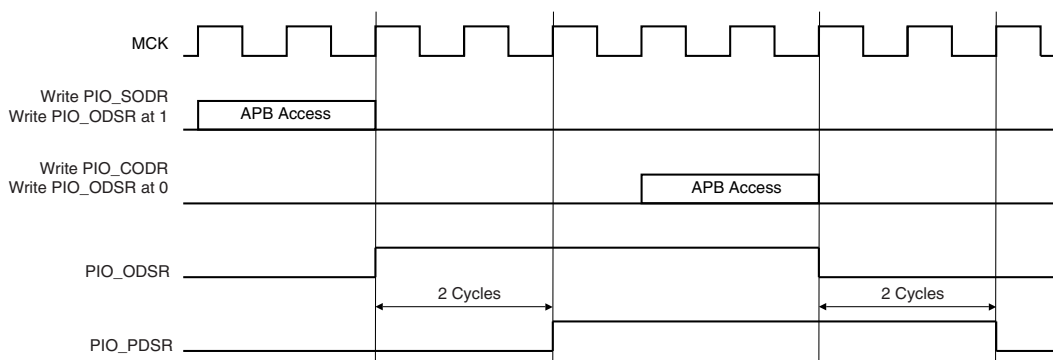

27.4.8 Inputs

The level on each I/O line can be read through PIO_PDSR (Pin Data Status Register). This register indicates the level of the I/O lines regardless of their configuration, whether uniquely as an input or driven by the PIO controller or driven by a peripheral.

Reading the I/O line levels requires the clock of the PIO controller to be enabled, otherwise PIO_PDSR reads the levels present on the I/O line at the time the clock was disabled.

27.4.9 Input Glitch Filtering

Optional input glitch filters are independently programmable on each I/O line. When the glitch filter is enabled, a glitch with a duration of less than 1/2 Master Clock (MCK) cycle is automatically rejected, while a pulse with a duration of 1 Master Clock cycle or more is accepted. For pulse durations between 1/2 Master Clock cycle and 1 Master Clock cycle the pulse may or may not be taken into account, depending on the precise timing of its occurrence. Thus for a pulse to be visible it must exceed 1 Master Clock cycle, whereas for a glitch to be reliably filtered out, its duration must not exceed 1/2 Master Clock cycle. The filter introduces one Master Clock cycle latency if the pin level change occurs before a rising edge. However, this latency does not appear if the pin level change occurs before a falling edge. This is illustrated in Figure 27-5.

The glitch filters are controlled by the register set; PIO_IFER (Input Filter Enable Register), PIO_IFDR (Input Filter Disable Register) and PIO_IFSR (Input Filter Status Register). Writing PIO_IFER and PIO_IFDR respectively sets and clears bits in PIO_IFSR. This last register enables the glitch filter on the I/O lines.

When the glitch filter is enabled, it does not modify the behavior of the inputs on the peripherals. It acts only on the value read in PIO_PDSR and on the input change interrupt detection. The glitch filters require that the PIO Controller clock is enabled.

Figure 27-5. Input Glitch Filter Timing

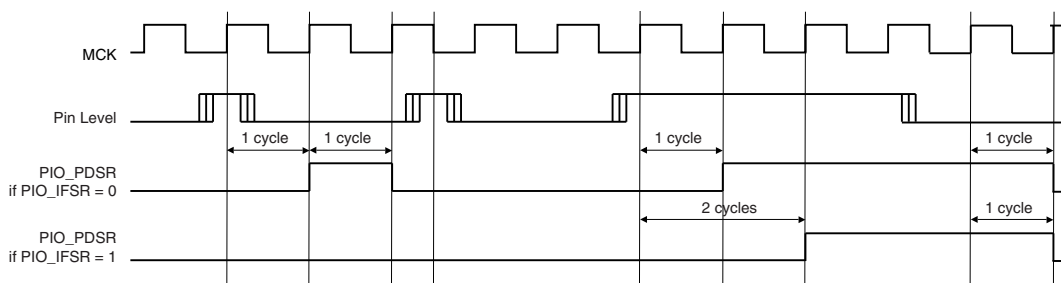

27.4.10 Input Change Interrupt

The PIO Controller can be programmed to generate an interrupt when it detects an input change on an I/O line. The Input Change Interrupt is controlled by writing PIO_IER (Interrupt Enable Register) and PIO_IDR (Interrupt Disable Register), which respectively enable and disable the input change interrupt by setting and clearing the corresponding bit in PIO_IMR (Interrupt Mask Register). As Input change detection is possible only by comparing two successive samplings of the input of the I/O line, the PIO Controller clock must be enabled. The Input Change Interrupt is available, regardless of the configuration of the I/O line, i.e. configured as an input only, controlled by the PIO Controller or assigned to a peripheral function.

When an input change is detected on an I/O line, the corresponding bit in PIO_ISR (Interrupt Status Register) is set. If the corresponding bit in PIO_IMR is set, the PIO Controller interrupt line is asserted. The interrupt signals of the thirty-two channels are ORed-wired together to generate a single interrupt signal to the Advanced Interrupt Controller.

When the software reads PIO_ISR, all the interrupts are automatically cleared. This signifies that all the interrupts that are pending when PIO_ISR is read must be handled.

Figure 27-6. Input Change Interrupt Timings

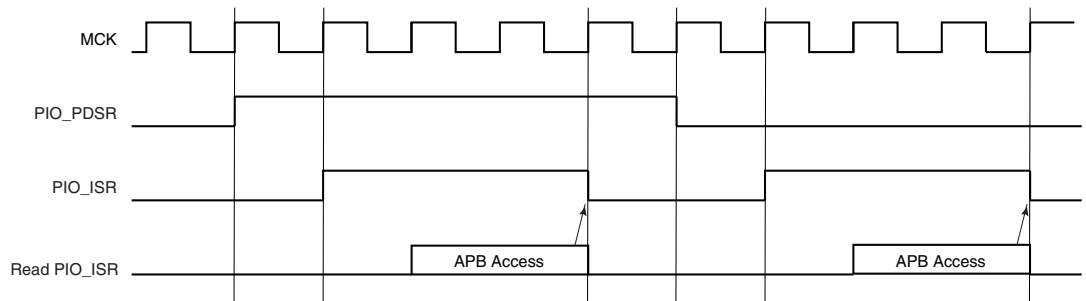

27.5 I/O Lines Programming Example

The programming example shown in [Table 27-1](#) below is used to define the following configuration.

- 4-bit output port on I/O lines 0 to 3, (should be written in a single write operation), open-drain, with pull-up resistor
- Four output signals on I/O lines 4 to 7 (to drive LEDs for example), driven high and low, no pull-up resistor
- Four input signals on I/O lines 8 to 11 (to read push-button states for example), with pull-up resistors, glitch filters and input change interrupts
- Four input signals on I/O line 12 to 15 to read an external device status (polled, thus no input change interrupt), no pull-up resistor, no glitch filter
- I/O lines 16 to 19 assigned to peripheral A functions with pull-up resistor
- I/O lines 20 to 23 assigned to peripheral B functions, no pull-up resistor
- I/O lines 24 to 27 assigned to peripheral A with Input Change Interrupt and pull-up resistor

Table 27-1. Programming Example

Register	Value to be Written
PIO_PER	0x0000 FFFF
PIO_PDR	0x0FFF 0000

Table 27-1. Programming Example

PIO_OER	0x0000 00FF
PIO_ODR	0x0FFF FF00
PIO_IFER	0x0000 0F00
PIO_IFDR	0x0FFF F0FF
PIO_SODR	0x0000 0000
PIO_CODR	0x0FFF FFFF
PIO_IER	0x0F00 0F00
PIO_IDR	0x00FF F0FF
PIO_MDER	0x0000 000F
PIO_MDDR	0x0FFF FFF0
PIO_PUDR	0x00F0 00F0
PIO_PUER	0x0F0F FF0F
PIO_ASR	0x0F0F 0000
PIO_BSR	0x00F0 0000
PIO_OWER	0x0000 000F
PIO_OWDR	0x0FFF FFF0

27.6 Parallel Input/Output Controller (PIO) User Interface

Each I/O line controlled by the PIO Controller is associated with a bit in each of the PIO Controller User Interface registers. Each register is 32 bits wide. If a parallel I/O line is not defined, writing to the corresponding bits has no effect. Undefined bits read zero. If the I/O line is not multiplexed with any peripheral, the I/O line is controlled by the PIO Controller and PIO_PSR returns 1 systematically.

Table 27-2. PIO Register Mapping

Offset	Register	Name	Access	Reset Value
0x0000	PIO Enable Register	PIO_PER	Write-only	–
0x0004	PIO Disable Register	PIO_PDR	Write-only	–
0x0008	PIO Status Register ⁽¹⁾	PIO_PSR	Read-only	0x0000 0000
0x000C	Reserved			
0x0010	PIO Output Enable Register	PIO_OER	Write-only	–
0x0014	PIO Output Disable Register	PIO_ODR	Write-only	–
0x0018	PIO Output Status Register	PIO_OSR	Read-only	0x0000 0000
0x001C	Reserved			
0x0020	PIO Glitch Input Filter Enable Register	PIO_IFER	Write-only	–
0x0024	PIO Glitch Input Filter Disable Register	PIO_IFDR	Write-only	–
0x0028	PIO Glitch Input Filter Status Register	PIO_IFSR	Read-only	0x0000 0000
0x002C	Reserved			
0x0030	PIO Set Output Data Register	PIO_SODR	Write-only	–
0x0034	PIO Clear Output Data Register	PIO_CODR	Write-only	–
0x0038	PIO Output Data Status Register ⁽²⁾	PIO_ODSR	Read-only	0x0000 0000
0x003C	PIO Pin Data Status Register ⁽³⁾	PIO_PDSR	Read-only	
0x0040	PIO Interrupt Enable Register	PIO_IER	Write-only	–
0x0044	PIO Interrupt Disable Register	PIO_IDR	Write-only	–
0x0048	PIO Interrupt Mask Register	PIO_IMR	Read-only	0x0000 0000
0x004C	PIO Interrupt Status Register ⁽⁴⁾	PIO_ISR	Read-only	0x0000 0000
0x0050	PIO Multi-driver Enable Register	PIO_MDER	Write-only	–
0x0054	PIO Multi-driver Disable Register	PIO_MDDR	Write-only	–
0x0058	PIO Multi-driver Status Register	PIO_MDSR	Read-only	0x0000 0000
0x005C	Reserved			
0x0060	PIO Pull-up Disable Register	PIO_PUDR	Write-only	–
0x0064	PIO Pull-up Enable Register	PIO_PUER	Write-only	–
0x0068	PIO Pad Pull-up Status Register	PIO_PUSR	Read-only	0x0000 0000
0x006C	Reserved			
0x0070	PIO Peripheral A Select Register ⁽⁵⁾	PIO_ASR	Write-only	–
0x0074	PIO Peripheral B Select Register ⁽⁵⁾	PIO_BSR	Write-only	–
0x0078	PIO AB Status Register ⁽⁵⁾	PIO_ABSR	Read-only	0x0000 0000

Table 27-2. PIO Register Mapping (Continued)

Offset	Register	Name	Access	Reset Value
0x007C to 0x009C	Reserved			
0x00A0	PIO Output Write Enable	PIO_OWER	Write-only	–
0x00A4	PIO Output Write Disable	PIO_OWDR	Write-only	–
0x00A8	PIO Output Write Status Register	PIO_OWSR	Read-only	0x0000 0000
0x00AC	Reserved			

- Notes:
1. Reset value of PIO_PSR depends on the product implementation.
 2. PIO_ODSR is Read-only or Read/Write depending on PIO_OWSR I/O lines.
 3. Reset value of PIO_PDSR depends on the level of the I/O lines.
 4. PIO_ISR is reset at 0x0. However, the first read of the register may read a different value as input changes may have occurred.
 5. Only this set of registers clears the status by writing 1 in the first register and sets the status by writing 1 in the second register.

27.6.1 PIO Enable Register

Name: PIO_PER

Access Type: Write-only

31	30	29	28	27	26	25	24
P31	P30	P29	P28	P27	P26	P25	P24
23	22	21	20	19	18	17	16
P23	P22	P21	P20	P19	P18	P17	P16
15	14	13	12	11	10	9	8
P15	P14	P13	P12	P11	P10	P9	P8
7	6	5	4	3	2	1	0
P7	P6	P5	P4	P3	P2	P1	P0

- **P0 - P31: PIO Enable**

0 = No effect.

1 = Enables the PIO to control the corresponding pin (disables peripheral control of the pin).

27.6.2 PIO Disable Register

Name: PIO_PDR

Access Type: Write-only

31	30	29	28	27	26	25	24
P31	P30	P29	P28	P27	P26	P25	P24
23	22	21	20	19	18	17	16
P23	P22	P21	P20	P19	P18	P17	P16
15	14	13	12	11	10	9	8
P15	P14	P13	P12	P11	P10	P9	P8
7	6	5	4	3	2	1	0
P7	P6	P5	P4	P3	P2	P1	P0

- **P0 - P31: PIO Disable**

0 = No effect.

1 = Disables the PIO from controlling the corresponding pin (enables peripheral control of the pin).

27.6.3 PIO Status Register

Name: PIO_PSR

Access Type: Read-only

31	30	29	28	27	26	25	24
P31	P30	P29	P28	P27	P26	P25	P24
23	22	21	20	19	18	17	16
P23	P22	P21	P20	P19	P18	P17	P16
15	14	13	12	11	10	9	8
P15	P14	P13	P12	P11	P10	P9	P8
7	6	5	4	3	2	1	0
P7	P6	P5	P4	P3	P2	P1	P0

- **P0 - P31: PIO Status**

0 = PIO is inactive on the corresponding I/O line (peripheral is active).

1 = PIO is active on the corresponding I/O line (peripheral is inactive).

27.6.4 PIO Output Enable Register

Name: PIO_OER

Access Type: Write-only

31	30	29	28	27	26	25	24
P31	P30	P29	P28	P27	P26	P25	P24
23	22	21	20	19	18	17	16
P23	P22	P21	P20	P19	P18	P17	P16
15	14	13	12	11	10	9	8
P15	P14	P13	P12	P11	P10	P9	P8
7	6	5	4	3	2	1	0
P7	P6	P5	P4	P3	P2	P1	P0

- **P0 - P31: Output Enable**

0 = No effect.

1 = Enables the output on the I/O line.

27.6.5 PIO Output Disable Register

Name: PIO_ODR

Access Type: Write-only

31	30	29	28	27	26	25	24
P31	P30	P29	P28	P27	P26	P25	P24
23	22	21	20	19	18	17	16
P23	P22	P21	P20	P19	P18	P17	P16
15	14	13	12	11	10	9	8
P15	P14	P13	P12	P11	P10	P9	P8
7	6	5	4	3	2	1	0
P7	P6	P5	P4	P3	P2	P1	P0

• **P0 - P31: Output Disable**

0 = No effect.

1 = Disables the output on the I/O line.

27.6.6 PIO Output Status Register

Name: PIO_OSR

Access Type: Read-only

31	30	29	28	27	26	25	24
P31	P30	P29	P28	P27	P26	P25	P24
23	22	21	20	19	18	17	16
P23	P22	P21	P20	P19	P18	P17	P16
15	14	13	12	11	10	9	8
P15	P14	P13	P12	P11	P10	P9	P8
7	6	5	4	3	2	1	0
P7	P6	P5	P4	P3	P2	P1	P0

• **P0 - P31: Output Status**

0 = The I/O line is a pure input.

1 = The I/O line is enabled in output.

27.6.7 PIO Input Filter Enable Register

Name: PIO_IFER

Access Type: Write-only

31	30	29	28	27	26	25	24
P31	P30	P29	P28	P27	P26	P25	P24
23	22	21	20	19	18	17	16
P23	P22	P21	P20	P19	P18	P17	P16
15	14	13	12	11	10	9	8
P15	P14	P13	P12	P11	P10	P9	P8
7	6	5	4	3	2	1	0
P7	P6	P5	P4	P3	P2	P1	P0

- **P0 - P31: Input Filter Enable**

0 = No effect.

1 = Enables the input glitch filter on the I/O line.

27.6.8 PIO Input Filter Disable Register

Name: PIO_IFDR

Access Type: Write-only

31	30	29	28	27	26	25	24
P31	P30	P29	P28	P27	P26	P25	P24
23	22	21	20	19	18	17	16
P23	P22	P21	P20	P19	P18	P17	P16
15	14	13	12	11	10	9	8
P15	P14	P13	P12	P11	P10	P9	P8
7	6	5	4	3	2	1	0
P7	P6	P5	P4	P3	P2	P1	P0

- **P0 - P31: Input Filter Disable**

0 = No effect.

1 = Disables the input glitch filter on the I/O line.

27.6.9 PIO Input Filter Status Register

Name: PIO_IFSR

Access Type: Read-only

31	30	29	28	27	26	25	24
P31	P30	P29	P28	P27	P26	P25	P24
23	22	21	20	19	18	17	16
P23	P22	P21	P20	P19	P18	P17	P16
15	14	13	12	11	10	9	8
P15	P14	P13	P12	P11	P10	P9	P8
7	6	5	4	3	2	1	0
P7	P6	P5	P4	P3	P2	P1	P0

• **P0 - P31: Input Filter Status**

0 = The input glitch filter is disabled on the I/O line.

1 = The input glitch filter is enabled on the I/O line.

27.6.10 PIO Set Output Data Register

Name: PIO_SODR

Access Type: Write-only

31	30	29	28	27	26	25	24
P31	P30	P29	P28	P27	P26	P25	P24
23	22	21	20	19	18	17	16
P23	P22	P21	P20	P19	P18	P17	P16
15	14	13	12	11	10	9	8
P15	P14	P13	P12	P11	P10	P9	P8
7	6	5	4	3	2	1	0
P7	P6	P5	P4	P3	P2	P1	P0

• **P0 - P31: Set Output Data**

0 = No effect.

1 = Sets the data to be driven on the I/O line.

27.6.11 PIO Clear Output Data Register

Name: PIO_CODR

Access Type: Write-only

31	30	29	28	27	26	25	24
P31	P30	P29	P28	P27	P26	P25	P24
23	22	21	20	19	18	17	16
P23	P22	P21	P20	P19	P18	P17	P16
15	14	13	12	11	10	9	8
P15	P14	P13	P12	P11	P10	P9	P8
7	6	5	4	3	2	1	0
P7	P6	P5	P4	P3	P2	P1	P0

- **P0 - P31: Set Output Data**

0 = No effect.

1 = Clears the data to be driven on the I/O line.

27.6.12 PIO Output Data Status Register

Name: PIO_ODSR

Access Type: Read-only or Read/Write

31	30	29	28	27	26	25	24
P31	P30	P29	P28	P27	P26	P25	P24
23	22	21	20	19	18	17	16
P23	P22	P21	P20	P19	P18	P17	P16
15	14	13	12	11	10	9	8
P15	P14	P13	P12	P11	P10	P9	P8
7	6	5	4	3	2	1	0
P7	P6	P5	P4	P3	P2	P1	P0

- **P0 - P31: Output Data Status**

0 = The data to be driven on the I/O line is 0.

1 = The data to be driven on the I/O line is 1.

27.6.13 PIO Pin Data Status Register

Name: PIO_PDSR

Access Type: Read-only

31	30	29	28	27	26	25	24
P31	P30	P29	P28	P27	P26	P25	P24
23	22	21	20	19	18	17	16
P23	P22	P21	P20	P19	P18	P17	P16
15	14	13	12	11	10	9	8
P15	P14	P13	P12	P11	P10	P9	P8
7	6	5	4	3	2	1	0
P7	P6	P5	P4	P3	P2	P1	P0

- **P0 - P31: Output Data Status**

0 = The I/O line is at level 0.

1 = The I/O line is at level 1.

27.6.14 PIO Interrupt Enable Register

Name: PIO_IER

Access Type: Write-only

31	30	29	28	27	26	25	24
P31	P30	P29	P28	P27	P26	P25	P24
23	22	21	20	19	18	17	16
P23	P22	P21	P20	P19	P18	P17	P16
15	14	13	12	11	10	9	8
P15	P14	P13	P12	P11	P10	P9	P8
7	6	5	4	3	2	1	0
P7	P6	P5	P4	P3	P2	P1	P0

- **P0 - P31: Input Change Interrupt Enable**

0 = No effect.

1 = Enables the Input Change Interrupt on the I/O line.

27.6.15 PIO Interrupt Disable Register

Name: PIO_IDR

Access Type: Write-only

31	30	29	28	27	26	25	24
P31	P30	P29	P28	P27	P26	P25	P24
23	22	21	20	19	18	17	16
P23	P22	P21	P20	P19	P18	P17	P16
15	14	13	12	11	10	9	8
P15	P14	P13	P12	P11	P10	P9	P8
7	6	5	4	3	2	1	0
P7	P6	P5	P4	P3	P2	P1	P0

- **P0 - P31: Input Change Interrupt Disable**

0 = No effect.

1 = Disables the Input Change Interrupt on the I/O line.

27.6.16 PIO Interrupt Mask Register

Name: PIO_IMR

Access Type: Read-only

31	30	29	28	27	26	25	24
P31	P30	P29	P28	P27	P26	P25	P24
23	22	21	20	19	18	17	16
P23	P22	P21	P20	P19	P18	P17	P16
15	14	13	12	11	10	9	8
P15	P14	P13	P12	P11	P10	P9	P8
7	6	5	4	3	2	1	0
P7	P6	P5	P4	P3	P2	P1	P0

- **P0 - P31: Input Change Interrupt Mask**

0 = Input Change Interrupt is disabled on the I/O line.

1 = Input Change Interrupt is enabled on the I/O line.

27.6.17 PIO Interrupt Status Register

Name: PIO_IMR

Access Type: Read-only

31	30	29	28	27	26	25	24
P31	P30	P29	P28	P27	P26	P25	P24
23	22	21	20	19	18	17	16
P23	P22	P21	P20	P19	P18	P17	P16
15	14	13	12	11	10	9	8
P15	P14	P13	P12	P11	P10	P9	P8
7	6	5	4	3	2	1	0
P7	P6	P5	P4	P3	P2	P1	P0

- **P0 - P31: Input Change Interrupt Mask**

0 = No Input Change has been detected on the I/O line since PIO_ISR was last read or since reset.

1 = At least one Input Change has been detected on the I/O line since PIO_ISR was last read or since reset.

27.6.18 PIO Multi-driver Enable Register

Name: PIO_MDER

Access Type: Write-only

31	30	29	28	27	26	25	24
P31	P30	P29	P28	P27	P26	P25	P24
23	22	21	20	19	18	17	16
P23	P22	P21	P20	P19	P18	P17	P16
15	14	13	12	11	10	9	8
P15	P14	P13	P12	P11	P10	P9	P8
7	6	5	4	3	2	1	0
P7	P6	P5	P4	P3	P2	P1	P0

- **P0 - P31: Multi Drive Enable**

0 = No effect.

1 = Enables Multi Drive on the I/O line.

27.6.19 PIO Multi-driver Disable Register

Name: PIO_MDDR

Access Type: Write-only

31	30	29	28	27	26	25	24
P31	P30	P29	P28	P27	P26	P25	P24
23	22	21	20	19	18	17	16
P23	P22	P21	P20	P19	P18	P17	P16
15	14	13	12	11	10	9	8
P15	P14	P13	P12	P11	P10	P9	P8
7	6	5	4	3	2	1	0
P7	P6	P5	P4	P3	P2	P1	P0

- P0 - P31: Multi Drive Disable**

0 = No effect.

1 = Disables Multi Drive on the I/O line.

27.6.20 PIO Multi-driver Status Register

Name: PIO_MDSR

Access Type: Read-only

31	30	29	28	27	26	25	24
P31	P30	P29	P28	P27	P26	P25	P24
23	22	21	20	19	18	17	16
P23	P22	P21	P20	P19	P18	P17	P16
15	14	13	12	11	10	9	8
P15	P14	P13	P12	P11	P10	P9	P8
7	6	5	4	3	2	1	0
P7	P6	P5	P4	P3	P2	P1	P0

- P0 - P31: Multi Drive Status**

0 = The Multi Drive is disabled on the I/O line. The pin is driven at high and low level.

1 = The Multi Drive is enabled on the I/O line. The pin is driven at low level only.



27.6.21 PIO Pull-Up Disable Register

Name: PIO_PUDR

Access Type: Write-only

31	30	29	28	27	26	25	24
P31	P30	P29	P28	P27	P26	P25	P24
23	22	21	20	19	18	17	16
P23	P22	P21	P20	P19	P18	P17	P16
15	14	13	12	11	10	9	8
P15	P14	P13	P12	P11	P10	P9	P8
7	6	5	4	3	2	1	0
P7	P6	P5	P4	P3	P2	P1	P0

- **P0 - P31: Pull-Up Disable**

0 = No effect.

1 = Disables the pull-up resistor on the I/O line.

27.6.22 PIO Pull-Up Enable Register

Name: PIO_PUER

Access Type: Write-only

31	30	29	28	27	26	25	24
P31	P30	P29	P28	P27	P26	P25	P24
23	22	21	20	19	18	17	16
P23	P22	P21	P20	P19	P18	P17	P16
15	14	13	12	11	10	9	8
P15	P14	P13	P12	P11	P10	P9	P8
7	6	5	4	3	2	1	0
P7	P6	P5	P4	P3	P2	P1	P0

- **P0 - P31: Pull-Up Enable**

0 = No effect.

1 = Enables the pull-up resistor on the I/O line.

27.6.23 PIO Pad Pull-Up Status Register

Name: PIO_PUSR

Access Type: Read-only

31	30	29	28	27	26	25	24
P31	P30	P29	P28	P27	P26	P25	P24
23	22	21	20	19	18	17	16
P23	P22	P21	P20	P19	P18	P17	P16
15	14	13	12	11	10	9	8
P15	P14	P13	P12	P11	P10	P9	P8
7	6	5	4	3	2	1	0
P7	P6	P5	P4	P3	P2	P1	P0

- **P0 - P31: Pull-Up Status**

0 = Pull-up resistor is enabled on the I/O line.

1 = Pull-up resistor is disabled on the I/O line.

27.6.24 PIO Peripheral A Select Register

Name: PIO_ASX

Access Type: Write-only

31	30	29	28	27	26	25	24
P31	P30	P29	P28	P27	P26	P25	P24
23	22	21	20	19	18	17	16
P23	P22	P21	P20	P19	P18	P17	P16
15	14	13	12	11	10	9	8
P15	P14	P13	P12	P11	P10	P9	P8
7	6	5	4	3	2	1	0
P7	P6	P5	P4	P3	P2	P1	P0

- **P0 - P31: Peripheral A Select**

0 = No effect.

1 = Assigns the I/O line to the Peripheral A function.



27.6.25 PIO Peripheral B Select Register

Name: PIO_BSR

Access Type: Write-only

31	30	29	28	27	26	25	24
P31	P30	P29	P28	P27	P26	P25	P24
23	22	21	20	19	18	17	16
P23	P22	P21	P20	P19	P18	P17	P16
15	14	13	12	11	10	9	8
P15	P14	P13	P12	P11	P10	P9	P8
7	6	5	4	3	2	1	0
P7	P6	P5	P4	P3	P2	P1	P0

• **P0 - P31: Peripheral B Select**

0 = No effect.

1 = Assigns the I/O line to the peripheral B function.

27.6.26 PIO Peripheral AB Status Register

Name: PIO_ABSR

Access Type: Read-only

31	30	29	28	27	26	25	24
P31	P30	P29	P28	P27	P26	P25	P24
23	22	21	20	19	18	17	16
P23	P22	P21	P20	P19	P18	P17	P16
15	14	13	12	11	10	9	8
P15	P14	P13	P12	P11	P10	P9	P8
7	6	5	4	3	2	1	0
P7	P6	P5	P4	P3	P2	P1	P0

• **P0 - P31: Peripheral A B Status**

0 = The I/O line is assigned to the Peripheral A.

1 = The I/O line is assigned to the Peripheral B.

27.6.27 PIO Output Write Enable Register

Name: PIO_OWER

Access Type: Write-only

31	30	29	28	27	26	25	24
P31	P30	P29	P28	P27	P26	P25	P24
23	22	21	20	19	18	17	16
P23	P22	P21	P20	P19	P18	P17	P16
15	14	13	12	11	10	9	8
P15	P14	P13	P12	P11	P10	P9	P8
7	6	5	4	3	2	1	0
P7	P6	P5	P4	P3	P2	P1	P0

- **P0 - P31: Output Write Enable**

0 = No effect.

1 = Enables writing PIO_ODSR for the I/O line.

27.6.28 PIO Output Write Disable Register

Name: PIO_OWDR

Access Type: Write-only

31	30	29	28	27	26	25	24
P31	P30	P29	P28	P27	P26	P25	P24
23	22	21	20	19	18	17	16
P23	P22	P21	P20	P19	P18	P17	P16
15	14	13	12	11	10	9	8
P15	P14	P13	P12	P11	P10	P9	P8
7	6	5	4	3	2	1	0
P7	P6	P5	P4	P3	P2	P1	P0

- **P0 - P31: Output Write Disable**

0 = No effect.

1 = Disables writing PIO_ODSR for the I/O line.

27.6.29 PIO Output Write Status Register

Name: PIO_OWSR

Access Type: Read-only

31	30	29	28	27	26	25	24
P31	P30	P29	P28	P27	P26	P25	P24
23	22	21	20	19	18	17	16
P23	P22	P21	P20	P19	P18	P17	P16
15	14	13	12	11	10	9	8
P15	P14	P13	P12	P11	P10	P9	P8
7	6	5	4	3	2	1	0
P7	P6	P5	P4	P3	P2	P1	P0

- **P0 - P31: Output Write Status**

0 = Writing PIO_ODSR does not affect the I/O line.

1 = Writing PIO_ODSR affects the I/O line.

28. Serial Peripheral Interface (SPI)

28.1 Overview

The Serial Peripheral Interface (SPI) circuit is a synchronous serial data link that provides communication with external devices in Master or Slave Mode. It also allows communication between processors if an external processor is connected to the system.

The Serial Peripheral Interface is a shift register that serially transmits data bits to other SPIs. During a data transfer, one SPI system acts as the master that controls the data flow, while the other system acts as the slave, having data shifted into and out of it by the master. Different CPUs can take turn being masters (Multiple Master Protocol versus Single Master Protocol where one CPU is always the master while all of the others are always slaves), and one master may simultaneously shift data into multiple slaves. However, only one slave may drive its output to write data back to the master at any given time.

A slave device is selected when the master asserts its NSS signal. If multiple slave devices exist, the master generates a separate slave select signal for each slave (NPCS).

The SPI system consists of two data lines and two control lines:

- Master Out Slave In (MOSI): This data line supplies the output data from the master shifted into the input(s) of the slave(s).
- Master In Slave Out (MISO): This data line supplies the output data from a slave to the input of the master. There may be no more than one slave transmitting data during any particular transfer.
- Serial Clock (SPCK): This control line is driven by the master and regulates the flow of the data bits. The master may transmit data at a variety of baud rates; the SPCK line cycles once for each bit that is transmitted.
- Slave Select (NSS): This control line allows slaves to be turned on and off by hardware.

The main features of the SPI are:

- Supports Communication with Serial External Devices
 - 4 Chip Selects with External Decoder Support Allow Communication with Up to 15 Peripherals
 - Serial Memories, such as DataFlash and 3-wire EEPROMs
 - Serial Peripherals, such as ADCs, DACs, LCD Controllers, CAN Controllers and Sensors
 - External Co-processors
- Master or Slave Serial Peripheral Bus Interface
 - 8- to 16-bit Programmable Data Length Per Chip Select
 - Programmable Phase and Polarity Per Chip Select
 - Programmable Transfer Delays Between Consecutive Transfers and Between Clock and Data Per Chip Select
 - Programmable Delay Between Consecutive Transfers
 - Selectable Mode Fault Detection
- Connection to PDC Channel Capabilities Optimizes Data Transfers
 - One Channel for the Receiver, One Channel for the Transmitter
 - Next Buffer Support

28.2 Block Diagram

Figure 28-1. Block Diagram

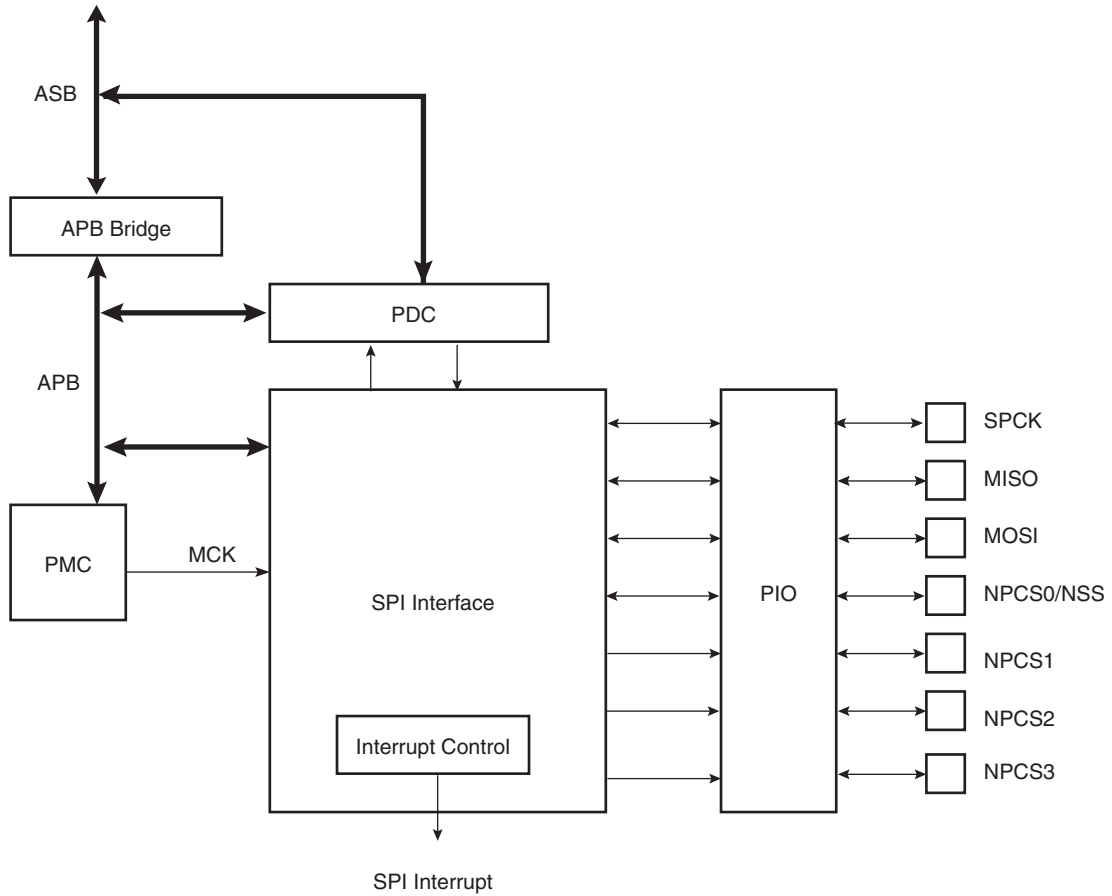

28.3 Application Block Diagram

Figure 28-2. Application Block Diagram: Single Master/Multiple Slave Implementation

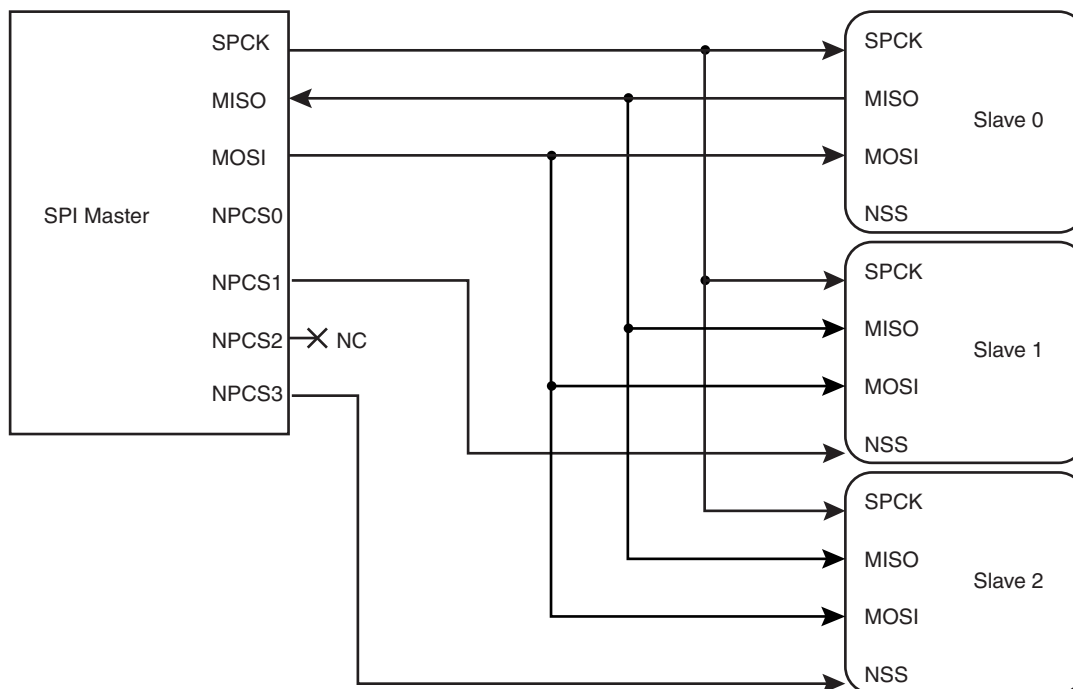

Table 28-1. Signal Description

Pin Name	Pin Description	Type	
		Master	Slave
MISO	Master In Slave Out	Input	Output
MOSI	Master Out Slave In	Output	Input
SPCK	Serial Clock	Output	Input
NPCS1-NPCS3	Peripheral Chip Selects	Output	Unused
NPCS0/NSS	Peripheral Chip Select/Slave Select	Output	Input

28.4 Product Dependencies

28.4.1 I/O Lines

The pins used for interfacing the compliant external devices may be multiplexed with PIO lines. The programmer must first program the PIO controllers to assign the SPI pins to their peripheral functions.

28.4.2 Power Management

The SPI may be clocked through the Power Management Controller (PMC), thus the programmer must first have to configure the PMC to enable the SPI clock.

28.4.3 Interrupt

The SPI interface has an interrupt line connected to the Advanced Interrupt Controller (AIC). Handling the SPI interrupt requires programming the AIC before configuring the SPI.

28.5 Functional Description

28.5.1 Master Mode Operations

When configured in Master Mode, the Serial Peripheral Interface controls data transfers to and from the slave(s) connected to the SPI bus. The SPI drives the chip select(s) to the slave(s) and the serial clock (SPCK). After enabling the SPI, a data transfer begins when the core writes to the SPI_TDR (Transmit Data Register).

Transmit and Receive buffers maintain the data flow at a constant rate with a reduced requirement for high-priority interrupt servicing. When new data is available in the SPI_TDR, the SPI continues to transfer data. If the SPI_RDR (Receive Data Register) has not been read before new data is received, the Overrun Error (OVRES) flag is set.

Note: As long as this flag is set, no data is loaded in the SPI_RDR. The user has to read the status register to clear it.

The programmable delay between the activation of the chip select and the start of the data transfer (DLYBS), as well as the delay between each data transfer (DLYBCT), can be programmed for each of the four external chip selects. All data transfer characteristics, including the two timing values, are programmed in registers SPI_CSR0 to SPI_CSR3 (Chip Select Registers).

In Master Mode, the peripheral selection can be defined in two different ways:

- Fixed Peripheral Select: SPI exchanges data with only one peripheral
- Variable Peripheral Select: Data can be exchanged with more than one peripheral

[Figure 28-7](#) and [Figure 28-8](#) show the operation of the SPI in Master Mode. For details concerning the flag and control bits in these diagrams, see the “[Serial Peripheral Interface \(SPI\) User Interface](#)” on [page 382](#) and the subsequent register descriptions.

28.5.1.1 Fixed Peripheral Select

This mode is used for transferring memory blocks without the extra overhead in the transmit data register to determine the peripheral.

Fixed Peripheral Select is activated by setting bit PS to zero in SPI_MR (Mode Register). The peripheral is defined by the PCS field in SPI_MR.

This option is only available when the SPI is programmed in Master Mode.

28.5.1.2 Variable Peripheral Select

Variable Peripheral Select is activated by setting bit PS to one. The PCS field in SPI_TDR is used to select the destination peripheral. The data transfer characteristics are changed when the selected peripheral changes, according to the associated chip select register.

The PCS field in the SPI_MR has no effect.

This option is only available when the SPI is programmed in Master Mode.

28.5.1.3 Chip Selects

The Chip Select lines are driven by the SPI only if it is programmed in Master Mode. These lines are used to select the destination peripheral. The PCSDEC field in SPI_MR (Mode Register) selects one to four peripherals (PCSDEC = 0) or up to 15 peripherals (PCSDEC = 1).

If Variable Peripheral Select is active, the chip select signals are defined for each transfer in the PCS field in SPI_TDR. Chip select signals can thus be defined independently for each transfer.

If Fixed Peripheral Select is active, Chip Select signals are defined for all transfers by the field PCS in SPI_MR. If a transfer with a new peripheral is necessary, the software must wait until the current transfer is completed, then change the value of PCS in SPI_MR before writing new data in SPI_TDR.

The value on the NPCS pins at the end of each transfer can be read in the SPI_RDR (Receive Data Register).

By default, all NPCS signals are high (equal to one) before and after each transfer.

28.5.1.4 Clock Generation and Transfer Delays

The SPI Baud rate clock is generated by dividing the Master Clock (MCK) or the Master Clock divided by 32 (if DIV32 is set in the Mode Register) by a value between 4 and 510. The divisor is defined in the SCBR field in each Chip Select Register. The transfer speed can thus be defined independently for each chip select signal.

Figure 28-3 shows a chip select transfer change and consecutive transfers on the same chip selects. Three delays can be programmed to modify the transfer waveforms:

- Delay between chip selects, programmable only once for all the chip selects by writing the field DLYBCS in the Mode Register. Allows insertion of a delay between release of one chip select and before assertion of a new one.
- Delay before SPCK, independently programmable for each chip select by writing the field DLYBS. Allows the start of SPCK to be delayed until after the chip select has been asserted.
- Delay between consecutive transfers, independently programmable for each chip select by writing the field DLYBCT. Allows insertion of a delay between two transfers occurring on the same chip select

These delays allow the SPI to be adapted to the interfaced peripherals and their speed and bus release time.

Figure 28-3. Programmable Delays

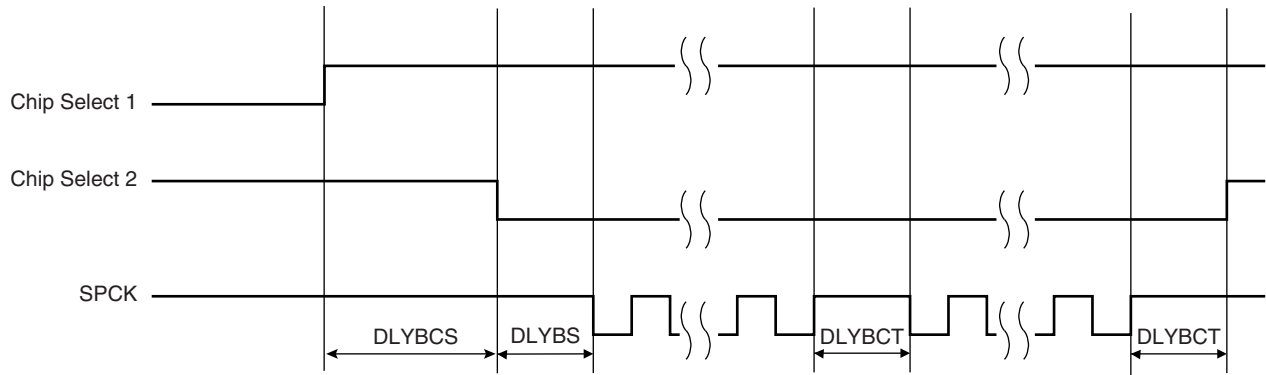

28.5.1.5 Mode Fault Detection

A mode fault is detected when the SPI is programmed in Master Mode and a low level is driven by an external master on the NPCS0/NSS signal.

When a mode fault is detected, the MODF bit in the SPI_SR is set until the SPI_SR is read and the SPI is disabled until re-enabled by bit SPIEN in the SPI_CR (Control Register).

By default, Mode Fault Detection is enabled. It is disabled by setting the MODFDIS bit in the SPI Mode Register.

28.5.1.6 Master Mode Flow Diagram

Figure 28-4. Master Mode Flow Diagram

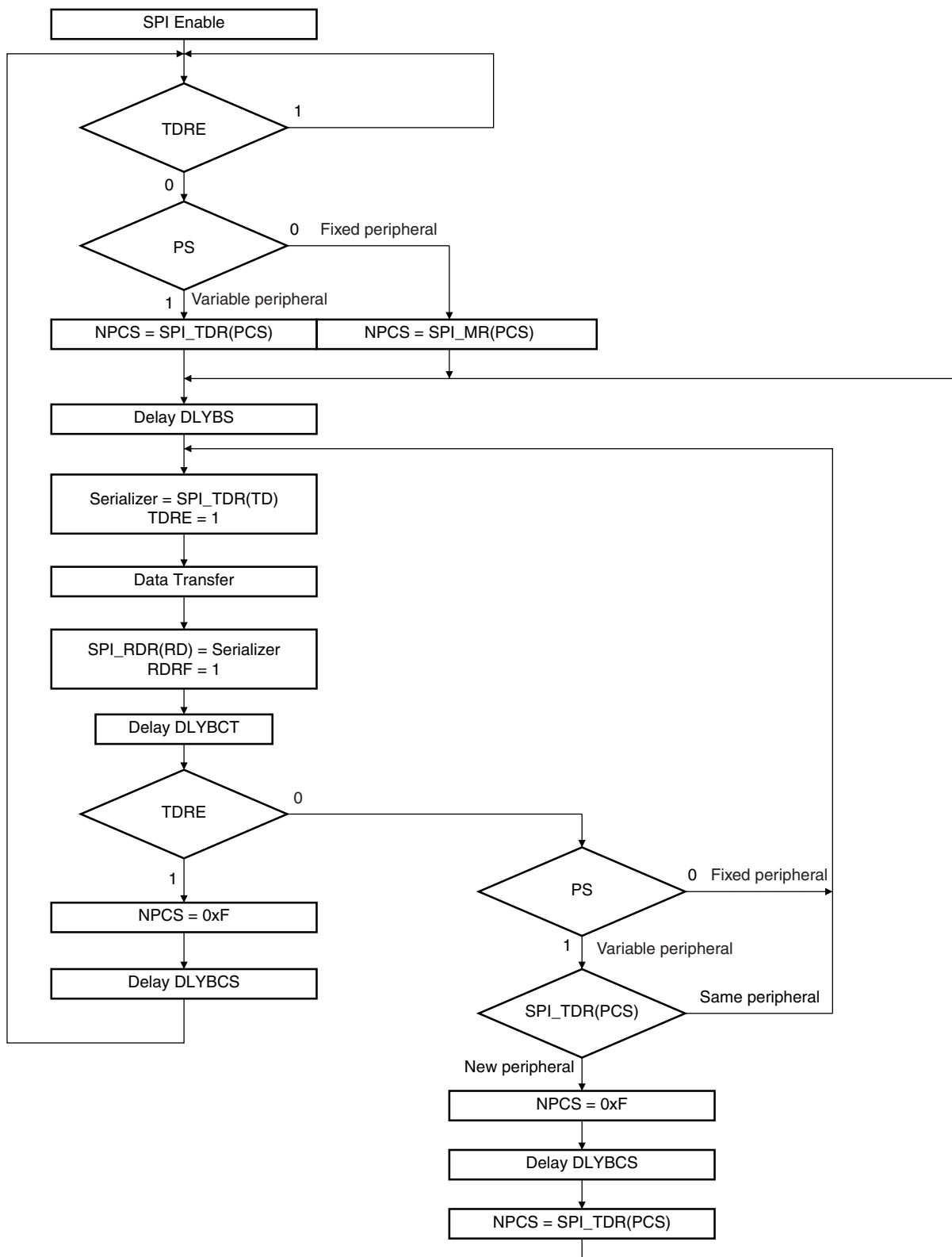

28.5.1.7 Master Mode Block Diagram

Figure 28-5. Master Mode Block Diagram

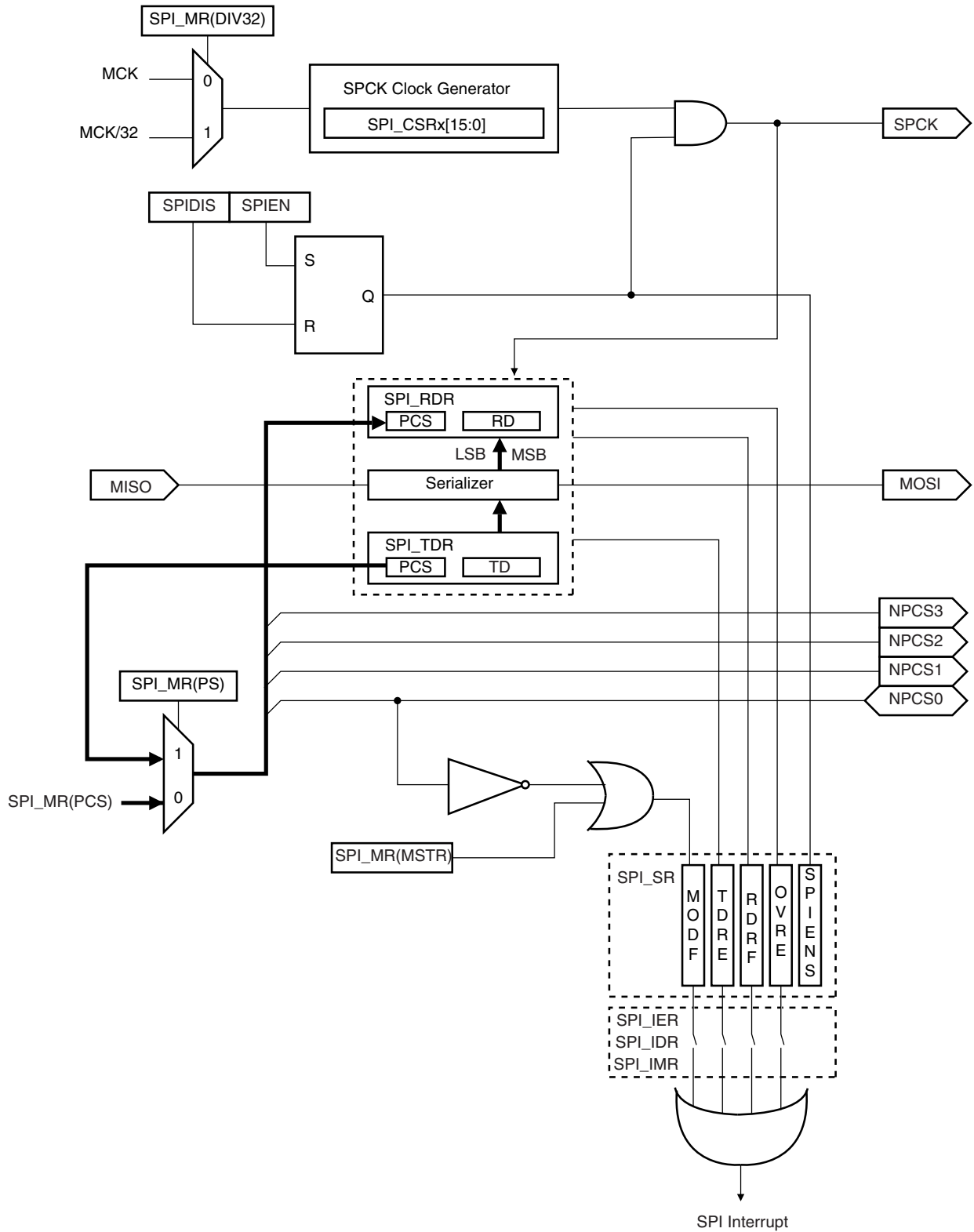

28.5.2 SPI Slave Mode

In Slave Mode, the SPI waits for NSS to go active low before receiving the serial clock from an external master.

In Slave Mode, CPOL, NCPHA and BITS fields of SPI_CSR0 are used to define the transfer characteristics. The other Chip Select Registers are not used in Slave Mode.

In Slave Mode, the low and high pulse durations of the input clock on SPCK must be longer than two Master Clock periods.

Figure 28-6. Slave Mode Block Diagram

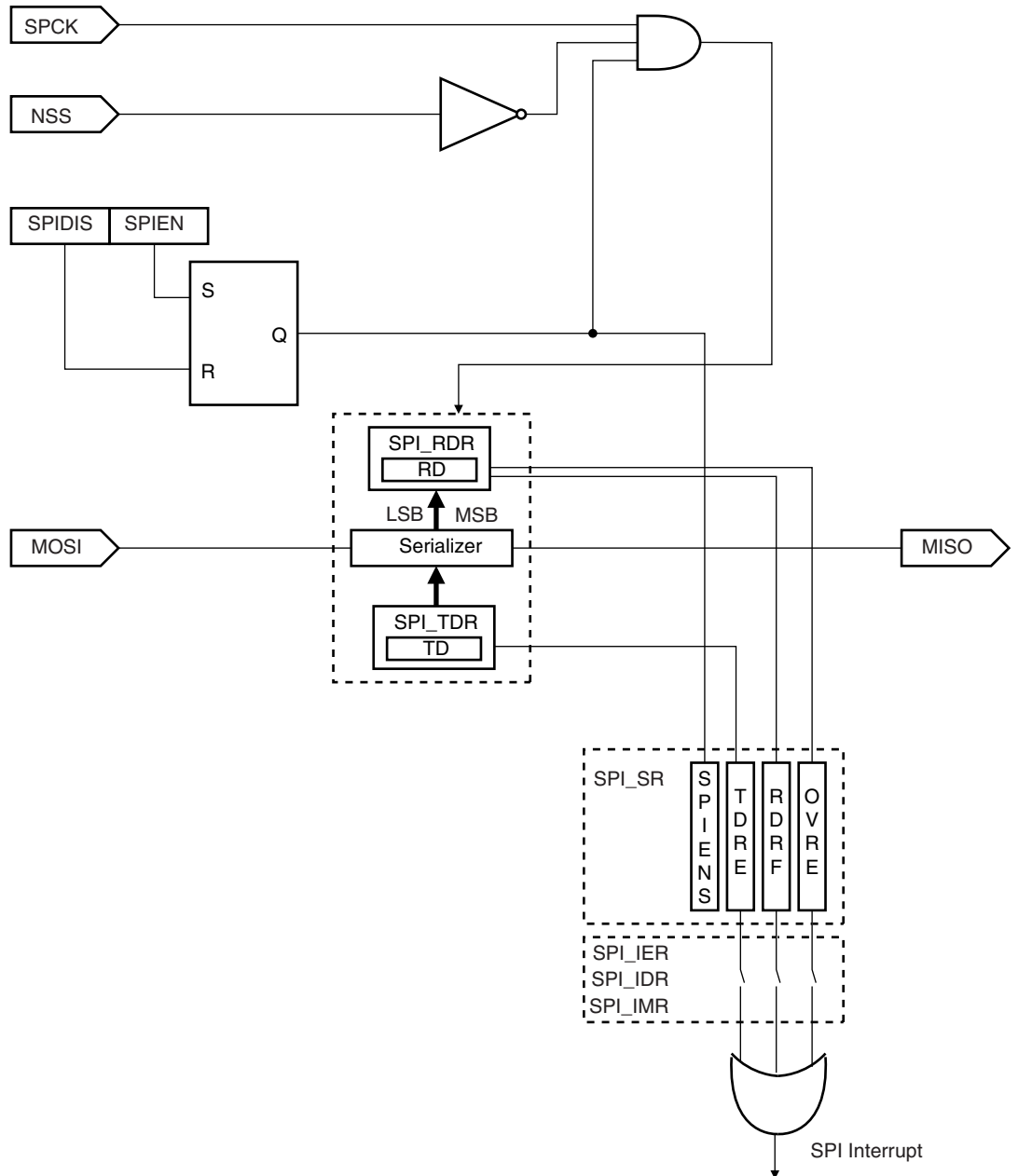

28.5.3 Data Transfer

Four modes are used for data transfers. These modes correspond to combinations of a pair of parameters called clock polarity (CPOL) and clock phase (NCPHA) that determine the edges of the clock signal on which the data are driven and sampled. Each of the two parameters has two possible states, resulting in four possible combinations that are incompatible with one another. Thus a master/slave pair must use the same parameter pair values to communicate. If multiple slaves are used and fixed in different configurations, the master must reconfigure itself each time it needs to communicate with a different slave.

Table 28-2 shows the four modes and corresponding parameter settings.

Table 28-2. SPI Bus Protocol Mode

SPI Mode	CPOL	NCPHA
0	0	1
1	0	0
2	1	1
3	1	0

Figure 28-7 and Figure 28-8 show examples of data transfers.

Figure 28-7. SPI Transfer Format (NCPHA = 1, 8 bits per transfer)

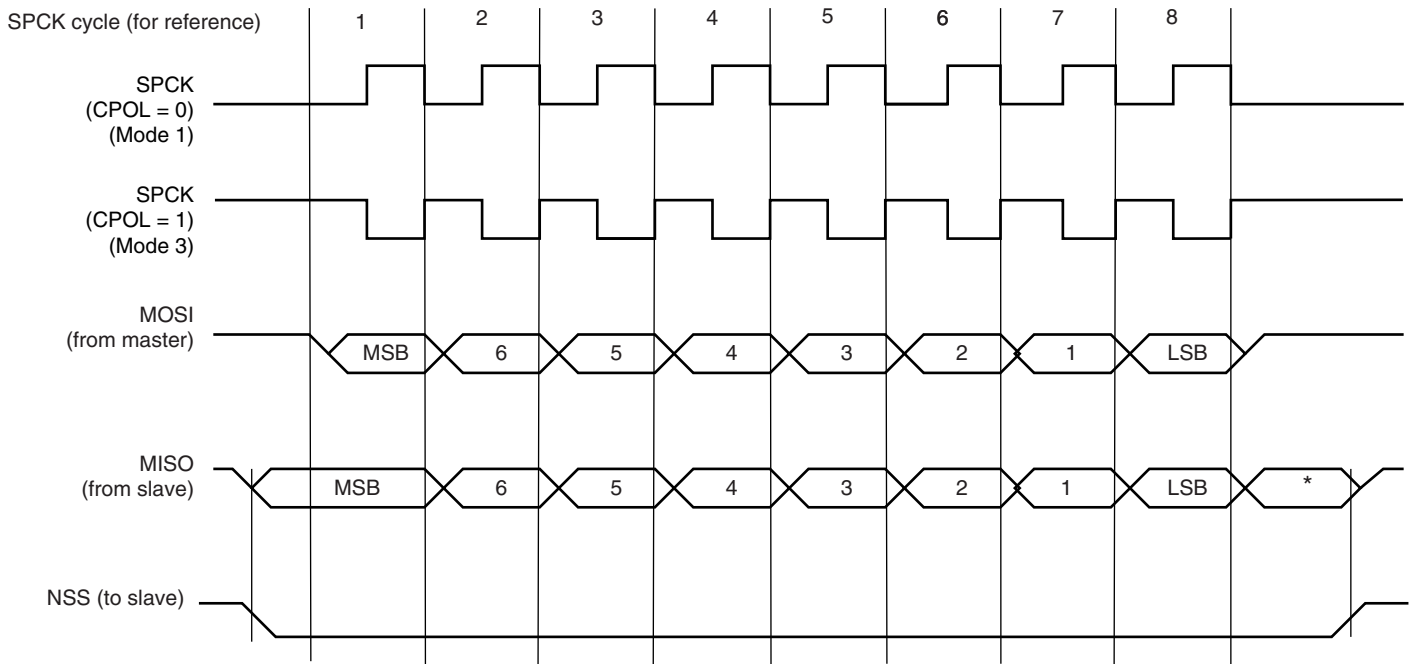

* Not defined, but normally MSB of previous character received.

Figure 28-8. SPI Transfer Format (NCPHA = 0, 8 bits per transfer)

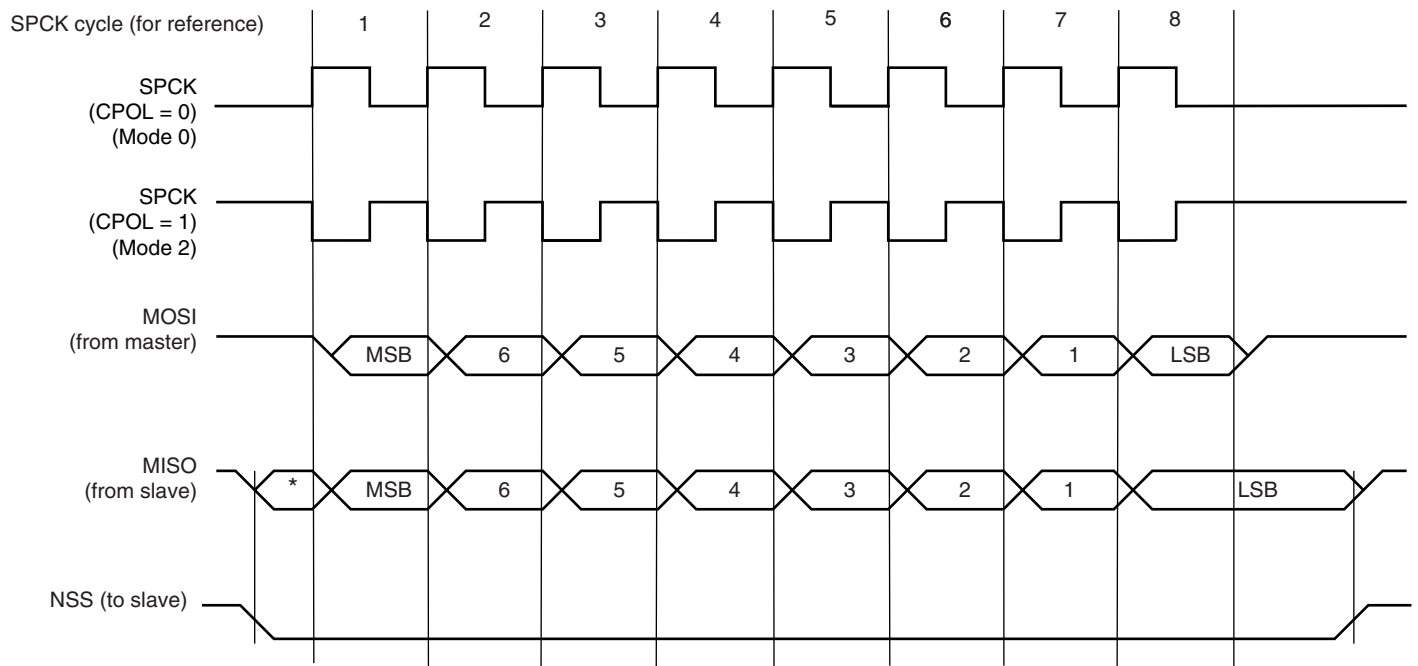

* Not defined but normally LSB of previous character transmitted.

28.6 Serial Peripheral Interface (SPI) User Interface

Table 28-3. SPI Register Mapping

Offset	Register	Register Name	Access	Reset
0x00	Control Register	SPI_CR	Write-only	---
0x04	Mode Register	SPI_MR	Read/Write	0x0
0x08	Receive Data Register	SPI_RDR	Read-only	0x0
0x0C	Transmit Data Register	SPI_TDR	Write-only	---
0x10	Status Register	SPI_SR	Read-only	0x000000F0
0x14	Interrupt Enable Register	SPI_IER	Write-only	---
0x18	Interrupt Disable Register	SPI_IDR	Write-only	---
0x1C	Interrupt Mask Register	SPI_IMR	Read-only	0x0
0x20 - 0x2C	Reserved			
0x30	Chip Select Register 0	SPI_CSR0	Read/Write	0x0
0x34	Chip Select Register 1	SPI_CSR1	Read/Write	0x0
0x38	Chip Select Register 2	SPI_CSR2	Read/Write	0x0
0x3C	Chip Select Register 3	SPI_CSR3	Read/Write	0x0
0x40 - 0xFF	Reserved			
0x100 - 0x124	Reserved for the PDC			

28.6.1 SPI Control Register

Name: SPI_CR

Access Type: Write-only

31	30	29	28	27	26	25	24
–	–	–	–	–	–	–	–
23	22	21	20	19	18	17	16
–	–	–	–	–	–	–	–
15	14	13	12	11	10	9	8
–	–	–	–	–	–	–	–
7	6	5	4	3	2	1	0
SWRST	–	–	–	–	–	SPIDIS	SPIEN

- **SPIEN: SPI Enable**

0 = No effect.

1 = Enables the SPI to transfer and receive data.

- **SPIDIS: SPI Disable**

0 = No effect.

1 = Disables the SPI.

All pins are set in input mode and no data is received or transmitted.

If a transfer is in progress, the transfer is finished before the SPI is disabled.

If both SPIEN and SPIDIS are equal to one when the control register is written, the SPI is disabled

- **SWRST: SPI Software Reset**

0 = No effect.

1 = Reset the SPI.

A software-triggered hardware reset of the SPI interface is performed.

28.6.2 SPI Mode Register

Name: SPI_MR

Access Type: Read/Write

31	30	29	28	27	26	25	24
DLYBCS							
23	22	21	20	19	18	17	16
–	–	–	–	PCS			
15	14	13	12	11	10	9	8
–	–	–	–	–	–	–	–
7	6	5	4	3	2	1	0
LLB	–	–	MODFDIS	DIV32	PCSDEC	PS	MSTR

- **MSTR: Master/Slave Mode**

0 = SPI is in Slave mode.

1 = SPI is in Master mode.

- **PS: Peripheral Select**

0 = Fixed Peripheral Select.

1 = Variable Peripheral Select.

- **PCSDEC: Chip Select Decode**

0 = The chip selects are directly connected to a peripheral device.

1 = The four chip select lines are connected to a 4- to 16-bit decoder.

When PCSDEC equals one, up to 16 Chip Select signals can be generated with the four lines using an external 4- to 16-bit decoder.

The Chip Select Registers define the characteristics of the 16 chip selects according to the following rules:

SPI_CSR0 defines peripheral chip select signals 0 to 3.

SPI_CSR1 defines peripheral chip select signals 4 to 7.

SPI_CSR2 defines peripheral chip select signals 8 to 11.

SPI_CSR3 defines peripheral chip select signals 12 to 15*.

**Note: The 16th state corresponds to a state in which all chip selects are inactive. This allows a different clock configuration to be defined by each chip select register.*

- **DIV32: Clock Selection**

0 = The SPI operates at MCK.

1 = The SPI operates at MCK/32.

- **MODFDIS: Mode Fault Detection**

0 = Mode fault detection is enabled.

1 = Mode fault detection is disabled.

- **LLB: Local Loopback Enable**

0 = Local loopback path disabled

1 = Local loopback path enabled

LLB controls the local loopback on the data serializer for testing in Master Mode only.

- **PCS: Peripheral Chip Select**

This field is only used if Fixed Peripheral Select is active (PS = 0).

If PCSDEC = 0:

PCS = xxx0 NPCS[3:0] = 1110

PCS = xx01 NPCS[3:0] = 1101

PCS = x011 NPCS[3:0] = 1011

PCS = 0111 NPCS[3:0] = 0111

PCS = 1111 forbidden (no peripheral is selected)

(x = don't care)

If PCSDEC = 1:

NPCS[3:0] output signals = PCS

- **DLYBCS: Delay Between Chip Selects**

This field defines the delay from NPCS inactive to the activation of another NPCS. The DLYBCS time guarantees non-overlapping chip selects and solves bus contentions in case of peripherals having long data float times.

If DLYBCS is less than or equal to six, six MCK periods (or 192 MCK periods if DIV32 is set) will be inserted by default.

Otherwise, the following equation determines the delay:

If DIV32 is 0:

$$\text{Delay Between Chip Selects} = \text{DLYBCS} / \text{MCK}$$

If DIV32 is 1:

$$\text{Delay Between Chip Selects} = \text{DLYBCS} \times 32 / \text{MCK}$$

28.6.3 SPI Receive Data Register

Name: SPI_RDR

Access Type: Read-only

31	30	29	28	27	26	25	24
–	–	–	–	–	–	–	–
23	22	21	20	19	18	17	16
–	–	–	–	PCS			
15	14	13	12	11	10	9	8
RD							
7	6	5	4	3	2	1	0
RD							

- **RD: Receive Data**

Data received by the SPI Interface is stored in this register right-justified. Unused bits read zero.

- **PCS: Peripheral Chip Select**

In Master Mode only, these bits indicate the value on the NPCS pins at the end of a transfer. Otherwise, these bits read zero.

28.6.4 SPI Transmit Data Register

Name: SPI_TDR

Access Type: Write-only

31	30	29	28	27	26	25	24
–	–	–	–	–	–	–	–
23	22	21	20	19	18	17	16
–	–	–	–	PCS			
15	14	13	12	11	10	9	8
TD							
7	6	5	4	3	2	1	0
TD							

- **TD: Transmit Data**

Data to be transmitted by the SPI Interface is stored in this register. Information to be transmitted must be written to the transmit data register in a right-justified format.

PCS: Peripheral Chip Select

This field is only used if Variable Peripheral Select is active (PS = 1).

If PCSDEC = 0:

PCS = xxx0 NPCS[3:0] = 1110
 PCS = xx01 NPCS[3:0] = 1101
 PCS = x011 NPCS[3:0] = 1011
 PCS = 0111 NPCS[3:0] = 0111
 PCS = 1111 forbidden (no peripheral is selected)

(x = don't care)

If PCSDEC = 1:

NPCS[3:0] output signals = PCS

28.6.5 SPI Status Register

Name: SPI_SR

Access Type: Read-only

31	30	29	28	27	26	25	24
–	–	–	–	–	–	–	–
23	22	21	20	19	18	17	16
–	–	–	–	–	–	–	SPIENS
15	14	13	12	11	10	9	8
–	–	–	–	–	–	–	–
7	6	5	4	3	2	1	0
TXBUFE	RXBUFF	ENDTX	ENDRX	OVRES	MODF	TDRE	RDRF

- **RDRF: Receive Data Register Full**

0 = No data has been received since the last read of SPI_RDR

1 = Data has been received and the received data has been transferred from the serializer to SPI_RDR since the last read of SPI_RDR.

- **TDRE: Transmit Data Register Empty**

0 = Data has been written to SPI_TDR and not yet transferred to the serializer.

1 = The last data written in the Transmit Data Register has been transferred to the serializer.

TDRE equals zero when the SPI is disabled or at reset. The SPI enable command sets this bit to one.

- **MODF: Mode Fault Error**

0 = No Mode Fault has been detected since the last read of SPI_SR.

1 = A Mode Fault occurred since the last read of the SPI_SR.

- **OVRES: Overrun Error Status**

0 = No overrun has been detected since the last read of SPI_SR.

1 = An overrun has occurred since the last read of SPI_SR.

An overrun occurs when SPI_RDR is loaded at least twice from the serializer since the last read of the SPI_RDR.

- **ENDRX: End of RX buffer**

0 = The Receive Counter Register has not reached 0 since the last write in SPI_RCR or SPI_RNCR.

1 = The Receive Counter Register has reached 0 since the last write in SPI_RCR or SPI_RNCR.

- **ENDTX: End of TX buffer**

0 = The Transmit Counter Register has not reached 0 since the last write in SPI_TCR or SPI_TNCR.

1 = The Transmit Counter Register has reached 0 since the last write in SPI_TCR or SPI_TNCR.

- **RXBUFF: RX Buffer Full**

0 = SPI_RCR or SPI_RNCR have a value other than 0.

1 = Both SPI_RCR and SPI_RNCR have a value of 0.

- **TXBUFE: TX Buffer Empty**

0 = SPI_TCR or SPI_TNCR have a value other than 0.

1 = Both SPI_TCR and SPI_TNCR have a value of 0.

- **SPIENS: SPI Enable Status**

0 = SPI is disabled.

1 = SPI is enabled.

28.6.6 SPI Interrupt Enable Register

Name: SPI_IER

Access Type: Write-only

31	30	29	28	27	26	25	24
–	–	–	–	–	–	–	–
23	22	21	20	19	18	17	16
–	–	–	–	–	–	–	–
15	14	13	12	11	10	9	8
–	–	–	–	–	–	–	–
7	6	5	4	3	2	1	0
TXBUFE	RXBUFF	ENDTX	ENDRX	OVRES	MODF	TDRE	RDRF

- **RDRF: Receive Data Register Full Interrupt Enable**
- **TDRE: SPI Transmit Data Register Empty Interrupt Enable**
- **MODF: Mode Fault Error Interrupt Enable**
- **OVRES: Overrun Error Interrupt Enable**

- **ENDRX: End of Receive Buffer Interrupt Enable**
- **ENDTX: End of Transmit Buffer Interrupt Enable**

- **RXBUFF: Receive Buffer Full Interrupt Enable**

- **TXBUFE: Transmit Buffer Empty Interrupt Enable**

0 = No effect.

1 = Enables the corresponding interrupt.

28.6.7 SPI Interrupt Disable Register

Name: SPI_IDR

Access Type: Write-only

31	30	29	28	27	26	25	24
–	–	–	–	–	–	–	–
23	22	21	20	19	18	17	16
–	–	–	–	–	–	–	–
15	14	13	12	11	10	9	8
–	–	–	–	–	–	–	–
7	6	5	4	3	2	1	0
TXBUFE	RXBUFF	ENDTX	ENDRX	OVRES	MODF	TDRE	RDRF

- **RDRF: Receive Data Register Full Interrupt Disable**
- **TDRE: SPI Transmit Data Register Empty Interrupt Disable**
- **MODF: Mode Fault Error Interrupt Disable**
- **OVRES: Overrun Error Interrupt Disable**

- **ENDRX: End of Receive Buffer Interrupt Disable**
- **ENDTX: End of Transmit Buffer Interrupt Disable**

- **RXBUFF: Receive Buffer Full Interrupt Disable**

- **TXBUFE: Transmit Buffer Empty Interrupt Disable**

0 = No effect.

1 = Disables the corresponding interrupt.

28.6.8 SPI Interrupt Mask Register

Name: SPI_IMR

Access Type: Read-only

31	30	29	28	27	26	25	24
–	–	–	–	–	–	–	–
23	22	21	20	19	18	17	16
–	–	–	–	–	–	–	–
15	14	13	12	11	10	9	8
–	–	–	–	–	–	–	–
7	6	5	4	3	2	1	0
TXBUFE	RXBUFF	ENDTX	ENDRX	OVRES	MODF	TDRE	RDRF

- **RDRF: Receive Data Register Full Interrupt Mask**
- **TDRE: SPI Transmit Data Register Empty Interrupt Mask**
- **MODF: Mode Fault Error Interrupt Mask**
- **OVRES: Overrun Error Interrupt Mask**

- **ENDRX: End of Receive Buffer Interrupt Mask**
- **ENDTX: End of Transmit Buffer Interrupt Mask**

- **RXBUFF: Receive Buffer Full Interrupt Mask**

- **TXBUFE: Transmit Buffer Empty Interrupt Mask**

0 = The corresponding interrupt is not enabled.

1 = The corresponding interrupt is enabled.

28.6.9 SPI Chip Select Register

Name: SPI_CSR0... SPI_CSR3

Access Type: Read/Write

31	30	29	28	27	26	25	24
DLYBCT							
23	22	21	20	19	18	17	16
DLYBS							
15	14	13	12	11	10	9	8
SCBR							
7	6	5	4	3	2	1	0
BITS				–	–	NCPHA	CPOL

- **CPOL: Clock Polarity**

0 = The inactive state value of SPCK is logic level zero.

1 = The inactive state value of SPCK is logic level one.

CPOL is used to determine the inactive state value of the serial clock (SPCK). It is used with NCPHA to produce the required clock/data relationship between master and slave devices.

- **NCPHA: Clock Phase**

0 = Data is changed on the leading edge of SPCK and captured on the following edge of SPCK.

1 = Data is captured on the leading edge of SPCK and changed on the following edge of SPCK.

NCPHA determines which edge of SPCK causes data to change and which edge causes data to be captured. NCPHA is used with CPOL to produce the required clock/data relationship between master and slave devices.

- **BITS: Bits Per Transfer**

The BITS field determines the number of data bits transferred. Reserved values should not be used.

BITS[3:0]	Bits Per Transfer
0000	8
0001	9
0010	10
0011	11
0100	12
0101	13
0110	14
0111	15
1000	16
1001	Reserved
1010	Reserved
1011	Reserved
1100	Reserved
1101	Reserved
1110	Reserved
1111	Reserved

- **SCBR: Serial Clock Baud Rate**

In Master Mode, the SPI Interface uses a modulus counter to derive the SPCK baud rate from the Master Clock MCK. The Baud rate is selected by writing a value from 2 to 255 in the field SCBR. The following equation determines the SPCK baud rate:

If DIV32 is 0:

$$\text{SPCK Baudrate} = \text{MCK} / (2 \times \text{SCBR})$$

If DIV32 is 1:

$$\text{SPCK Baudrate} = \text{MCK} / (64 \times \text{SCBR})$$

Giving SCBR a value of zero or one disables the baud rate generator. SPCK is disabled and assumes its inactive state value. No serial transfers may occur. At reset, baud rate is disabled.

- **DLYBS: Delay Before SPCK**

This field defines the delay from NPCS valid to the first valid SPCK transition.

When DLYBS equals zero, the NPCS valid to SPCK transition is 1/2 the SPCK clock period.

Otherwise, the following equations determine the delay:

If DIV32 is 0:

$$\text{Delay Before SPCK} = \text{DLYBS} / \text{MCK}$$

If DIV32 is 1:

$$\text{Delay Before SPCK} = 32 \times \text{DLYBS} / \text{MCK}$$

- **DLYBCT: Delay Between Consecutive Transfers**

This field defines the delay between two consecutive transfers with the same peripheral without removing the chip select. The delay is always inserted after each transfer and before removing the chip select if needed.

When DLYBCT equals zero, a minimum delay of four MCK cycles are inserted (or 128 MCK cycles when DIV32 is set) between two consecutive characters.

Otherwise, the following equation determines the delay:

If DIV32 is 0:

$$\text{Delay Between Consecutive Transfers} = 32 \times \text{DLYBCT} / \text{MCK}$$

If DIV32 is 1:

$$\text{Delay Between Consecutive Transfers} = 1024 \times \text{DLYBCT} / \text{MCK}$$

29. Two-wire Interface (TWI)

29.1 Overview

The Two-wire Interface (TWI) interconnects components on a unique two-wire bus, made up of one clock line and one data line with speeds of up to 400 Kbits per second, based on a byte-oriented transfer format. It can be used with any Atmel two-wire bus serial EEPROM. The TWI is programmable as a master with sequential or single-byte access.

A configurable baud rate generator permits the output data rate to be adapted to a wide range of core clock frequencies.

The main features of the TWI are:

- Compatibility with standard two-wire serial memory
- One, two or three bytes for slave address
- Sequential Read/Write operations

29.2 Block Diagram

Figure 29-1. Block Diagram

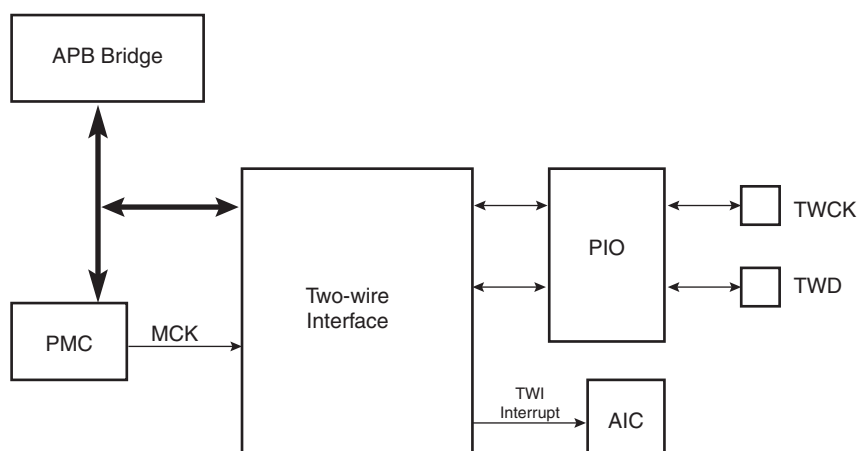

29.3 Application Block Diagram

Figure 29-2. Application Block Diagram

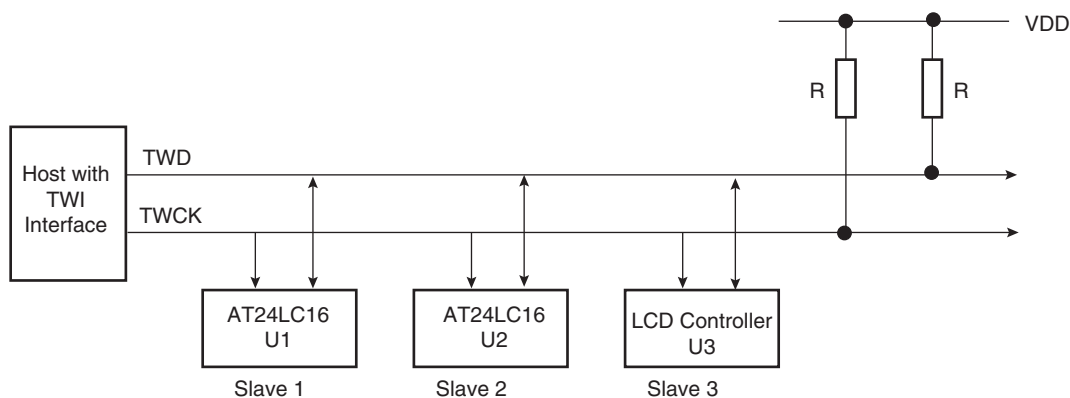

Table 29-1. I/O Lines Description

Pin Name	Pin Description	Type
TWD	Two-wire Serial Data	Input/Output
TWCK	Two-wire Serial Clock	Input/Output

29.4 Product Dependencies

29.4.1 I/O Lines

Both TWD and TWCK are bi-directional lines, connected to a positive supply voltage via a current source or pull-up resistor (see [Figure 29-2 on page 395](#)). When the bus is free, both lines are high. The output stages of devices connected to the bus must have an open-drain or open-collector to perform the wired-AND function.

TWD and TWCK pins may be multiplexed with PIO lines. To enable the TWI, the programmer must perform the following steps:

- Program the PIO controller to:
 - Dedicate TWD and TWCK as peripheral lines.
 - Define TWD and TWCK as open-drain.

29.4.2 Power Management

- Enable the peripheral clock.

The TWI interface may be clocked through the Power Management Controller (PMC), thus the programmer must first configure the PMC to enable the TWI clock.

29.4.3 Interrupt

The TWI interface has an interrupt line connected to the Advanced Interrupt Controller (AIC). In order to handle interrupts, the AIC must be programmed before configuring the TWI.

29.5 Functional Description

29.5.1 Transfer Format

The data put on the TWD line must be eight bits long. Data is transferred MSB first; each byte must be followed by an acknowledgement. The number of bytes per transfer is unlimited (see [Figure 29-4 on page 397](#)).

Each transfer begins with a START condition and terminates with a STOP condition (see [Figure 29-3 on page 397](#)).

- A high-to-low transition on the TWD line while TWCK is high defines the START condition.
- A low-to-high transition on the TWD line while TWCK is high defines a STOP condition.

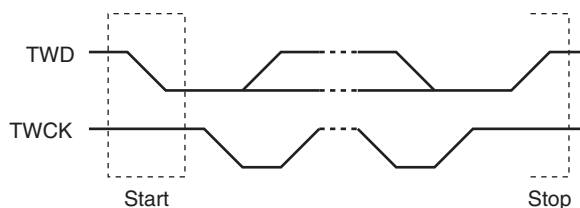
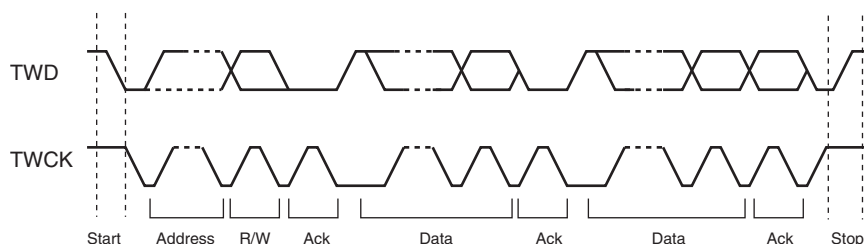
Figure 29-3. START and STOP Conditions**Figure 29-4.** Transfer Format

29.5.2 Modes of Operation

The TWI has two modes of operations:

- Master transmitter mode
- Master receiver mode

The TWI Control Register (TWI_CR) allows configuration of the interface in Master Mode. In this mode, it generates the clock according to the value programmed in the Clock Waveform Generator Register (TWI_CWGR). This register defines the TWCK signal completely, enabling the interface to be adapted to a wide range of clocks.

29.5.3 Transmitting Data

After the master initiates a Start condition, it sends a 7-bit slave address, configured in the Master Mode register (DADR in TWI_MMR), to notify the slave device. The bit following the slave address indicates the transfer direction (write or read). If this bit is 0, it indicates a write operation (transmit operation). If the bit is 1, it indicates a request for data read (receive operation).

The TWI transfers require the slave to acknowledge each received byte. During the acknowledge clock pulse, the master releases the data line (HIGH), enabling the slave to pull it down in order to generate the acknowledge. The master polls the data line during this clock pulse and sets the **NAK** bit in the status register if the slave does not acknowledge the byte. As with the other status bits, an interrupt can be generated if enabled in the interrupt enable register (TWI_IER). After writing in the transmit-holding register (TWI_THR), setting the START bit in the control register starts the transmission. The data is shifted in the internal shifter and when an acknowledge is detected, the TXRDY bit is set until a new write in the TWI_THR (see [Figure 29-6 on page 398](#)). The master generates a stop condition to end the transfer.

The read sequence begins by setting the START bit. When the RXRDY bit is set in the status register, a character has been received in the receive-holding register (TWI_RHR). The RXRDY bit is reset when reading the TWI_RHR.

The TWI interface performs various transfer formats (7-bit slave address, 10-bit slave address). The three internal address bytes are configurable through the Master Mode register (TWI_MMR). If the slave device supports only a 7-bit address, the **IADRSZ** must be set to 0. For

slave address higher than seven bits, the user must configure the address size (**IADRSZ**) and set the other slave address bits in the internal address register (**TWI_IADR**).

Figure 29-5. Master Write with One, Two or Three Bytes Internal Address and One Data Byte

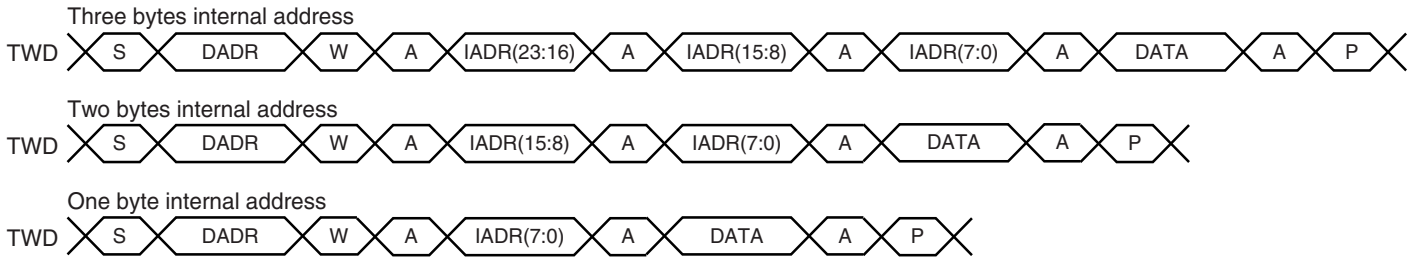

Figure 29-6. Master Write with One Byte Internal Address and Multiple Data Bytes

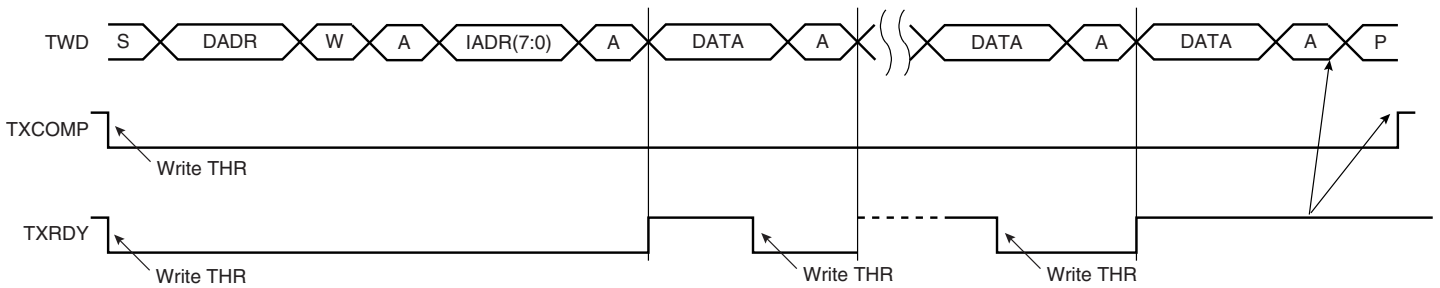

Figure 29-7. Master Read with One, Two or Three Bytes Internal Address and One Data Byte

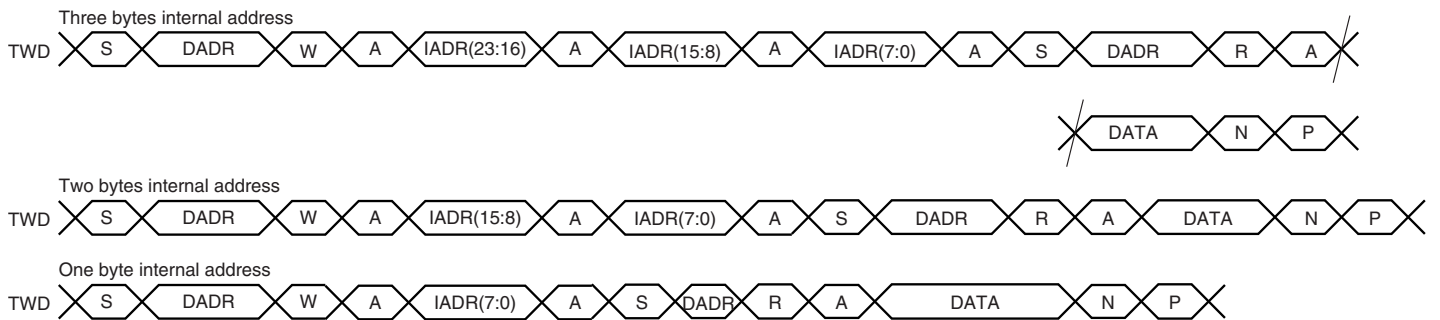
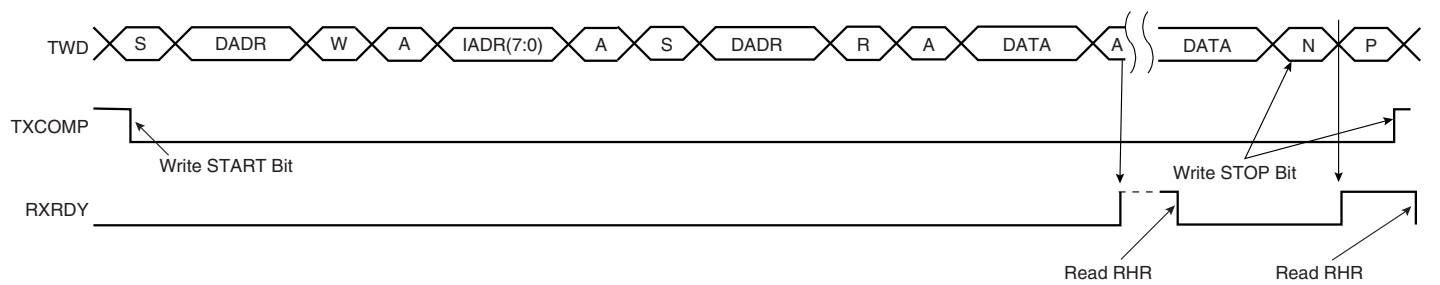

Figure 29-8. Master Read with One Byte Internal Address and Multiple Data Bytes



• S = Start

- P = Stop
- W = Write
- R = Read
- A = Acknowledge
- N = Not Acknowledge
- DADR= Device Address
- IADR = Internal Address

Figure 29-9 shows a byte write to an Atmel AT24LC512 EEPROM. This demonstrates the use of internal addresses to access the device.

Figure 29-9. Internal Address Usage

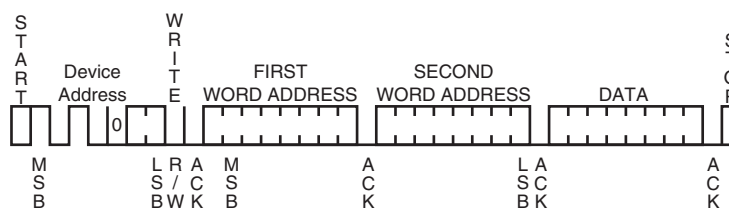

29.5.4 Read/Write Flowcharts

The following flowcharts shown in Figure 29-10 on page 400 and in Figure 29-11 on page 401 give examples for read and write operations in Master Mode. A polling or interrupt method can be used to check the status bits. The interrupt method requires that the interrupt enable register (TWI_IER) be configured first.

Figure 29-10. TWI Write in Master Mode

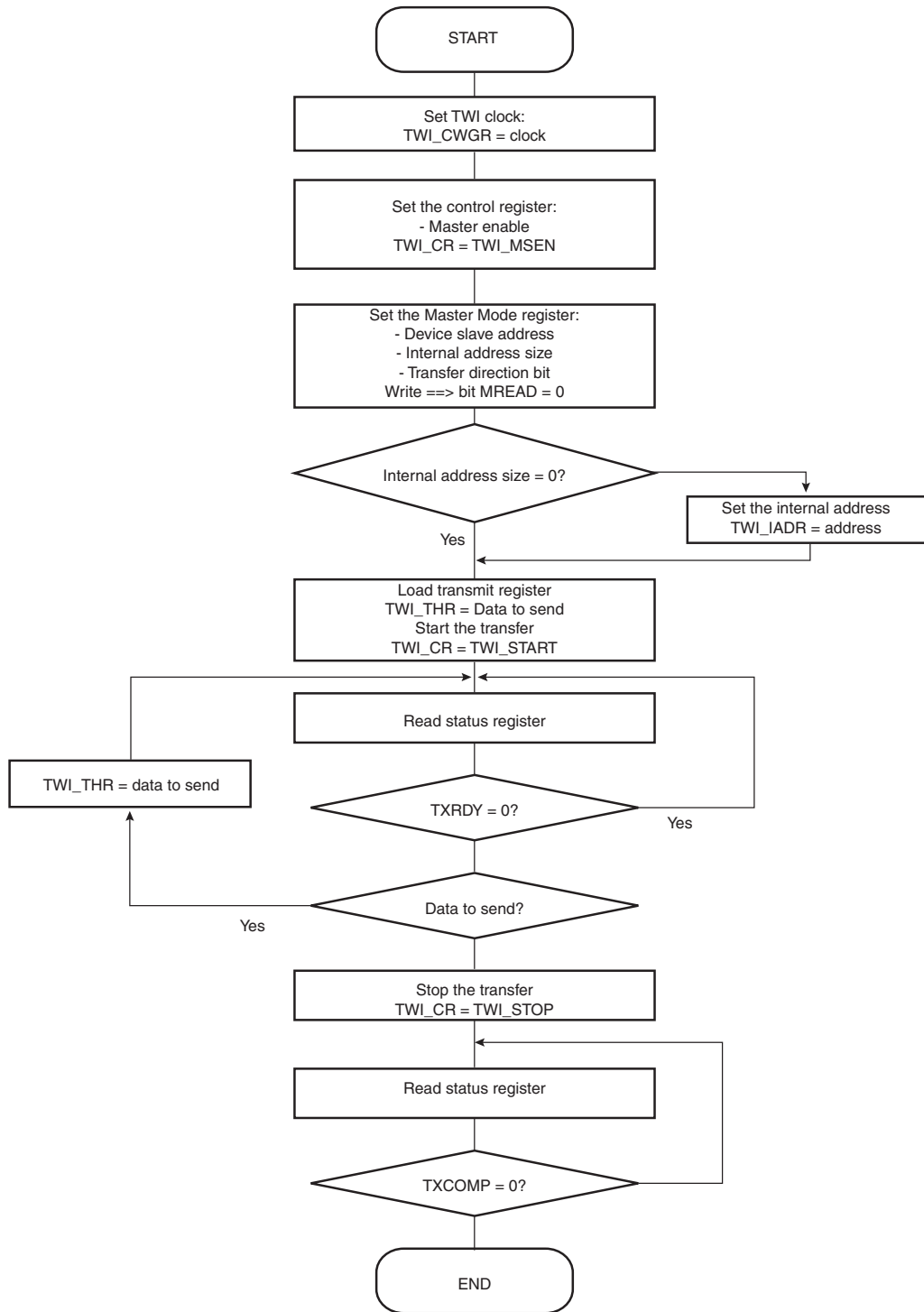
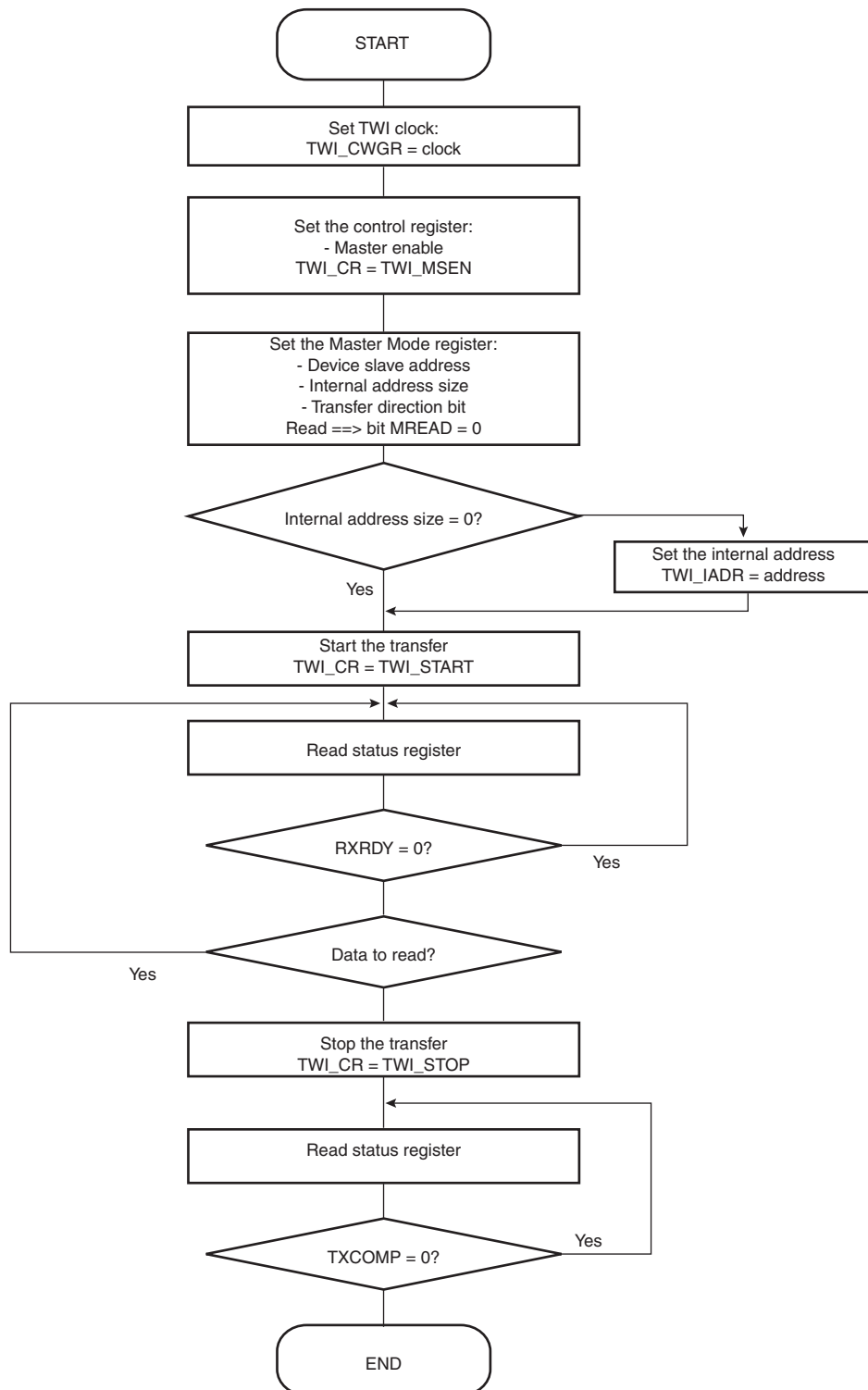

Figure 29-11. TWI Read in Master Mode



29.6 Two-wire Interface (TWI) User Interface

Table 29-2. TWI Register Mapping

Offset	Register	Name	Access	Reset Value
0x0000	Control Register	TWI_CR	Write-only	N/A
0x0004	Master Mode Register	TWI_MMR	Read/Write	0x0000
0x0008	Reserved			
0x000C	Internal Address Register	TWI_IADR	Read/Write	0x0000
0x0010	Clock Waveform Generator Register	TWI_CWGR	Read/Write	0x0000
0x0020	Status Register	TWI_SR	Read-only	0x0008
0x0024	Interrupt Enable Register	TWI_IER	Write-only	N/A
0x0028	Interrupt Disable Register	TWI_IDR	Write-only	N/A
0x002C	Interrupt Mask Register	TWI_IMR	Read-only	0x0000
0x0030	Receive Holding Register	TWI_RHR	Read-only	0x0000
0x0034	Transmit Holding Register	TWI_THR	Read/Write	0x0000

29.6.1 TWI Control Register

Register Name: TWI_CR

Access Type: Write-only

31	30	29	28	27	26	25	24
–	–	–	–	–	–	–	–
23	22	21	20	19	18	17	16
–	–	–	–	–	–	–	–
15	14	13	12	11	10	9	8
–	–	–	–	–	–	–	–
7	6	5	4	3	2	1	0
SWRST	–	–	–	MSDIS	MSEN	STOP	START

- **START: Send a START Condition**

0 = No effect.

1 = A frame beginning with a START bit is transmitted according to the features defined in the mode register.

This action is necessary when the TWI peripheral wants to read data from a slave. When configured in Master Mode with a write operation, a frame is sent with the mode register as soon as the user writes a character in the holding register.

- **STOP: Send a STOP Condition**

0 = No effect.

1 = STOP Condition is sent just after completing the current byte transmission in master read or write mode.

In single data byte master read or write, the START and STOP must both be set.

In multiple data bytes master read or write, the STOP must be set before ACK/NACK bit transmission.

In master read mode, if a NACK bit is received, the STOP is automatically performed.

In multiple data write operation, when both THR and shift register are empty, a STOP condition is automatically sent.

- **MSEN: TWI Master Transfer Enabled**

0 = No effect.

1 = If MSDIS = 0, the master data transfer is enabled.

- **MSDIS: TWI Master Transfer Disabled**

0 = No effect.

1 = The master data transfer is disabled, all pending data is transmitted. The shifter and holding characters (if it contains data) are transmitted in case of write operation. In read operation, the character being transferred must be completely received before disabling.

- **SWRST: Software Reset**

0 = No effect.

1 = Equivalent to a system reset.

29.6.2 TWI Master Mode Register

Register Name: TWI_MMR

Address Type: Read/Write

31	30	29	28	27	26	25	24
–	–	–	–	–	–	–	–
23	22	21	20	19	18	17	16
–	DADR						
15	14	13	12	11	10	9	8
–	–	–	MREAD	–	–	IADRSZ	
7	6	5	4	3	2	1	0
–	–	–	–	–	–	–	–

- **IADRSZ: Internal Device Address Size**

IADRSZ[9:8]		
0	0	No internal device address (Byte command protocol)
0	1	One-byte internal device address
1	0	Two-byte internal device address
1	1	Three-byte internal device address

- **MREAD: Master Read Direction**

0 = Master write direction.

1 = Master read direction.

- **DADR: Device Address**

The device address is used in Master Mode to access slave devices in read or write mode.

29.6.3 TWI Internal Address Register

Register Name: TWI_IADR

Access Type: Read/Write

31	30	29	28	27	26	25	24
–	–	–	–	–	–	–	–
23	22	21	20	19	18	17	16
IADR							
15	14	13	12	11	10	9	8
IADR							
7	6	5	4	3	2	1	0
IADR							

- **IADR: Internal Address**

0, 1, 2 or 3 bytes depending on IADRSZ. Low significant byte address in 10-bit mode addresses.

29.6.4 TWI Clock Waveform Generator Register

Register Name: TWI_CWGR

Access Type: Read/Write

31	30	29	28	27	26	25	24
–	–	–	–	–	–	–	–
23	22	21	20	19	18	17	16
–	–	–	–	–	CKDIV		
15	14	13	12	11	10	9	8
CHDIV							
7	6	5	4	3	2	1	0
CLDIV							

- **CLDIV: Clock Low Divider**

The TWCK low period is defined as follows:

$$T_{low} = ((CLDIV \times 2^{CKDIV}) + 3) \times T_{MCK}$$

- **CHDIV: Clock High Divider**

The TWCK high period is defined as follows:

$$T_{high} = ((CHDIV \times 2^{CKDIV}) + 3) \times T_{MCK}$$

- **CKDIV: Clock Divider**

The CKDIV is used to increase both TWCK high and low periods.

29.6.5 TWI Status Register

Register Name: TWI_SR

Access Type: Read-only

31	30	29	28	27	26	25	24
–	–	–	–	–	–	–	–
23	22	21	20	19	18	17	16
–	–	–	–	–	–	–	–
15	14	13	12	11	10	9	8
–	–	–	–	–	–	–	NACK
7	6	5	4	3	2	1	0
UNRE	OVRE	–	–	–	TXRDY	RXRDY	TXCOMP

- **TXCOMP: Transmission Completed**

0 = In master, during the length of the current frame. In slave, from START received to STOP received.

1 = When both holding and shifter registers are empty and STOP condition has been sent (in Master) or when MSEN is set (enable TWI).

- **RXRDY: Receive Holding Register Ready**

0 = No character has been received since the last TWI_RHR read operation.

1 = A byte has been received in the TWI_RHR since the last read.

- **TXRDY: Transmit Holding Register Ready**

0 = The transmit holding register has not been transferred into shift register. Set to 0 when writing into TWI_THR register.

1 = As soon as data byte is transferred from TWI_THR to internal shifter or if a NACK error is detected, TXRDY is set at the same time as TXCOMP and NACK. TXRDY is also set when MSEN is set (enable TWI).

- **OVRE: Overrun Error**

0 = TWI_RHR has not been loaded while RXRDY was set

1 = TWI_RHR has been loaded while RXRDY was set. Reset by read in TWI_SR when TXCOMP is set.

- **UNRE: Underrun Error**

0 = No underrun error

1 = No valid data in TWI_THR (TXRDY set) while trying to load the data shifter. This action automatically generated a STOP bit in Master Mode. Reset by read in TWI_SR when TXCOMP is set.

- **NACK: Not Acknowledged**

0 = Each data byte has been correctly received by the far-end side TWI slave component.

1 = A data byte has not been acknowledged by the slave component. Set at the same time as TXCOMP. Reset after read.

29.6.6 TWI Interrupt Enable Register

Register Name: TWI_IER

Access Type: Write-only

31	30	29	28	27	26	25	24
–	–	–	–	–	–	–	–
23	22	21	20	19	18	17	16
–	–	–	–	–	–	–	–
15	14	13	12	11	10	9	8
–	–	–	–	–	–	–	NACK
7	6	5	4	3	2	1	0
UNRE	OVRE	–	–	–	TXRDY	RXRDY	TXCOMP

- **TXCOMP:** Transmission Completed
- **RXRDY:** Receive Holding Register Ready
- **TXRDY:** Transmit Holding Register Ready
- **OVRE:** Overrun Error
- **UNRE:** Underrun Error
- **NACK:** Not Acknowledge

0 = No effect.

1 = Enables the corresponding interrupt.

29.6.7 TWI Interrupt Disable Register

Register Name: TWI_IDR

Access Type: Write-only

31	30	29	28	27	26	25	24
–	–	–	–	–	–	–	–
23	22	21	20	19	18	17	16
–	–	–	–	–	–	–	–
15	14	13	12	11	10	9	8
–	–	–	–	–	–	–	NACK
7	6	5	4	3	2	1	0
UNRE	OVRE	–	–	–	TXRDY	RXRDY	TXCOMP

- **TXCOMP:** Transmission Completed
- **RXRDY:** Receive Holding Register Ready
- **TXRDY:** Transmit Holding Register Ready
- **OVRE:** Overrun Error
- **UNRE:** Underrun Error
- **NACK:** Not Acknowledge

0 = No effect.

1 = Disables the corresponding interrupt.

29.6.8 TWI Interrupt Mask Register

Register Name: TWI_IMR

Access Type: Read-only

31	30	29	28	27	26	25	24
–	–	–	–	–	–	–	–
23	22	21	20	19	18	17	16
–	–	–	–	–	–	–	–
15	14	13	12	11	10	9	8
–	–	–	–	–	–	–	NACK
7	6	5	4	3	2	1	0
UNRE	OVRE	–	–	–	TXRDY	RXRDY	TXCOMP

- **TXCOMP:** Transmission Completed
- **RXRDY:** Receive Holding Register Ready
- **TXRDY:** Transmit Holding Register Ready
- **OVRE:** Overrun Error
- **UNRE:** Underrun Error
- **NACK:** Not Acknowledge

0 = The corresponding interrupt is disabled.

1 = The corresponding interrupt is enabled.

29.6.9 TWI Receive Holding Register

Register Name: TWI_RHR

Access Type: Read-only

31	30	29	28	27	26	25	24
–	–	–	–	–	–	–	–
23	22	21	20	19	18	17	16
–	–	–	–	–	–	–	–
15	14	13	12	11	10	9	8
–	–	–	–	–	–	–	–
7	6	5	4	3	2	1	0
RXDATA							

- **RXDATA:** Master or Slave Receive Holding Data

29.6.10 TWI Transmit Holding Register

Register Name: TWI_THR

Access Type: Read/Write

31	30	29	28	27	26	25	24
–	–	–	–	–	–	–	–
23	22	21	20	19	18	17	16
–	–	–	–	–	–	–	–
15	14	13	12	11	10	9	8
–	–	–	–	–	–	–	–
7	6	5	4	3	2	1	0
TXDATA							

- TXDATA: Master or Slave Transmit Holding Data

30. Universal Synchronous Asynchronous Receiver Transceiver (USART)

30.1 Overview

The Universal Synchronous Asynchronous Receiver Transceiver (USART) provides one full duplex universal synchronous asynchronous serial link. Data frame format is widely programmable (data length, parity, number of stop bits) to support a maximum of standards. The receiver implements parity error, framing error and overrun error detection. The receiver time-out enables handling variable-length frames and the transmitter timeguard facilitates communications with slow remote devices. Multi-drop communications are also supported through address bit handling in reception and transmission.

The USART features three test modes: remote loopback, local loopback and automatic echo.

The USART supports specific operating modes providing interfaces on RS485 busses, with ISO7816 T = 0 or T = 1 smart card slots, infrared transceivers and connection to modem ports. The hardware handshaking feature enables an out-of-band flow control by automatic management of the pins RTS and CTS.

The USART supports the connection to the Peripheral DMA Controller, which enables data transfers to the transmitter and from the receiver. The PDC provides chained buffer management without any intervention of the processor.

Important features of the USART are:

- Programmable Baud Rate Generator
- 5- to 9-bit Full-duplex Synchronous or Asynchronous Serial Communications⁽¹⁾
 - 1, 1.5 or 2 Stop Bits in Asynchronous Mode or 1 or 2 Stop Bits in Synchronous Mode
 - Parity Generation and Error Detection
 - Framing Error Detection, Overrun Error Detection
 - MSB- or LSB-first
 - Optional Break Generation and Detection
 - By 8 or by-16 Over-sampling Receiver Frequency
 - Optional Hardware Handshaking RTS-CTS
 - Optional Modem Signal Management DTR-DSR-DCD-RI
 - Receiver Time-out and Transmitter Timeguard
 - Optional Multi-Drop Mode with Address Generation and Detection
- RS485 with driver control signal
- ISO7816, T = 0 or T = 1 Protocols for Interfacing with Smart Cards
 - NACK Handling, Error Counter with Repetition and Iteration Limit
- IrDA Modulation and Demodulation
 - Communication at up to 115.2 Kbps
- Test Modes
 - Remote Loopback, Local Loopback, Automatic Echo
- Supports Connection of Two Peripheral DMA Controller Channels (PDC)
 - Offer Buffer Transfer without Processor Intervention

Note: 1. The 9-bit Character Length Mode cannot be used with the peripheral DMA Controller (PDC)



30.2 Block Diagram

Figure 30-1. USART Block Diagram

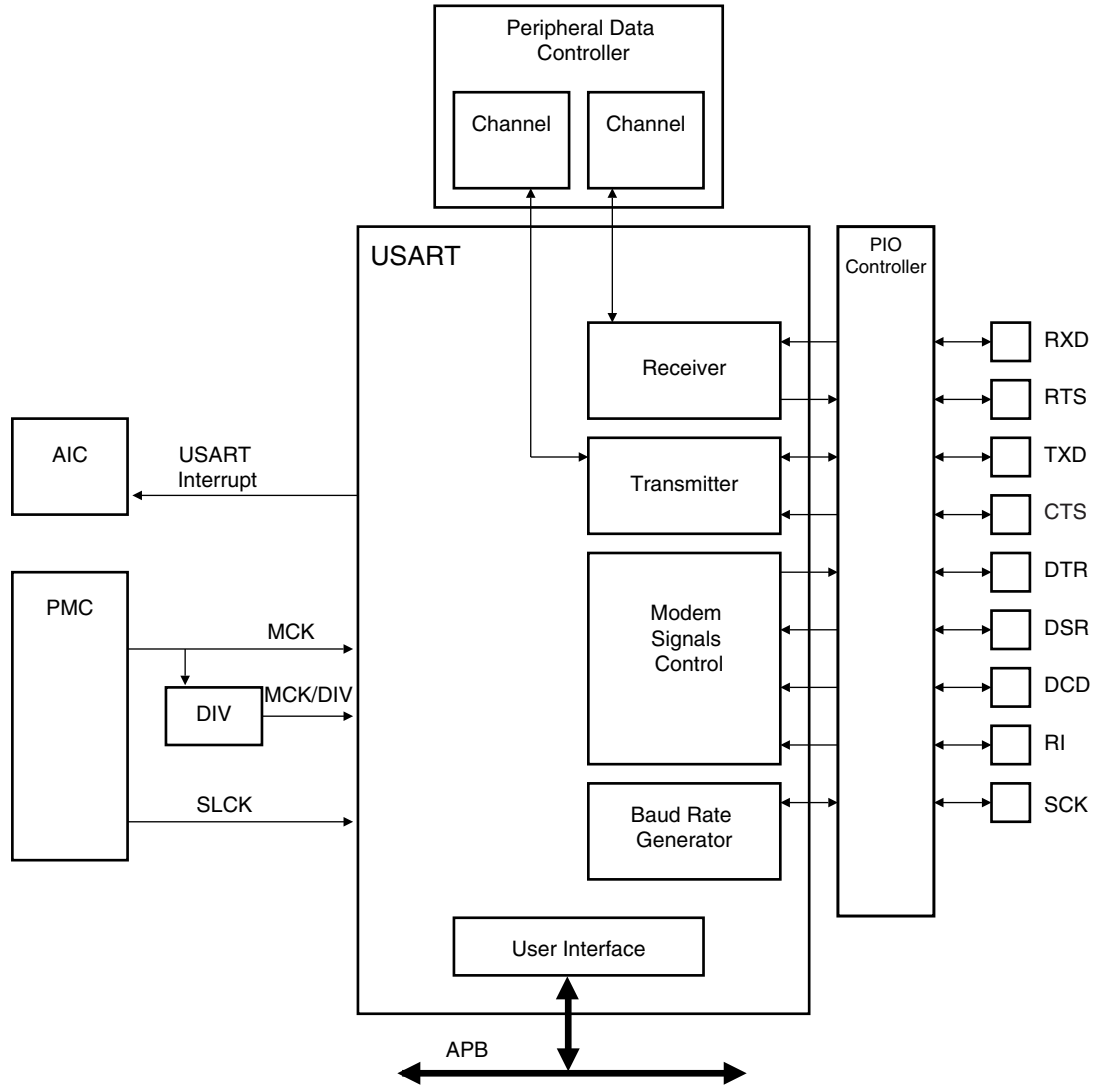

30.3 Application Block Diagram

Figure 30-2. Application Block Diagram

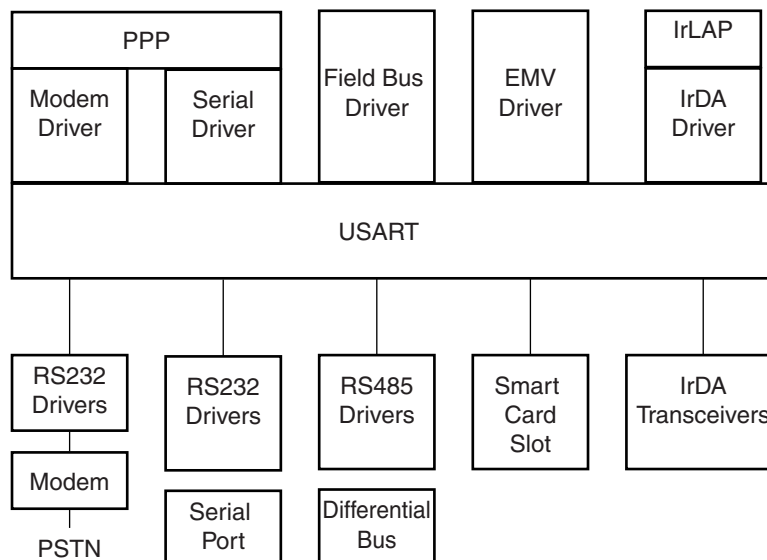

30.4 I/O Lines Description

Table 30-1. I/O Line Description

Name	Description	Type	Active Level
SCK	Serial Clock	I/O	
TXD	Transmit Serial Data	I/O	
RXD	Receive Serial Data	Input	
RI	Ring Indicator	Input	Low
DSR	Data Set Ready	Input	Low
DCD	Data Carrier Detect	Input	Low
DTR	Data Terminal Ready	Output	Low
CTS	Clear to Send	Input	Low
RTS	Request to Send	Output	Low

30.5 Product Dependencies

30.5.1 I/O Lines

The pins used for interfacing the USART may be multiplexed with the PIO lines. The programmer must first program the PIO controller to assign the desired USART pins to their peripheral function. If I/O lines of the USART are not used by the application, they can be used for other purposes by the PIO Controller.

All the pins of the modems may or may not be implemented on the USART within a product. Frequently, only the USART1 is fully equipped with all the modem signals. For the other USARTs of the product not equipped with the corresponding pin, the associated control bits and statuses have no effect on the behavior of the USART.

30.5.2 Power Management

The USART is not continuously clocked. The programmer must first enable the USART Clock in the Power Management Controller (PMC) before using the USART. However, if the application does not require USART operations, the USART clock can be stopped when not needed and be restarted later. In this case, the USART will resume its operations where it left off.

Configuring the USART does not require the USART clock to be enabled.

30.5.3 Interrupt

The USART interrupt line is connected on one of the internal sources of the Advanced Interrupt Controller. Using the USART interrupt requires the AIC to be programmed first. Note that it is not recommended to use the USART interrupt line in edge sensitive mode.

30.6 Functional Description

The USART is capable of managing several types of serial synchronous or asynchronous communications.

It supports the following communication modes.

- 5- to 9-bit full-duplex asynchronous serial communication:
 - MSB- or LSB-first
 - 1, 1.5 or 2 stop bits
 - Parity even, odd, marked, space or none
 - By-8 or by-16 over-sampling receiver frequency
 - Optional hardware handshaking
 - Optional modem signals management
 - Optional break management
 - Optional multi-drop serial communication
- High-speed 5- to 9-bit full-duplex synchronous serial communication:
 - MSB- or LSB-first
 - 1 or 2 stop bits
 - Parity even, odd, marked, space or none
 - by 8 or by-16 over-sampling frequency
 - Optional Hardware handshaking
 - Optional Modem signals management
 - Optional Break management
 - Optional Multi-Drop serial communication
- RS485 with driver control signal
- ISO7816, T0 or T1 protocols for interfacing with smart cards
 - NACK handling, error counter with repetition and iteration limit
- InfraRed IrDA Modulation and Demodulation
- Test modes
 - remote loopback, local loopback, automatic echo

30.6.1 Baud Rate Generator

The Baud Rate Generator provides the bit period clock named the Baud Rate Clock to both the receiver and the transmitter.

The Baud Rate Generator clock source can be selected by setting the USCLKS field in the Mode Register (US_MR) between:

- the Master Clock MCK
- A division of the Master Clock, the divider being product dependent, but generally set to 8
- the external clock, available on the SCK pin

The Baud Rate Generator is based upon a 16-bit divider, which is programmed with the CD field of the Baud Rate Generator Register (US_BRGR). If CD is programmed at 0, the Baud Rate Generator does not generate any clock. If CD is programmed at 1, the divider is bypassed and becomes inactive.

If the external SCK clock is selected, the duration of the low and high levels of the signal provided on the SCK pin must be longer than a Master Clock (MCK) period. The frequency of the signal provided on SCK must be at least 4.5 times lower than MCK.

Figure 30-3. Baud Rate Generator

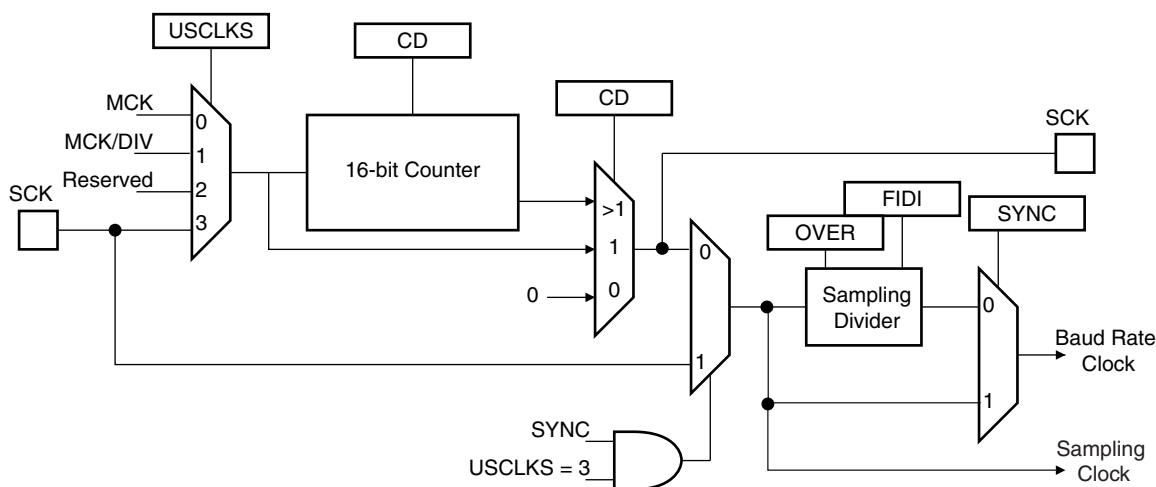

30.6.1.1 Baud Rate in Asynchronous Mode

If the USART is programmed to operate in asynchronous mode, the selected clock is first divided by CD, which is field programmed in the Baud Rate Generator Register (US_BRGR). The resulting clock is provided to the receiver as a sampling clock and then divided by 16 or 8, depending on the programming of the OVER bit in US_MR.

If OVER is set to 1, the receiver sampling is 8 times higher than the baud rate clock. If OVER is cleared, the sampling is performed at 16 times the baud rate clock.

The following formula performs the calculation of the Baud Rate.

$$\text{Baudrate} = \frac{\text{SelectedClock}}{(8(2 - \text{Over})CD)}$$

This gives a maximum baud rate of MCK divided by 8, assuming that MCK is the highest possible clock and that OVER is programmed at 1.

Baud Rate Calculation Example

Table 30-2 shows calculations of CD to obtain a baud rate at 38400 bauds for different source clock frequencies. This table also shows the actual resulting baud rate and the error.

Table 30-2. Baud Rate Example (OVER = 0)

Source Clock	Expected Baud Rate	Calculation Result	CD	Actual Baud Rate	Error
MHz	Bit/s			Bit/s	
3 686 400	38 400	6.00	6	38 400.00	0.00%
4 915 200	38 400	8.00	8	38 400.00	0.00%
5 000 000	38 400	8.14	8	39 062.50	1.70%
7 372 800	38 400	12.00	12	38 400.00	0.00%
8 000 000	38 400	13.02	13	38 461.54	0.16%
12 000 000	38 400	19.53	20	37 500.00	2.40%
12 288 000	38 400	20.00	20	38 400.00	0.00%
14 318 180	38 400	23.30	23	38 908.10	1.31%
14 745 600	38 400	24.00	24	38 400.00	0.00%
18 432 000	38 400	30.00	30	38 400.00	0.00%
24 000 000	38 400	39.06	39	38 461.54	0.16%
24 576 000	38 400	40.00	40	38 400.00	0.00%
25 000 000	38 400	40.69	40	38 109.76	0.76%
32 000 000	38 400	52.08	52	38 461.54	0.16%
32 768 000	38 400	53.33	53	38 641.51	0.63%
33 000 000	38 400	53.71	54	38 194.44	0.54%
40 000 000	38 400	65.10	65	38 461.54	0.16%
50 000 000	38 400	81.38	81	38 580.25	0.47%
60 000 000	38 400	97.66	98	38 265.31	0.35%
70 000 000	38 400	113.93	114	38 377.19	0.06%

The baud rate is calculated with the following formula:

$$\text{BaudRate} = \text{MCK} / \text{CD} \times 16$$

The baud rate error is calculated with the following formula. It is not recommended to work with an error higher than 5%.

$$\text{Error} = 1 - \left(\frac{\text{ExpectedBaudRate}}{\text{ActualBaudRate}} \right)$$

30.6.1.2 Baud Rate in Synchronous Mode

If the USART is programmed to operate in synchronous mode, the selected clock is simply divided by the field CD in US_BRGR.

$$\text{BaudRate} = \frac{\text{SelectedClock}}{CD}$$

In synchronous mode, if the external clock is selected (USCLKS = 3), the clock is provided directly by the signal on the USART SCK pin. No division is active. The value written in US_BRGR has no effect. The external clock frequency must be at least 4.5 times lower than the system clock.

When either the external clock SCK or the internal clock divided (MCK/DIV) is selected, the value programmed in CD must be even if the user has to ensure a 50:50 mark/space ratio on the SCK pin. If the internal clock MCK is selected, the Baud Rate Generator ensures a 50:50 duty cycle on the SCK pin, even if the value programmed in CD is odd.

30.6.1.3 Baud Rate in ISO 7816 Mode

The ISO7816 specification defines the bit rate with the following formula:

$$B = \frac{Di}{Fi} \times f$$

where:

- B is the bit rate
- Di is the bit-rate adjustment factor
- Fi is the clock frequency division factor
- f is the ISO7816 clock frequency (Hz)

Di is a binary value encoded on a 4-bit field, named DI, as represented in [Table 30-3](#).

Table 30-3. Binary and Decimal Values for D

DI field	0001	0010	0011	0100	0101	0110	1000	1001
Di (decimal)	1	2	4	8	16	32	12	20

Fi is a binary value encoded on a 4-bit field, named FI, as represented in [Table 30-4](#).

Table 30-4. Binary and Decimal Values for F

FI field	0000	0001	0010	0011	0100	0101	0110	1001	1010	1011	1100	1101
Fi (decimal)	372	372	558	744	1116	1488	1860	512	768	1024	1536	2048

[Table 30-5](#) shows the resulting Fi/Di Ratio, which is the ratio between the ISO7816 clock and the baud rate clock.

Table 30-5. Possible Values for the Fi/Di Ratio

Fi/Di	372	558	774	1116	1488	1806	512	768	1024	1536	2048
1	372	558	744	1116	1488	1860	512	768	1024	1536	2048
2	186	279	372	558	744	930	256	384	512	768	1024
4	93	139.5	186	279	372	465	128	192	256	384	512
8	46.5	69.75	93	139.5	186	232.5	64	96	128	192	256
16	23.25	34.87	46.5	69.75	93	116.2	32	48	64	96	128

Table 30-5. Possible Values for the Fi/Di Ratio (Continued)

32	11.62	17.43	23.25	34.87	46.5	58.13	16	24	32	48	64
12	31	46.5	62	93	124	155	42.66	64	85.33	128	170.6
20	18.6	27.9	37.2	55.8	74.4	93	25.6	38.4	51.2	76.8	102.4

If the USART is configured in ISO7816 Mode, the clock selected by the USCLKS field in the Mode Register (US_MR) is first divided by the value programmed in the field CD in the Baud Rate Generator Register (US_BRGR). The resulting clock can be provided to the SCK pin to feed the smart card clock inputs. This means that the CLKO bit can be set in US_MR.

This clock is then divided by the value programmed in the FI_DI_RATIO field in the FI_DI_Ratio register (US_FIDI). This is performed by the Sampling Divider, which performs a division by up to 2047 in ISO7816 Mode. The non-integer values of the Fi/Di Ratio are not supported and the user must program the FI_DI_RATIO field to a value as close as possible to the expected value.

The FI_DI_RATIO field resets to the value 0x174 (372 in decimal) and is the most common divider between the ISO7816 clock and the bit rate (Fi = 372, Di = 1).

Figure 30-4 shows the relation between the Elementary Time Unit, corresponding to a bit time, and the ISO 7816 clock.

Figure 30-4. Elementary Time Unit (ETU)

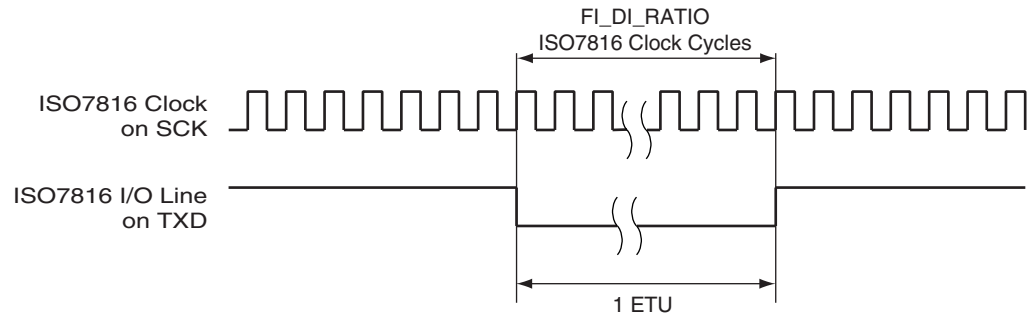

30.6.2 Receiver and Transmitter Control

After reset, the receiver is disabled. The user must enable the receiver by setting the RXEN bit in the Control Register (US_CR). However, the receiver registers can be programmed before the receiver clock is enabled.

After reset, the transmitter is disabled. The user must enable it by setting the TXEN bit in the Control Register (US_CR). However, the transmitter registers can be programmed before being enabled.

The Receiver and the Transmitter can be enabled together or independently.

At any time, the software can perform a reset on the receiver or the transmitter of the USART by setting the corresponding bit, RSTRX and RSTTX respectively, in the Control Register (US_CR). The reset commands have the same effect as a hardware reset on the corresponding logic. Regardless of what the receiver or the transmitter is performing, the communication is immediately stopped.

The user can also independently disable the receiver or the transmitter by setting RXDIS and TXDIS respectively in US_CR. If the receiver is disabled during a character reception, the USART waits until the end of reception of the current character, then the reception is stopped. If

the transmitter is disabled while it is operating, the USART waits the end of transmission of both the current character and character being stored in the Transmit Holding Register (US_THR). If a time guard is programmed, it is handled normally.

30.6.3 Synchronous and Asynchronous Modes

30.6.3.1 Transmitter Operations

The transmitter performs the same in both synchronous and asynchronous operating modes (SYNC = 0 or SYNC = 1). One start bit, up to 9 data bits, one optional parity bit and up to two stop bits are successively shifted out on the TXD pin at each falling edge of the programmed serial clock.

The number of data bits is selected by the CHRL field and the MODE9 bit in the Mode Register (US_MR). Nine bits are selected by setting the MODE 9 bit regardless of the CHRL field. The parity bit is set according to the PAR field in US_MR. The even, odd, space, marked or none parity bit can be configured. The MSBF field in US_MR configures which data bit is sent first. If written at 1, the most significant bit is sent first. At 0, the less significant bit is sent first. The number of stop bits is selected by the NBSTOP field in US_MR. The 1.5 stop bit is supported in asynchronous mode only.

Figure 30-5. Character Transmit

Example: 8-bit, Parity Enabled One Stop

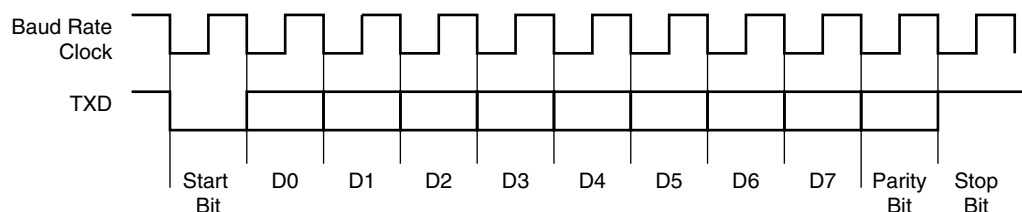

The characters are sent by writing in the Transmit Holding Register (US_THR). The transmitter reports two status bits in the Channel Status Register (US_CSR): TXRDY (Transmitter Ready), which indicates that US_THR is empty and TXEMPTY, which indicates that all the characters written in US_THR have been processed. When the current character processing is completed, the last character written in US_THR is transferred into the Shift Register of the transmitter and US_THR becomes empty, thus TXRDY raises.

Both TXRDY and TXEMPTY bits are low since the transmitter is disabled. Writing a character in US_THR while TXRDY is active has no effect and the written character is lost.

Figure 30-6. Transmitter Status

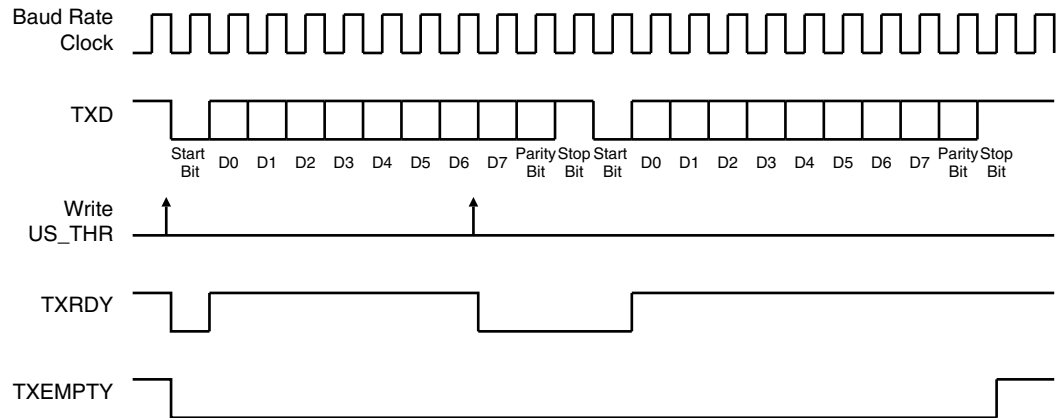

30.6.3.2 Asynchronous Receiver

If the USART is programmed in asynchronous operating mode ($SYNC = 0$), the receiver oversamples the RXD input line. The oversampling is either 16 or 8 times the Baud Rate clock, depending on the OVER bit in the Mode Register (US_MR).

The receiver samples the RXD line. If the line is sampled during one half of a bit time at 0, a start bit is detected and data, parity and stop bits are successively sampled on the bit rate clock.

If the oversampling is 16, (OVER at 0), a start is detected at the eighth sample at 0. Then, data bits, parity bit and stop bit are sampled on each 16 sampling clock cycle. If the oversampling is 8 (OVER at 1), a start bit is detected at the fourth sample at 0. Then, data bits, parity bit and stop bit are sampled on each 8 sampling clock cycle.

The number of data bits, first bit sent and parity mode are selected by the same fields and bits as the transmitter, i.e. respectively CHRL, MODE9, MSBF and PAR. The number of stop bits has no effect on the receiver as it considers only one stop bit, regardless of the field NBSTOP, so that resynchronization between the receiver and the transmitter can occur. Moreover, as soon as the stop bit is sampled, the receiver starts looking for a new start bit so that resynchronization can also be accomplished when the transmitter is operating with one stop bit.

Figure 30-7 and Figure 30-8 illustrate start detection and character reception when USART operates in asynchronous mode.

Figure 30-7. Asynchronous Start Detection

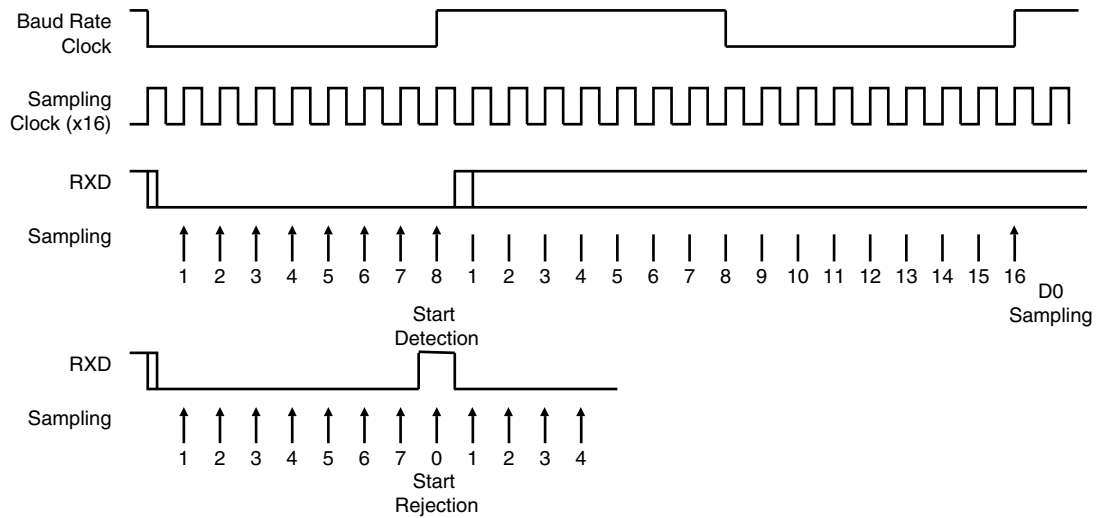
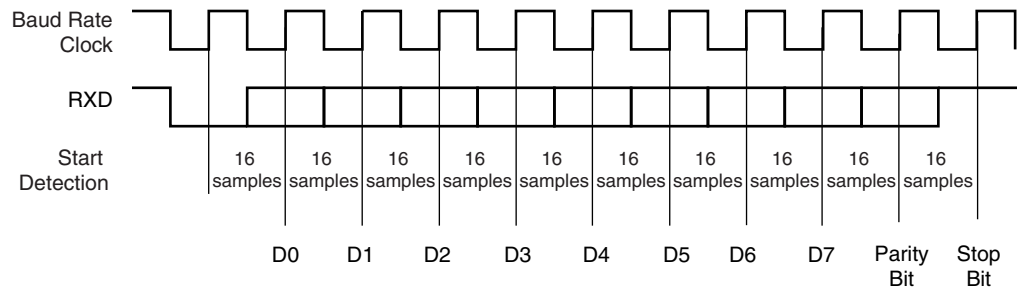

Figure 30-8. Asynchronous Character Reception

Example: 8-bit, Parity Enabled



30.6.3.3 Synchronous Receiver

In synchronous mode (SYNC = 1), the receiver samples the RXD signal on each rising edge of the Baud Rate Clock. If a low level is detected, it is considered as a start. All data bits, the parity bit and the stop bits are sampled and the receiver waits for the next start bit. Synchronous mode operations provide a high speed transfer capability.

Configuration fields and bits are the same as in asynchronous mode.

Figure 30-9 illustrates a character reception in synchronous mode.

Figure 30-9. Synchronous Mode Character Reception

Example: 8-bit, Parity Enabled 1 Stop

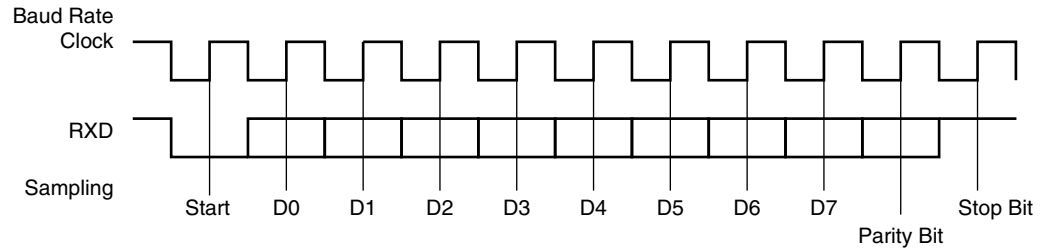

30.6.3.4 Receiver Operations

When a character reception is completed, it is transferred to the Receive Holding Register (US_RHR) and the RXRDY bit in the Status Register (US_CSR) rises. If a character is completed while the RXRDY is set, the OVRE (Overrun Error) bit is set. The last character is transferred into US_RHR and overwrites the previous one. The OVRE bit is cleared by writing the Control Register (US_CR) with the RSTSTA (Reset Status) bit at 1.

Figure 30-10. Receiver Status

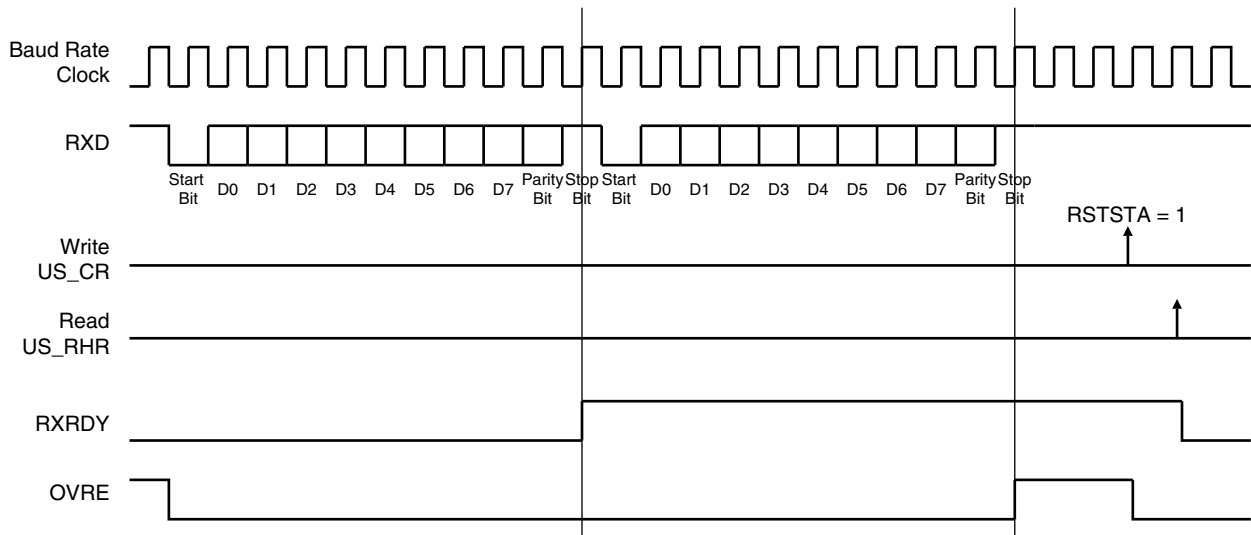

30.6.3.5 Parity

The USART supports five parity modes selected by programming the PAR field in the Mode Register (US_MR). The PAR field also enables the Multi-drop Mode, see [“Multi-drop Mode” on page 423](#). Even and odd parity bit generation and error detection are supported.

If even parity is selected, the parity generator of the transmitter drives the parity bit at 0 if a number of 1s in the character data bit is even, and at 1 if the number of 1s is odd. Accordingly, the receiver parity checker counts the number of received 1s and reports a parity error if the sampled parity bit does not correspond. If odd parity is selected, the parity generator of the transmitter drives the parity bit at 1 if a number of 1s in the character data bit is even, and at 0 if the number of 1s is odd. Accordingly, the receiver parity checker counts the number of received 1s and reports a parity error if the sampled parity bit does not correspond. If the mark parity is used, the parity generator of the transmitter drives the parity bit at 1 for all characters. The receiver parity checker reports an error if the parity bit is sampled at 0. If the space parity is

used, the parity generator of the transmitter drives the parity bit at 0 for all characters. The receiver parity checker reports an error if the parity bit is sampled at 1. If parity is disabled, the transmitter does not generate any parity bit and the receiver does not report any parity error.

Table 30-6 shows an example of the parity bit for the character 0x41 (character ASCII “A”) depending on the configuration of the USART. Because there are two bits at 1, 1 bit is added when a parity is odd, or 0 is added when a parity is even. I

Table 30-6. Parity Bit Examples

Character	Hexa	Binary	Parity Bit	Parity Mode
A	0x41	0100 0001	1	Odd
A	0x41	0100 0001	0	Even
A	0x41	0100 0001	1	Mark
A	0x41	0100 0001	0	Space
A	0x41	0100 0001	None	None

When the receiver detects a parity error, it sets the PARE (Parity Error) bit in the Channel Status Register (US_CSR). The PARE bit can be cleared by writing the Control Register (US_CR) with the RSTSTA bit at 1. Figure 30-11 illustrates the parity bit status setting and clearing.

Figure 30-11. Parity Error

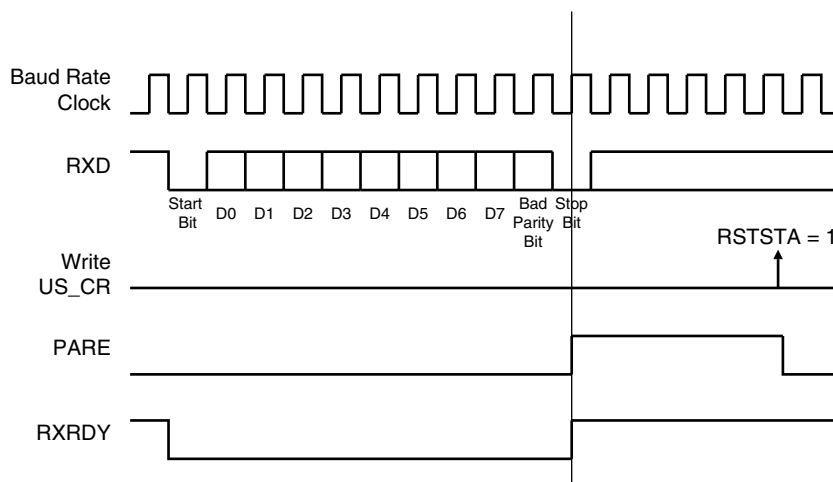

30.6.3.6 Multi-drop Mode

If the PAR field in the Mode Register (US_MR) is programmed to the value 0x6 or 0x7, the USART runs in Multi-drop mode. This mode differentiates the data characters and the address characters. Data is transmitted with the parity bit at 0 and addresses are transmitted with the parity bit at 1.

If the USART is configured in multi-drop mode, the receiver sets the PARE parity error bit when the parity bit is high and the transmitter is able to send a character with the parity bit high when the Control Register is written with the SENDA bit at 1.

To handle parity error, the PARE bit is cleared when the Control Register is written with the bit RSTSTA at 1.

The transmitter sends an address byte (parity bit set) when SENDA is written to US_CR. In this case, the next byte written to US_THR is transmitted as an address. Any character written in US_THR without having written the command SENDA is transmitted normally with the parity at 0.

30.6.3.7 Transmitter Timeguard

The timeguard feature enables the USART interface with slow remote devices.

The timeguard function enables the transmitter to insert an idle state on the TXD line between two characters. This idle state actually acts as a long stop bit.

The duration of the idle state is programmed in the TG field of the Transmitter Timeguard Register (US_TTGR). When this field is programmed at zero no timeguard is generated. Otherwise, the transmitter holds a high level on TXD after each transmitted byte during the number of bit periods programmed in TG in addition to the number of stop bits.

As illustrated in Figure 30-12, the behavior of TXRDY and TXEMPTY status bits is modified by the programming of a timeguard. TXRDY rises only when the start bit of the next character is sent, and thus remains at 0 during the timeguard transmission if a character has been written in US_THR. TXEMPTY remains low until the timeguard transmission is completed as the timeguard is part of the current character being transmitted.

Figure 30-12. Timeguard Operations

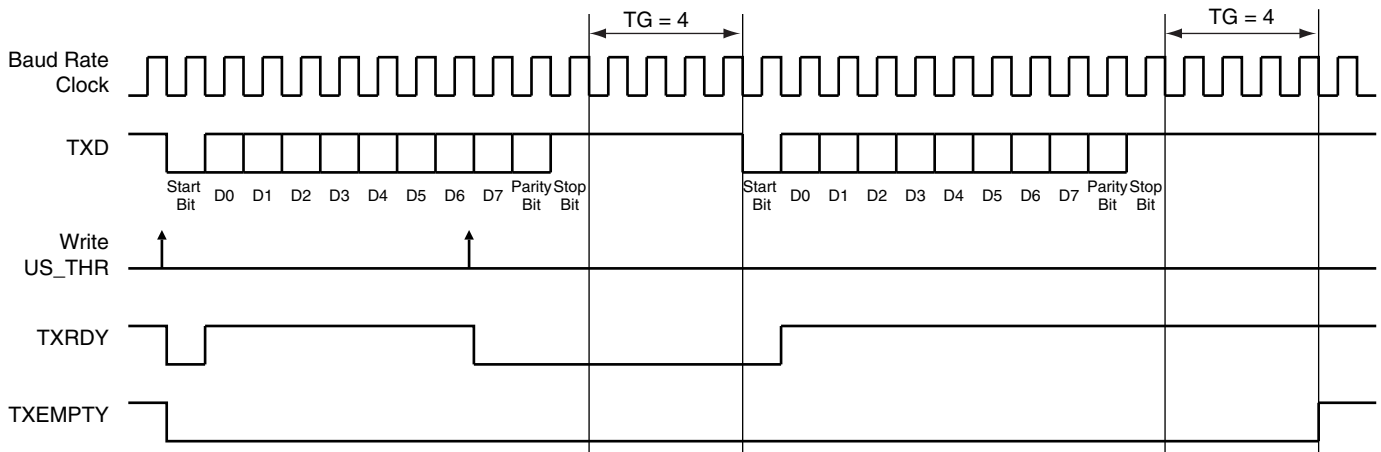

Table 30-7 indicates the maximum length of a timeguard period that the transmitter can handle in relation to the function of the Baud Rate.

Table 30-7. Maximum Timeguard Length Depending on Baud Rate

Baud Rate	Bit time	Timeguard
bit/sec	μs	ms
1 200	833	212.50
9 600	104	26.56
14400	69.4	17.71
19200	52.1	13.28
28800	34.7	8.85
33400	29.9	7.63

Table 30-7. Maximum Timeguard Length Depending on Baud Rate (Continued)

Baud Rate	Bit time	Timeguard
56000	17.9	4.55
57600	17.4	4.43
115200	8.7	2.21

30.6.3.8 Receiver Time-out

The Receiver Time-out provides support in handling variable-length frames. This feature detects an idle condition on the RXD line. When a time-out is detected, the bit TIMEOUT in the Channel Status Register (US_CSR) rises and can generate an interrupt, thus indicating to the driver an end of frame.

The time-out delay period (during which the receiver waits for a new character) is programmed in the TO field of the Receiver Time-out Register (US_RTOR). If the TO field is programmed at 0, the Receiver Time-out is disabled and no time-out is detected. The TIMEOUT bit in US_CSR remains at 0. Otherwise, the receiver loads a 16-bit counter with the value programmed in TO. This counter is decremented at each bit period and reloaded each time a new character is received. If the counter reaches 0, the TIMEOUT bit in the Status Register rises.

The user can either:

- Obtain an interrupt when a time-out is detected after having received at least one character. This is performed by writing the Control Register (US_CR) with the STTTO (Start Time-out) bit at 1.
- Obtain a periodic interrupt while no character is received. This is performed by writing US_CR with the RETTO (Reload and Start Time-out) bit at 1.

If STTTO is performed, the counter clock is stopped until a first character is received. The idle state on RXD before the start of the frame does not provide a time out. This prevents having to obtain a periodic interrupt and enables a wait of the end of frame when the idle state on RXD is detected.

If RETTO is performed, the counter starts counting down immediately from the value TO. This enables generation of a periodic interrupt so that a user time-out can be handled, for example when no key is pressed on a keyboard.

Figure 30-13 shows the block diagram of the Receiver Time out feature.

Figure 30-13. Receiver Time-out Block Diagram

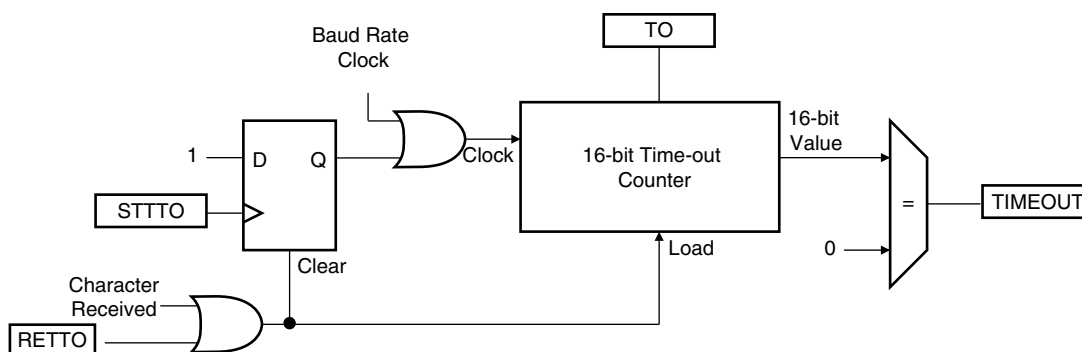

Table 30-8 gives the maximum time-out period for some standard baud rates.

Table 30-8. Maximum Time-out Period

Baud Rate	Bit Time	Time -out
bit/sec	μ s	ms
600	1 667	109 225
1 200	833	54 613
2 400	417	27 306
4 800	208	13 653
9 600	104	6 827
14400	69	4 551
19200	52	3 413
28800	35	2 276
33400	30	1 962
56000	18	1 170
57600	17	1 138
200000	5	328

30.6.3.9 Framing Error

The receiver is capable of detecting framing errors. A framing error happens when the stop bit of a received character is detected at level 0. This can occur if the receiver and the transmitter are fully desynchronized.

A framing error is reported on the FRAME bit of the Channel Status Register (US_CSR). The FRAME bit is asserted in the middle of the stop bit as soon as the framing error is detected. It is cleared by writing the Control Register (US_CR) with the RSTSTA bit at 1.

Figure 30-14. Framing Error Status

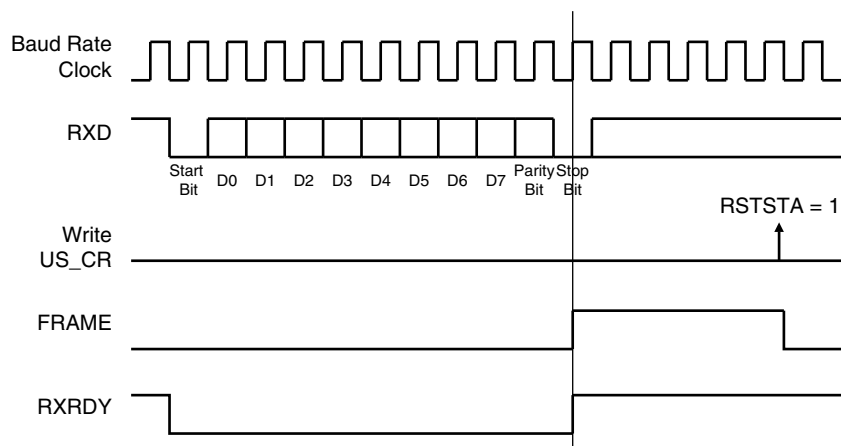

30.6.3.10 Transmit Break

The user can request the transmitter to generate a break condition on the TXD line. A break condition drives the TXD line low during at least one complete character. It appears the same as a

0x00 character sent with the parity and the stop bits at 0. However, the transmitter holds the TXD line at least during one character until the user requests the break condition to be removed.

A break is transmitted by writing the Control Register (US_CR) with the STTBK bit at 1. This can be performed at any time, either while the transmitter is empty (no character in either the Shift Register or in US_THR) or when a character is being transmitted. If a break is requested while a character is being shifted out, the character is first completed before the TXD line is held low.

Once STTBK command is requested further STTBK commands are ignored until the end of the break is completed.

The break condition is removed by writing US_CR with the STPBK bit at 1. If the STPBK is requested before the end of the minimum break duration (one character, including start, data, parity and stop bits), the transmitter ensures that the break condition completes.

The transmitter considers the break as though it is a character, i.e. the STTBK and STPBK commands are taken into account only if the TXRDY bit in US_CSR is at 1 and the start of the break condition clears the TXRDY and TXEMPTY bits as if a character is processed.

Writing US_CR with the both STTBK and STPBK bits at 1 can lead to an unpredictable result. All STPBK commands requested without a previous STTBK command are ignored. A byte written into the Transmit Holding Register while a break is pending, but not started, is ignored.

After the break condition, the transmitter returns the TXD line to 1 for a minimum of 12 bit times. Thus, the transmitter ensures that the remote receiver detects correctly the end of break and the start of the next character. If the timeguard is programmed with a value higher than 12, the TXD line is held high for the timeguard period.

After holding the TXD line for this period, the transmitter resumes normal operations.

Figure 30-15 illustrates the effect of both the Start Break (STTBK) and Stop Break (STP BRK) commands on the TXD line.

Figure 30-15. Break Transmission

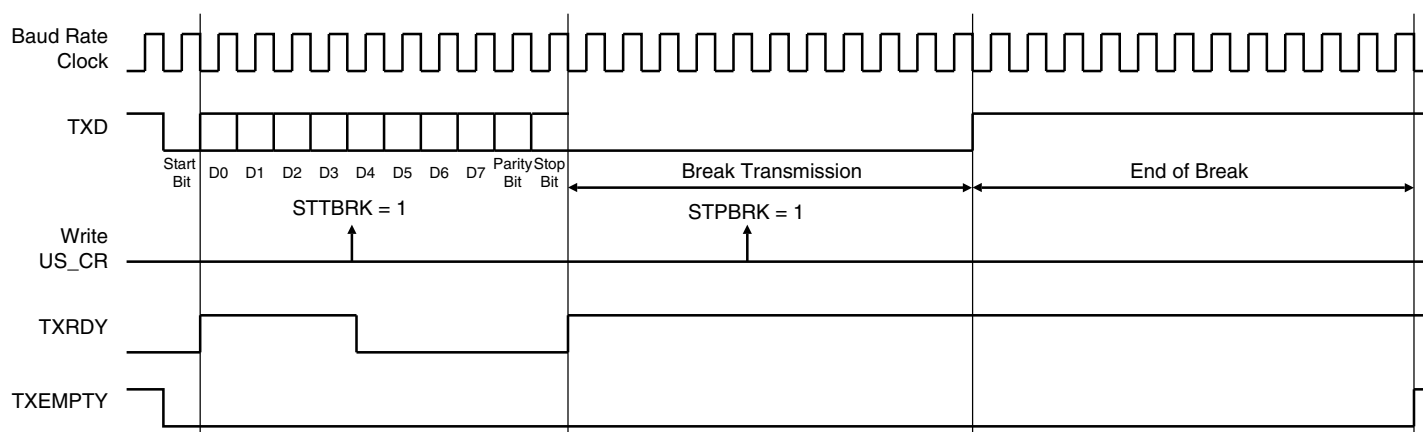

30.6.3.11 Receive Break

The receiver detects a break condition when all data, parity and stop bits are low. This corresponds to detecting a framing error with data at 0x00, but FRAME remains low.

When the low stop bit is detected, the receiver asserts the RXBRK bit in US_CSR. This bit may be cleared by writing the Control Register (US_CR) with the bit RSTSTA at 1.

An end of receive break is detected by a high level for at least 2/16 of a bit period in asynchronous operating mode or one sample at high level in synchronous operating mode. The end of break detection also asserts the RXBRK bit.

30.6.3.12 Hardware Handshaking

The USART features a hardware handshaking out-of-band flow control. The RTS and CTS pins are used to connect with the remote device, as shown in [Figure 30-16](#).

Figure 30-16. Connection with a Remote Device for Hardware Handshaking

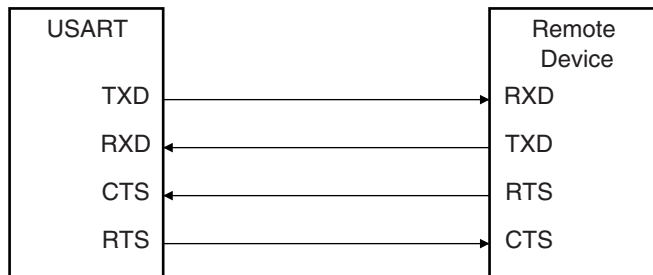

Setting the USART to operate with hardware handshaking is performed by writing the USART_MODE field in the Mode Register (US_MR) to the value 0x2.

The USART behavior when hardware handshaking is enabled is the same as the behavior in standard synchronous or asynchronous mode, except that the receiver drives the RTS pin as described below and the level on the CTS pin modifies the behavior of the transmitter as described below. Using this mode requires using the PDC channel for reception. The transmitter can handle hardware handshaking in any case.

[Figure 30-17](#) shows how the receiver operates if hardware handshaking is enabled. The RTS pin is driven high if the receiver is disabled and if the status RXBUFF (Receive Buffer Full) coming from the PDC channel is high. Normally, the remote device does not start transmitting while its CTS pin (driven by RTS) is high. As soon as the Receiver is enabled, the RTS falls, indicating to the remote device that it can start transmitting. Defining a new buffer to the PDC clears the status bit RXBUFF and, as a result, asserts the pin RTS low.

Figure 30-17. Receiver Behavior when Operating with Hardware Handshaking

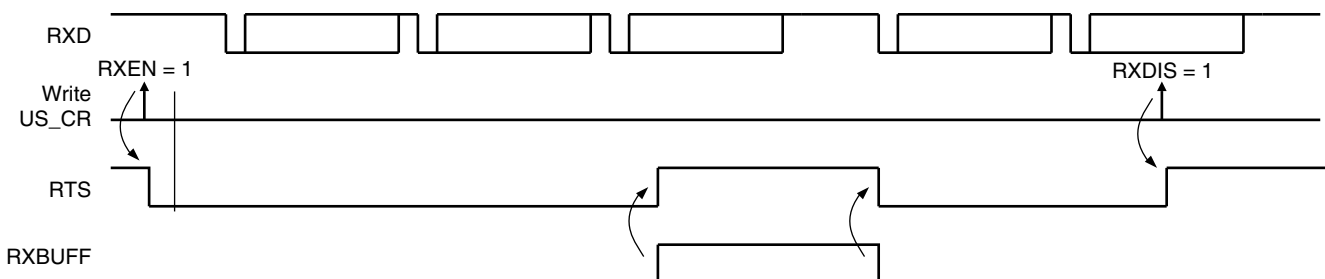

[Figure 30-18](#) shows how the transmitter operates if hardware handshaking is enabled. The CTS pin disables the transmitter. If a character is being processing, the transmitter is disabled only after the completion of the current character and transmission of the next character happens as soon as the pin CTS falls.

Figure 30-18. Transmitter Behavior when Operating with Hardware Handshaking



30.6.4 ISO7816 Mode

The USART features an ISO7816-compatible operating mode. This mode permits interfacing with smart cards and Security Access Modules (SAM) communicating through an ISO7816 link. Both T = 0 and T = 1 protocols defined by the ISO7816 specification are supported.

Setting the USART in ISO7816 mode is performed by writing the USART_MODE field in the Mode Register (US_MR) to the value 0x4 for protocol T = 0 and to the value 0x5 for protocol T = 1.

30.6.4.1 ISO7816 Mode overview

The ISO7816 is a half duplex communication on only one bidirectional line. The baud rate is determined by a division of the clock provided to the remote device (see [“Baud Rate Generator” on page 415](#)).

The USART connects to a smart card, as shown in [Figure 30-19](#). The TXD line becomes bidirectional and the Baud Rate Generator feeds the ISO7816 clock on the SCK pin. As the TXD pin becomes bidirectional, its output remains driven by the output of the transmitter but only when the transmitter is active while its input is directed to the input of the receiver. The USART is considered as the master of the communication as it generates the clock.

Figure 30-19. Connection of a Smart Card to the USART

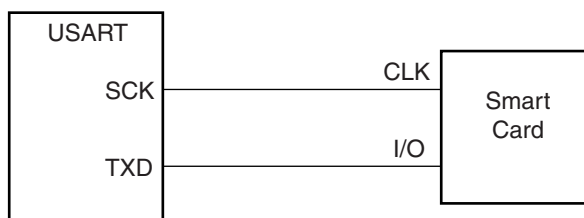

When operating in ISO7816, either in T = 0 or T = 1 modes, the character format is fixed. The configuration is 8 data bits, even parity and 1 or 2 stop bits, regardless of the values programmed in the CHRL, MODE9, PAR and CHMODE fields. MSBF can be used to transmit LSB or MSB first.

The USART cannot operate concurrently in both receiver and transmitter modes as the communication is unidirectional at a time. It has to be configured according to the required mode by enabling or disabling either the receiver or the transmitter as desired. Enabling both the receiver and the transmitter at the same time in ISO7816 mode may lead to unpredictable results.

The ISO7816 specification defines an inverse transmission format. Data bits of the character must be transmitted on the I/O line at their negative value. The USART does not support this format and the user has to perform an exclusive OR on the data before writing it in the Transmit Holding Register (US_THR) or after reading it in the Receive Holding Register (US_RHR).

30.6.4.2 Protocol $T = 0$

In $T = 0$ protocol, a character is made up of one start bit, eight data bits, one parity bit and one guard time, which lasts two bit times. The transmitter shifts out the bits and does not drive the I/O line during the guard time.

If no parity error is detected, the I/O line remains at 1 during the guard time and the transmitter can continue with the transmission of the next character, as shown in [Figure 30-20](#).

If a parity error is detected by the receiver, it drives the I/O line at 0 during the guard time, as shown in [Figure 30-21](#). This error bit is also named NACK, for Non Acknowledge. In this case, the character lasts 1 bit time more, as the guard time length is the same and is added to the error bit time which lasts 1 bit time.

When the USART is the receiver and it detects an error, it does not load the erroneous character in the Receive Holding Register (US_RHR). It appropriately sets the PARE bit in the Status Register (US_SR) so that the software can handle the error.

Figure 30-20. $T = 0$ Protocol without Parity Error

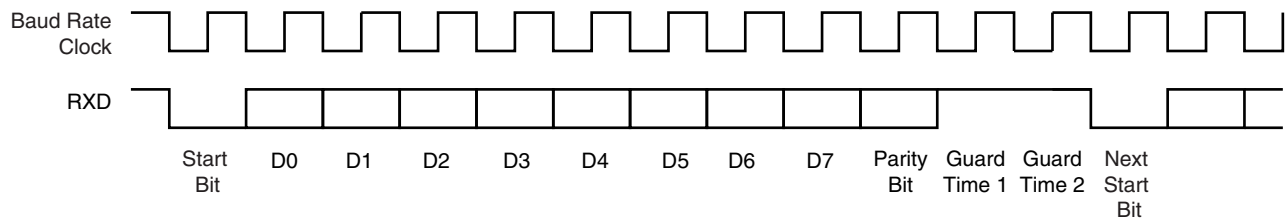
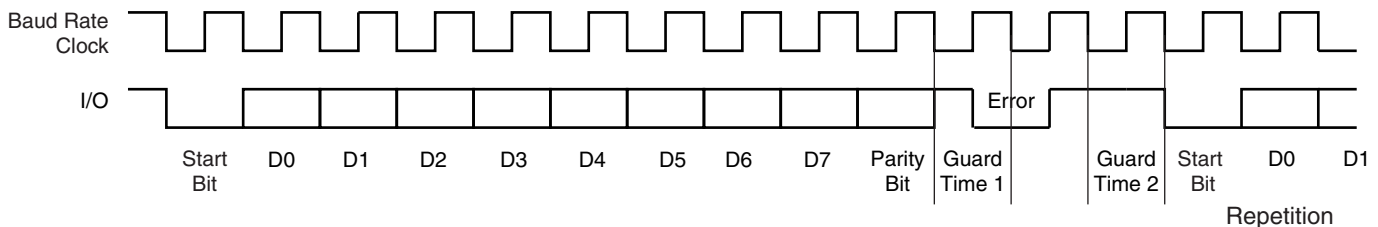

Figure 30-21. $T = 0$ Protocol with Parity Error



Receive Error Counter

The USART receiver also records the total number of errors. This can be read in the Number of Error (US_NER) register. The NB_ERRORS field can record up to 255 errors. Reading US_NER automatically clears the NB_ERRORS field.

Receive NACK Inhibit

The USART can also be configured to inhibit an error. This can be achieved by setting the INACK bit in the Mode Register (US_MR). If INACK is at 1, no error signal is driven on the I/O line even if a parity bit is detected, but the INACK bit is set in the Status Register (US_SR). The INACK bit can be cleared by writing the Control Register (US_CR) with the RSTNACK bit at 1.

Moreover, if INACK is reset, the erroneous received character is stored in the Receive Holding Register, as if no error occurred. However, the RXRDY bit does not raise.

Transmit Character Repetition

When the USART is transmitting a character and gets a NACK, it can automatically repeat the character before moving on to the next one. Repetition is enabled by writing the

MAX_ITERATION field in the Mode Register (US_MR) at a value higher than 0. Each character can be transmitted up to eight times; the first transmission plus seven repetitions.

If MAX_ITERATION does not equal zero, the USART repeats the character as many times as the value loaded in MAX_ITERATION.

When the USART repetition number reaches MAX_ITERATION, the ITERATION bit is set in the Channel Status Register (US_CSR). If the repetition of the character is acknowledged by the receiver, the repetitions are stopped and the iteration counter is cleared.

The ITERATION bit in US_CSR can be cleared by writing the Control Register with the RSIT bit at 1.

Disable Successive Receive NACK

The receiver can limit the number of successive NACKs sent back to the remote transmitter. This is programmed by setting the bit DSNACK in the Mode Register (US_MR). The maximum number of NACK transmitted is programmed in the MAX_ITERATION field. As soon as MAX_ITERATION is reached, the character is considered as correct, an acknowledge is sent on the line and the ITERATION bit in the Channel Status Register is set.

30.6.4.3 Protocol T = 1

When operating in ISO7816 protocol T = 1, the transmission is similar to an asynchronous format with only one stop bit. The parity is generated when transmitting and checked when receiving. Parity error detection sets the PARE bit in the Channel Status Register (US_CSR).

30.6.5 IrDA Mode

The USART features an IrDA mode supplying half-duplex point-to-point wireless communication. It embeds the modulator and demodulator which allows a glueless connection to the infrared transceivers, as shown in [Figure 30-22](#). The modulator and demodulator are compliant with the IrDA specification version 1.1 and support data transfer speeds ranging from 2,4 Kbps to 115,2 Kbps.

The USART IrDA mode is enabled by setting the USART_MODE field in the Mode Register (US_MR) to the value 0x8. The IrDA Filter Register (US_IF) allows configuring the demodulator filter. The USART transmitter and receiver operate in a normal asynchronous mode and all parameters are accessible. Note that the modulator and the demodulator are activated.

Figure 30-22. Connection to IrDA Transceivers

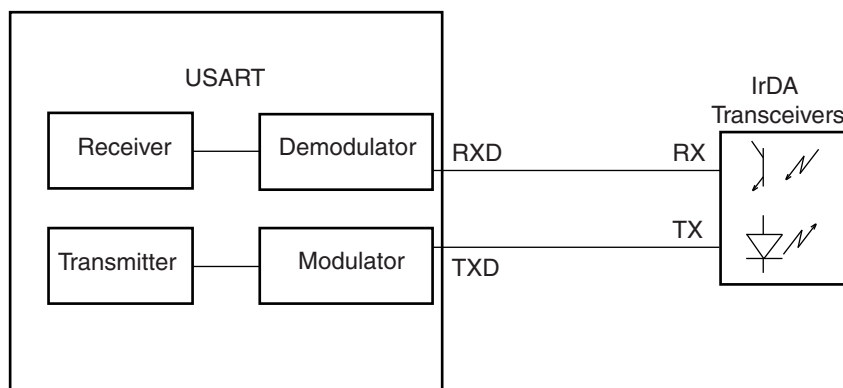

The receiver and the transmitter must be enabled or disabled according to the direction of the transmission to be managed.

30.6.5.1 IrDA Modulation

For baud rates up to and including 115.2 Kbits/sec, the RZI modulation scheme is used. “0” is represented by a light pulse of 3/16th of a bit time. Some examples of signal pulse duration are shown in [Table 30-9](#).

Table 30-9. IrDA Pulse Duration

Baud Rate	Pulse Duration (3/16)
2.4 Kb/s	78.13 μ s
9.6 Kb/s	19.53 μ s
19.2 Kb/s	9.77 μ s
38.4 Kb/s	4.88 μ s
57.6 Kb/s	3.26 μ s
115.2 Kb/s	1.63 μ s

[Figure 30-23](#) shows an example of character transmission.

Figure 30-23. IrDA Modulation

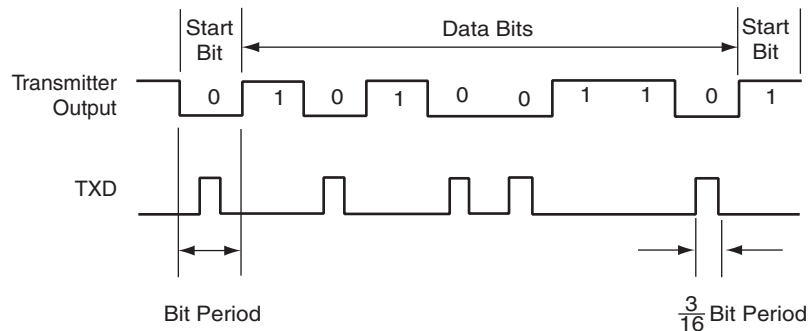

30.6.5.2 IrDA Baud Rate

[Table 30-10](#) gives some examples of CD values, baud rate error and pulse duration. Note that the requirement on the maximum acceptable error of +/- 1.87% must be met.

Table 30-10. IrDA Baud Rate Error

Peripheral Clock	Baud rate	CD	Baud rate Error	Pulse time
3 686 400	115 200	2	0.00%	1.63
20 000 000	115 200	11	1.38%	1.63
32 768 000	115 200	18	1.25%	1.63
40 000 000	115 200	22	1.38%	1.63
3 686 400	57 600	4	0.00%	3.26
20 000 000	57 600	22	1.38%	3.26
32 768 000	57 600	36	1.25%	3.26

Table 30-10. IrDA Baud Rate Error

Peripheral Clock	Baud rate	CD	Baud rate Error	Pulse time
40 000 000	57 600	43	0.93%	3.26
3 686 400	38 400	6	0.00%	4.88
20 000 000	38 400	33	1.38%	4.88
32 768 000	38 400	53	0.63%	4.88
40 000 000	38 400	65	0.16%	4.88
3 686 400	19 200	12	0.00%	9.77
20 000 000	19 200	65	0.16%	9.77
32 768 000	19 200	107	0.31%	9.77
40 000 000	19 200	130	0.16%	9.77
3 686 400	9 600	24	0.00%	19.53
20 000 000	9 600	130	0.16%	19.53
32 768 000	9 600	213	0.16%	19.53
40 000 000	9 600	260	0.16%	19.53
3 686 400	2 400	96	0.00%	78.13
20 000 000	2 400	521	0.03%	78.13
32 768 000	2 400	853	0.04%	78.13

30.6.5.3 IrDA Demodulator

The demodulator is based on the IrDA Receive filter comprised of an 8-bit down counter which is loaded with the value programmed in US_IF. When a falling edge is detected on the RXD pin, the Filter Counter starts counting down at the Master Clock (MCK) speed. If a rising edge is detected on the RXD pin, the counter stops and is reloaded with US_IF. If no rising edge is detected when the counter reaches 0, the input of the receiver is driven low during one bit time.

Figure 30-24 illustrates the operations of the IrDA demodulator.

Figure 30-24. IrDA Demodulator Operations

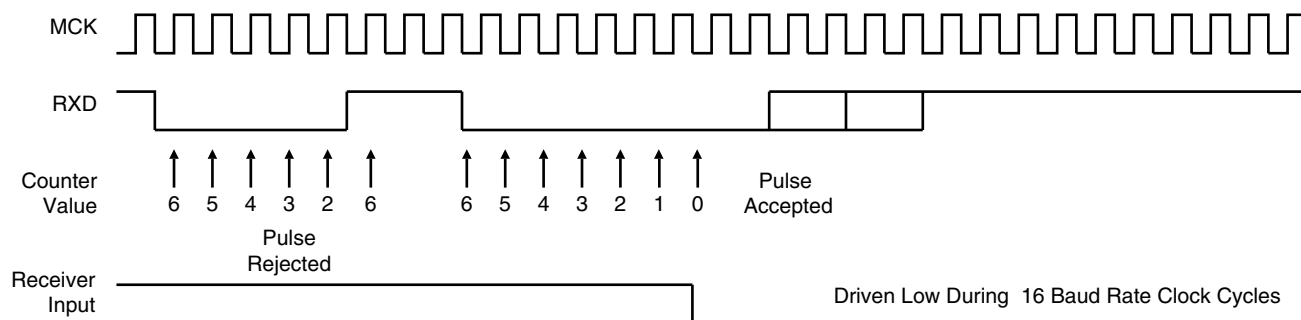

As the IrDA mode uses the same logic as the ISO7816, note that the FI_DI_RATIO field in US_FIDI must be set to a value higher than 0 in order to assure IrDA communications operate correctly.

30.6.6 RS485 Mode

The USART features the RS485 mode to enable line driver control. While operating in RS485 mode, the USART behaves as though in asynchronous or synchronous mode and configuration of all the parameters are possible. The difference is that the RTS pin is driven high when the transmitter is operating. The behavior of the RTS pin is controlled by the TXEMPTY bit. A typical connection of the USART to an RS485 bus is shown in [Figure 30-25](#).

Figure 30-25. Typical Connection to an RS485 bus.

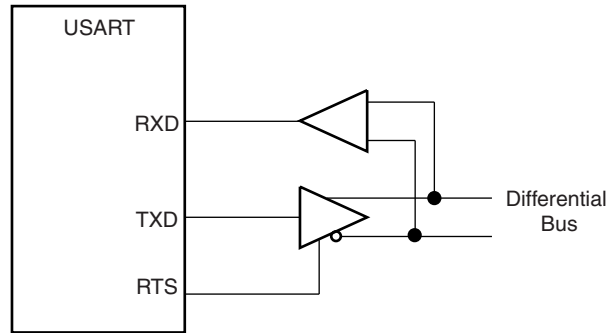

The USART is set in RS485 mode by programming the USART_MODE field in the Mode Register (US_MR) to the value 0x1.

The RTS pin is at a level inverse of the TXEMPTY bit. Significantly, the RTS pin remains high when a timeguard is programmed so that the line can remain driven after the last character completion. [Figure 30-26](#) gives an example of the RTS waveform during a character transmission when the timeguard is enabled.

Figure 30-26. Example of RTS Drive with Timeguard

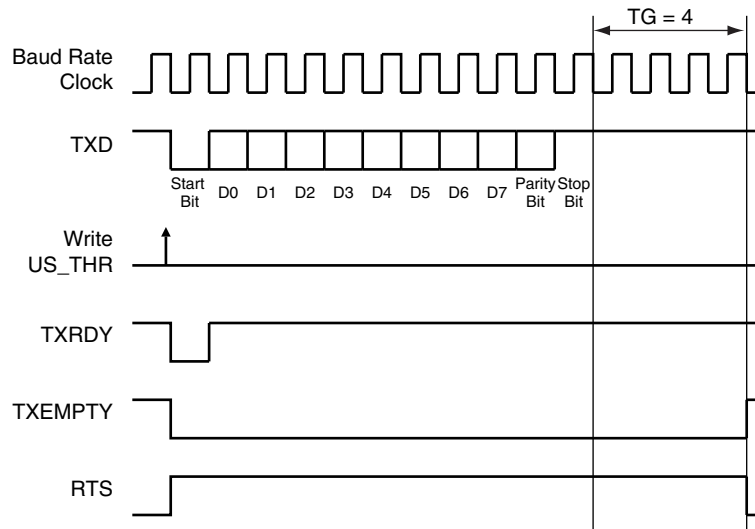

30.6.7 Modem Mode

The USART features modem mode, which enables control of the signals: DTR (Data Terminal Ready), DSR (Data Set Ready), RTS (Request to Send), CTS (Clear to Send), DCD (Data Carrier Detect) and RI (Ring Indicator). While operating in modem mode, the USART behaves as a

DTE (Data Terminal Equipment) as it drives DTR and RTS and can detect level change on DSR, DCD, CTS and RI.

Setting the USART in modem mode is performed by writing the USART_MODE field in the Mode Register (US_MR) to the value 0x3. While operating in modem mode the USART behaves as though in asynchronous mode and all the parameter configurations are available.

Table 30-11 gives the correspondence of the USART signals with modem connection standards.

Table 30-11. Circuit References

USART pin	V24	CCITT	Direction
TXD	2	103	From terminal to modem
RTS	4	105	From terminal to modem
DTR	20	108.2	From terminal to modem
RXD	3	104	From modem to terminal
CTS	5	106	From terminal to modem
DSR	6	107	From terminal to modem
DCD	8	109	From terminal to modem
RI	22	125	From terminal to modem

The control of the RTS and DTR output pins is performed by writing the Control Register (US_CR) with the RTSDIS, RTSEN, DTRDIS and DTREN bits respectively at 1. The disable command forces the corresponding pin to its inactive level, i.e. high. The enable commands force the corresponding pin to its active level, i.e. low.

The level changes are detected on the RI, DSR, DCD and CTS pins. If an input change is detected, the RIIC, DSRIC, DCDIC and CTSIC bits in the Channel Status Register (US_CSR) are set respectively and can trigger an interrupt. The status is automatically cleared when US_CSR is read. Furthermore, the CTS automatically disables the transmitter when it is detected at its inactive state. If a character is being transmitted when the CTS rises, the character transmission is completed before the transmitter is actually disabled.

30.6.8 Test Modes

The USART can be programmed to operate in three different test modes. The internal loopback capability allows on-board diagnostics. In the loopback mode the USART interface pins are disconnected or not and reconfigured for loopback internally or externally.

30.6.8.1 Normal Mode

As a reminder, the normal mode simply connects the RXD pin on the receiver input and the transmitter output on the TXD pin.

Figure 30-27. Normal Mode Configuration

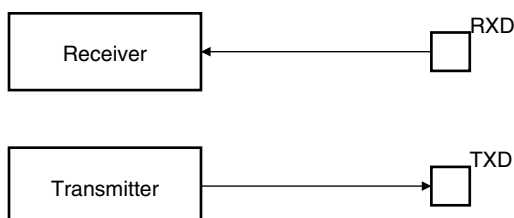

30.6.8.2 Automatic Echo

Automatic echo mode allows bit-by-bit retransmission. When a bit is received on the RXD pin, it is sent to the TXD pin, as shown in [Figure 30-28](#). Programming the transmitter has no effect on the TXD pin. The RXD pin is still connected to the receiver input, thus the receiver remains active.

Figure 30-28. Automatic Echo

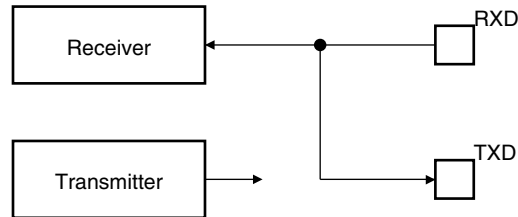

30.6.8.3 Local Loopback

The local loopback mode connects the output of the transmitter directly to the input of the receiver, as shown in [Figure 30-29](#). The TXD and RXD pins are not used. The RXD pin has no effect on the receiver and the TXD pin is continuously driven high, as in idle state.

Figure 30-29. Local Loopback

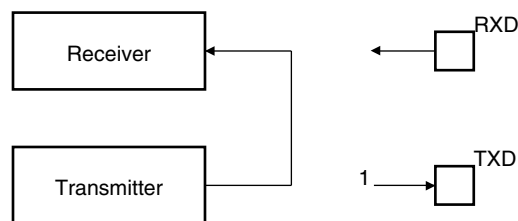

30.6.8.4 Remote Loopback

Remote loopback mode directly connects the RXD pin to the TXD pin, as shown in [Figure 30-30](#). The transmitter and the receiver are disabled and have no effect. This mode allows bit-by-bit retransmission.

Figure 30-30. Remote Loopback

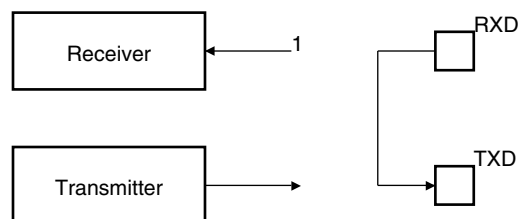

30.7 USART User Interface

Table 30-12. USART Memory Map

Offset	Register	Name	Access	Reset State
0x0000	Control Register	US_CR	Write-only	–
0x0004	Mode Register	US_MR	Read/Write	–
0x0008	Interrupt Enable Register	US_IER	Write-only	–
0x000C	Interrupt Disable Register	US_IDR	Write-only	–
0x0010	Interrupt Mask Register	US_IMR	Read-only	0x0
0x0014	Channel Status Register	US_CSR	Read-only	–
0x0018	Receiver Holding Register	US_RHR	Read-only	0x0
0x001C	Transmitter Holding Register	US_THR	Write-only	–
0x0020	Baud Rate Generator Register	US_BRGR	Read/Write	0x0
0x0024	Receiver Time-out Register	US_RTOR	Read/Write	0x0
0x0028	Transmitter Timeguard Register	US_TTGR	Read/Write	0x0
0x2C to 0x3C	Reserved	–	–	–
0x0040	FI DI Ratio Register	US_FIDI	Read/Write	0x174
0x0044	Number of Errors Register	US_NER	Read-only	–
0x0048	Reserved	–	–	–
0x004C	IrDA Filter Register	US_IF	Read/Write	0x0
0x5C to 0xFC	Reserved	–	–	–
0x100 to 0x128	Reserved for PDC Registers	–	–	–

30.7.1 USART Control Register

Name: US_CR

Access Type: Write-only

31	30	29	28	27	26	25	24
–	–	–	–	–	–	–	–
23	22	21	20	19	18	17	16
–	–	–	–	RTSDIS	RTSEN	DTRDIS	DTREN
15	14	13	12	11	10	9	8
RETTO	RSTNACK	RSTIT	SENDA	STTTO	STPBRK	STTBRK	RSTSTA
7	6	5	4	3	2	1	0
TXDIS	TXEN	RXDIS	RXEN	RSTTX	RSTRX	–	–

- **RSTRX: Reset Receiver**

0 = No effect.

1 = Resets the receiver.

- **RSTTX: Reset Transmitter**

0 = No effect.

1 = Resets the transmitter.

- **RXEN: Receiver Enable**

0 = No effect.

1 = Enables the receiver, if RXDIS is 0.

- **RXDIS: Receiver Disable**

0 = No effect.

1 = Disables the receiver.

- **TXEN: Transmitter Enable**

0 = No effect.

1 = Enables the transmitter if TXDIS is 0.

- **TXDIS: Transmitter Disable**

0 = No effect.

1 = Disables the transmitter.

- **RSTSTA: Reset Status Bits**

0 = No effect.

1 = Resets the status bits PARE, FRAME, OVRE and RXBRK in the US_CSR.

- **STTBRK: Start Break**

0 = No effect.

1 = Starts transmission of a break after the characters present in US_THR and the Transmit Shift Register have been transmitted. No effect if a break is already being transmitted.

- **STPBRK: Stop Break**

0 = No effect.

1 = Stops transmission of the break after a minimum of one character length and transmits a high level during 12-bit periods. No effect if no break is being transmitted.

- **STTTO: Start Time-out**

0 = No effect

1 = Starts waiting for a character before clocking the time-out counter.

- **SENDA: Send Address**

0 = No effect.

1 = In Multi-drop Mode only, the next character written to the US_THR is sent with the address bit set.

- **RSTIT: Reset Iterations**

0 = No effect.

1 = Resets ITERATION in US_CSR. No effect if the ISO7816 is not enabled.

- **RSTNACK: Reset Non Acknowledge**

0 = No effect

1 = Resets NACK in US_CSR.

- **RETTO: Rearm Time-out**

0 = No effect

1 = Restart Time-out

- **DTREN: Data Terminal Ready Enable**

0 = No effect.

1 = Drives the pin DTR at 0.

- **DTRDIS: Data Terminal Ready Disable**

0 = No effect.

1 = Drives the pin DTR to 1.

- **RTSEN: Request to Send Enable**

0 = No effect.

1 = Drives the pin RTS to 0.

- **RTSDIS: Request to Send Disable**

0 = No effect.





1 = Drives the pin RTS to 1.

30.7.2 USART Mode Register

Name: US_MR

Access Type: Read/Write

31	30	29	28	27	26	25	24
-	-	-	FILTER	-	MAX_ITERATION		
23	22	21	20	19	18	17	16
-	-	DSNACK	INACK	OVER	CLKO	MODE9	MSBF
15	14	13	12	11	10	9	8
CHMODE		NBSTOP		PAR			SYNC
7	6	5	4	3	2	1	0
CHRL		USCLKS		USART_MODE			

• USART_MODE

USART_MODE				Mode of the USART
0	0	0	0	Normal
0	0	0	1	RS485
0	0	1	0	Hardware Handshaking
0	0	1	1	Modem
0	1	0	0	ISO7816 Protocol: T = 0
0	1	0	1	Reserved
0	1	1	0	ISO7816 Protocol: T = 1
0	1	1	1	Reserved
1	0	0	0	IrDA
1	1	x	x	Reserved

• USCLKS: Clock Selection

USCLKS		Selected Clock
0	0	MCK
0	1	MCK / DIV
1	0	Reserved
1	1	SCK

- **CHRL: Character Length.**

CHRL		Character Length
0	0	5 bits
0	1	6 bits
1	0	7 bits
1	1	8 bits

- **SYNC: Synchronous Mode Select**

0 = USART operates in Asynchronous Mode.

1 = USART operates in Synchronous Mode

- **PAR: Parity Type**

PAR			Parity Type
0	0	0	Even parity
0	0	1	Odd parity
0	1	0	Parity forced to 0 (Space)
0	1	1	Parity forced to 1 (Mark)
1	0	x	No parity
1	1	x	Multi-drop mode

- **NBSTOP: Number of Stop Bits**

NBSTOP		Asynchronous (SYNC = 0)	Synchronous (SYNC = 1)
0	0	1 stop bit	1 stop bit
0	1	1.5 stop bits	Reserved
1	0	2 stop bits	2 stop bits
1	1	Reserved	Reserved

- **CHMODE: Channel Mode**

CHMODE		Mode Description
0	0	Normal Mode
0	1	Automatic Echo. Receiver input is connected to the TXD pin.
1	0	Local Loopback. Transmitter output is connected to the Receiver Input..
1	1	Remote Loopback. RXD pin is internally connected to the TXD pin.

- **MSBF: Bit Order**

0 = Least Significant Bit is sent/received first.

1 = Most Significant Bit is sent/received first.

- **MODE9: 9-bit Character Length**

0 = CHRL defines character length.

1 = 9-bit character length.

- **CKLO: Clock Output Select**

0 = The USART does not drive the SCK pin.

1 = The USART drives the SCK pin if USCLKS does not select the external clock SCK.

- **OVER: Oversampling Mode**

0 = 16x Oversampling.

1 = 8x Oversampling.

- **INACK: Inhibit Non Acknowledge**

0 = The NACK is generated.

1 = The NACK is not generated.

- **DSNACK: Disable Successive NACK**

0 = NACK is sent on the ISO line as soon as a parity error occurs in the received character (unless INACK is set).

1 = Successive parity errors are counted up to the value specified in the MAX_ITERATION field. These parity errors generate a NACK on the ISO line. As soon as this value is reached, no additional NACK is sent on the ISO line. The flag ITERATION is asserted.

- **MAX_ITERATION**

Defines the maximum number of iterations in mode ISO7816, protocol T = 0.

- **FILTER: Infrared Receive Line Filter**

0 = The USART does not filter the receive line.

1 = The USART filters the receive line using a three-sample filter (1/16-bit clock) (2 over 3 majority).

30.7.3 USART Interrupt Enable Register

Name: US_IER

Access Type: Write-only

31	30	29	28	27	26	25	24
–	–	–	–	–	–	–	–
23	22	21	20	19	18	17	16
–	–	–	–	CTSIC	DCDIC	DSRIC	RIIC
15	14	13	12	11	10	9	8
–	–	NACK	RXBUFF	TXBUFE	ITERATION	TXEMPTY	TIMEOUT
7	6	5	4	3	2	1	0
PARE	FRAME	OVRE	ENDTX	ENDRX	RXBRK	TXRDY	RXRDY

- **RXRDY: RXRDY Interrupt Enable**
- **TXRDY: TXRDY Interrupt Enable**
- **RXBRK: Receiver Break Interrupt Enable**
- **ENDRX: End of Receive Transfer Interrupt Enable**
- **ENDTX: End of Transmit Interrupt Enable**
- **OVRE: Overrun Error Interrupt Enable**
- **FRAME: Framing Error Interrupt Enable**
- **PARE: Parity Error Interrupt Enable**
- **TIMEOUT: Time-out Interrupt Enable**
- **TXEMPTY: TXEMPTY Interrupt Enable**
- **ITERATION: Iteration Interrupt Enable**
- **TXBUFE: Buffer Empty Interrupt Enable**
- **RXBUFF: Buffer Full Interrupt Enable**
- **NACK: Non Acknowledge Interrupt Enable**
- **RIIC: Ring Indicator Input Change Enable**
- **DSRIC: Data Set Ready Input Change Enable**
- **DCDIC: Data Carrier Detect Input Change Interrupt Enable**
- **CTSIC: Clear to Send Input Change Interrupt Enable**

0 = No effect.

1 = Enables the corresponding interrupt.

30.7.4 USART Interrupt Disable Register

Name: US_IDR

Access Type: Write-only

31	30	29	28	27	26	25	24
–	–	–	–	–	–	–	–
23	22	21	20	19	18	17	16
–	–	–	–	CTSIC	DCDIC	DSRIC	RIIC
15	14	13	12	11	10	9	8
–	–	NACK	RXBUFF	TXBUFE	ITERATION	TXEMPTY	TIMEOUT
7	6	5	4	3	2	1	0
PARE	FRAME	OVRE	ENDTX	ENDRX	RXBRK	TXRDY	RXRDY

- **RXRDY: RXRDY Interrupt Disable**
- **TXRDY: TXRDY Interrupt Disable**
- **RXBRK: Receiver Break Interrupt Disable**
- **ENDRX: End of Receive Transfer Interrupt Disable**
- **ENDTX: End of Transmit Interrupt Disable**
- **OVRE: Overrun Error Interrupt Disable**
- **FRAME: Framing Error Interrupt Disable**
- **PARE: Parity Error Interrupt Disable**
- **TIMEOUT: Time-out Interrupt Disable**
- **TXEMPTY: TXEMPTY Interrupt Disable**
- **ITERATION: Iteration Interrupt Disable**
- **TXBUFE: Buffer Empty Interrupt Disable**
- **RXBUFF: Buffer Full Interrupt Disable**
- **NACK: Non Acknowledge Interrupt Disable**
- **RIIC: Ring Indicator Input Change Disable**
- **DSRIC: Data Set Ready Input Change Disable**
- **DCDIC: Data Carrier Detect Input Change Interrupt Disable**
- **CTSIC: Clear to Send Input Change Interrupt Disable**

0 = No effect.

1 = Disables the corresponding interrupt.



30.7.5 USART Interrupt Mask Register

Name: US_IMR

Access Type: Read-only

31	30	29	28	27	26	25	24
–	–	–	–	–	–	–	–
23	22	21	20	19	18	17	16
–	–	–	–	CTSIC	DCDIC	DSRIC	RIIC
15	14	13	12	11	10	9	8
–	–	NACK	RXBUFF	TXBUFE	ITERATION	TXEMPTY	TIMEOUT
7	6	5	4	3	2	1	0
PARE	FRAME	OVRE	ENDTX	ENDRX	RXBRK	TXRDY	RXRDY

- **RXRDY: RXRDY Interrupt Mask**
- **TXRDY: TXRDY Interrupt Mask**
- **RXBRK: Receiver Break Interrupt Mask**
- **ENDRX: End of Receive Transfer Interrupt Mask**
- **ENDTX: End of Transmit Interrupt Mask**
- **OVRE: Overrun Error Interrupt Mask**
- **FRAME: Framing Error Interrupt Mask**
- **PARE: Parity Error Interrupt Mask**
- **TIMEOUT: Time-out Interrupt Mask**
- **TXEMPTY: TXEMPTY Interrupt Mask**
- **ITERATION: Iteration Interrupt Mask**
- **TXBUFE: Buffer Empty Interrupt Mask**
- **RXBUFF: Buffer Full Interrupt Mask**
- **NACK: Non Acknowledge Interrupt Mask**
- **RIIC: Ring Indicator Input Change Mask**
- **DSRIC: Data Set Ready Input Change Mask**
- **DCDIC: Data Carrier Detect Input Change Interrupt Mask**
- **CTSIC: Clear to Send Input Change Interrupt Mask**

0 = The corresponding interrupt is disabled.

1 = The corresponding interrupt is enabled.

30.7.6 USART Channel Status Register

Name: US_CSR

Access Type: Read-only

31	30	29	28	27	26	25	24
–	–	–	–	–	–	–	–
23	22	21	20	19	18	17	16
CTS	DCD	DSR	RI	CTSIC	DCDIC	DSRIC	RIIC
15	14	13	12	11	10	9	8
–	–	NACK	RXBUFF	TXBUFE	ITERATION	TXEMPTY	TIMEOUT
7	6	5	4	3	2	1	0
PARE	FRAME	OVRE	ENDTX	ENDRX	RXBRK	TXRDY	RXRDY

- **RXRDY: Receiver Ready**

0 = No complete character has been received since the last read of US_RHR or the receiver is disabled. If characters were being received when the receiver was disabled, RXRDY changes to 1 when the receiver is enabled.

1 = At least one complete character has been received and US_RHR has not yet been read.

- **TXRDY: Transmitter Ready**

0 = A character is in the US_THR waiting to be transferred to the Transmit Shift Register, or an STTBRK command has been requested, or the transmitter is disabled. As soon as the transmitter is enabled, TXRDY becomes 1.

1 = There is no character in the US_THR.

- **RXBRK: Break Received/End of Break**

0 = No Break received or End of Break detected since the last RSTSTA.

1 = Break Received or End of Break detected since the last RSTSTA.

- **ENDRX: End of Receiver Transfer**

0 = The End of Transfer signal from the Receive PDC channel is inactive.

1 = The End of Transfer signal from the Receive PDC channel is active.

- **ENDTX: End of Transmitter Transfer**

0 = The End of Transfer signal from the Transmit PDC channel is inactive.

1 = The End of Transfer signal from the Transmit PDC channel is active.

- **OVRE: Overrun Error**

0 = No overrun error has occurred since the last RSTSTA.

1 = At least one overrun error has occurred since the last RSTSTA.

- **FRAME: Framing Error**

0 = No stop bit has been detected low since the last RSTSTA.

1 = At least one stop bit has been detected low since the last RSTSTA.

- **PARE: Parity Error**

0 = No parity error has been detected since the last RSTSTA.

1 = At least one parity error has been detected since the last RSTSTA.

- **TIMEOUT: Receiver Time-out**

0 = There has not been a time-out since the last Start Time-out command or the Time-out Register is 0.

1 = There has been a time-out since the last Start Time-out command.

- **TXEMPTY: Transmitter Empty**

0 = There are characters in either US_THR or the Transmit Shift Register, or the transmitter is disabled.

1 = There is at least one character in either US_THR or the Transmit Shift Register.

- **ITERATION: Max number of Repetitions Reached**

0 = Maximum number of repetitions has not been reached since the last RSIT.

1 = Maximum number of repetitions has been reached since the last RSIT.

- **TXBUFE: Transmission Buffer Empty**

0 = The signal Buffer Empty from the Transmit PDC channel is inactive.

1 = The signal Buffer Empty from the Transmit PDC channel is active.

- **RXBUFF: Reception Buffer Full**

0 = The signal Buffer Full from the Receive PDC channel is inactive.

1 = The signal Buffer Full from the Receive PDC channel is active.

- **NACK: Non Acknowledge**

0 = No Non Acknowledge has not been detected since the last RSTNACK.

1 = At least one Non Acknowledge has been detected since the last RSTNACK.

- **RIIC: Ring Indicator Input Change Flag**

0 = No input change has been detected on the RI pin since the last read of US_CSR.

1 = At least one input change has been detected on the RI pin since the last read of US_CSR.

- **DSRIC: Data Set Ready Input Change Flag**

0 = No input change has been detected on the DSR pin since the last read of US_CSR.

1 = At least one input change has been detected on the DSR pin since the last read of US_CSR.

- **DCDIC: Data Carrier Detect Input Change Flag**

0 = No input change has been detected on the DCD pin since the last read of US_CSR.

1 = At least one input change has been detected on the DCD pin since the last read of US_CSR.

- **CTSIC: Clear to Send Input Change Flag**

0 = No input change has been detected on the CTS pin since the last read of US_CSR.

1 = At least one input change has been detected on the CTS pin since the last read of US_CSR.

- **RI: Image of RI Input**

0 = RI is at 0.

1 = RI is at 1.

- **DSR: Image of DSR Input**

0 = DSR is at 0

1 = DSR is at 1.

- **DCD: Image of DCD Input**

0 = DCD is at 0.

1 = DCD is at 1.

- **CTS: Image of CTS Input**

0 = CTS is at 0.

1 = CTS is at 1.



30.7.7 USART Receive Holding Register

Name: US_RHR

Access Type: Read-only

31	30	29	28	27	26	25	24
–	–	–	–	–	–	–	–
23	22	21	20	19	18	17	16
–	–	–	–	–	–	–	–
15	14	13	12	11	10	9	8
–	–	–	–	–	–	–	RXCHR
7	6	5	4	3	2	1	0
RXCHR							

• **RXCHR: Received Character**

Last character received if RXRDY is set.

30.7.8 USART Transmit Holding Register

Name: US_THR

Access Type: Write-only

31	30	29	28	27	26	25	24
–	–	–	–	–	–	–	–
23	22	21	20	19	18	17	16
–	–	–	–	–	–	–	–
15	14	13	12	11	10	9	8
–	–	–	–	–	–	–	TXCHR
7	6	5	4	3	2	1	0
TXCHR							

• **TXCHR: Character to be Transmitted**

Next character to be transmitted after the current character if TXRDY is not set.

30.7.9 USART Baud Rate Generator Register

Name: US_BRGR

Access Type: Read/Write

31	30	29	28	27	26	25	24
–	–	–	–	–	–	–	–
23	22	21	20	19	18	17	16
–	–	–	–	–	–	–	–
15	14	13	12	11	10	9	8
CD							
7	6	5	4	3	2	1	0
CD							

• CD: Clock Divider

CD	USART_MODE ≠ ISO7816			USART_MODE = ISO7816
	SYNC = 0		SYNC = 1	
	OVER = 0	OVER = 1		
0	Baud Rate Clock Disabled			
1 to 65535	Baud Rate = Selected Clock/16/CD	Baud Rate = Selected Clock/8/CD	Baud Rate = Selected Clock /CD	Baud Rate = Selected Clock/CD/FI_DI_RATIO

30.7.10 USART Receiver Time-out Register

Name: US_RTOR

Access Type: Read/Write

31	30	29	28	27	26	25	24
–	–	–	–	–	–	–	–
23	22	21	20	19	18	17	16
–	–	–	–	–	–	–	–
15	14	13	12	11	10	9	8
TO							
7	6	5	4	3	2	1	0
TO							

• TO: Time-out Value

0: The Receiver Time-out is disabled.

1 - 65535: The Receiver Time-out is enabled and the Time-out delay is TO x Bit Period.



30.7.11 USART Transmitter Timeguard Register

Name: US_TTGR

Access Type: Read/Write

31	30	29	28	27	26	25	24
-	-	-	-	-	-	-	-
23	22	21	20	19	18	17	16
-	-	-	-	-	-	-	-
15	14	13	12	11	10	9	8
-	-	-	-	-	-	-	-
7	6	5	4	3	2	1	0
TG							

• **TG: Timeguard Value**

0: The Transmitter Timeguard is disabled.

1 - 255: The Transmitter timeguard is enabled and the timeguard delay is TG x Bit Period.

30.7.12 USART FI DI RATIO Register

Name: US_FIDI

Access Type: Read/Write

Reset Value : 0x174

31	30	29	28	27	26	25	24
-	-	-	-	-	-	-	-
23	22	21	20	19	18	17	16
-	-	-	-	-	-	-	-
15	14	13	12	11	10	9	8
-	-	-	-	-	FI_DI_RATIO		
7	6	5	4	3	2	1	0
FI_DI_RATIO							

• **FI_DI_RATIO: FI Over DI Ratio Value**

0: If ISO7816 mode is selected, the Baud Rate Generator generates no signal.

1-2047: If ISO7816 mode is selected, the Baud Rate is the clock provided on SCK divided by FI_DI_RATIO.

30.7.13 USART Number of Errors Register

Name: US_NER

Access Type: Read-only

31	30	29	28	27	26	25	24
–	–	–	–	–	–	–	–
23	22	21	20	19	18	17	16
–	–	–	–	–	–	–	–
15	14	13	12	11	10	9	8
–	–	–	–	–	–	–	–
7	6	5	4	3	2	1	0
NB_ERRORS							

- **NB_ERRORS: Number of Errors**

Total number of errors that occurred during an ISO7816 transfer. This register automatically clears when read.

30.7.14 USART IrDA FILTER Register

Name: US_IF

Access Type: Read/Write

31	30	29	28	27	26	25	24
–	–	–	–	–	–	–	–
23	22	21	20	19	18	17	16
–	–	–	–	–	–	–	–
15	14	13	12	11	10	9	8
–	–	–	–	–	–	–	–
7	6	5	4	3	2	1	0
IRDA_FILTER							

- **IRDA_FILTER: IrDA Filter**

Sets the filter of the IrDA demodulator.

31. Serial Synchronous Controller (SSC)

31.1 Overview

The Atmel Synchronous Serial Controller (SSC) provides a synchronous communication link with external devices. It supports many serial synchronous communication protocols generally used in audio and telecom applications such as I2S, Short Frame Sync, Long Frame Sync, etc.

The SSC contains an independent receiver and transmitter and a common clock divider. The receiver and the transmitter each interface with three signals: the TD/RD signal for data, the TK/RK signal for the clock and the TF/RF signal for the Frame Sync. Transfers contain up to 16 data of up to 32 bits. they can be programmed to start automatically or on different events detected on the Frame Sync signal.

The SSC's high-level of programmability and its two dedicated PDC channels of up to 32 bits permit a continuous high bit rate data transfer without processor intervention.

Featuring connection to two PDC channels, the SSC permits interfacing with low processor overhead to the following:

- CODECs in master or slave mode
- DAC through dedicated serial interface, particularly I2S
- Magnetic card reader

Features of the SSC are:

- Provides Serial Synchronous Communication Links Used in Audio and Telecom Applications
- Contains an Independent Receiver and Transmitter and a Common Clock Divider
- Interfaced with Two PDC Channels (DMA Access) to Reduce Processor Overhead
- Offers a Configurable Frame Sync and Data Length
- Receiver and Transmitter can be Programmed to Start Automatically or on Detection of Different Event on the Frame Sync Signal
- Receiver and Transmitter Include a Data Signal, a Clock Signal and a Frame Synchronization Signal

31.2 Block Diagram

Figure 31-1. Block Diagram

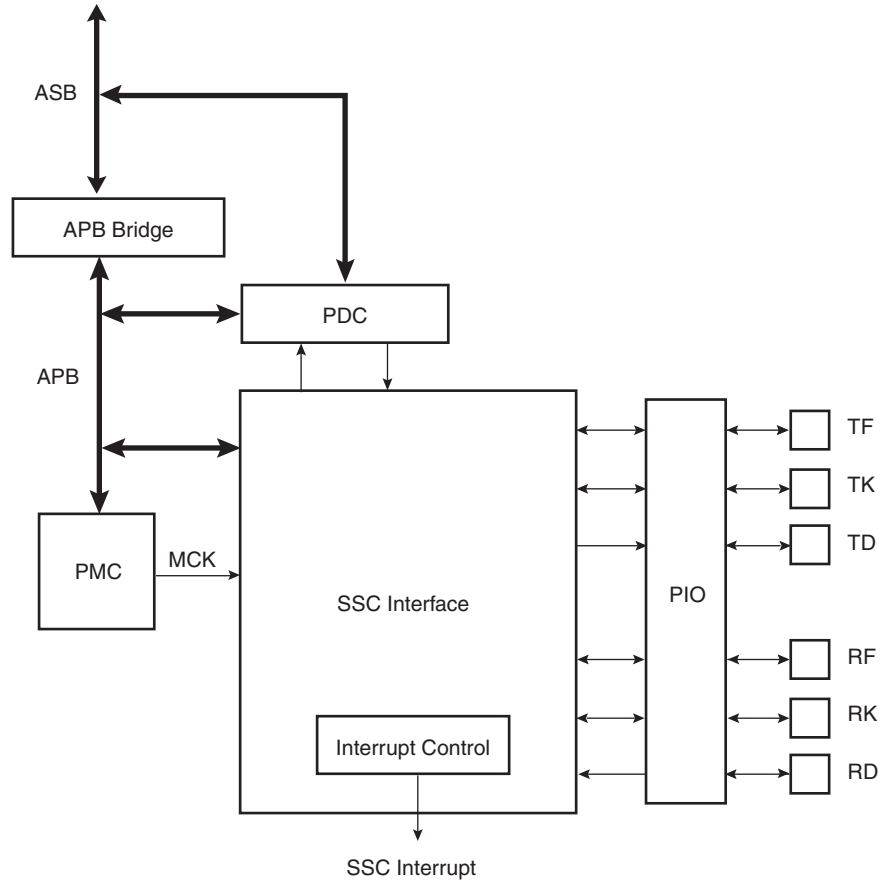

31.3 Application Block Diagram

Figure 31-2. Application Block Diagram

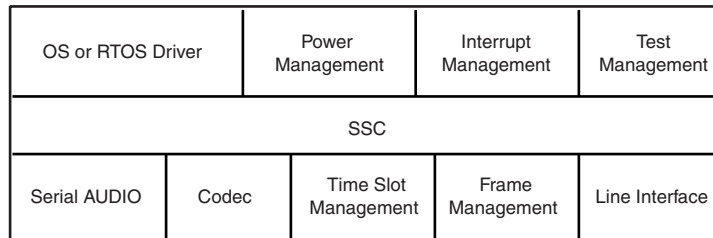

31.4 Pin Name List

Table 31-1. I/O Lines Description

Pin Name	Pin Description	Type
RF	Receiver Frame Synchro	Input/Output
RK	Receiver Clock	Input/Output
RD	Receiver Data	Input
TF	Transmitter Frame Synchro	Input/Output
TK	Transmitter Clock	Input/Output
TD	Transmitter Data	Output

31.5 Product Dependencies

31.5.1 I/O Lines

The pins used for interfacing the compliant external devices may be multiplexed with PIO lines.

Before using the SSC receiver, the PIO controller must be configured to dedicate the SSC receiver I/O lines to the SSC peripheral mode.

Before using the SSC transmitter, the PIO controller must be configured to dedicate the SSC transmitter I/O lines to the SSC peripheral mode.

31.5.2 Power Management

The SSC is not continuously clocked. The SSC interface may be clocked through the Power Management Controller (PMC), therefore the programmer must first configure the PMC to enable the SSC clock.

31.5.3 Interrupt

The SSC interface has an interrupt line connected to the Advanced Interrupt Controller (AIC). Handling interrupts requires programming the AIC before configuring the SSC.

All SSC interrupts can be enabled/disabled configuring the SSC Interrupt mask register. Each pending and unmasked SSC interrupt will assert the SSC interrupt line. The SSC interrupt service routine can get the interrupt origin by reading the SSC interrupt status register.

31.6 Functional Description

This chapter contains the functional description of the following: SSC Functional Block, Clock Management, Data format, Start, Transmitter, Receiver and Frame Sync.

The receiver and transmitter operate separately. However, they can work synchronously by programming the receiver to use the transmit clock and/or to start a data transfer when transmission starts. Alternatively, this can be done by programming the transmitter to use the receive clock and/or to start a data transfer when reception starts. The transmitter and the receiver can be programmed to operate with the clock signals provided on either the TK or RK pins. This allows the SSC to support many slave-mode data transfers. The maximum clock speed allowed on the TK and RK pins is the master clock divided by 2. Each level of the clock must be stable for at least two master clock periods.

Figure 31-3. SSC Functional Block Diagram

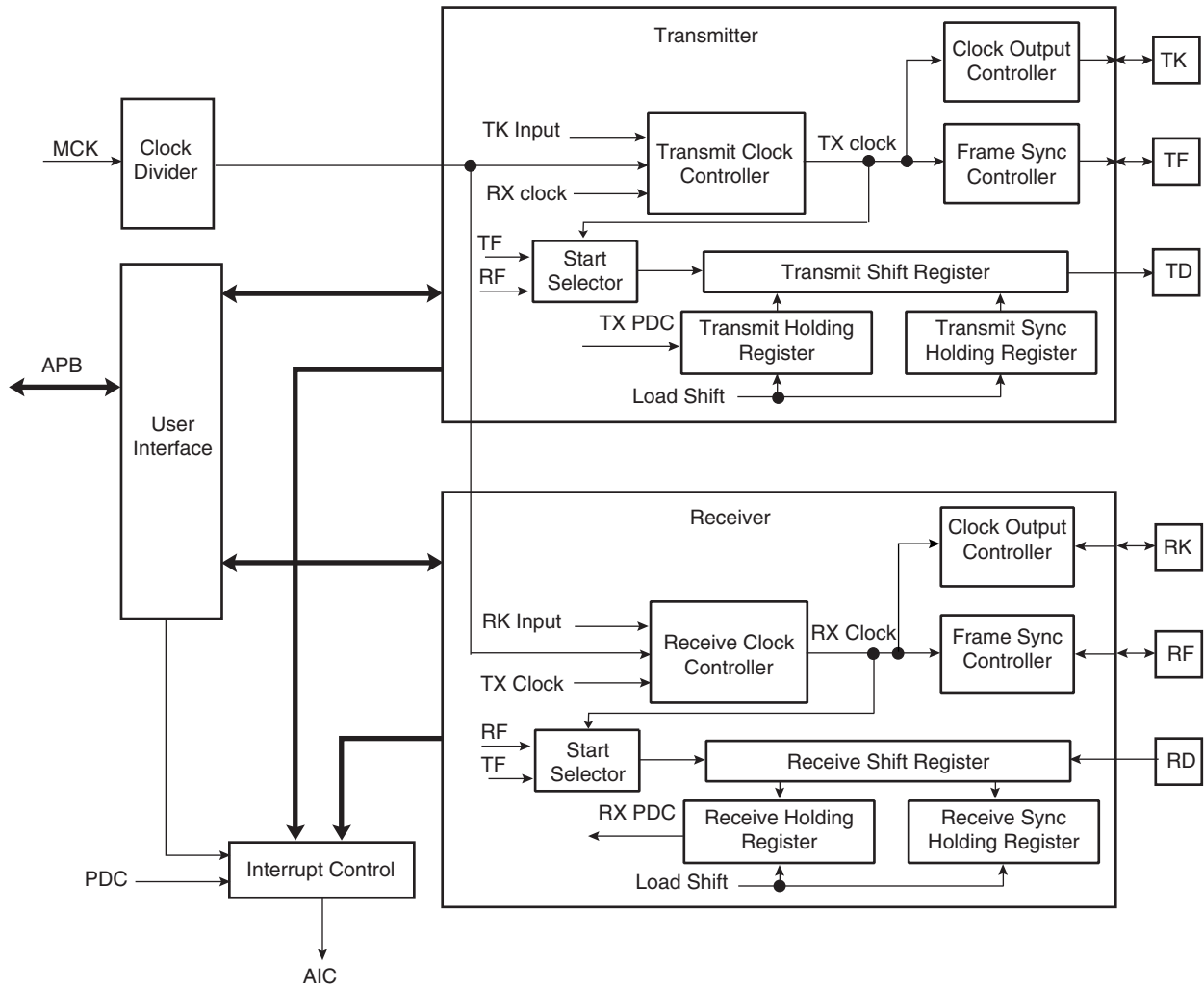

31.6.1 Clock Management

The transmitter clock can be generated by:

- an external clock received on the TK I/O pad
- the receiver clock
- the internal clock divider

The receiver clock can be generated by:

- an external clock received on the RK I/O pad
- the transmitter clock
- the internal clock divider

Furthermore, the transmitter block can generate an external clock on the TK I/O pad, and the receiver block can generate an external clock on the RK I/O pad.

This allows the SSC to support many Master and Slave-mode data transfers.

31.6.1.1 Clock Divider

Figure 31-4. Divided Clock Block Diagram

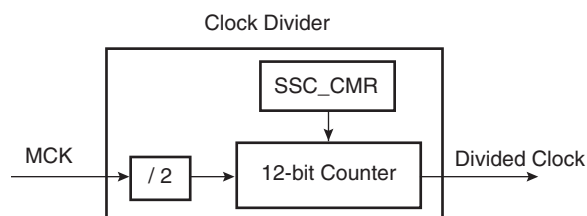

The Master Clock divider is determined by the 12-bit field DIV counter and comparator (so its maximal value is 4095) in the Clock Mode Register SSC_CMCR, allowing a Master Clock division by up to 8190. The Divided Clock is provided to both the Receiver and Transmitter. When this field is programmed to 0, the Clock Divider is not used and remains inactive.

When DIV is set to a value equal or greater to 1, the Divided Clock has a frequency of Master Clock divided by 2 times DIV. Each level of the Divided Clock has a duration of the Master Clock multiplied by DIV. This ensures a 50% duty cycle for the Divided Clock regardless if the DIV value is even or odd.

Figure 31-5. Divided Clock Generation

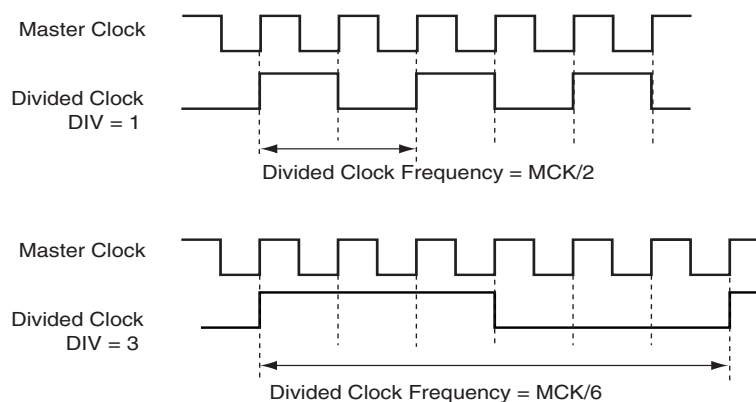

Table 31-2. Bit Rate

Maximum	Minimum
MCK / 2	MCK / 8190

31.6.1.2 Transmitter Clock Management

The transmitter clock is generated from the receiver clock or the divider clock or an external clock scanned on the TK I/O pad. The transmitter clock is selected by the CKS field in SSC_TCMR (Transmit Clock Mode Register). Transmit Clock can be inverted independently by the CKI bits in SSC_TCMR.

The transmitter can also drive the TK I/O pad continuously or be limited to the actual data transfer. The clock output is configured by the SSC_TCMR register. The Transmit Clock Inversion (CKI) bits have no effect on the clock outputs. Programming the TCMR register to select TK pin

(CKS field) and at the same time Continuous Transmit Clock (CKO field) might lead to unpredictable results.

Figure 31-6. Transmitter Clock Management

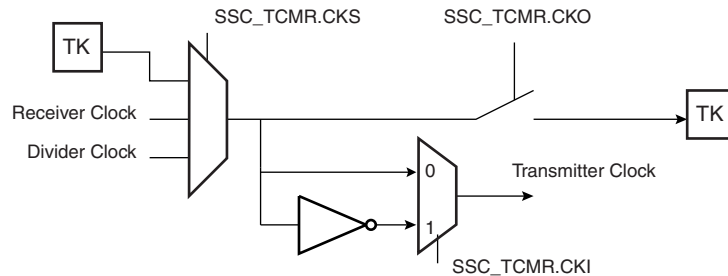

31.6.1.3 Receiver Clock Management

The receiver clock is generated from the transmitter clock or the divider clock or an external clock scanned on the RK I/O pad. The Receive Clock is selected by the CKS field in SSC_RCMR (Receive Clock Mode Register). Receive Clocks can be inverted independently by the CKI bits in SSC_RCMR.

The receiver can also drive the RK I/O pad continuously or be limited to the actual data transfer. The clock output is configured by the SSC_RCMR register. The Receive Clock Inversion (CKI) bits have no effect on the clock outputs. Programming the RCMR register to select RK pin (CKS field) and at the same time Continuous Receive Clock (CKO field) might lead to unpredictable results.

Figure 31-7. Receiver Clock Management

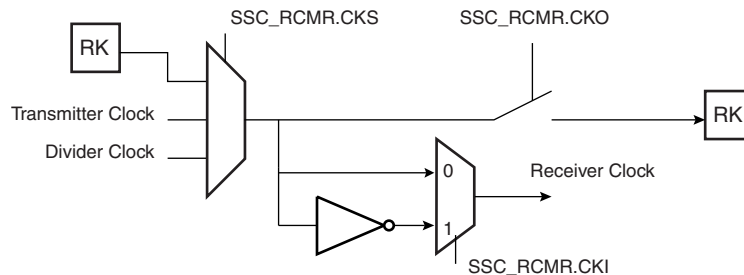

31.6.2 Transmitter Operations

A transmitted frame is triggered by a start event and can be followed by synchronization data before data transmission.

The start event is configured by setting the Transmit Clock Mode Register (SSC_TCMR). (See Section 31.6.4 "Start" on page 462.)

The frame synchronization is configured setting the Transmit Frame Mode Register (SSC_TFMR). (See Section 31.6.5 "Frame Sync" on page 463.)

To transmit data, the transmitter uses a shift register clocked by the transmitter clock signal and the start mode selected in the SSC_TCMR. Data is written by the application to the SSC_THR register then transferred to the shift register according to the data format selected.

When both the SSC_THR and the transmit shift register are empty, the status flag TXEMPTY is set in SSC_SR. When the Transmit Holding register is transferred in the Transmit shift register,

the status flag TXRDY is set in SSC_SR and additional data can be loaded in the holding register.

Figure 31-8. Transmitter Block Diagram

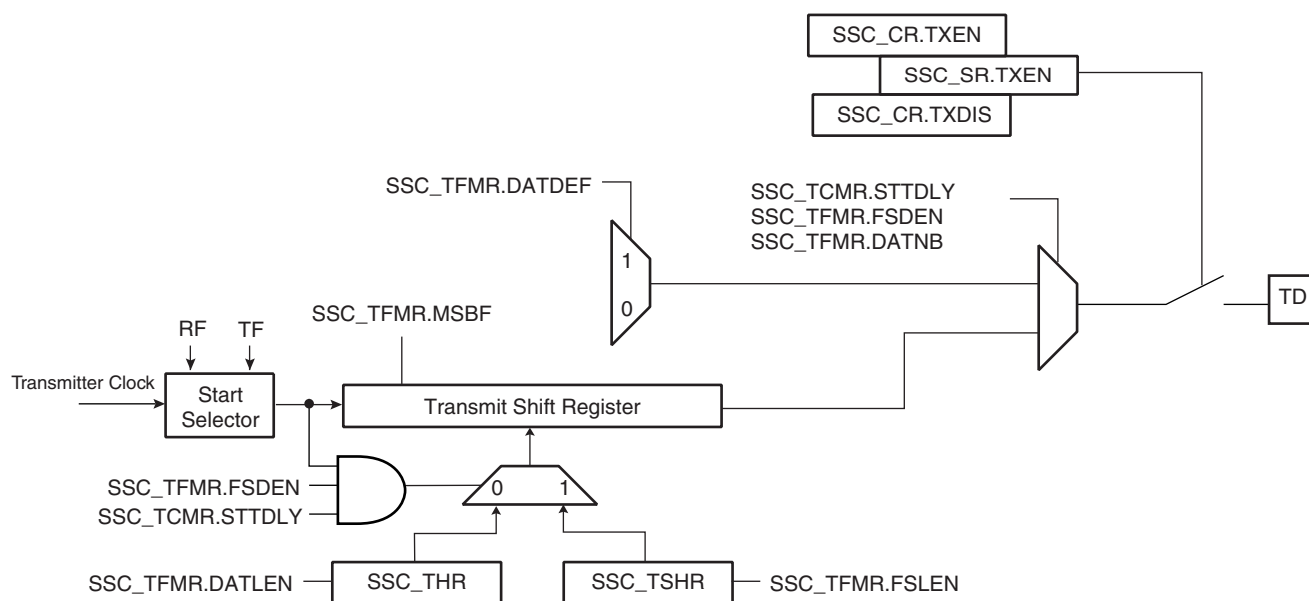

31.6.3 Receiver Operations

A received frame is triggered by a start event and can be followed by synchronization data before data transmission.

The start event is configured setting the Receive Clock Mode Register (SSC_RCMR). (See Section 31.6.4 "Start" on page 462.)

The frame synchronization is configured setting the Receive Frame Mode Register (SSC_RFMR). (See Section 31.6.5 "Frame Sync" on page 463.)

The receiver uses a shift register clocked by the receiver clock signal and the start mode selected in the SSC_RCMR. The data is transferred from the shift register in function of data format selected.

When the receiver shift register is full, the SSC transfers this data in the holding register, the status flag RXRDY is set in SSC_SR and the data can be read in the receiver holding register, if another transfer occurs before read the RHR register, the status flag OVERUN is set in SSC_SR and the receiver shift register is transferred in the RHR register.

Figure 31-9. Receiver Block Diagram

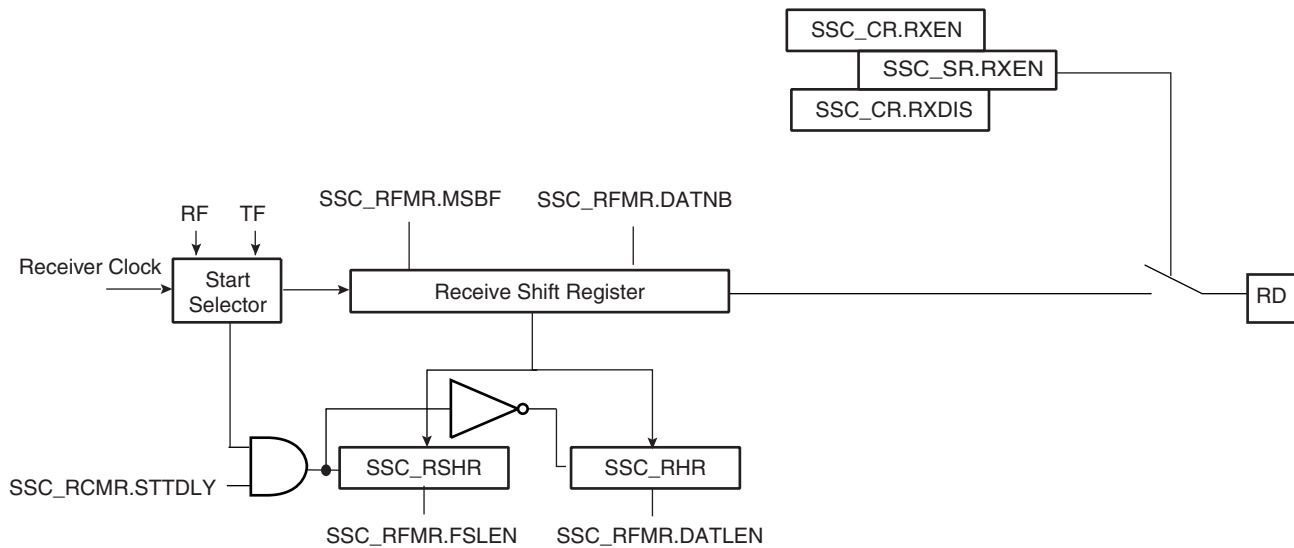

31.6.4 Start

The transmitter and receiver can both be programmed to start their operations when an event occurs, respectively in the Transmit Start Selection (START) field of SSC_TCMR and in the Receive Start Selection (START) field of SSC_RCMR.

Under the following conditions the start event is independently programmable:

- Continuous. In this case, the transmission starts as soon as a word is written in SSC_THR and the reception starts as soon as the Receiver is enabled.
- Synchronously with the transmitter/receiver
- On detection of a falling/rising edge on TK/RK
- On detection of a low level/high level on TK/RK
- On detection of a level change or an edge on TK/RK

A start can be programmed in the same manner on either side of the Transmit/Receive Clock Register (RCMR/TCMR). Thus, the start could be on TF (Transmit) or RF (Receive).

Detection on TF/RF input/output is done through the field FSOS of the Transmit / Receive Frame Mode Register (TFMR/RFMR).

Generating a Frame Sync signal is not possible without generating it on its related output.

Figure 31-10. Transmit Start Mode

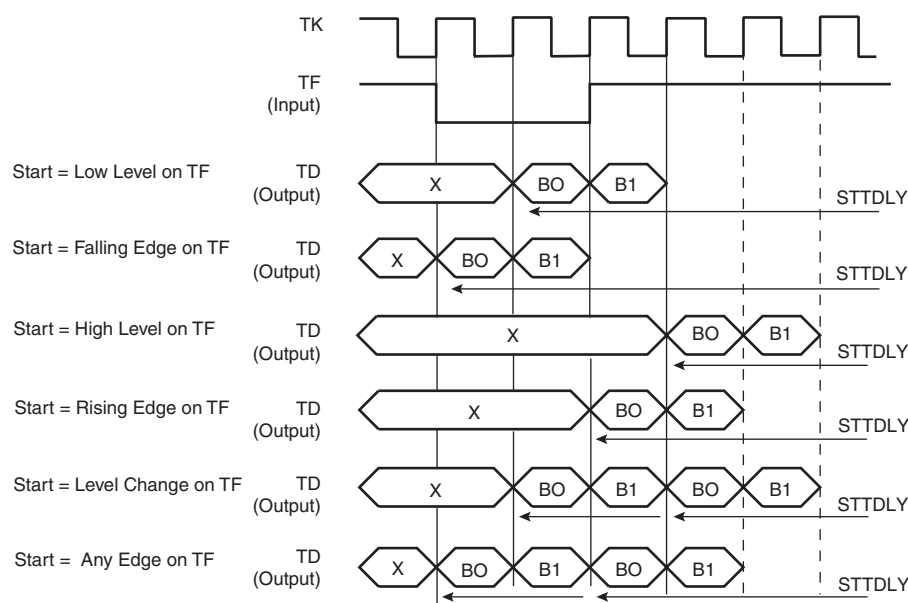
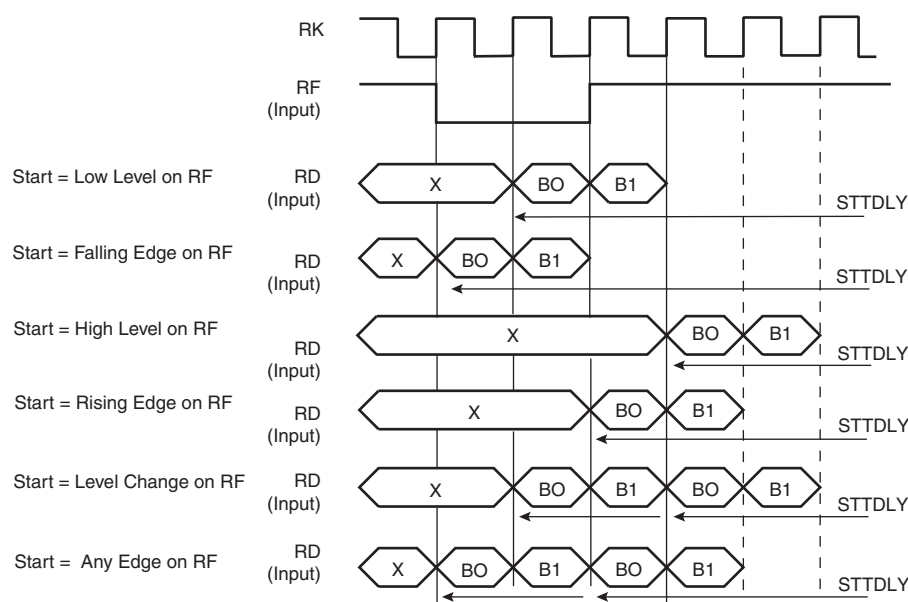

Figure 31-11. Receive Pulse/Edge Start Modes



31.6.5 Frame Sync

The Transmitter and Receiver Frame Sync pins, TF and RF, can be programmed to generate different kinds of frame synchronization signals. The Frame Sync Output Selection (FSOS) field in the Receive Frame Mode Register (SSC_RFMR) and in the Transmit Frame Mode Register (SSC_TFMR) are used to select the required waveform.

- Programmable low or high levels during data transfer are supported.
- Programmable high levels before the start of data transfers or toggling are also supported.

If a pulse waveform is selected, the Frame Sync Length (FSLEN) field in SSC_RFMR and SSC_TFMR programs the length of the pulse, from 1-bit time up to 16-bit time.

The periodicity of the Receive and Transmit Frame Sync pulse output can be programmed through the Period Divider Selection (PERIOD) field in SSC_RCMR and SSC_TCMR.

31.6.5.1 *Frame Sync Data*

Frame Sync Data transmits or receives a specific tag during the Frame Synchro signal.

During the Frame Sync signal, the Receiver can sample the RD line and store the data in the Receive Sync Holding Register and the transmitter can transfer Transmit Sync Holding Register in the Shifter Register. The data length to be sampled/shifted out during the Frame Sync signal is programmed by the FSLEN field in SSC_RFMR/SSC_TFMR.

Concerning the Receive Frame Sync Data operation, if the Frame Sync Length is equal to or lower than the delay between the start event and the actual data reception, the data sampling operation is performed in the Receive Sync Holding Register through the Receive Shift Register.

The Transmit Frame Sync Operation is performed by the transmitter only if the bit Frame Sync Data Enable (FSDEN) in SSC_TFMR is set. If the Frame Sync length is equal to or lower than the delay between the start event and the actual data transmission, the normal transmission has priority and the data contained in the Transmit Sync Holding Register is transferred in the Transmit Register then shifted out.

31.6.5.2 *Frame Sync Edge Detection*

The Frame Sync Edge detection is programmed by the FSEDGE field in SSC_RFMR/SSC_TFMR. This sets the corresponding flags RXSYN/TXSYN in the SSC Status Register (SSC_SR) on frame synchro edge detection (signals RF/TF).

31.6.6 **Data Format**

The data framing format of both the transmitter and the receiver are largely programmable through the Transmitter Frame Mode Register (SSC_TFMR) and the Receiver Frame Mode Register (SSC_RFMR). In either case, the user can independently select:

- The event that starts the data transfer (START).
- The delay in number of bit periods between the start event and the first data bit (STTDLY).
- The length of the data (DATLEN)
- The number of data to be transferred for each start event (DATNB).
- The length of Synchronization transferred for each start event (FSLEN).
- The bit sense: most or lowest significant bit first (MSBF).

Additionally, the transmitter can be used to transfer Synchronization and select the level driven on the TD pin while not in data transfer operation. This is done respectively by the Frame Sync Data Enable (FSDEN) and by the Data Default Value (DATDEF) bits in SSC_TFMR.

Table 31-3. Data Frame Registers

Transmitter	Receiver	Field	Length	Comment
SSC_TFMR	SSC_RFMR	DATLEN	Up to 32	Size of word
SSC_TFMR	SSC_RFMR	DATNB	Up to 16	Number Word transmitter in frame
SSC_TFMR	SSC_RFMR	MSBF		1 most significant bit in first
SSC_TFMR	SSC_RFMR	FSLEN	Up to 16	Size of Synchro data register
SSC_TFMR		DATDEF	0 or 1	Data default value ended
SSC_TFMR		FSDEN		Enable send SSC_TSHR
SSC_TCMR	SSC_RCMR	PERIOD	up to 512	Frame size
SSC_TCMR	SSC_RCMR	STTDLY	up to 255	Size of transmit start delay

Figure 31-12. Transmit and Receive Frame Format in Edge/Pulse Start Modes

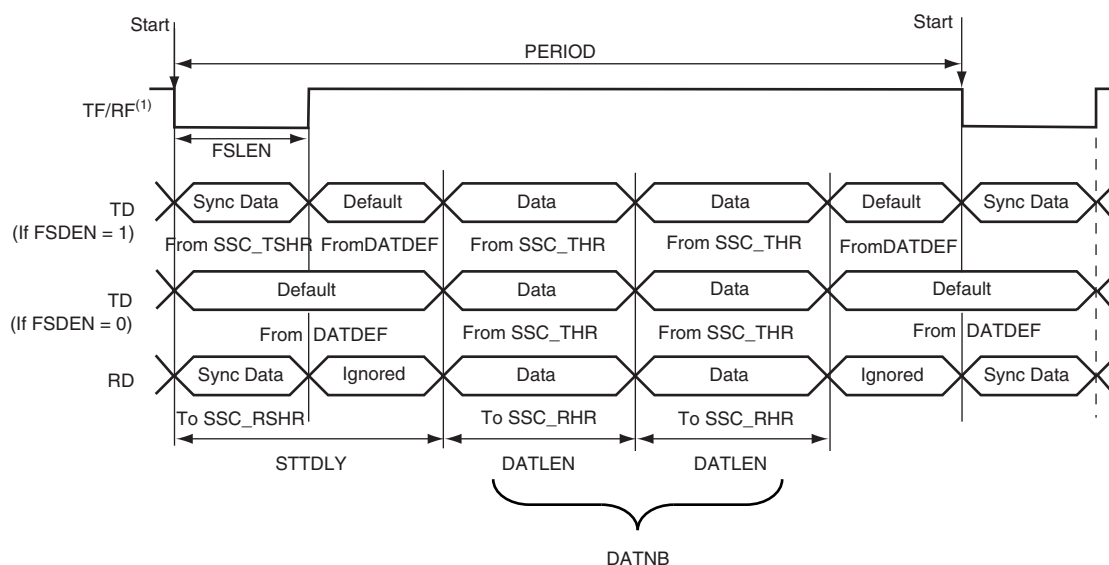

Note: 1. Input on falling edge on TF/RF example.

Figure 31-13. Transmit Frame Format in Continuous Mode

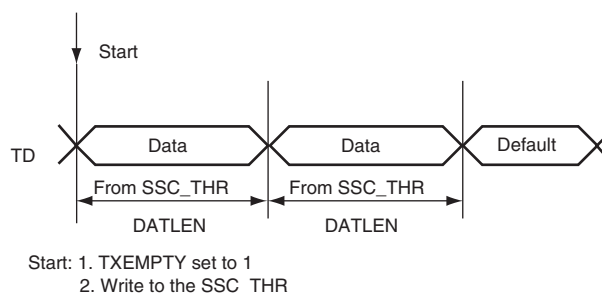

Note: 1. STTDLY is set to 0. In this example, SSC_THR is loaded twice. The value of FSDEN has no effect on transmission. SyncData cannot be output in continuous mode.

Figure 31-14. Receive Frame Format in Continuous Mode

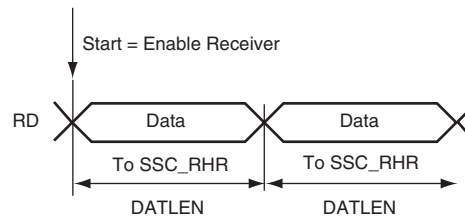

Note: 1. STTDLY is set to 0.

31.6.7 Loop Mode

The receiver can be programmed to receive transmissions from the transmitter. This is done by setting the Loop Mode (LOOP) bit in SSC_RFMR. In this case, RD is connected to TD, RF is connected to TF and RK is connected to TK.

31.6.8 Interrupt

Most bits in SSC_SR have a corresponding bit in interrupt management registers.

The SSC Controller can be programmed to generate an interrupt when it detects an event. The Interrupt is controlled by writing SSC_IER (Interrupt Enable Register) and SSC_IDR (Interrupt Disable Register), which respectively enable and disable the corresponding interrupt by setting and clearing the corresponding bit in SSC_IMR (Interrupt Mask Register), which controls the generation of interrupts by asserting the SSC interrupt line connected to the AIC.

Figure 31-15. Interrupt Block Diagram

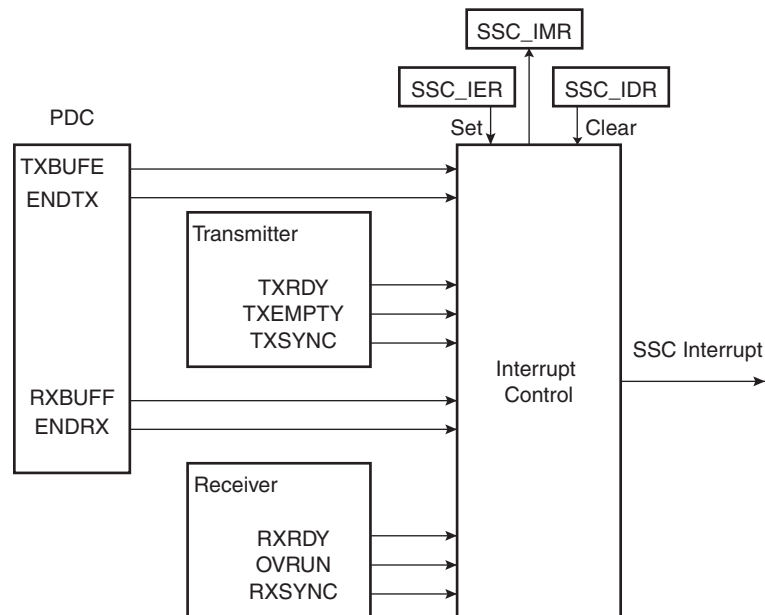

31.7 SSC Application Examples

The SSC can support several serial communication modes used in audio or high speed serial links. Some standard applications are shown in the following figures. All serial link applications supported by the SSC are not listed here.

Figure 31-16. Audio Application Block Diagram

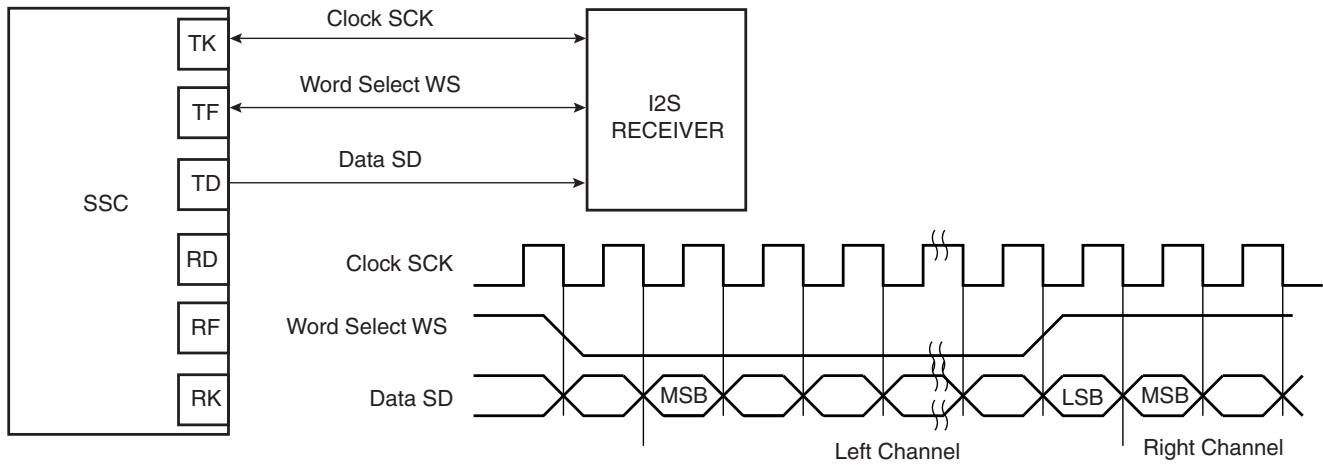

Figure 31-17. Codec Application Block Diagram

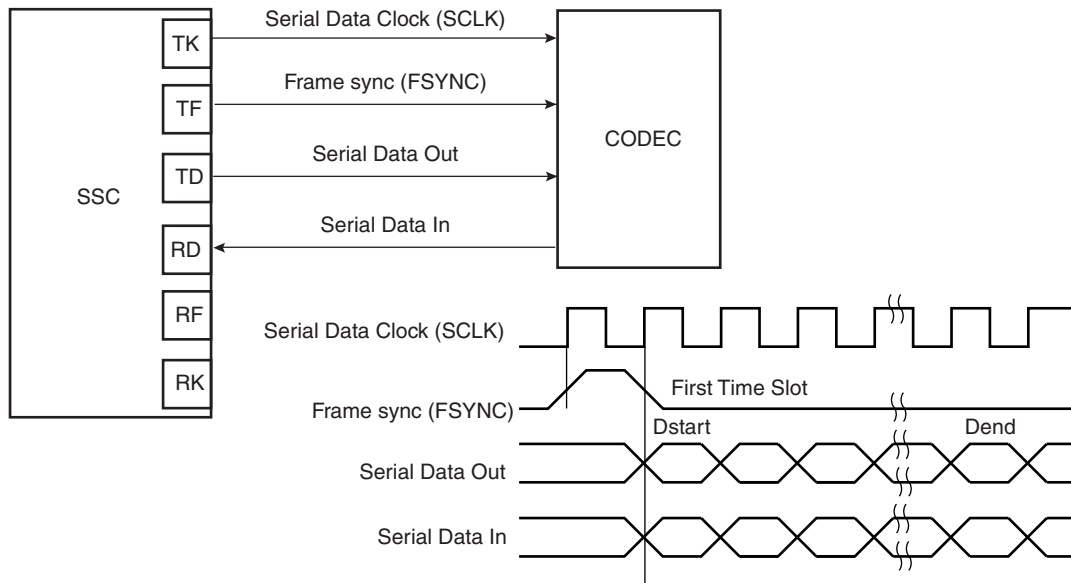
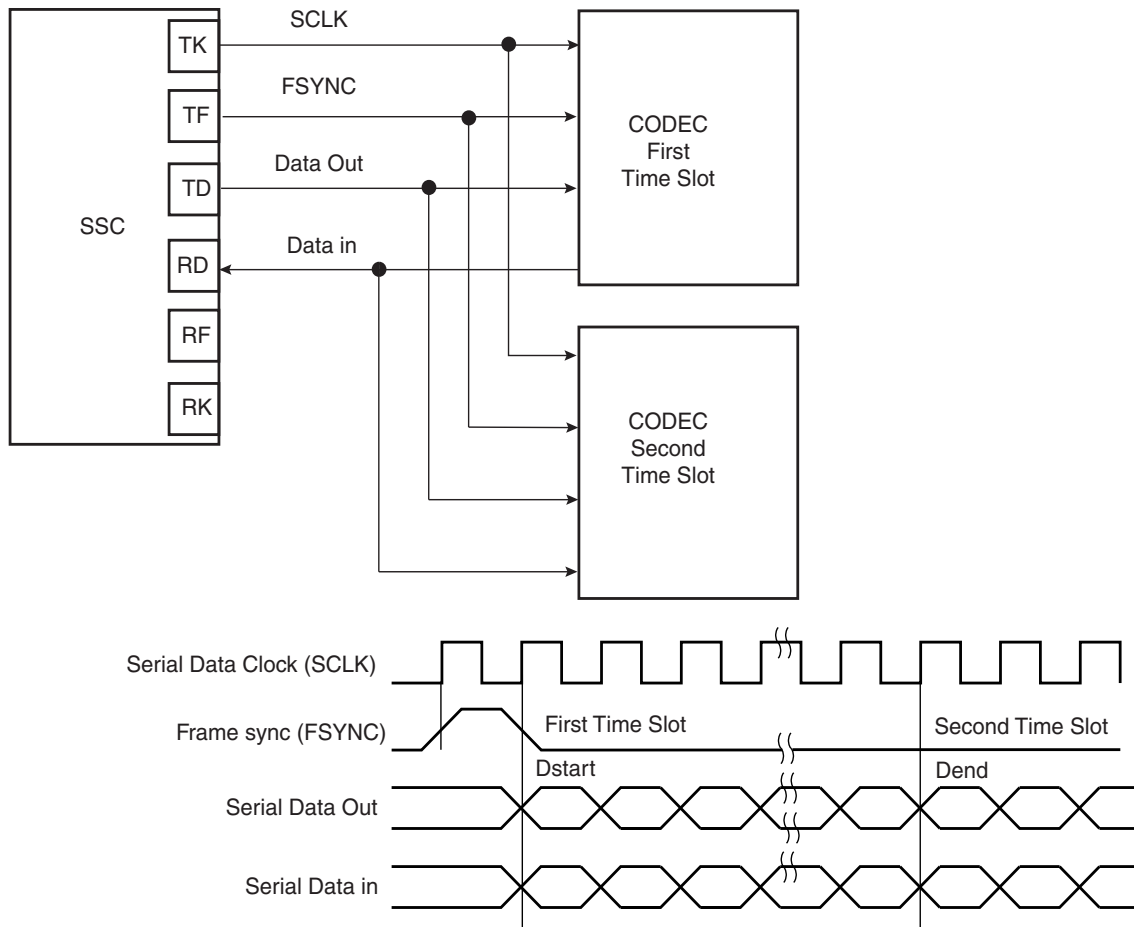

Figure 31-18. Time Slot Application Block Diagram



31.8 Serial Synchronous Controller (SSC) User Interface

Table 31-4. SSC Register Mapping

Offset	Register	Register Name	Access	Reset
0x0	Control Register	SSC_CR	Write	–
0x4	Clock Mode Register	SSC_CMR	Read/Write	0x0
0x8	Reserved	–	–	–
0xC	Reserved	–	–	–
0x10	Receive Clock Mode Register	SSC_RCMR	Read/Write	0x0
0x14	Receive Frame Mode Register	SSC_RFMR	Read/Write	0x0
0x18	Transmit Clock Mode Register	SSC_TCMR	Read/Write	0x0
0x1C	Transmit Frame Mode Register	SSC_TFMR	Read/Write	0x0
0x20	Receive Holding Register	SSC_RHR	Read	0x0
0x24	Transmit Holding Register	SSC_THR	Write	–
0x28	Reserved	–	–	–
0x2C	Reserved	–	–	–
0x30	Receive Sync. Holding Register	SSC_RSHR	Read	0x0
0x34	Transmit Sync. Holding Register	SSC_TSHR	Read/Write	0x0
0x38	Reserved	–	–	–
0x3C	Reserved	–	–	–
0x40	Status Register	SSC_SR	Read	0x000000CC
0x44	Interrupt Enable Register	SSC_IER	Write	–
0x48	Interrupt Disable Register	SSC_IDR	Write	–
0x4C	Interrupt Mask Register	SSC_IMR	Read	0x0
0x50-0xFF	Reserved	–	–	–
0x100- 0x124	Reserved for Peripheral DMA Controller (PDC)	–	–	–

31.8.1 SSC Control Register

Register Name: SSC_CR

Access Type: Write-only

31	30	29	28	27	26	25	24
–	–	–	–	–	–	–	–
23	22	21	20	19	18	17	16
–	–	–	–	–	–	–	–
15	14	13	12	11	10	9	8
SWRST	–	–	–	–	–	TXDIS	TXEN
7	6	5	4	3	2	1	0
–	–	–	–	–	–	RXDIS	RXEN

- **RXEN: Receive Enable**

0: No effect.

1: Enables Data Receive if RXDIS is not set⁽¹⁾.

- **RXDIS: Receive Disable**

0: No effect.

1: Disables Data Receive⁽¹⁾.

- **TXEN: Transmit Enable**

0: No effect.

1: Enables Data Transmit if TXDIS is not set⁽¹⁾.

- **TXDIS: Transmit Disable**

0: No effect.

1: Disables Data Transmit⁽¹⁾.

- **SWRST: Software Reset**

0: No effect.

1: Performs a software reset. Has priority on any other bit in SSC_CR.

Note: 1. Only the data management is affected

31.8.2 SSC Clock Mode Register

Register Name: SSC_CMCR

Access Type: Read/Write

31	30	29	28	27	26	25	24
–	–	–	–	–	–	–	–
23	22	21	20	19	18	17	16
–	–	–	–	–	–	–	–
15	14	13	12	11	10	9	8
–	–	–	–	DIV			
7	6	5	4	3	2	1	0
DIV							

- DIV: Clock Divider**

0: The Clock Divider is not active.

Any Other Value: The Divided Clock equals the Master Clock divided by 2 times DIV. The maximum bit rate is MCK/2. The minimum bit rate is $MCK/2 \times 4095 = MCK/8190$.

31.8.3 SSC Receive Clock Mode Register

Register Name: SSC_RCMR

Access Type: Read/Write

31	30	29	28	27	26	25	24
PERIOD							
23	22	21	20	19	18	17	16
STTDLY							
15	14	13	12	11	10	9	8
–	–	–	–	START			
7	6	5	4	3	2	1	0
–	–	CKI	CKO			CKS	

- CKS: Receive Clock Selection**

CKS	Selected Receive Clock
0x0	Divided Clock
0x1	TK Clock Signal
0x2	RK Pin
0x3	Reserved

- CKO: Receive Clock Output Mode Selection**

CKO	Receive Clock Output Mode	RK pin
0x0	None	Input-only
0x1	Continuous Receive Clock	Output
0x2-0x7	Reserved	

- **CKI: Receive Clock Inversion**

0: The data and the Frame Sync signal are sampled on Receive Clock falling edge.

1: The data and the Frame Sync signal are shifted out on Receive Clock rising edge.

CKI does not affect the RK output clock signal.

- **START: Receive Start Selection**

START	Receive Start
0x0	Continuous, as soon as the receiver is enabled, and immediately after the end of transfer of the previous data.
0x1	Transmit Start
0x2	Detection of a low level on RF input
0x3	Detection of a high level on RF input
0x4	Detection of a falling edge on RF input
0x5	Detection of a rising edge on RF input
0x6	Detection of any level change on RF input
0x7	Detection of any edge on RF input
0x8-0xF	Reserved

- **STTDLY: Receive Start Delay**

If STTDLY is not 0, a delay of STTDLY clock cycles is inserted between the start event and the actual start of reception. When the Receiver is programmed to start synchronously with the Transmitter, the delay is also applied.

Please Note: It is very important that STTDLY be set carefully. If STTDLY must be set, it should be done in relation to TAG (Receive Sync Data) reception.

- **PERIOD: Receive Period Divider Selection**

This field selects the divider to apply to the selected Receive Clock in order to generate a new Frame Sync Signal. If 0, no PERIOD signal is generated. If not 0, a PERIOD signal is generated each 2 x (PERIOD+1) Receive Clock.

31.8.4 SSC Receive Frame Mode Register

Register Name: SSC_RFMR

Access Type: Read/Write

31	30	29	28	27	26	25	24	
–	–	–	–	–	–	–	FSEDGE	
23	22	21	20	19	18	17	16	
–	FSOS				FSLEN			
15	14	13	12	11	10	9	8	
–	–	–	–	DATNB				
7	6	5	4	3	2	1	0	
MSBF	–	LOOP	DATLEN					

- **DATLEN: Data Length**

0x0 is not supported. The value of DATLEN can be set between 0x1 and 0x1F.

The bit stream contains DATLEN + 1 data bits. Moreover, it defines the transfer size performed by the PDC assigned to the Receiver.

If DATLEN is less than or equal to 7, data transfers are in bytes. If DATLEN is between 8 and 15 (included), half-words are transferred. For any other value, 32-bit words are transferred.

- **LOOP: Loop Mode**

0: Normal operating mode.

1: RD is driven by TD, RF is driven by TF and TK drives RK.

- **MSBF: Most Significant Bit First**

0: The lowest significant bit of the data register is sampled first in the bit stream.

1: The most significant bit of the data register is sampled first in the bit stream.

- **DATNB: Data Number per Frame**

This field defines the number of data words to be received after each transfer start. If 0, only 1 data word is transferred. Up to 16 data words can be transferred.

- **FSLEN: Receive Frame Sync Length**

This field defines the length of the Receive Frame Sync Signal and the number of bits sampled and stored in the Receive Sync Data Register. Only when FSOS is set on negative or positive pulse.

- **FSOS: Receive Frame Sync Output Selection**

FSOS	Selected Receive Frame Sync Signal	RF pin
0x0	None	Input-only
0x1	Negative Pulse	Output
0x2	Positive Pulse	Output
0x3	Driven Low during data transfer	Output
0x4	Driven High during data transfer	Output
0x5	Toggling at each start of data transfer	Output
0x6-0x7	Reserved	Undefined



- **FSEDGE: Frame Sync Edge Detection**

Determines which edge on Frame Sync sets RXSYN in the SSC Status Register.

FSEDGE	Frame Sync Edge Detection
0x0	Positive Edge Detection
0x1	Negative Edge Detection



31.8.5 SSC Transmit Clock Mode Register

Register Name: SSC_TCMR

Access Type: Read/Write

31	30	29	28	27	26	25	24
PERIOD							
23	22	21	20	19	18	17	16
STTDLY							
15	14	13	12	11	10	9	8
START							
7	6	5	4	3	2	1	0
-		CKI		CKO		CKS	

• CKS: Transmit Clock Selection

CKS	Selected Transmit Clock
0x0	Divided Clock
0x1	RK Clock signal
0x2	TK Pin
0x3	Reserved

• CKO: Transmit Clock Output Mode Selection

CKO	Transmit Clock Output Mode	TK pin
0x0	None	Input-only
0x1	Continuous Transmit Clock	Output
0x2-0x7	Reserved	

• CKI: Transmit Clock Inversion

0: The data and the Frame Sync signal are shifted out on Transmit Clock falling edge.

1: The data and the Frame Sync signal are shifted out on Transmit Clock rising edge.

CKI affects only the Transmit Clock and not the output clock signal.

• START: Transmit Start Selection

START	Transmit Start
0x0	Continuous, as soon as a word is written in the SSC_THR Register (if Transmit is enabled) and immediately after the end of transfer of the previous data.
0x1	Receive Start
0x2	Detection of a low level on TF signal
0x3	Detection of a high level on TF signal
0x4	Detection of a falling edge on TF signal
0x5	Detection of a rising edge on TF signal
0x6	Detection of any level change on TF signal
0x7	Detection of any edge on TF signal
0x8-0xF	Reserved

- **STTDLY: Transmit Start Delay**

If STTDLY is not 0, a delay of STTDLY clock cycles is inserted between the start event and the actual start of transmission of data. When the Transmitter is programmed to start synchronously with the Receiver, the delay is also applied.

Please Note: STTDLY must be set carefully. If STTDLY is too short in respect to TAG (Transmit Sync Data) emission, data is emitted instead of the end of TAG.

- **PERIOD: Transmit Period Divider Selection**

This field selects the divider to apply to the selected Transmit Clock to generate a new Frame Sync Signal. If 0, no period signal is generated. If not 0, a period signal is generated at each $2 \times (\text{PERIOD} + 1)$ Transmit Clock.

31.8.6 SSC Transmit Frame Mode Register

Register Name: SSC_TFMR

Access Type: Read/Write

31	30	29	28	27	26	25	24	
–	–	–	–	–	–	–	FSEDGE	
23	22	21	20	19	18	17	16	
FSDEN	FSOS			FSLEN				
15	14	13	12	11	10	9	8	
–	–	–	–	DATNB				
7	6	5	4	3	2	1	0	
MSBF	–	DATDEF	DATLEN					

- **DATLEN: Data Length**

0x0 is not supported. The value of DATLEN can be set between 0x1 and 0x1F.

The bit stream contains DATLEN + 1 data bits. Moreover, it defines the transfer size performed by the PDC assigned to the Receiver.

If DATLEN is less than or equal to 7, data transfers are in bytes. If DATLEN is between 8 and 15 (included), half-words are transferred. For any other value, 32-bit words are transferred.

- **DATDEF: Data Default Value**

This bit defines the level driven on the TD pin while out of transmission. Note that if the pin is defined as multi-drive by the PIO Controller, the pin is enabled only if the SCC TD output is 1.

- **MSBF: Most Significant Bit First**

0: The lowest significant bit of the data register is shifted out first in the bit stream.

1: The most significant bit of the data register is shifted out first in the bit stream.

- **DATNB: Data Number per frame**

This field defines the number of data words to be transferred after each transfer start. If 0, only 1 data word is transferred and up to 16 data words can be transferred.

- **FSLEN: Transmit Frame Sync Length**

This field defines the length of the Transmit Frame Sync signal and the number of bits shifted out from the Transmit Sync Data Register if FSDEN is 1. If 0, the Transmit Frame Sync signal is generated during one Transmit Clock period and up to 16 clock period pulse length is possible.

- **FSOS: Transmit Frame Sync Output Selection**

FSOS	Selected Transmit Frame Sync Signal	TF pin
0x0	None	Input-only
0x1	Negative Pulse	Output
0x2	Positive Pulse	Output
0x3	Driven Low during data transfer	Output
0x4	Driven High during data transfer	Output
0x5	Toggling at each start of data transfer	Output
0x6-0x7	Reserved	Undefined

- **FSDEN: Frame Sync Data Enable**

0: The TD line is driven with the default value during the Transmit Frame Sync signal.

1: SSC_TSHR value is shifted out during the transmission of the Transmit Frame Sync signal.

- **FSEDGE: Frame Sync Edge Detection**

Determines which edge on frame sync sets TXSYN (Status Register).

FSEDGE	Frame Sync Edge Detection
0x0	Positive Edge Detection
0x1	Negative Edge Detection

31.8.7 SSC Receive Holding Register

Register Name: SSC_RHR

Access Type: Read-only

31	30	29	28	27	26	25	24
RDAT							
23	22	21	20	19	18	17	16
RDAT							
15	14	13	12	11	10	9	8
RDAT							
7	6	5	4	3	2	1	0
RDAT							

- **RDAT: Receive Data**

Right aligned regardless of the number of data bits defined by DATLEN in SSC_RFMR.

31.8.8 SSC Transmit Holding Register

Register Name: SSC_THR

Access Type: Write only

31	30	29	28	27	26	25	24
TDAT							
23	22	21	20	19	18	17	16
TDAT							
15	14	13	12	11	10	9	8
TDAT							
7	6	5	4	3	2	1	0
TDAT							

TDAT: Transmit Data

Right aligned regardless of the number of data bits defined by DATLEN in SSC_TFMR.

31.8.9 SSC Receive Synchronization Holding Register

Register Name: SSC_RSHR

Access Type: Read/Write

31	30	29	28	27	26	25	24
–	–	–	–	–	–	–	–
23	22	21	20	19	18	17	16
–	–	–	–	–	–	–	–
15	14	13	12	11	10	9	8
RSDAT							
7	6	5	4	3	2	1	0
RSDAT							

- **RSDAT: Receive Synchronization Data**

Right aligned regardless of the number of data bits defined by FSLEN in SSC_RFMR.

31.8.10 SSC Transmit Synchronization Holding Register

Name: SSC_TSHR

Access Type: Read/Write

31	30	29	28	27	26	25	24
–	–	–	–	–	–	–	–
23	22	21	20	19	18	17	16
–	–	–	–	–	–	–	–
15	14	13	12	11	10	9	8
TSDAT							
7	6	5	4	3	2	1	0
TSDAT							

- **TSDAT: Transmit Synchronization Data**

Right aligned regardless of the number of data bits defined by FSLEN in SSC_TFMR.

31.8.11 SSC Status Register

Register Name: SSC_SR

Access Type: Read-only

31	30	29	28	27	26	25	24
–	–	–	–	–	–	–	–
23	22	21	20	19	18	17	16
–	–	–	–	–	–	RXEN	TXEN
15	14	13	12	11	10	9	8
–	–	–	–	RXSYN	TXSYN	–	–
7	6	5	4	3	2	1	0
RXBUFF	ENDRX	OVRUN	RXRDY	TXBUFE	ENDTX	TXEMPTY	TXRDY

- **TXRDY: Transmit Ready**

0: Data has been loaded in SSC_THR and is waiting to be loaded in the Transmit Shift Register.

1: SSC_THR is empty.

- **TXEMPTY: Transmit Empty**

0: Data remains in SSC_THR or is currently transmitted from Transmit Shift Register.

1: Last data written in SSC_THR has been loaded in Transmit Shift Register and transmitted by it.

- **ENDTX: End of Transmission**

0: The register SSC_TCR has not reached 0 since the last write in SSC_TCR or SSC_TNCR.

1: The register SSC_TCR has reached 0 since the last write in SSC_TCR or SSC_TNCR.

- **TXBUFE: Transmit Buffer Empty**

0: SSC_TCR or SSC_TNCR have a value other than 0.

1: Both SSC_TCR and SSC_TNCR have a value of 0.

- **RXRDY: Receive Ready**

0: SSC_RHR is empty.

1: Data has been received and loaded in SSC_RHR.

- **OVRUN: Receive Overrun**

0: No data has been loaded in SSC_RHR while previous data has not been read since the last read of the Status Register.

1: Data has been loaded in SSC_RHR while previous data has not yet been read since the last read of the Status Register.

- **ENDRX: End of Reception**

0: Data is written on the Receive Counter Register or Receive Next Counter Register.

1: End of PDC transfer when Receive Counter Register has arrived at zero.

- **RXBUFF: Receive Buffer Full**

0: SSC_RCR or SSC_RNCR have a value other than 0.

1: Both SSC_RCR and SSC_RNCR have a value of 0.

- **TXSYN: Transmit Sync**

0: A Tx Sync has not occurred since the last read of the Status Register.

1: A Tx Sync has occurred since the last read of the Status Register.

- **RXSYN: Receive Sync**

0: A Rx Sync has not occurred since the last read of the Status Register.

1: A Rx Sync has occurred since the last read of the Status Register.

- **TXEN: Transmit Enable**

0: Transmit data is disabled.

1: Transmit data is enabled.

- **RXEN: Receive Enable**

0: Receive data is disabled.

1: Receive data is enabled.

31.8.12 SSC Interrupt Enable Register

Register Name: SSC_IER

Access Type: Write-only

31	30	29	28	27	26	25	24
–	–	–	–	–	–	–	–
23	22	21	20	19	18	17	16
–	–	–	–	–	–	–	–
15	14	13	12	11	10	9	8
–	–	–	–	RXSYN	TXSYN	–	–
7	6	5	4	3	2	1	0
RXBUFF	ENDRX	OVRUN	RXRDY	TXBUFE	ENDTX	TXEMPTY	TXRDY

- **TXRDY: Transmit Ready**
- **TXEMPTY: Transmit Empty**
- **ENDTX: End of Transmission**
- **TXBUFE: Transmit Buffer Empty**
- **RXRDY: Receive Ready**
- **OVRUN: Receive Overrun**
- **ENDRX: End of Reception**
- **RXBUFF: Receive Buffer Full**
- **TXSYN: Tx Sync**
- **RXSYN: Rx Sync**

0: No effect.

1: Enables the corresponding interrupt.

31.8.13 SSC Interrupt Disable Register

Register Name: SSC_IDR

Access Type: Write-only

31	30	29	28	27	26	25	24
–	–	–	–	–	–	–	–
23	22	21	20	19	18	17	16
–	–	–	–	–	–	–	–
15	14	13	12	11	10	9	8
–	–	–	–	RXSYN	TXSYN	–	–
7	6	5	4	3	2	1	0
RXBUFF	ENDRX	OVRUN	RXRDY	TXBUFE	ENDTX	TXEMPTY	TXRDY

- **TXRDY: Transmit Ready**
- **TXEMPTY: Transmit Empty**
- **ENDTX: End of Transmission**
- **TXBUFE: Transmit Buffer Empty**
- **RXRDY: Receive Ready**
- **OVRUN: Receive Overrun**
- **ENDRX: End of Reception**
- **RXBUFF: Receive Buffer Full**
- **TXSYN: Tx Sync**
- **RXSYN: Rx Sync**

0: No effect.

1: Disables the corresponding interrupt.

31.8.14 SSC Interrupt Mask Register

Register Name: SSC_IMR

Access Type: Read-only

31	30	29	28	27	26	25	24
–	–	–	–	–	–	–	–
23	22	21	20	19	18	17	16
–	–	–	–	–	–	–	–
15	14	13	12	11	10	9	8
–	–	–	–	RXSYN	TXSYN	–	–
7	6	5	4	3	2	1	0
RXBUFF	ENDRX	OVRUN	RXRDY	TXBUFE	ENDTX	TXEMPTY	TXRDY

- **TXRDY: Transmit Ready**
- **TXEMPTY: Transmit Empty**
- **ENDTX: End of Transmission**
- **TXBUFE: Transmit Buffer Empty**
- **RXRDY: Receive Ready**
- **OVRUN: Receive Overrun**
- **ENDRX: End of Reception**
- **RXBUFF: Receive Buffer Full**
- **TXSYN: Tx Sync**
- **RXSYN: Rx Sync**

0: The corresponding interrupt is disabled.

1: The corresponding interrupt is enabled.

32. Timer Counter (TC)

32.1 Overview

The Timer Counter (TC) includes three identical 16-bit Timer Counter channels.

Each channel can be independently programmed to perform a wide range of functions including frequency measurement, event counting, interval measurement, pulse generation, delay timing and pulse width modulation.

Each channel has three external clock inputs, five internal clock inputs and two multi-purpose input/output signals which can be configured by the user. Each channel drives an internal interrupt signal which can be programmed to generate processor interrupts.

The Timer Counter block has two global registers which act upon all three TC channels.

The Block Control Register allows the three channels to be started simultaneously with the same instruction.

The Block Mode Register defines the external clock inputs for each channel, allowing them to be chained.

Key Features of the Timer Counter are:

- Three 16-bit Timer Counter Channels
- A Wide Range of Functions Including:
 - Frequency Measurement
 - Event Counting
 - Interval Measurement
 - Pulse Generation
 - Delay Timing
 - Pulse Width Modulation
 - Up/down Capabilities
- Each Channel is User-configurable and Contains:
 - Three External Clock Inputs
 - Five Internal Clock Inputs
 - Two Multi-purpose Input/Output Signals
- Internal Interrupt Signal

Two Global Registers that Act on All Three TC Channels

32.2 Block Diagram

Figure 32-1. Timer Counter Block Diagram

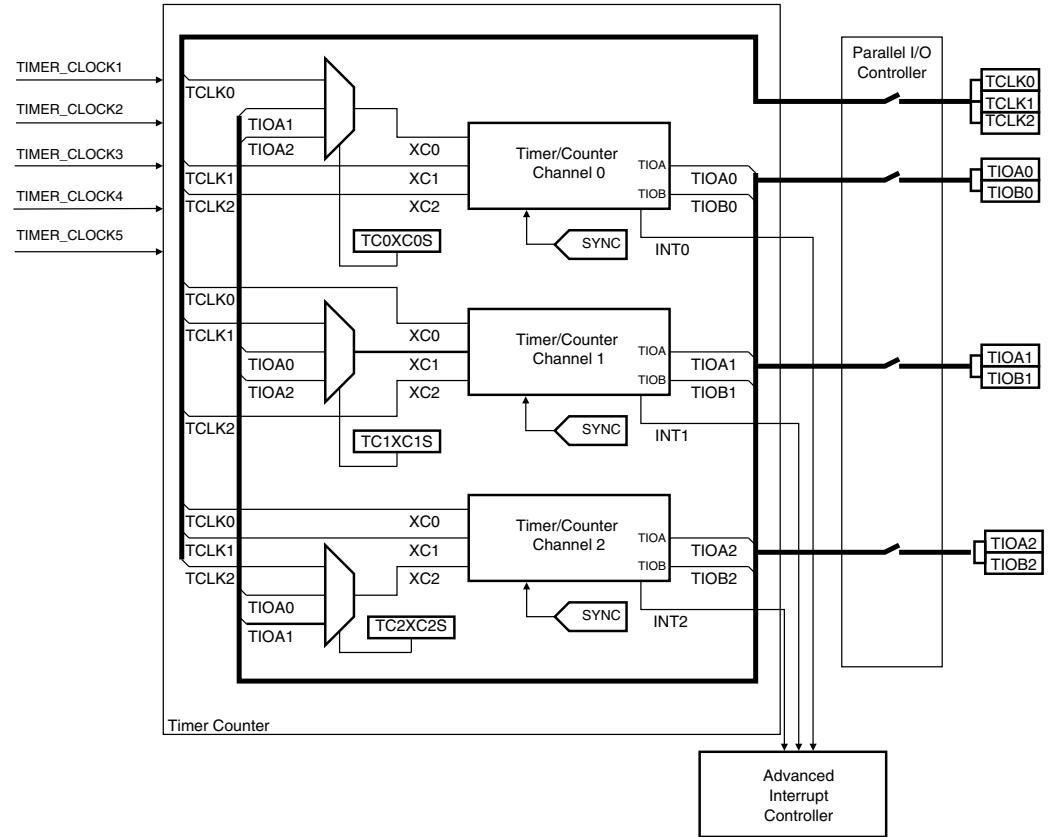

Table 32-1. Signal Name Description

Block/Channel	Signal Name	Description
Channel Signal	XC0, XC1, XC2	External Clock Inputs
	TIOA	Capture Mode: General-purpose Input Waveform Mode: General-purpose Output
	TIOB	Capture Mode: General-purpose Input Waveform Mode: General-purpose Input/output
	INT	Interrupt Signal Output
	SYNC	Synchronization Input Signal
Block Signal	TCLK0, TCLK1, TCLK2	External Clock Inputs
	TIOA0	TIOA Signal for Channel 0
	TIOB0	TIOB Signal for Channel 0
	TIOA1	TIOA Signal for Channel 1
	TIOB1	TIOB Signal for Channel 1
	TIOA2	TIOA Signal for Channel 2
	TIOB2	TIOB Signal for Channel 2

32.3 Pin Name List

Table 32-2. Timer Counter pin list

Pin Name	Description	Type
TCLK0-TCLK2	External Clock Input	Input
TIOA0-TIOA2	I/O Line A	I/O
TIOB0-TIOB2	I/O Line B	I/O

32.4 Product Dependencies

For further details on the Timer Counter hardware implementation, see the specific Product Properties document.

32.4.1 I/O Lines

The pins used for interfacing the compliant external devices may be multiplexed with PIO lines. The programmer must first program the PIO controllers to assign the TC pins to their peripheral functions.

32.4.2 Power Management

The TC must be clocked through the Power Management Controller (PMC), thus the programmer must first configure the PMC to enable the Timer Counter.

32.4.3 Interrupt

The TC interface has an interrupt line connected to the Advanced Interrupt Controller (AIC). Handling the TC interrupt requires programming the AIC before configuring the TC.

32.5 Functional Description

32.5.1 TC Description

The three channels of the Timer Counter are independent and identical in operation. The registers for channel programming are listed in [Table 32-2 on page 487](#).

32.5.1.1 16-bit Counter

Each channel is organized around a 16-bit counter. The value of the counter is incremented at each positive edge of the selected clock. When the counter has reached the value 0xFFFF and passes to 0x0000, an overflow occurs and the COVFS bit in TC_SR (Status Register) is set.

The current value of the counter is accessible in real time by reading the Counter Value Register, TC_CV. The counter can be reset by a trigger. In this case, the counter value passes to 0x0000 on the next valid edge of the selected clock.

32.5.1.2 Clock Selection

At block level, input clock signals of each channel can either be connected to the external inputs TCLK0, TCLK1 or TCLK2, or be connected to the configurable I/O signals TIOA0, TIOA1 or TIOA2 for chaining by programming the TC_BMR (Block Mode). See [Figure 32-2](#).

Each channel can independently select an internal or external clock source for its counter:

- Internal clock signals: TIMER_CLOCK1, TIMER_CLOCK2, TIMER_CLOCK3, TIMER_CLOCK4, TIMER_CLOCK5

- External clock signals: XC0, XC1 or XC2

This selection is made by the TCCLKS bits in the TC Channel Mode Register (Capture Mode).

The selected clock can be inverted with the CLKI bit in TC_CMR (Capture Mode). This allows counting on the opposite edges of the clock.

The burst function allows the clock to be validated when an external signal is high. The BURST parameter in the Mode Register defines this signal (none, XC0, XC1, XC2).

Note: In all cases, if an external clock is used, the duration of each of its levels must be longer than the master clock period. The external clock frequency must be at least 2.5 times lower than the master clock

Figure 32-2. Clock Selection

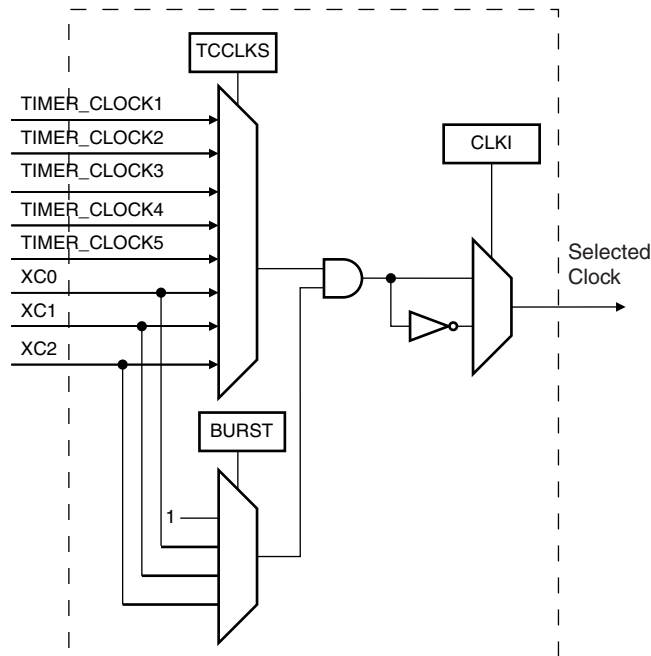

32.5.1.3 Clock Control

The clock of each counter can be controlled in two different ways: it can be enabled/disabled and started/stopped. See [Figure 32-3](#).

- The clock can be enabled or disabled by the user with the CLKEN and the CLKDIS commands in the Control Register. In Capture Mode it can be disabled by an RB load event if LDBDIS is set to 1 in TC_CMR. In Waveform Mode, it can be disabled by an RC Compare event if CPCDIS is set to 1 in TC_CMR. When disabled, the start or the stop actions have no effect: only a CLKEN command in the Control Register can re-enable the clock. When the clock is enabled, the CLKSTA bit is set in the Status Register.
- The clock can also be started or stopped: a trigger (software, synchro, external or compare) always starts the clock. The clock can be stopped by an RB load event in Capture Mode (LDBSTOP = 1 in TC_CMR) or a RC compare event in Waveform Mode (CPCSTOP = 1 in TC_CMR). The start and the stop commands have effect only if the clock is enabled.

Figure 32-3. Clock Control

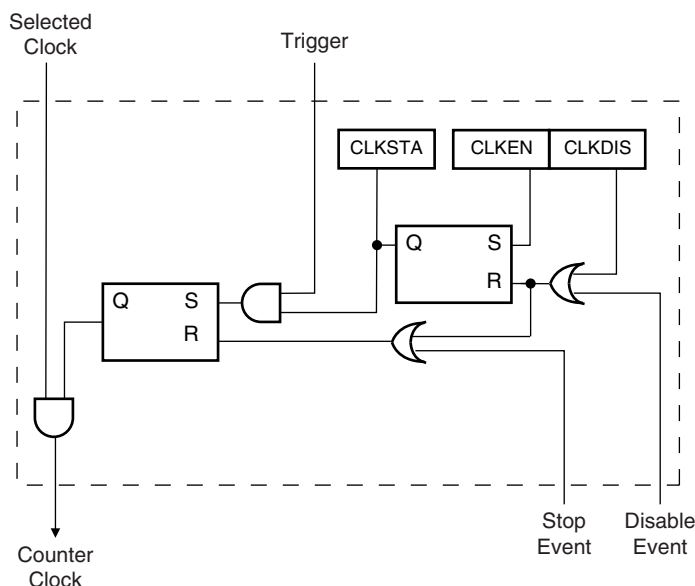

32.5.1.4 TC Operating Modes

Each channel can independently operate in two different modes:

- Capture Mode provides measurement on signals.
- Waveform Mode provides wave generation.

The TC Operating Mode is programmed with the WAVE bit in the TC Channel Mode Register.

In Capture Mode, TIOA and TIOB are configured as inputs.

In Waveform Mode, TIOA is always configured to be an output and TIOB is an output if it is not selected to be the external trigger.

32.5.1.5 Trigger

A trigger resets the counter and starts the counter clock. Three types of triggers are common to both modes, and a fourth external trigger is available to each mode.

The following triggers are common to both modes:

- Software Trigger: Each channel has a software trigger, available by setting SWTRG in TC_CCR.
- SYNC: Each channel has a synchronization signal SYNC. When asserted, this signal has the same effect as a software trigger. The SYNC signals of all channels are asserted simultaneously by writing TC_BCR (Block Control) with SYNC set.
- Compare RC Trigger: RC is implemented in each channel and can provide a trigger when the counter value matches the RC value if CPCTRG is set in TC_CMR.

The channel can also be configured to have an external trigger. In Capture Mode, the external trigger signal can be selected between TIOA and TIOB. In Waveform Mode, an external event can be programmed on one of the following signals: TIOB, XC0, XC1 or XC2. This external event can then be programmed to perform a trigger by setting ENETRIG in TC_CMR.

If an external trigger is used, the duration of the pulses must be longer than the master clock period in order to be detected.

Regardless of the trigger used, it will be taken into account at the following active edge of the selected clock. This means that the counter value can be read differently from zero just after a trigger, especially when a low frequency signal is selected as the clock.

32.5.2 Capture Operating Mode

This mode is entered by clearing the WAVE parameter in TC_CMR (Channel Mode Register).

Capture Mode allows the TC channel to perform measurements such as pulse timing, frequency, period, duty cycle and phase on TIOA and TIOB signals which are considered as inputs.

Figure 32-4 shows the configuration of the TC channel when programmed in Capture Mode.

32.5.2.1 Capture Registers A and B

Registers A and B (RA and RB) are used as capture registers. This means that they can be loaded with the counter value when a programmable event occurs on the signal TIOA.

The LDRA parameter in TC_CMR defines the TIOA edge for the loading of register A, and the LDRB parameter defines the TIOA edge for the loading of Register B.

RA is loaded only if it has not been loaded since the last trigger or if RB has been loaded since the last loading of RA.

RB is loaded only if RA has been loaded since the last trigger or the last loading of RB.

Loading RA or RB before the read of the last value loaded sets the Overrun Error Flag (LOVRS) in TC_SR (Status Register). In this case, the old value is overwritten.

32.5.2.2 Trigger Conditions

In addition to the SYNC signal, the software trigger and the RC compare trigger, an external trigger can be defined.

The ABETRG bit in TC_CMR selects TIOA or TIOB input signal as an external trigger. The ETRGEDG parameter defines the edge (rising, falling or both) detected to generate an external trigger. If ETRGEDG = 0 (none), the external trigger is disabled.

Figure 32-4. Capture Mode

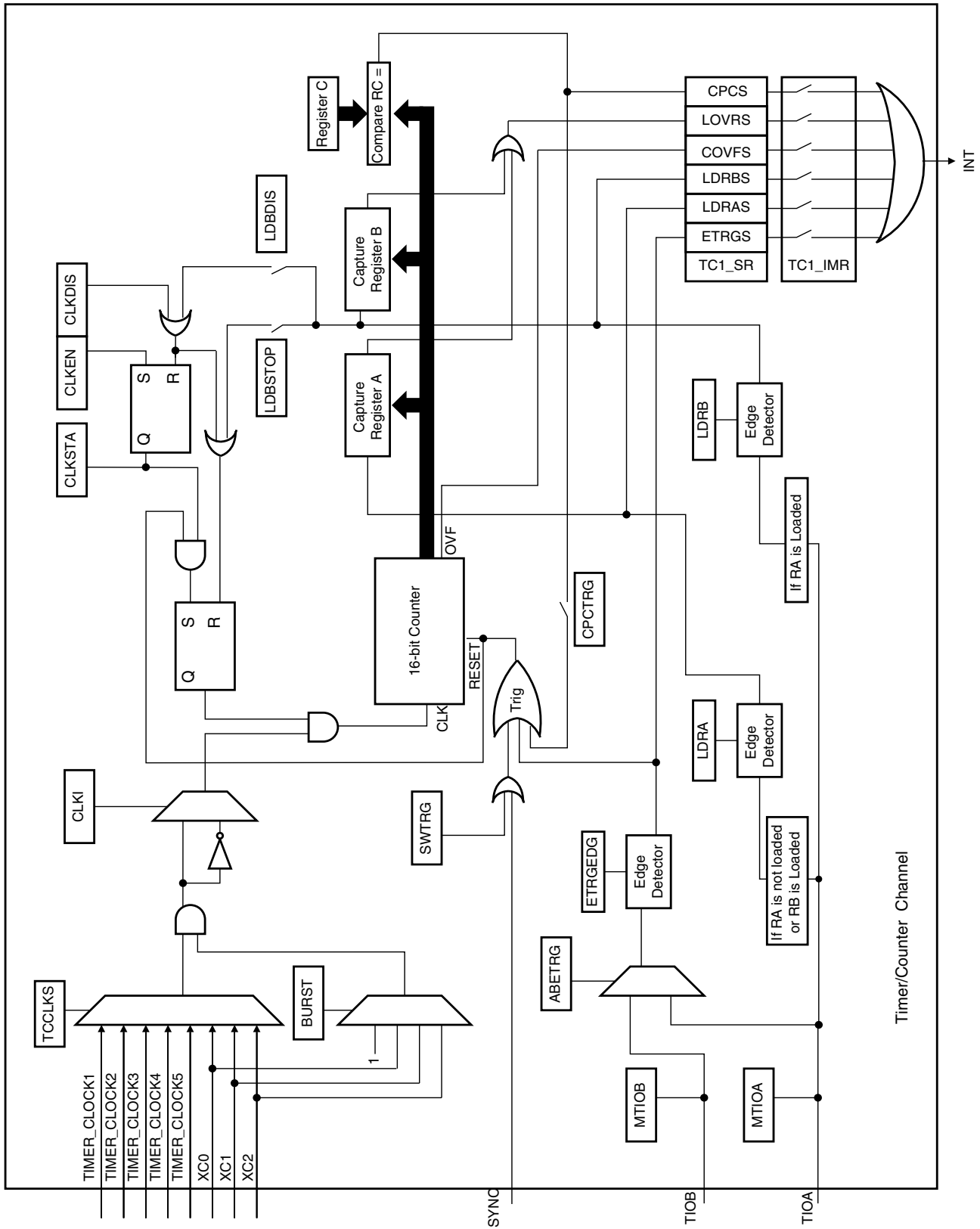

32.6 Waveform Operating Mode

Waveform operating mode is entered by setting the WAVE parameter in TC_CMR (Channel Mode Register).

In Waveform Operating Mode the TC channel generates 1 or 2 PWM signals with the same frequency and independently programmable duty cycles, or generates different types of one-shot or repetitive pulses.

In this mode, TIOA is configured as an output and TIOB is defined as an output if it is not used as an external event (EEVT parameter in TC_CMR).

Figure 32-5 shows the configuration of the TC channel when programmed in Waveform Operating Mode.

32.6.0.3 Waveform Selection

Depending on the WAVSEL parameter in TC_CMR (Channel Mode Register), the behavior of TC_CV varies.

With any selection, RA, RB and RC can all be used as compare registers.

RA Compare is used to control the TIOA output, RB Compare is used to control the TIOB output (if correctly configured) and RC Compare is used to control TIOA and/or TIOB outputs.

Figure 32-5. Waveform Mode

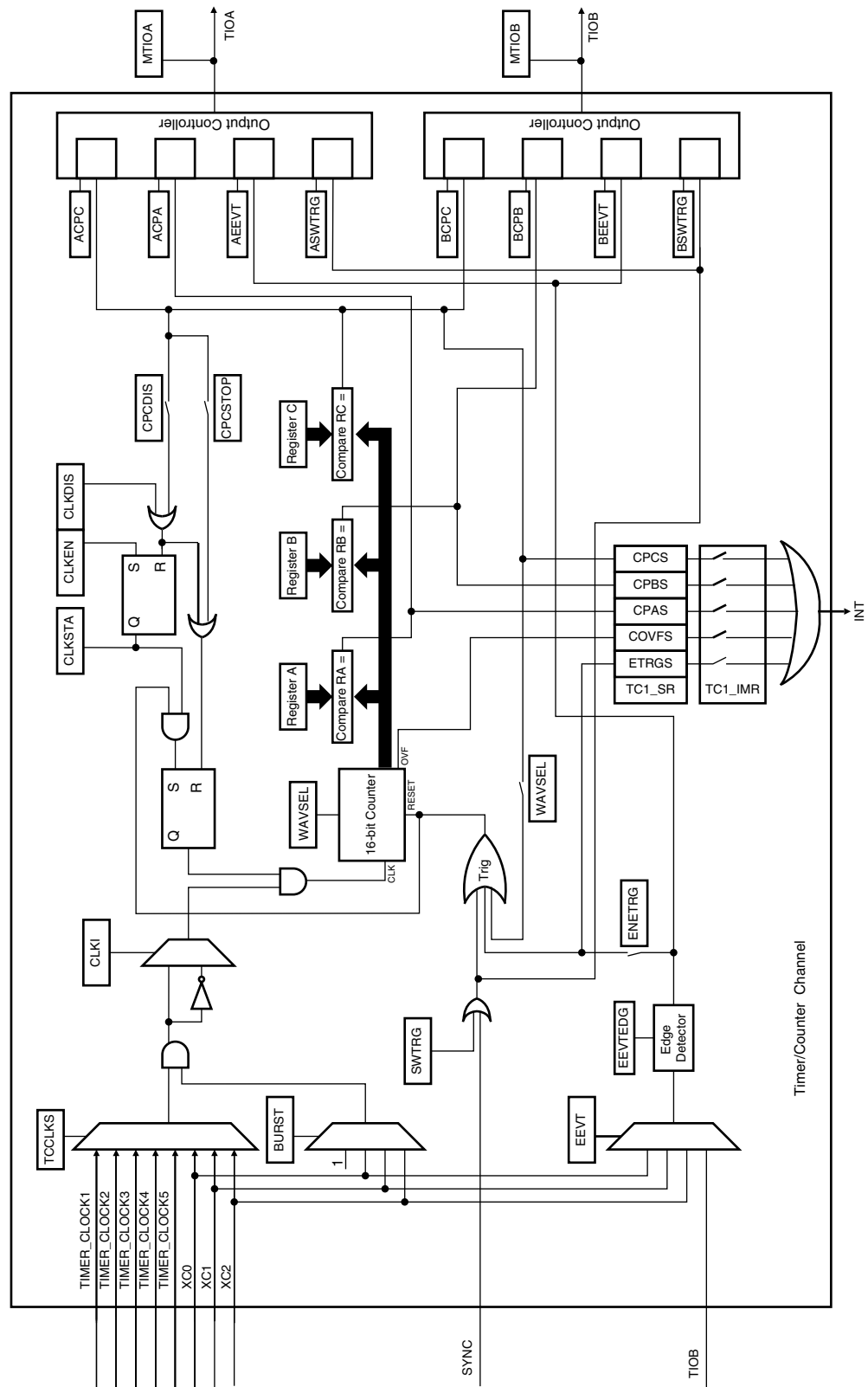

WAVSEL = 00

When WAVSEL = 00, the value of TC_CV is incremented from 0 to 0xFFFF. Once 0xFFFF has been reached, the value of TC_CV is reset. Incrementation of TC_CV starts again and the cycle continues. See [Figure 32-6](#).

An external event trigger or a software trigger can reset the value of TC_CV. It is important to note that the trigger may occur at any time. See [Figure 32-7](#).

RC Compare cannot be programmed to generate a trigger in this configuration. At the same time, RC Compare can stop the counter clock (CPCSTOP = 1 in TC_CMR) and/or disable the counter clock (CPCDIS = 1 in TC_CMR).

Figure 32-6. WAVSEL= 00 without trigger

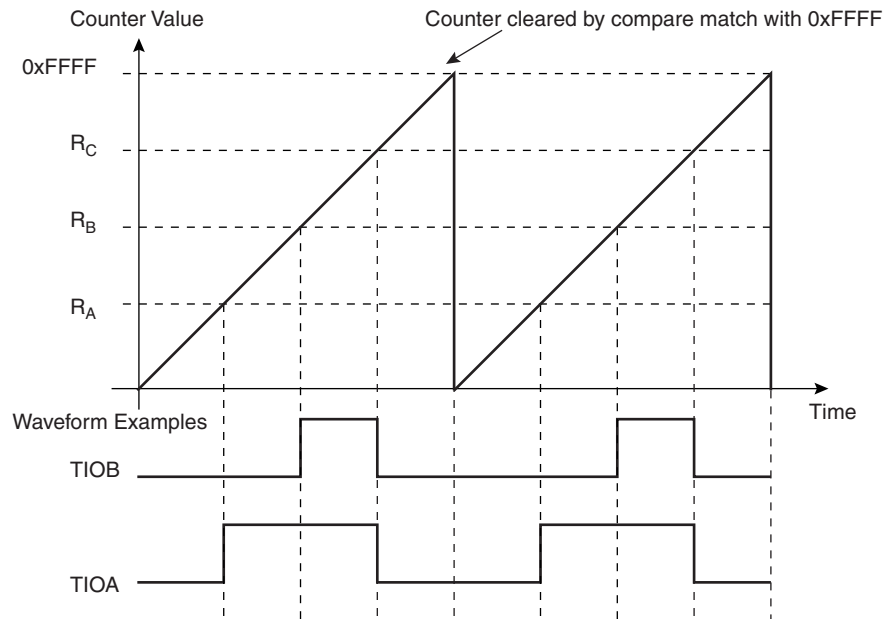
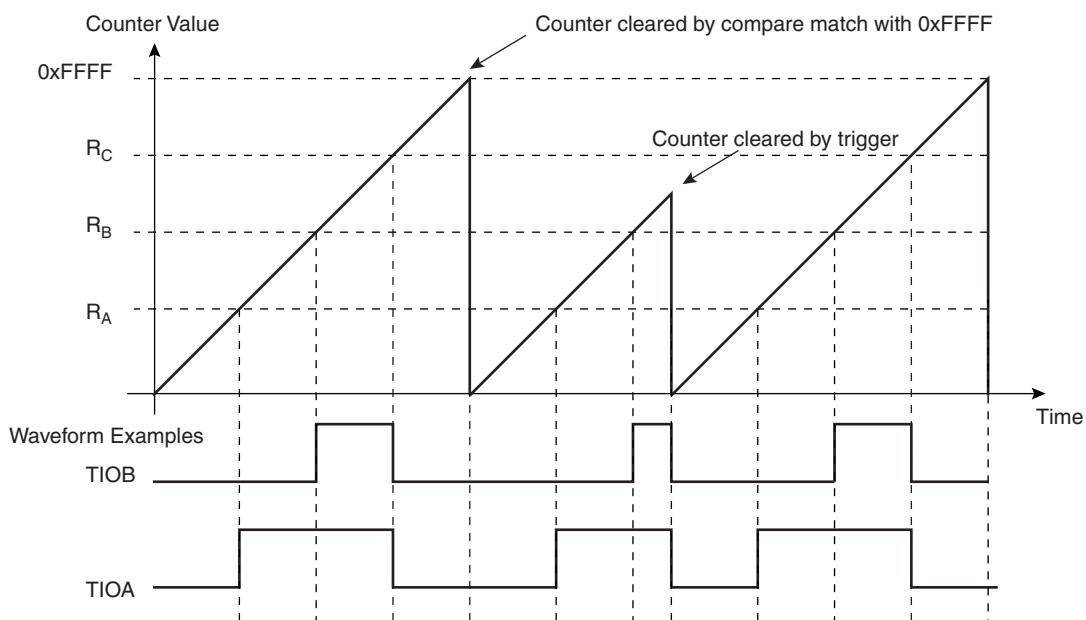

Figure 32-7. WAVSEL= 00 with trigger



WAVSEL = 10

When WAVSEL = 10, the value of TC_CV is incremented from 0 to the value of RC, then automatically reset on a RC Compare. Once the value of TC_CV has been reset, it is then incremented and so on. See [Figure 32-8](#).

It is important to note that TC_CV can be reset at any time by an external event or a software trigger if both are programmed correctly. See [Figure 32-9](#).

In addition, RC Compare can stop the counter clock (CPCSTOP = 1 in TC_CMR) and/or disable the counter clock (CPCDIS = 1 in TC_CMR).

Figure 32-8. WAVSEL = 10 Without Trigger

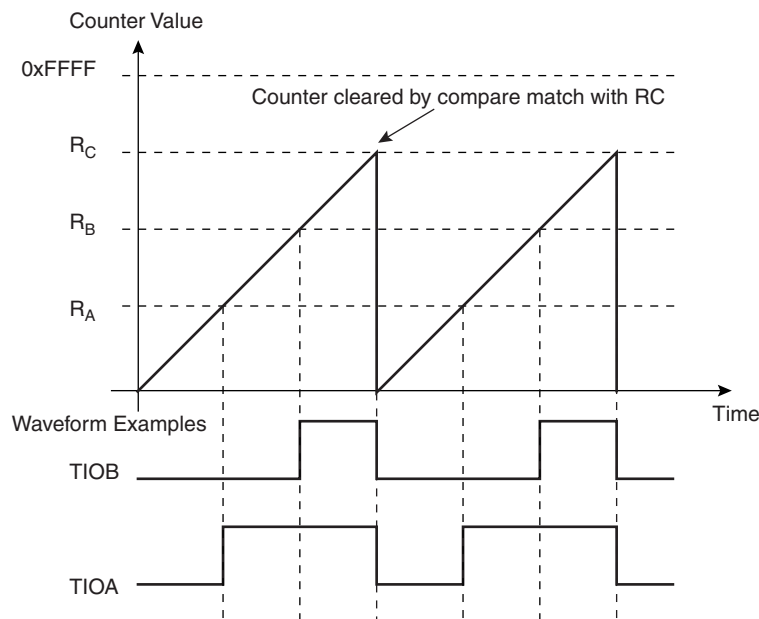
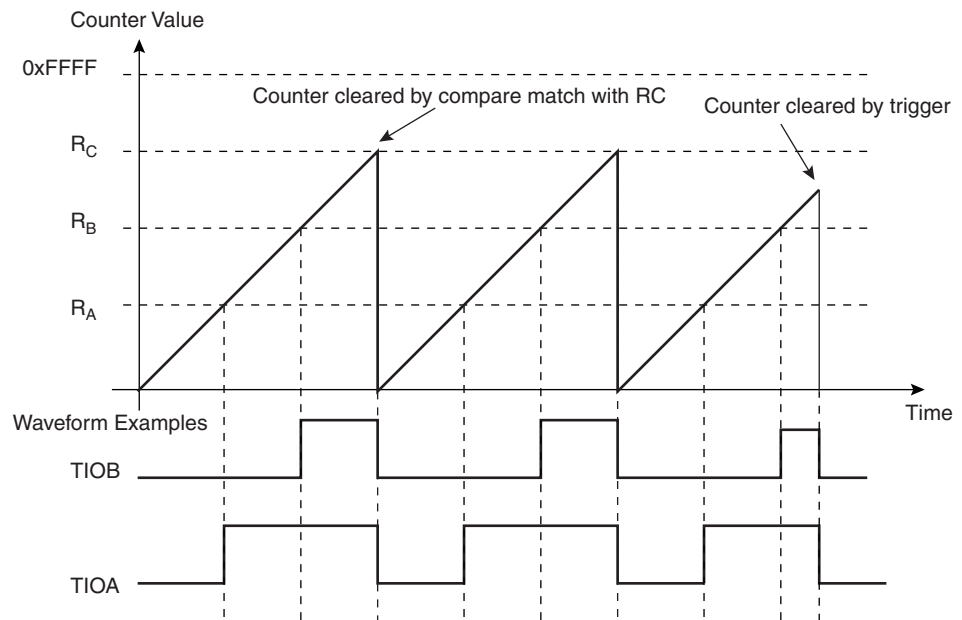

Figure 32-9. WAVSEL = 10 With Trigger



WAVSEL = 01

When WAVSEL = 01, the value of TC_CV is incremented from 0 to 0xFFFF. Once 0xFFFF is reached, the value of TC_CV is decremented to 0, then re-incremented to 0xFFFF and so on. See [Figure 32-10](#).

A trigger such as an external event or a software trigger can modify TC_CV at any time. If a trigger occurs while TC_CV is incrementing, TC_CV then decrements. If a trigger is received while TC_CV is decrementing, TC_CV then increments. See [Figure 32-11](#).

RC Compare cannot be programmed to generate a trigger in this configuration.

At the same time, RC Compare can stop the counter clock (CPCSTOP = 1) and/or disable the counter clock (CPCDIS = 1).

Figure 32-10. WAVSEL = 01 Without Trigger

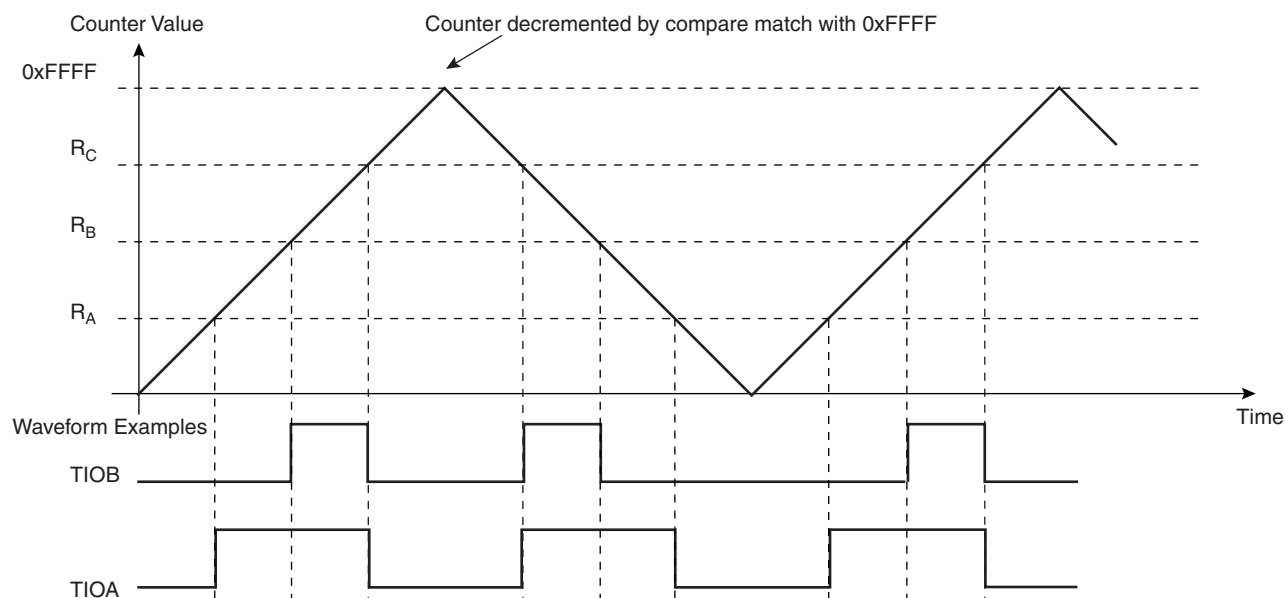
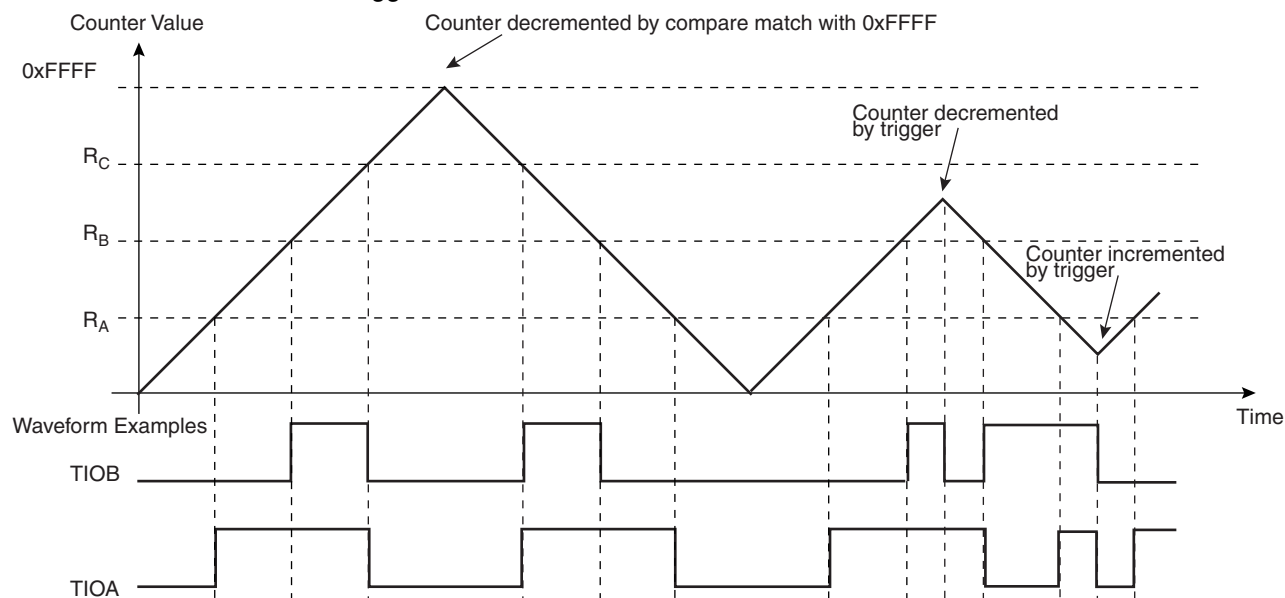

Figure 32-11. WAVSEL = 01 With Trigger



WAVSEL = 11

When WAVSEL = 11, the value of TC_CV is incremented from 0 to RC. Once RC is reached, the value of TC_CV is decremented to 0, then re-incremented to RC and so on. See [Figure 32-12](#).

A trigger such as an external event or a software trigger can modify TC_CV at any time. If a trigger occurs while TC_CV is incrementing, TC_CV then decrements. If a trigger is received while TC_CV is decrementing, TC_CV then increments. See [Figure 32-13](#).

RC Compare can stop the counter clock (CPCSTOP = 1) and/or disable the counter clock (CPCDIS = 1).

Figure 32-12. WAVSEL = 11 Without Trigger

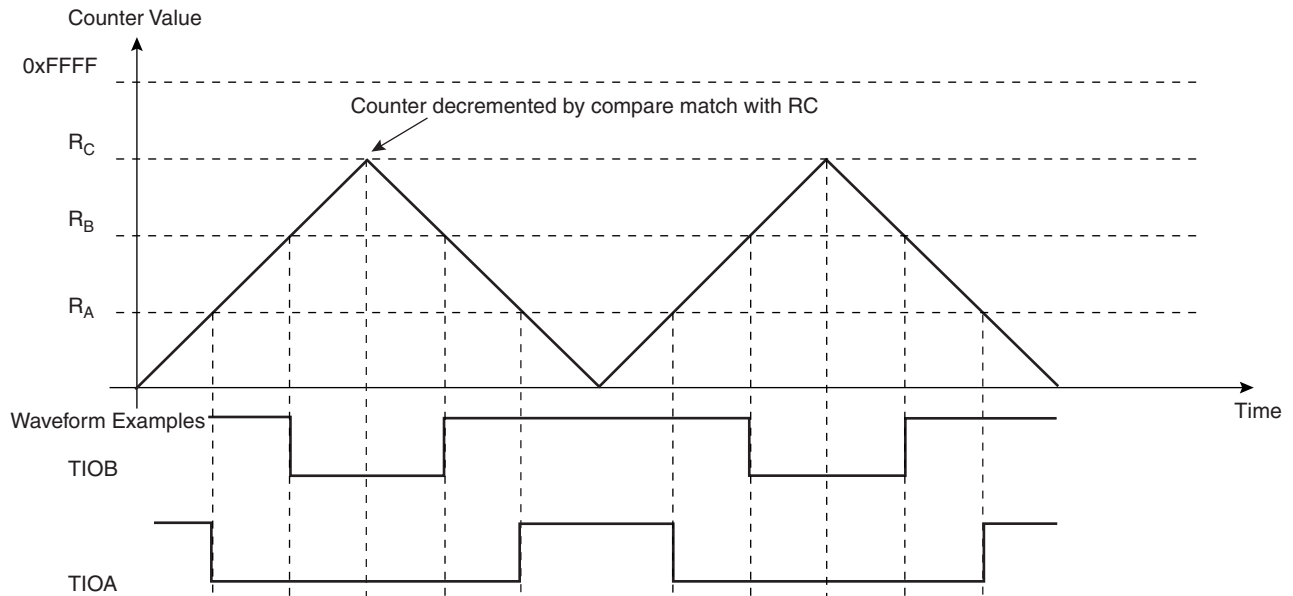
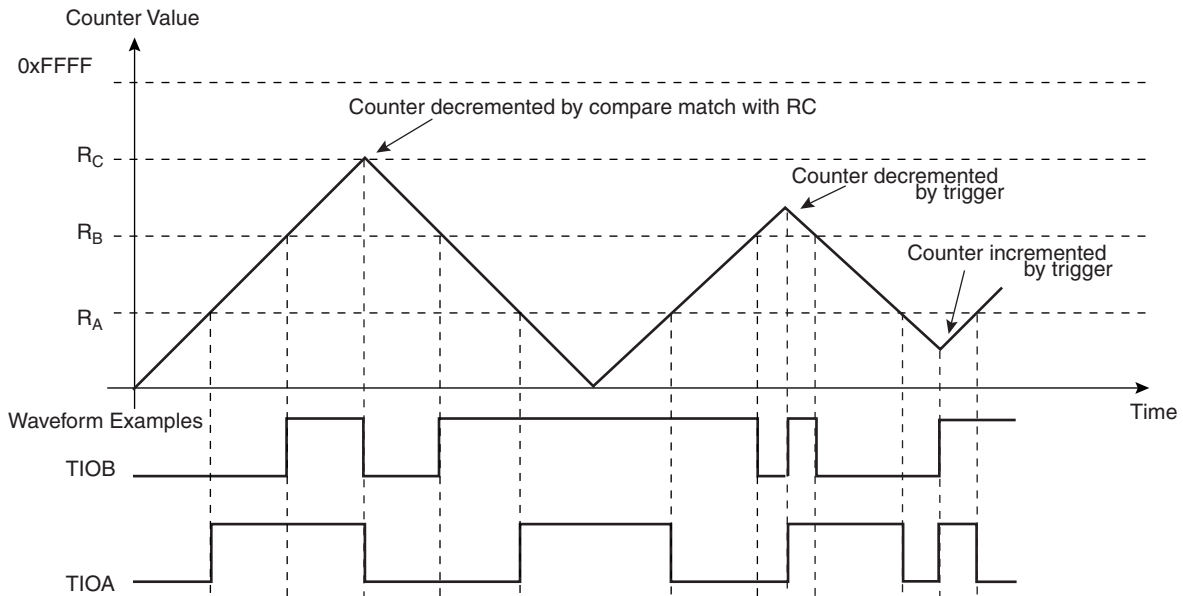

Figure 32-13. WAVSEL = 11 With Trigger



32.6.0.4 External Event/Trigger Conditions

An external event can be programmed to be detected on one of the clock sources (XC0, XC1, XC2) or TIOB. The external event selected can then be used as a trigger.

The parameter EEVT parameter in TC_CMR selects the external trigger. The EEVTEDG parameter defines the trigger edge for each of the possible external triggers (rising, falling or both). If EEVTEDG is cleared (none), no external event is defined.

If TIOB is defined as an external event signal (EEVT = 0), TIOB is no longer used as an output and the TC channel can only generate a waveform on TIOA.

When an external event is defined, it can be used as a trigger by setting bit ENETRГ in TC_CMР.

As in Capture Mode, the SYNC signal and the software trigger are also available as triggers. RC Compare can also be used as a trigger depending on the parameter WAVSEL.

32.6.0.5 *Output Controller*

The output controller defines the output level changes on TIOA and TIOB following an event. TIOB control is used only if TIOB is defined as output (not as an external event).

The following events control TIOA and TIOB: software trigger, external event and RC compare. RA compare controls TIOA and RB compare controls TIOB. Each of these events can be programmed to set, clear or toggle the output as defined in the corresponding parameter in TC_CMР.

32.7 Timer Counter (TC) User Interface

Table 32-3. Timer Counter Global Memory Map

Offset	Channel/Register	Name	Access	Reset Value
0x00	TC Channel 0		See Table 32-4	
0x40	TC Channel 1			
0x80	TC Channel 2			
0xC0	TC Block Control Register	TC_BCR	Write-only	–
0xC4	TC Block Mode Register	TC_BMR	Read/Write	0

TC_BCR (Block Control Register) and TC_BMR (Block Mode Register) control the whole TC block. TC channels are controlled by the registers listed in [Table 32-4](#). The offset of each of the channel registers in [Table 32-4](#) is in relation to the offset of the corresponding channel as mentioned in [Table 32-4](#).

Table 32-4. Timer Counter Channel Memory Map

Offset	Register	Name	Access	Reset Value
0x00	Channel Control Register	TC_CCR	Write-only	–
0x04	Channel Mode Register	TC_CMR	Read/Write	0
0x08	Reserved			–
0x0C	Reserved			–
0x10	Counter Value	TC_CV	Read-only	0
0x14	Register A	TC_RA	Read/Write ⁽¹⁾	0
0x18	Register B	TC_RB	Read/Write ⁽¹⁾	0
0x1C	Register C	TC_RC	Read/Write	0
0x20	Status Register	TC_SR	Read-only	0
0x24	Interrupt Enable Register	TC_IER	Write-only	–
0x28	Interrupt Disable Register	TC_IDR	Write-only	–
0x2C	Interrupt Mask Register	TC_IMR	Read-only	0

Notes: 1. Read only if WAVE = 0

32.7.1 TC Block Control Register

Register Name: TC_BCR

Access Type: Write-only

31	30	29	28	27	26	25	24
-	-	-	-	-	-	-	-
23	22	21	20	19	18	17	16
-	-	-	-	-	-	-	-
15	14	13	12	11	10	9	8
-	-	-	-	-	-	-	-
7	6	5	4	3	2	1	0
-	-	-	-	-	-	-	SYNC

- **SYNC: Synchro Command**

0 = No effect.

1 = Asserts the SYNC signal which generates a software trigger simultaneously for each of the channels.

32.7.2 TC Block Mode Register

Register Name: TC_BMR

Access Type: Read/Write

31	30	29	28	27	26	25	24
–	–	–	–	–	–	–	–
23	22	21	20	19	18	17	16
–	–	–	–	–	–	–	–
15	14	13	12	11	10	9	8
–	–	–	–	–	–	–	–
7	6	5	4	3	2	1	0
–	–	TC2XC2S		TCXC1S		TC0XC0S	

- **TC0XC0S: External Clock Signal 0 Selection**

TC0XC0S		Signal Connected to XC0
0	0	TCLK0
0	1	none
1	0	TIOA1
1	1	TIOA2

- **TC1XC1S: External Clock Signal 1 Selection**

TC1XC1S		Signal Connected to XC1
0	0	TCLK1
0	1	none
1	0	TIOA0
1	1	TIOA2

- **TC2XC2S: External Clock Signal 2 Selection**

TC2XC2S		Signal Connected to XC2
0	0	TCLK2
0	1	none
1	0	TIOA0
1	1	TIOA1

32.7.3 TC Channel Control Register

Register Name: TC_CCR

Access Type: Write-only

31	30	29	28	27	26	25	24
–	–	–	–	–	–	–	–
23	22	21	20	19	18	17	16
–	–	–	–	–	–	–	–
15	14	13	12	11	10	9	8
–	–	–	–	–	–	–	–
7	6	5	4	3	2	1	0
–	–	–	–	–	SWTRG	CLKDIS	CLKEN

- **CLKEN: Counter Clock Enable Command**

0 = No effect.

1 = Enables the clock if CLKDIS is not 1.

- **CLKDIS: Counter Clock Disable Command**

0 = No effect.

1 = Disables the clock.

- **SWTRG: Software Trigger Command**

0 = No effect.

1 = A software trigger is performed: the counter is reset and the clock is started.

32.7.4 TC Channel Mode Register: Capture Mode

Register Name: TC_CMCR

Access Type: Read/Write

31	30	29	28	27	26	25	24
–	–	–	–	–	–	–	–
23	22	21	20	19	18	17	16
–	–	–	–	LDRB		LDRA	
15	14	13	12	11	10	9	8
WAVE = 0	CPCTRG	–	–	–	ABETRG	ETRGEDG	
7	6	5	4	3	2	1	0
LDBDIS	LDBSTOP	BURST		CLKI	TCCLKS		

- **TCCLKS: Clock Selection**

TCCLKS			Clock Selected
0	0	0	TIMER_CLOCK1
0	0	1	TIMER_CLOCK2
0	1	0	TIMER_CLOCK3
0	1	1	TIMER_CLOCK4
1	0	0	TIMER_CLOCK5
1	0	1	XC0
1	1	0	XC1
1	1	1	XC2

- **CLKI: Clock Invert**

0 = Counter is incremented on rising edge of the clock.

1 = Counter is incremented on falling edge of the clock.

- **BURST: Burst Signal Selection**

BURST		
0	0	The clock is not gated by an external signal.
0	1	XC0 is ANDed with the selected clock.
1	0	XC1 is ANDed with the selected clock.
1	1	XC2 is ANDed with the selected clock.

- **LDBSTOP: Counter Clock Stopped with RB Loading**

0 = Counter clock is not stopped when RB loading occurs.

1 = Counter clock is stopped when RB loading occurs.

- **LDBDIS: Counter Clock Disable with RB Loading**

0 = Counter clock is not disabled when RB loading occurs.

1 = Counter clock is disabled when RB loading occurs.

- **ETRGEDG: External Trigger Edge Selection**

ETRGEDG		Edge
0	0	none
0	1	rising edge
1	0	falling edge
1	1	each edge

- **ABETRG: TIOA or TIOB External Trigger Selection**

0 = TIOB is used as an external trigger.

1 = TIOA is used as an external trigger.

- **CPCTRG: RC Compare Trigger Enable**

0 = RC Compare has no effect on the counter and its clock.

1 = RC Compare resets the counter and starts the counter clock.

- **WAVE**

0 = Capture Mode is enabled.

1 = Capture Mode is disabled (Waveform Mode is enabled).

- **LDRA: RA Loading Selection**

LDRA		Edge
0	0	none
0	1	rising edge of TIOA
1	0	falling edge of TIOA
1	1	each edge of TIOA

- **LDRB: RB Loading Selection**

LDRB		Edge
0	0	none
0	1	rising edge of TIOA
1	0	falling edge of TIOA
1	1	each edge of TIOA

32.7.5 TC Channel Mode Register: Waveform Mode

Register Name: TC_CMCR

Access Type: Read/Write

31	30	29	28	27	26	25	24
BSWTRG		BEEVT		BCPC		BCPB	
23	22	21	20	19	18	17	16
ASWTRG		AEEVT		ACPC		ACPA	
15	14	13	12	11	10	9	8
WAVE = 1	WAVSEL		ENETRGR	EEVT		EEVTEDG	
7	6	5	4	3	2	1	0
CPCDIS	CPCSTOP	BURST		CLKI	TCCLKS		

- **TCCLKS: Clock Selection**

TCCLKS			Clock Selected
0	0	0	TIMER_CLOCK1
0	0	1	TIMER_CLOCK2
0	1	0	TIMER_CLOCK3
0	1	1	TIMER_CLOCK4
1	0	0	TIMER_CLOCK5
1	0	1	XC0
1	1	0	XC1
1	1	1	XC2

- **CLKI: Clock Invert**

0 = Counter is incremented on rising edge of the clock.

1 = Counter is incremented on falling edge of the clock.

- **BURST: Burst Signal Selection**

BURST		
0	0	The clock is not gated by an external signal.
0	1	XC0 is ANDed with the selected clock.
1	0	XC1 is ANDed with the selected clock.
1	1	XC2 is ANDed with the selected clock.

- **CPCSTOP: Counter Clock Stopped with RC Compare**

0 = Counter clock is not stopped when counter reaches RC.

1 = Counter clock is stopped when counter reaches RC.

- **CPCDIS: Counter Clock Disable with RC Compare**

0 = Counter clock is not disabled when counter reaches RC.

1 = Counter clock is disabled when counter reaches RC.

- **EEVTEDG: External Event Edge Selection**

EEVTEDG		Edge
0	0	none
0	1	rising edge
1	0	falling edge
1	1	each edge

- **EEVT: External Event Selection**

EEVT		Signal selected as external event	TIOB Direction
0	0	TIOB	input ⁽¹⁾
0	1	XC0	output
1	0	XC1	output
1	1	XC2	output

Note: 1. If TIOB is chosen as the external event signal, it is configured as an input and no longer generates waveforms.

- **ENETRГ: External Event Trigger Enable**

0 = The external event has no effect on the counter and its clock. In this case, the selected external event only controls the TIOA output.

1 = The external event resets the counter and starts the counter clock.

- **WAVSEL: Waveform Selection**

WAVSEL		Effect
0	0	UP mode without automatic trigger on RC Compare
1	0	UP mode with automatic trigger on RC Compare
0	1	UPDOWN mode without automatic trigger on RC Compare
1	1	UPDOWN mode with automatic trigger on RC Compare

- **WAVE = 1**

0 = Waveform Mode is disabled (Capture Mode is enabled).

1 = Waveform Mode is enabled.

- **ACPA: RA Compare Effect on TIOA**

ACPA		Effect
0	0	none
0	1	set
1	0	clear
1	1	toggle

- **ACPC: RC Compare Effect on TIOA**

ACPC		Effect
0	0	none
0	1	set
1	0	clear
1	1	toggle

- **AEEVT: External Event Effect on TIOA**

AEEVT		Effect
0	0	none
0	1	set
1	0	clear
1	1	toggle

- **ASWTRG: Software Trigger Effect on TIOA**

ASWTRG		Effect
0	0	none
0	1	set
1	0	clear
1	1	toggle

- **BCPB: RB Compare Effect on TIOB**

BCPB		Effect
0	0	none
0	1	set
1	0	clear
1	1	toggle

- **BCPC: RC Compare Effect on TIOB**

BCPC		Effect
0	0	none
0	1	set
1	0	clear
1	1	toggle

• **BEEVT: External Event Effect on TIOB**

BEEVT		Effect
0	0	none
0	1	set
1	0	clear
1	1	toggle

• **BSWTRG: Software Trigger Effect on TIOB**

BSWTRG		Effect
0	0	none
0	1	set
1	0	clear
1	1	toggle

32.7.6 TC Counter Value Register

Register Name: TC_CV

Access Type: Read-only

31	30	29	28	27	26	25	24
–	–	–	–	–	–	–	–
23	22	21	20	19	18	17	16
–	–	–	–	–	–	–	–
15	14	13	12	11	10	9	8
CV							
7	6	5	4	3	2	1	0
CV							

- **CV: Counter Value**

CV contains the counter value in real time.

32.7.7 TC Register A

Register Name: TC_RA

Access Type: Read-only if WAVE = 0, Read/Write if WAVE = 1

31	30	29	28	27	26	25	24
–	–	–	–	–	–	–	–
23	22	21	20	19	18	17	16
–	–	–	–	–	–	–	–
15	14	13	12	11	10	9	8
RA							
7	6	5	4	3	2	1	0
RA							

- **RA: Register A**

RA contains the Register A value in real time.

32.7.8 TC Register B

Register Name: TC_RB

Access Type: Read-only if WAVE = 0, Read/Write if WAVE = 1

31	30	29	28	27	26	25	24
-	-	-	-	-	-	-	-
23	22	21	20	19	18	17	16
-	-	-	-	-	-	-	-
15	14	13	12	11	10	9	8
RB							
7	6	5	4	3	2	1	0
RB							

- **RB: Register B**

RB contains the Register B value in real time.

32.7.9 TC Register C

Register Name: TC_RC

Access Type: Read/Write

31	30	29	28	27	26	25	24
-	-	-	-	-	-	-	-
23	22	21	20	19	18	17	16
-	-	-	-	-	-	-	-
15	14	13	12	11	10	9	8
RC							
7	6	5	4	3	2	1	0
RC							

- **RC: Register C**

RC contains the Register C value in real time.

32.7.10 TC Status Register

Register Name: TC_SR

Access Type: Read-only

31	30	29	28	27	26	25	24
–	–	–	–	–	–	–	–
23	22	21	20	19	18	17	16
–	–	–	–	–	MTIOB	MTIOA	CLKSTA
15	14	13	12	11	10	9	8
–	–	–	–	–	–	–	–
7	6	5	4	3	2	1	0
ETRGS	LDRBS	LDRAS	CPCS	CPBS	CPAS	LOVRS	COVFS

- **COVFS: Counter Overflow Status**

0 = No counter overflow has occurred since the last read of the Status Register.

1 = A counter overflow has occurred since the last read of the Status Register.

- **LOVRS: Load Overrun Status**

0 = Load overrun has not occurred since the last read of the Status Register or WAVE = 1.

1 = RA or RB have been loaded at least twice without any read of the corresponding register since the last read of the Status Register, if WAVE = 0.

- **CPAS: RA Compare Status**

0 = RA Compare has not occurred since the last read of the Status Register or WAVE = 0.

1 = RA Compare has occurred since the last read of the Status Register, if WAVE = 1.

- **CPBS: RB Compare Status**

0 = RB Compare has not occurred since the last read of the Status Register or WAVE = 0.

1 = RB Compare has occurred since the last read of the Status Register, if WAVE = 1.

- **CPCS: RC Compare Status**

0 = RC Compare has not occurred since the last read of the Status Register.

1 = RC Compare has occurred since the last read of the Status Register.

- **LDRAS: RA Loading Status**

0 = RA Load has not occurred since the last read of the Status Register or WAVE = 1.

1 = RA Load has occurred since the last read of the Status Register, if WAVE = 0.

- **LDRBS: RB Loading Status**

0 = RB Load has not occurred since the last read of the Status Register or WAVE = 1.

1 = RB Load has occurred since the last read of the Status Register, if WAVE = 0.

- **ETRGS: External Trigger Status**

0 = External trigger has not occurred since the last read of the Status Register.

1 = External trigger has occurred since the last read of the Status Register.

- **CLKSTA: Clock Enabling Status**

0 = Clock is disabled.

1 = Clock is enabled.

- **MTIOA: TIOA Mirror**

0 = TIOA is low. If WAVE = 0, this means that TIOA pin is low. If WAVE = 1, this means that TIOA is driven low.

1 = TIOA is high. If WAVE = 0, this means that TIOA pin is high. If WAVE = 1, this means that TIOA is driven high.

- **MTIOB: TIOB Mirror**

0 = TIOB is low. If WAVE = 0, this means that TIOB pin is low. If WAVE = 1, this means that TIOB is driven low.

1 = TIOB is high. If WAVE = 0, this means that TIOB pin is high. If WAVE = 1, this means that TIOB is driven high.

32.7.11 TC Interrupt Enable Register

Register Name: TC_IER

Access Type: Write-only

31	30	29	28	27	26	25	24
–	–	–	–	–	–	–	–
23	22	21	20	19	18	17	16
–	–	–	–	–	–	–	–
15	14	13	12	11	10	9	8
–	–	–	–	–	–	–	–
7	6	5	4	3	2	1	0
ETRGS	LDRBS	LDRAS	CPCS	CPBS	CPAS	LOVRS	COVFS

- **COVFS: Counter Overflow**

0 = No effect.

1 = Enables the Counter Overflow Interrupt.

- **LOVRS: Load Overrun**

0 = No effect.

1 = Enables the Load Overrun Interrupt.

- **CPAS: RA Compare**

0 = No effect.

1 = Enables the RA Compare Interrupt.

- **CPBS: RB Compare**

0 = No effect.

1 = Enables the RB Compare Interrupt.

- **CPCS: RC Compare**

0 = No effect.

1 = Enables the RC Compare Interrupt.

- **LDRAS: RA Loading**

0 = No effect.

1 = Enables the RA Load Interrupt.

- **LDRBS: RB Loading**

0 = No effect.

1 = Enables the RB Load Interrupt.

- **ETRGS: External Trigger**

0 = No effect.

1 = Enables the External Trigger Interrupt.

32.7.12 TC Interrupt Disable Register

Register Name: TC_IDR

Access Type: Write-only

31	30	29	28	27	26	25	24
-	-	-	-	-	-	-	-
23	22	21	20	19	18	17	16
-	-	-	-	-	-	-	-
15	14	13	12	11	10	9	8
-	-	-	-	-	-	-	-
7	6	5	4	3	2	1	0
ETRGS	LDRBS	LDRAS	CPCS	CPBS	CPAS	LOVRS	COVFS

- **COVFS: Counter Overflow**

0 = No effect.

1 = Disables the Counter Overflow Interrupt.

- **LOVRS: Load Overrun**

0 = No effect.

1 = Disables the Load Overrun Interrupt (if WAVE = 0).

- **CPAS: RA Compare**

0 = No effect.

1 = Disables the RA Compare Interrupt (if WAVE = 1).

- **CPBS: RB Compare**

0 = No effect.

1 = Disables the RB Compare Interrupt (if WAVE = 1).

- **CPCS: RC Compare**

0 = No effect.

1 = Disables the RC Compare Interrupt.

- **LDRAS: RA Loading**

0 = No effect.

1 = Disables the RA Load Interrupt (if WAVE = 0).

- **LDRBS: RB Loading**

0 = No effect.

1 = Disables the RB Load Interrupt (if WAVE = 0).

- **ETRGS: External Trigger**

0 = No effect.

1 = Disables the External Trigger Interrupt.

32.7.13 TC Interrupt Mask Register

Register Name: TC_IMR

Access Type: Read-only

31	30	29	28	27	26	25	24
–	–	–	–	–	–	–	–
23	22	21	20	19	18	17	16
–	–	–	–	–	–	–	–
15	14	13	12	11	10	9	8
–	–	–	–	–	–	–	–
7	6	5	4	3	2	1	0
ETRGS	LDRBS	LDRAS	CPCS	CPBS	CPAS	LOVRS	COVFS

- **COVFS: Counter Overflow**

0 = The Counter Overflow Interrupt is disabled.

1 = The Counter Overflow Interrupt is enabled.

- **LOVRS: Load Overrun**

0 = The Load Overrun Interrupt is disabled.

1 = The Load Overrun Interrupt is enabled.

- **CPAS: RA Compare**

0 = The RA Compare Interrupt is disabled.

1 = The RA Compare Interrupt is enabled.

- **CPBS: RB Compare**

0 = The RB Compare Interrupt is disabled.

1 = The RB Compare Interrupt is enabled.

- **CPCS: RC Compare**

0 = The RC Compare Interrupt is disabled.

1 = The RC Compare Interrupt is enabled.

- **LDRAS: RA Loading**

0 = The Load RA Interrupt is disabled.

1 = The Load RA Interrupt is enabled.

- **LDRBS: RB Loading**

0 = The Load RB Interrupt is disabled.

1 = The Load RB Interrupt is enabled.

- **ETRGS: External Trigger**

0 = The External Trigger Interrupt is disabled.

1 = The External Trigger Interrupt is enabled.



33. MultiMedia Card Interface (MCI)

33.1 Description

The MultiMedia Card Interface (MCI) supports the MultiMedia Card (MMC) Specification V2.2 and the SD Memory Card Specification V1.0.

The MCI includes a command register, response registers, data registers, timeout counters and error detection logic that automatically handle the transmission of commands and, when required, the reception of the associated responses and data with a limited processor overhead.

The MCI supports stream, block and multi-block data read and write, and is compatible with the Peripheral DMA Controller (PDC) channels, minimizing processor intervention for large buffer transfers.

The MCI operates at a rate of up to Master Clock divided by 2 and supports the interfacing of 1 slot(s). Each slot may be used to interface with a MultiMediaCard bus (up to 30 Cards) or with a SD Memory Card. Only one slot can be selected at a time (slots are multiplexed). A bit field in the SD Card Register performs this selection.

The SD Memory Card communication is based on a 9-pin interface (clock, command, four data and three power lines) and the MultiMedia Card on a 7-pin interface (clock, command, one data, three power lines and one reserved for future use).

The SD Memory Card interface also supports MultiMedia Card operations. The main differences between SD and MultiMedia Cards are the initialization process and the bus topology.

33.2 Block Diagram

Figure 33-1. Block Diagram

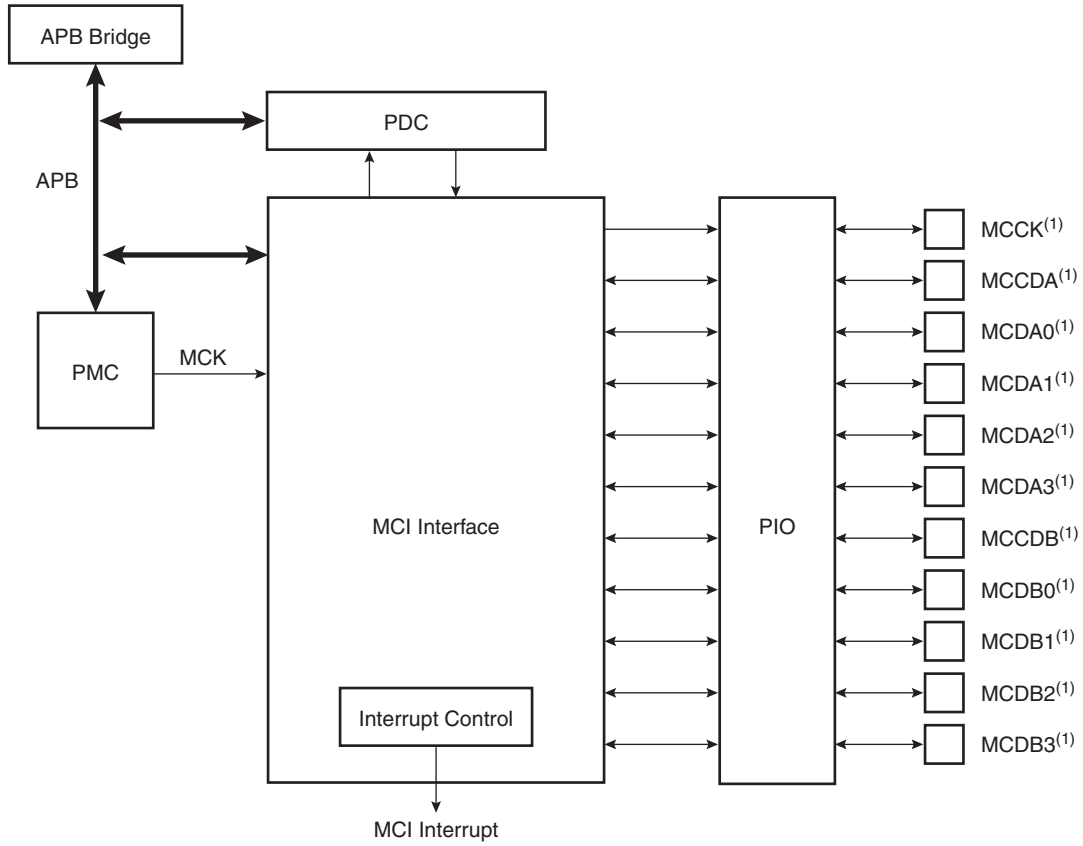

Note: 1. When several MCIs (x MCI) are embedded in a product, MCCK refers to MCix_CK, MCCDA to MCix_CDA, MCCDB to MCix_CDB, MCDAy to MCix_DAy, MCDBy to MCix_DBy.

33.3 Application Block Diagram

Figure 33-2. Application Block Diagram

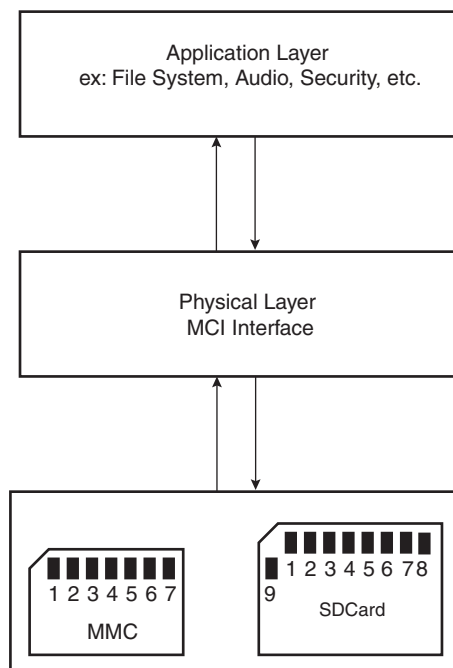

33.4 Pin Name List

Table 33-1. I/O Lines Description

Pin Name ⁽²⁾	Pin Description	Type ⁽¹⁾	Comments
MCCDA/MCCDB	Command/response	I/O/PP/OD	CMD of an MMC or SDCard
MCCK	Clock	I/O	CLK of an MMC or SD Card
MCDA0 - MCDA3	Data 0..3 of Slot A	I/O/PP	DAT0 of an MMC DAT[0..3] of an SD Card
MCDB0 - MCDB3	Data 0..3 of Slot B	I/O/PP	DAT0 of an MMC DAT[0..3] of an SD Card

Notes: 1. I: Input, O: Output, PP: Push/Pull, OD: Open Drain.

2. When several MCI (x MCI) are embedded in a product, MCCK refers to MCIx_CK, MCCDA to MCIx_CDA, MCCDB to MCIx_CDB, MCDAy to MCIx_DAy, MCDBy to MCIx_DBy.

33.5 Product Dependencies

33.5.1 I/O Lines

The pins used for interfacing the MultiMedia Cards or SD Cards may be multiplexed with PIO lines. The programmer must first program the PIO controllers to assign the peripheral functions to MCI pins.

33.5.2 Power Management

The MCI may be clocked through the Power Management Controller (PMC), so the programmer must first configure the PMC to enable the MCI clock.

33.5.3 Interrupt

The MCI interface has an interrupt line connected to the Advanced Interrupt Controller (AIC). Handling the MCI interrupt requires programming the AIC before configuring the MCI.

33.6 Bus Topology

Figure 33-3. Multimedia Memory Card Bus Topology

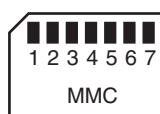

The MultiMedia Card communication is based on a 7-pin serial bus interface. It has three communication lines and four supply lines.

Table 33-2. Bus Topology

Pin Number	Name	Type ⁽¹⁾	Description	MCI Pin Name ⁽²⁾ (Slot z)
1	RSV	NC	Not connected	-
2	CMD	I/O/PP/OD	Command/response	MCCDz
3	VSS1	S	Supply voltage ground	VSS
4	VDD	S	Supply voltage	VDD
5	CLK	I/O	Clock	MCKK
6	VSS2	S	Supply voltage ground	VSS
7	DAT[0]	I/O/PP	Data 0	MCDz0

- Notes:
1. I: Input, O: Output, PP: Push/Pull, OD: Open Drain.
 2. When several MCI (x MCI) are embedded in a product, MCKK refers to MCix_CK, MCCDA to MCix_CDA, MCCDB to MCix_CDB, MCDAy to MCix_DAy, MCDBy to MCix_DBy.

Figure 33-4. MMC Bus Connections (One Slot)

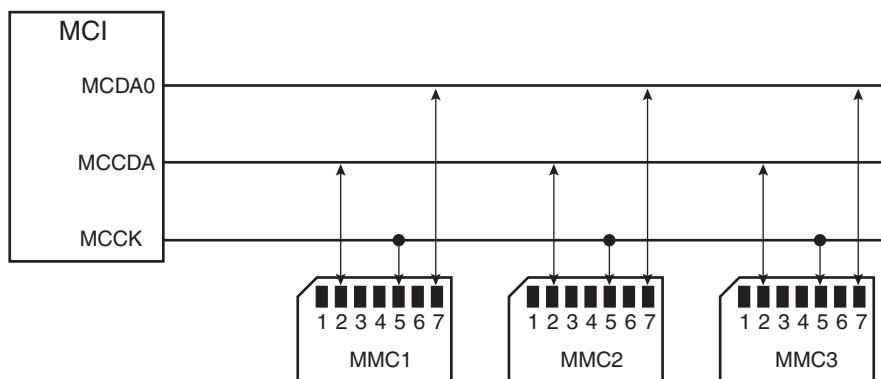

Note: When several MCIs (x MCI) are embedded in a product, MCK refers to MCIx_CK, MCCDA to MCIx_CDA, MCDAy to MCIx_DAy.

Figure 33-5. SD Memory Card Bus Topology

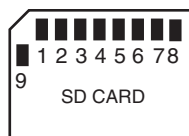

The SD Memory Card bus includes the signals listed in [Table 33-3](#).

Table 33-3. SD Memory Card Bus Signals

Pin Number	Name	Type ⁽¹⁾	Description	MCI Pin Name ⁽²⁾ (Slot z)
1	CD/DAT[3]	I/O/PP	Card detect/ Data line Bit 3	MCDz3
2	CMD	PP	Command/response	MCCDz
3	VSS1	S	Supply voltage ground	VSS
4	VDD	S	Supply voltage	VDD
5	CLK	I/O	Clock	MCK
6	VSS2	S	Supply voltage ground	VSS
7	DAT[0]	I/O/PP	Data line Bit 0	MCDz0
8	DAT[1]	I/O/PP	Data line Bit 1	MCDz1
9	DAT[2]	I/O/PP	Data line Bit 2	MCDz2

- Notes:
1. I: input, O: output, PP: Push Pull, OD: Open Drain.
 2. When several MCIs (x MCI) are embedded in a product, MCK refers to MCIx_CK, MCCDA to MCIx_CDA, MCCDB to MCIx_CDB, MCDAy to MCIx_DAy, MCDBy to MCIx_DBy.

Figure 33-6. SD Card Bus Connections with One Slot

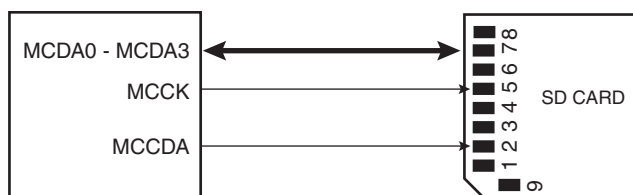

Note: When several MCIs (x MCI) are embedded in a product, MCCDA refers to MCIx_CDA, MCDAy to MCIx_DAy.

Figure 33-7. SD Card Bus Connections with Two Slots

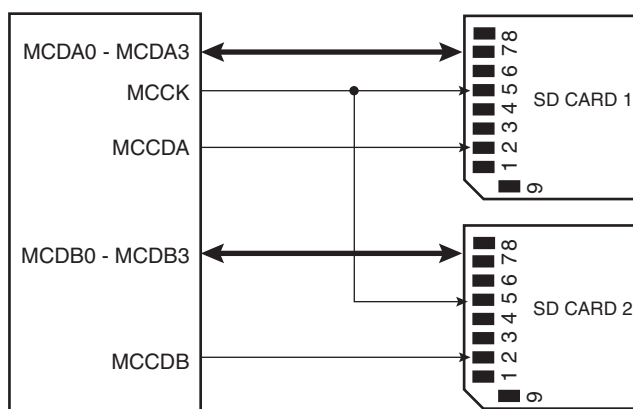

Note: When several MCIs (x MCI) are embedded in a product, MCCK refers to MCIx_CK, MCCDA to MCIx_CDA, MCDAy to MCIx_DAy, MCCDB to MCIx_CDB, MCDBy to MCIx_DBy.

Figure 33-8. Mixing MultiMedia and SD Memory Cards with Two Slots

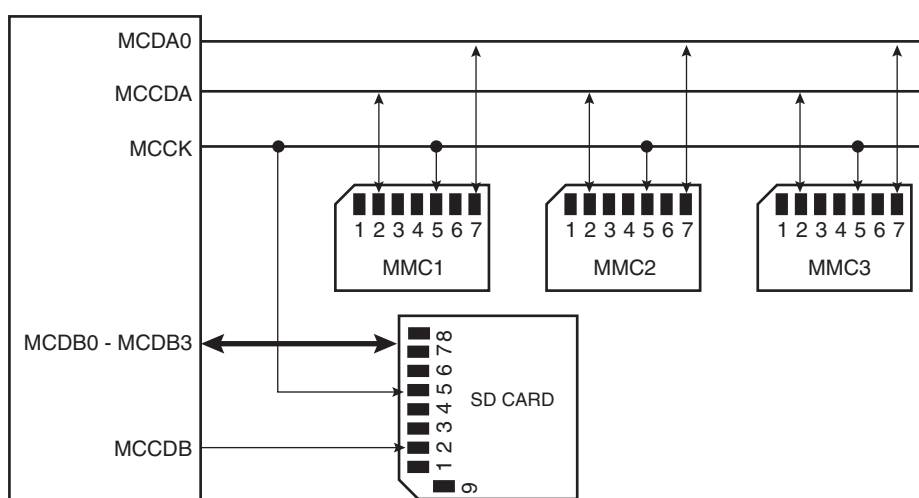

Note: When several MCIs (x MCI) are embedded in a product, MCCK refers to MCIx_CK, MCCDA to MCIx_CDA, MCDAy to MCIx_DAy, MCCDB to MCIx_CDB, MCDBy to MCIx_DBy.

When the MCI is configured to operate with SD memory cards, the width of the data bus can be selected in the MCI_SDCR register. Clearing the SDCBUS bit in this register means that the

width is one bit; setting it means that the width is four bits. In the case of multimedia cards, only the data line 0 is used. The other data lines can be used as independent PIOs.

33.7 MultiMedia Card Operations

After a power-on reset, the cards are initialized by a special message-based MultiMedia Card bus protocol. Each message is represented by one of the following tokens:

- **Command:** A command is a token that starts an operation. A command is sent from the host either to a single card (addressed command) or to all connected cards (broadcast command). A command is transferred serially on the CMD line.
- **Response:** A response is a token which is sent from an addressed card or (synchronously) from all connected cards to the host as an answer to a previously received command. A response is transferred serially on the CMD line.
- **Data:** Data can be transferred from the card to the host or vice versa. Data is transferred via the data line.

Card addressing is implemented using a session address assigned during the initialization phase by the bus controller to all currently connected cards. Their unique CID number identifies individual cards.

The structure of commands, responses and data blocks is described in the MultiMedia-Card System Specification. See also [Table 33-4 on page 526](#).

MultiMediaCard bus data transfers are composed of these tokens.

There are different types of operations. Addressed operations always contain a command and a response token. In addition, some operations have a data token; the others transfer their information directly within the command or response structure. In this case, no data token is present in an operation. The bits on the DAT and the CMD lines are transferred synchronous to the clock MCI Clock.

Two types of data transfer commands are defined:

- **Sequential commands:** These commands initiate a continuous data stream. They are terminated only when a stop command follows on the CMD line. This mode reduces the command overhead to an absolute minimum.
- **Block-oriented commands:** These commands send a data block succeeded by CRC bits.

Both read and write operations allow either single or multiple block transmission. A multiple block transmission is terminated when a stop command follows on the CMD line similarly to the sequential read.

The MCI provides a set of registers to perform the entire range of MultiMedia Card operations.

33.7.1 Command - Response Operation

After reset, the MCI is disabled and becomes valid after setting the MCIEN bit in the MCI_CR Control Register.

The PWSEN bit saves power by dividing the MCI clock by $2^{\text{PWSDIV}} + 1$ when the bus is inactive.

The command and the response of the card are clocked out with the rising edge of the MCI Clock.

All the timings for MultiMedia Card are defined in the MultiMediaCard System Specification.

The two bus modes (open drain and push/pull) needed to process all the operations are defined in the MCI command register. The MCI_CMDR allows a command to be carried out.

For example, to perform an ALL_SEND_CID command:

Host Command					N _{ID} Cycles			CID						
CMD	S	T	Content	CRC	E	Z	*****	Z	S	T	Content	Z	Z	Z

The command ALL_SEND_CID and the fields and values for the MCI_CMDR Control Register are described in [Table 33-4](#) and [Table 33-5](#).

Table 33-4. ALL_SEND_CID Command Description

CMD Index	Type	Argument	Resp	Abbreviation	Command Description
CMD2	bcr	[31:0] stuff bits	R2	ALL_SEND_CID	Asks all cards to send their CID numbers on the CMD line

Note: bcr means broadcast command with response.

Table 33-5. Fields and Values for MCI_CMDR Command Register

Field	Value
CMDNB (command number)	2 (CMD2)
RSPTYP (response type)	2 (R2: 136 bits response)
SPCMD (special command)	0 (not a special command)
OPCMD (open drain command)	1
MAXLAT (max latency for command to response)	0 (NID cycles ==> 5 cycles)
TRCMD (transfer command)	0 (No transfer)
TRDIR (transfer direction)	X (available only in transfer command)
TRTYP (transfer type)	X (available only in transfer command)

The MCI_ARGR contains the argument field of the command.

To send a command, the user must perform the following steps:

- Fill the argument register (MCI_ARGR) with the command argument.
- Set the command register (MCI_CMDR) (see [Table 33-5](#)).

The command is sent immediately after writing the command register. The status bit CMDRDY in the status register (MCI_SR) is asserted when the command is completed. If the command requires a response, it can be read in the MCI response register (MCI_RSPR). The response size can be from 48 bits up to 136 bits depending on the command. The MCI embeds an error detection to prevent any corrupted data during the transfer.

The following flowchart shows how to send a command to the card and read the response if needed. In this example, the status register bits are polled but setting the appropriate bits in the interrupt enable register (MCI_IER) allows using an interrupt method.

Figure 33-9. Command/Response Functional Flow Diagram

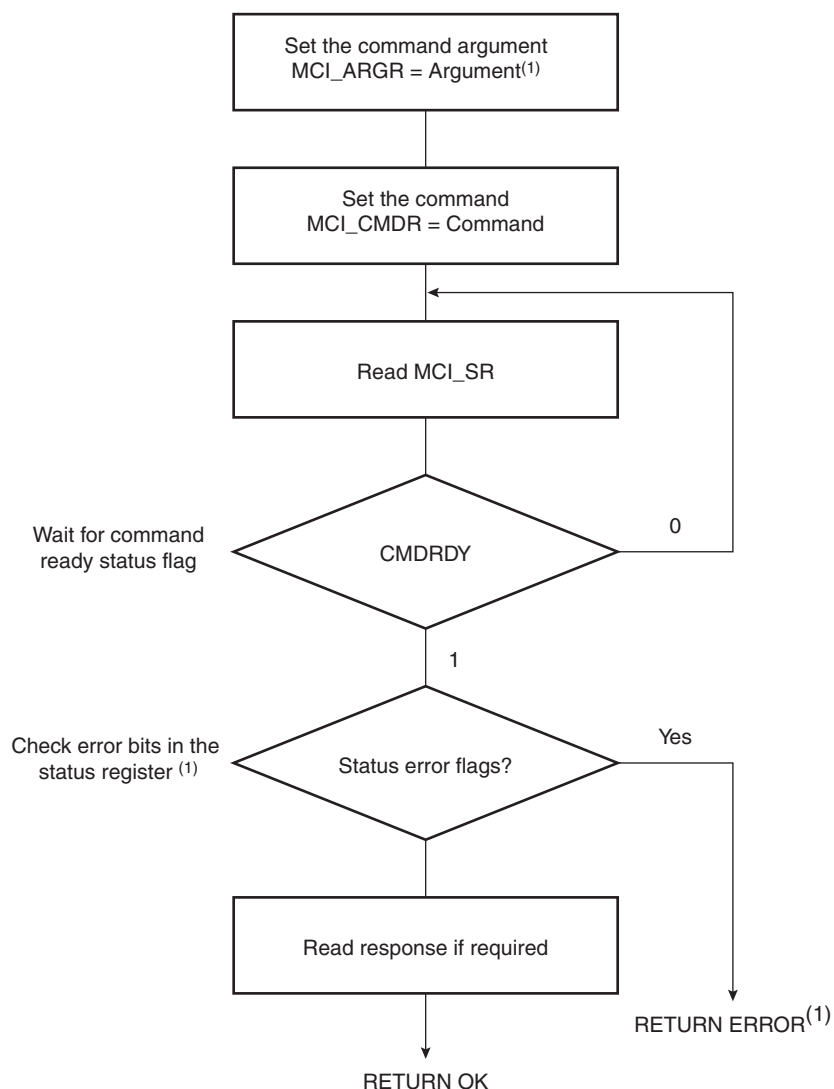

Note: 1. If the command is SEND_OP_COND, the CRC error flag is always present (refer to R3 response in the MultiMedia Card specification).

33.7.2 Data Transfer Operation

The MultiMedia Card allows several read/write operations (single block, multiple blocks, stream, etc.). These kind of transfers can be selected setting the Transfer Type (TRTYP) field in the MCI Command Register (MCI_CMDR).

These operations can be done using the features of the Peripheral DMA Controller (PDC). If the PDCMODE bit is set in MCI_MR, then all reads and writes use the PDC facilities.

In all cases, the block length (BLKLEN field) must be defined in the mode register MCI_MR. This field determines the size of the data block.

33.7.3 Read Operation

The following flowchart shows how to read a single block with or without use of PDC facilities. In this example (see Figure 33-10), a polling method is used to wait for the end of read. Similarly,



the user can configure the interrupt enable register (MCI_IER) to trigger an interrupt at the end of read.

Figure 33-10. Read Functional Flow Diagram

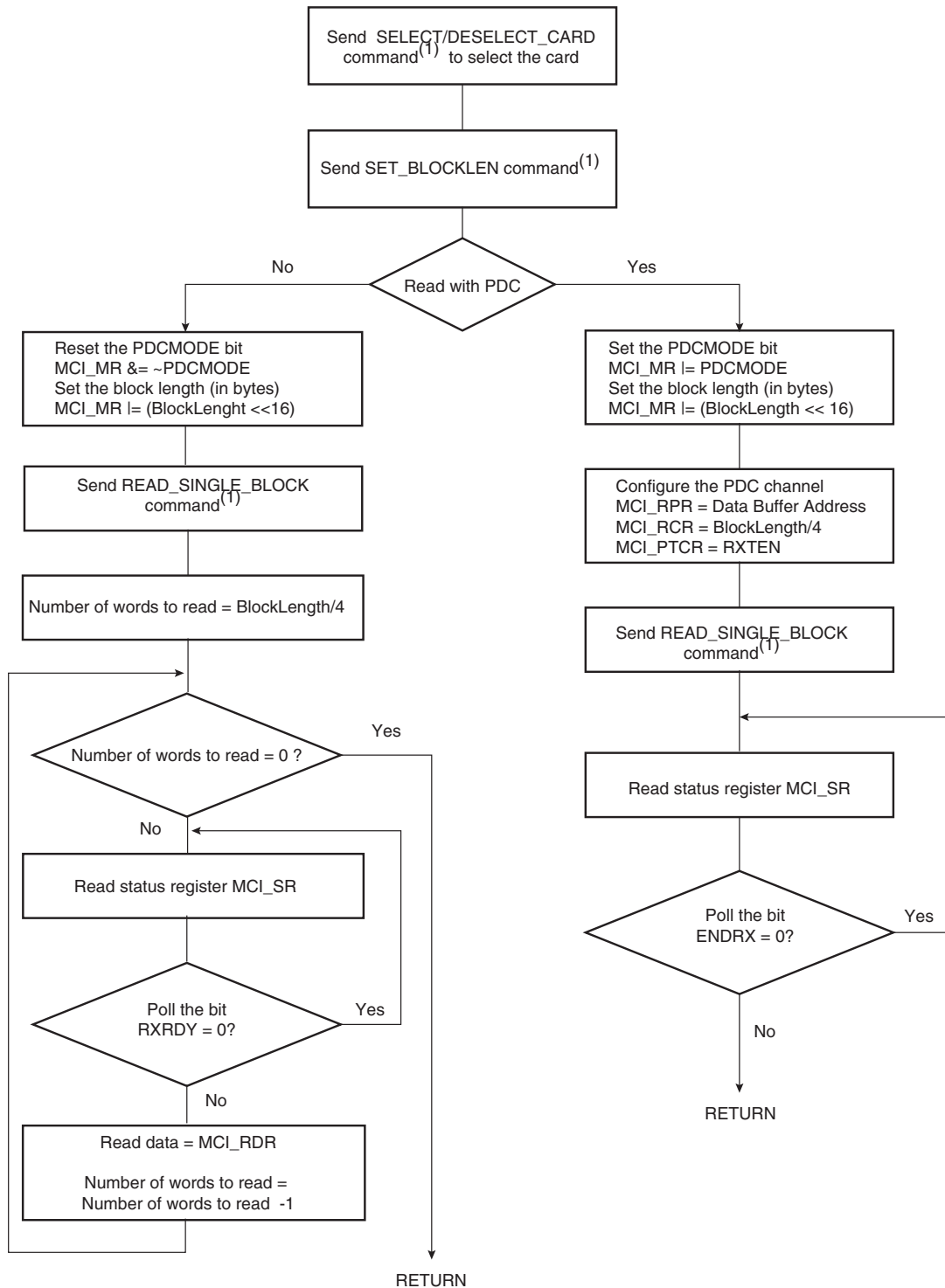

Note: 1. It is assumed that this command has been correctly sent (see Figure 33-9).

33.7.4 Write Operation

In write operation, the MCI Mode Register (MCI_MR) is used to define the padding value when writing non-multiple block size. If the bit PDCPADV is 0, then 0x00 value is used when padding data, otherwise 0xFF is used.

If set, the bit PDCMODE enables PDC transfer.

The following flowchart shows how to write a single block with or without use of PDC facilities (see [Figure 33-11](#)). Polling or interrupt method can be used to wait for the end of write according to the contents of the Interrupt Mask Register (MCI_IMR).

Figure 33-11. Write Functional Flow Diagram

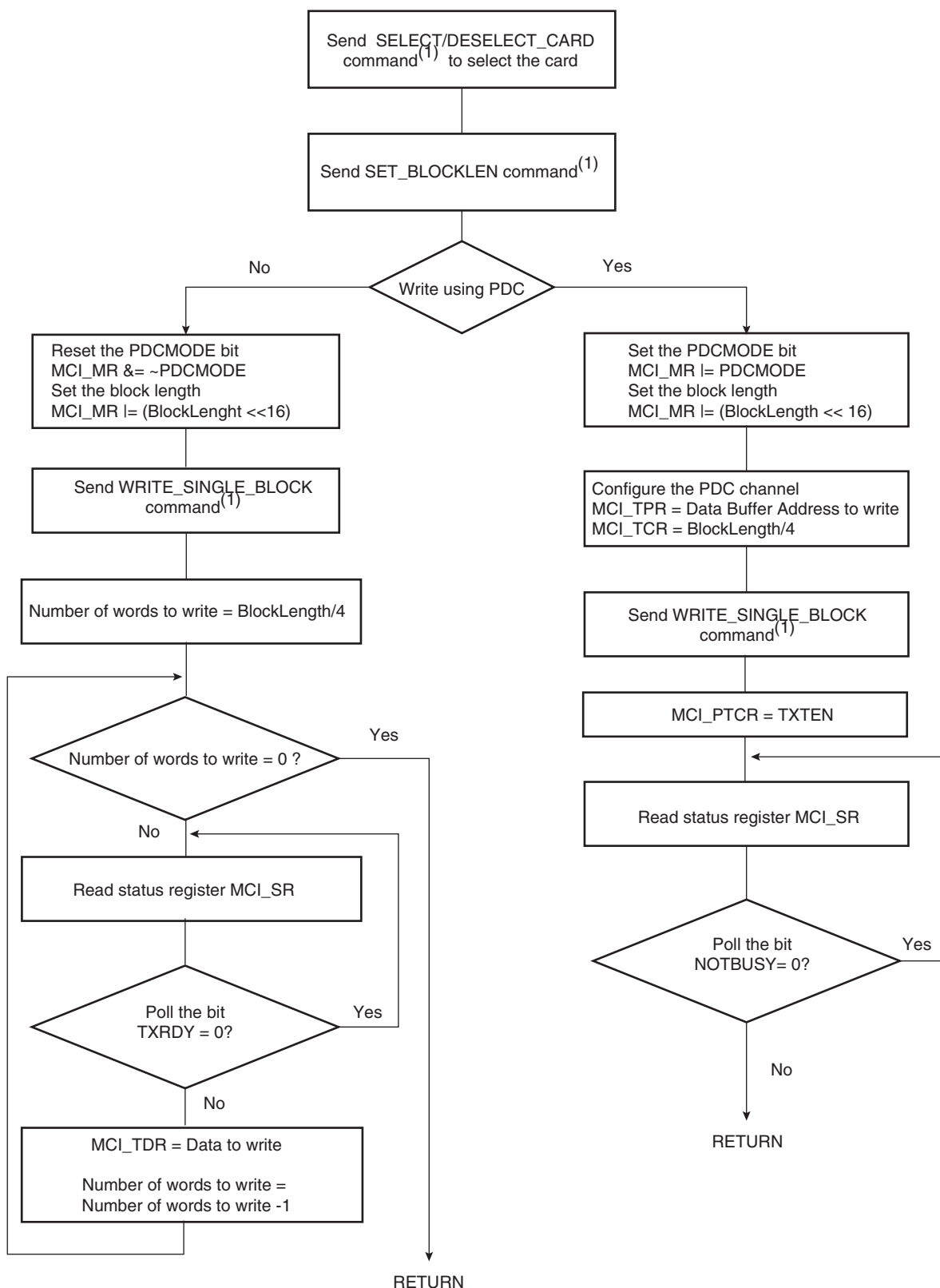

Note: 1. It is assumed that this command has been correctly sent (see Figure 33-9).

The following flowchart shows how to manage a multiple write block transfer with the PDC (see [Figure 33-12](#)). Polling or interrupt method can be used to wait for the end of write according to the contents of the Interrupt Mask Register (MCI_IMR).

Figure 33-12. Multiple Write Functional Flow Diagram

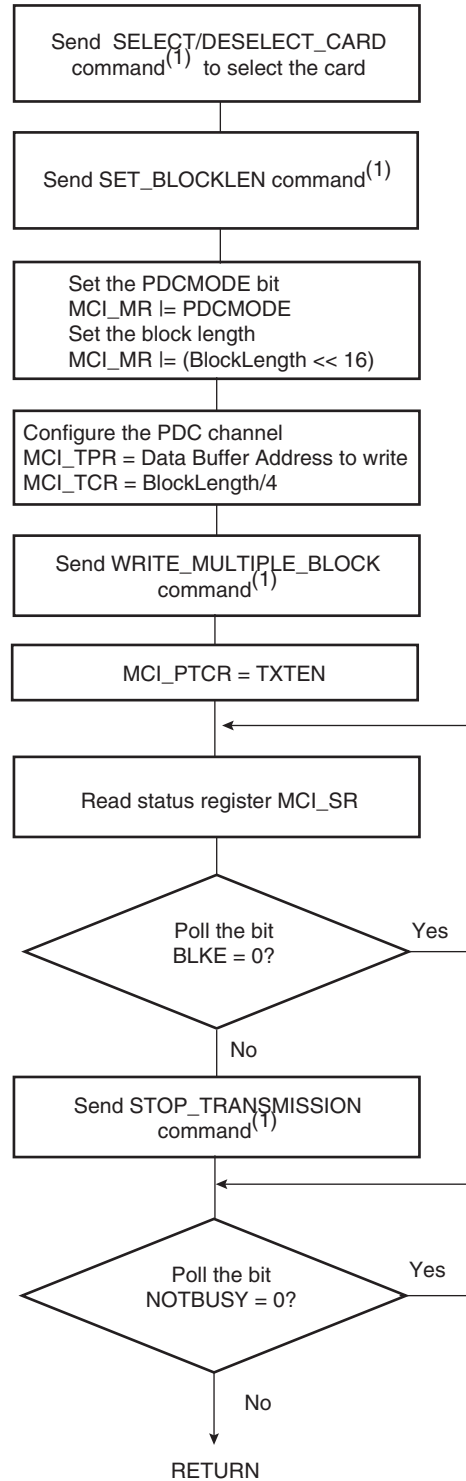

Note: 1. It is assumed that this command has been correctly sent (see [Figure 33-9](#)).

33.8 SD Card Operations

The MultiMedia Card Interface allows processing of SD Memory (Secure Digital Memory Card) Card commands.

SD cards are based on the Multi Media Card (MMC) format, but are physically slightly thicker and feature higher data transfer rates, a lock switch on the side to prevent accidental overwriting and security features. The physical form factor, pin assignment and data transfer protocol are forward-compatible with the MultiMedia Card with some additions. SD is covered by numerous patents and trademarks, and licensing is only available through the Secure Digital Card Association.

The SD Card communication is based on a 9-pin interface (Clock, Command, 4 x Data and 3 x Power lines). The communication protocol is defined as a part of this specification. The main difference between the SD Card and the MultiMedia Card is the initialization process.

The SD Card Register (MCI_SDCCR) allows selection of the Card Slot and the data bus width.

The SD Card bus allows dynamic configuration of the number of data lines. After power up, by default, the SD Card uses only DAT0 for data transfer. After initialization, the host can change the bus width (number of active data lines).

33.9 MultiMedia Card Interface (MCI) User Interface

Table 33-6. Register Mapping

Offset	Register	Register Name	Read/Write	Reset
0x00	Control Register	MCI_CR	Write	–
0x04	Mode Register	MCI_MR	Read/write	0x0
0x08	Data Timeout Register	MCI_DTOR	Read/write	0x0
0x0C	SD Card Register	MCI_SDCR	Read/write	0x0
0x10	Argument Register	MCI_ARGR	Read/write	0x0
0x14	Command Register	MCI_CMDR	Write	–
0x18 - 0x1C	Reserved	–	–	–
0x20	Response Register ⁽¹⁾	MCI_RSPR	Read	0x0
0x24	Response Register ⁽¹⁾	MCI_RSPR	Read	0x0
0x28	Response Register ⁽¹⁾	MCI_RSPR	Read	0x0
0x2C	Response Register ⁽¹⁾	MCI_RSPR	Read	0x0
0x30	Receive Data Register	MCI_RDR	Read	0x0
0x34	Transmit Data Register	MCI_TDR	Write	–
0x38 - 0x3C	Reserved	–	–	–
0x40	Status Register	MCI_SR	Read	0xC0E5
0x44	Interrupt Enable Register	MCI_IER	Write	–
0x48	Interrupt Disable Register	MCI_IDR	Write	–
0x4C	Interrupt Mask Register	MCI_IMR	Read	0x0
0x50-0xFC	Reserved	–	–	–
0x100-0x124	Reserved for the PDC	–	–	–

Note: 1. The response register can be read by N accesses at the same MCI_RSPR or at consecutive addresses (0x20 to 0x2C). N depends on the size of the response.

33.9.1 MCI Control Register

Name: MCI_CR

Access Type: Write-only

31	30	29	28	27	26	25	24
–	–	–	–	–	–	–	–
23	22	21	20	19	18	17	16
–	–	–	–	–	–	–	–
15	14	13	12	11	10	9	8
–	–	–	–	–	–	–	–
7	6	5	4	3	2	1	0
SWRST	–	–	–	PWSDIS	PWSEN	MCIDIS	MCIEN

- **MCIEN: Multi-Media Interface Enable**

0 = No effect.

1 = Enables the Multi-Media Interface if MCDIS is 0.

- **MCIDIS: Multi-Media Interface Disable**

0 = No effect.

1 = Disables the Multi-Media Interface.

- **PWSEN: Power Save Mode Enable**

0 = No effect.

1 = Enables the Power Saving Mode if PWSDIS is 0.

Warning: Before enabling this mode, the user must set a value different from 0 in the PWSDIV field (Mode Register MCI_MR).

- **PWSDIS: Power Save Mode Disable**

0 = No effect.

1 = Disables the Power Saving Mode.

- **SWRST: Software Reset**

0 = No effect.

1 = Resets the MCI. A software triggered hardware reset of the MCI interface is performed.

33.9.2 MCI Mode Register

Name: MCI_MR

Access Type: Read/write

31	30	29	28	27	26	25	24
–	–	BLKLEN					
23	22	21	20	19	18	17	16
BLKLEN						0	0
15	14	13	12	11	10	9	8
PDCMODE	PDCPADV	–	–	–	PWSDIV		
7	6	5	4	3	2	1	0
CLKDIV							

- **CLKDIV: Clock Divider**

Multimedia Card Interface clock (MCCK or MCI_CK) is Master Clock (MCK) divided by $(2^{*(CLKDIV+1)})$.

- **PWSDIV: Power Saving Divider**

Multimedia Card Interface clock is divided by $2^{(PWSDIV)} + 1$ when entering Power Saving Mode.

Warning: This value must be different from 0 before enabling the Power Save Mode in the MCI_CR (MCI_PWSEN bit).

- **PDCPADV: PDC Padding Value**

0 = 0x00 value is used when padding data in write transfer (not only PDC transfer).

1 = 0xFF value is used when padding data in write transfer (not only PDC transfer).

- **PDCMODE: PDC-oriented Mode**

0 = Disables PDC transfer

1 = Enables PDC transfer. In this case, UNRE and OVRE flags in the MCI Mode Register (MCI_SR) are deactivated after the PDC transfer has been completed.

- **BLKLEN: Data Block Length**

This field determines the size of the data block.

Bits 16 and 17 must be set to 0.

33.9.3 MCI Data Timeout Register

Name: MCI_DTOR

Access Type: Read/write

31	30	29	28	27	26	25	24
–	–	–	–	–	–	–	–
23	22	21	20	19	18	17	16
–	–	–	–	–	–	–	–
15	14	13	12	11	10	9	8
–	–	–	–	–	–	–	–
7	6	5	4	3	2	1	0
–	DTOMUL			DTOCYC			

- **DTOCYC: Data Timeout Cycle Number**

- **DTOMUL: Data Timeout Multiplier**

These fields determine the maximum number of Master Clock cycles that the MCI waits between two data block transfers. It equals (DTCYC x Multiplier).

Multiplier is defined by DTOMUL as shown in the following table:

DTOMUL			Multiplier
0	0	0	1
0	0	1	16
0	1	0	128
0	1	1	256
1	0	0	1024
1	0	1	4096
1	1	0	65536
1	1	1	1048576

If the data time-out set by DTOCYC and DTOMUL has been exceeded, the Data Time-out Error flag (DTOE) in the MCI Status Register (MCI_SR) raises.

33.9.4 MCI SDCard Register

Name: MCI_SDCR

Access Type: Read/write

31	30	29	28	27	26	25	24
–	–	–	–	–	–	–	–
23	22	21	20	19	18	17	16
–	–	–	–	–	–	–	–
15	14	13	12	11	10	9	8
–	–	–	–	–	–	–	–
7	6	5	4	3	2	1	0
SDCBUS	–	–	–	–	–	SDCSEL	

- **SDCSEL: SDCard Slot**

SDCSEL		SDCard Slot
0	0	Slot A is selected.
0	1	Slot B is selected
1	0	Reserved
1	1	Reserved

- **SDCBUS: SDCard Bus Width**

0 = 1-bit data bus

1 = 4-bit data bus

33.9.5 MCI Argument Register

Name: MCI_ARGR

Access Type: Read/write

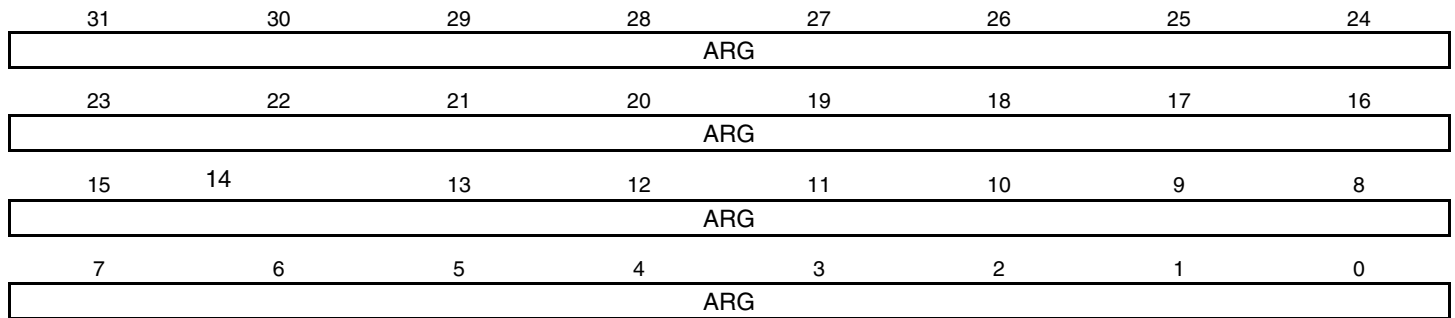

- **ARG: Command Argument**

33.9.6 MCI Command Register

Name: MCI_CMDR

Access Type: Write-only

31	30	29	28	27	26	25	24
–	–	–	–	–	–	–	–
23	22	21	20	19	18	17	16
–	–	–	TRTYP		TRDIR	TRCMD	
15	14	13	12	11	10	9	8
–	–	–	MAXLAT	OPDCMD	SPCMD		
7	6	5	4	3	2	1	0
RSPTYP		CMDNB					

This register is write-protected while CMDRDY is 0 in MCI_SR. If an Interrupt command is sent, this register is only write-able by an interrupt response (field SPCMD). This means that the current command execution cannot be interrupted or modified.

- **CMDNB: Command Number**
- **RSPTYP: Response Type**

RSP		Response Type
0	0	No response.
0	1	48-bit response.
1	0	136-bit response.
1	1	Reserved.

- **SPCMD: Special Command**

SPCMD			Command
0	0	0	Not a special CMD.
0	0	1	Initialization CMD: 74 clock cycles for initialization sequence.
0	1	0	Synchronized CMD: Wait for the end of the current data block transfer before sending the pending command.
0	1	1	Reserved.
1	0	0	Interrupt command: Corresponds to the Interrupt Mode (CMD40).
1	0	1	Interrupt response: Corresponds to the Interrupt Mode (CMD40).

- **OPDCMD: Open Drain Command**

0 = Push pull command

1 = Open drain command

- **MAXLAT: Max Latency for Command to Response**

0 = 5-cycle max latency

1 = 64-cycle max latency

- **TRCMD: Transfer Command**

TRCMD		Transfer Type
0	0	No data transfer
0	1	Start data transfer
1	0	Stop data transfer
1	1	Reserved

- **TRDIR: Transfer Direction**

0 = Write

1 = Read

- **TRTYP: Transfer Type**

TRTYP			Transfer Type
0	0	0	MMC/SDCard Single Block
0	0	1	MMC/SDCard Multiple Block
0	1	0	MMC Stream
0	1	1	Reserved

33.9.7 MCI Response Register

Name: MCI_RSPR

Access Type: Read-only

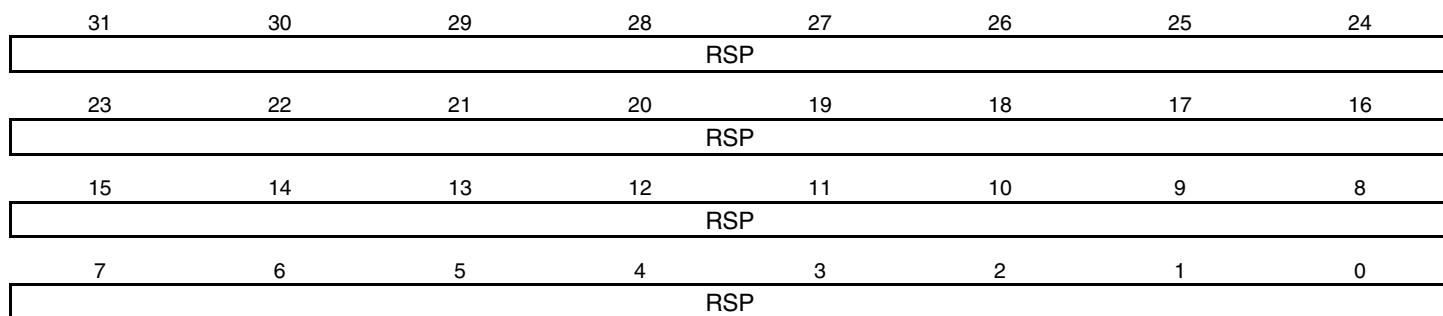

- **RSP: Response**

Note: 1. The response register can be read by N accesses at the same MCI_RSPR or at consecutive addresses (0x20 to 0x2C).
N depends on the size of the response.

33.9.8 MCI Receive Data Register

Name: MCI_RDR

Access Type: Read-only

31	30	29	28	27	26	25	24
DATA							
23	22	21	20	19	18	17	16
DATA							
15	14	13	12	11	10	9	8
DATA							
7	6	5	4	3	2	1	0
DATA							

- **DATA: Data to Read**

33.9.9 MCI Transmit Data Register

Name: MCI_TDR

Access Type: Write-only

31	30	29	28	27	26	25	24
DATA							
23	22	21	20	19	18	17	16
DATA							
15	14	13	12	11	10	9	8
DATA							
7	6	5	4	3	2	1	0
DATA							

- **DATA: Data to Write**

33.9.10 MCI Status Register

Name: MCI_SR

Access Type: Read-only

31	30	29	28	27	26	25	24
UNRE	OVRE	–	–	–	–	–	–
23	22	21	20	19	18	17	16
–	DTOE	DCRCE	RTOE	RENDE	RRCRCE	RDIR	RINDE
15	14	13	12	11	10	9	8
TXBUFE	RXBUFF	–	–	–	–	SDIOIRQB	SDIOIRQA
7	6	5	4	3	2	1	0
ENDTX	ENDRX	NOTBUSY	DTIP	BLKE	TXRDY	RXRDY	CMDRDY

- **CMDRDY: Command Ready**

0 = A command is in progress.

1 = The last command has been sent. Cleared when writing in the MCI_CMDR.

- **RXRDY: Receiver Ready**

0 = Data has not yet been received since the last read of MCI_RDR.

1 = Data has been received since the last read of MCI_RDR.

- **TXRDY: Transmit Ready**

0= The last data written in MCI_TDR has not yet been transferred in the Shift Register.

1= The last data written in MCI_TDR has been transferred in the Shift Register.

- **BLKE: Data Block Ended**

This flag must be used only for Write Operations.

0 = A data block transfer is not yet finished. Cleared when reading the MCI_SR.

1 = A data block transfer has ended, including the CRC16 Status transmission.

In PDC mode (PDCMODE=1), the flag is set when the CRC Status of the last block has been transmitted (TXBUFE already set).

Otherwise (PDCMODE=0), the flag is set for each transmitted CRC Status.

Refer to the MMC or SD Specification for more details concerning the CRC Status.

- **DTIP: Data Transfer in Progress**

0 = No data transfer in progress.

1 = The current data transfer is still in progress, including CRC16 calculation. Cleared at the end of the CRC16 calculation.

- **NOTBUSY: MCI Not Busy**

This flag must be used only for Write Operations.

A block write operation uses a simple busy signalling of the write operation duration on the data (DAT0) line: during a data transfer block, if the card does not have a free data receive buffer, the card indicates this condition by pulling down the data line (DAT0) to LOW. The card stops pulling down the data line as soon as at least one receive buffer for the defined data transfer block length becomes free.

The NOTBUSY flag allows to deal with these different states.

0 = The MCI is not ready for new data transfer. Cleared at the end of the card response.

1 = The MCI is ready for new data transfer. Set when the busy state on the data line has ended. This corresponds to a free internal data receive buffer of the card.

Refer to the MMC or SD Specification for more details concerning the busy behavior.

- **ENDRX: End of RX Buffer**

0 = The Receive Counter Register has not reached 0 since the last write in MCI_RCR or MCI_RNCR.

1 = The Receive Counter Register has reached 0 since the last write in MCI_RCR or MCI_RNCR.

- **ENDTX: End of TX Buffer**

0 = The Transmit Counter Register has not reached 0 since the last write in MCI_TCR or MCI_TNCR.

1 = The Transmit Counter Register has reached 0 since the last write in MCI_TCR or MCI_TNCR.

Note: BLKE and NOTBUSY flags can be used to check that the data has been successfully transmitted on the data lines and not only transferred from the PDC to the MCI Controller.

- **RXBUFF: RX Buffer Full**

0 = MCI_RCR or MCI_RNCR has a value other than 0.

1 = Both MCI_RCR and MCI_RNCR have a value of 0.

- **TXBUFE: TX Buffer Empty**

0 = MCI_TCR or MCI_TNCR has a value other than 0.

1 = Both MCI_TCR and MCI_TNCR have a value of 0.

Note: BLKE and NOTBUSY flags can be used to check that the data has been successfully transmitted on the data lines and not only transferred from the PDC to the MCI Controller.

- **RINDE: Response Index Error**

0 = No error.

1 = A mismatch is detected between the command index sent and the response index received. Cleared when writing in the MCI_CMDR.

- **RDIRE: Response Direction Error**

0 = No error.

1 = The direction bit from card to host in the response has not been detected.

- **RRCRE: Response CRC Error**

0 = No error.

1 = A CRC7 error has been detected in the response. Cleared when writing in the MCI_CMDR.

- **RENDE: Response End Bit Error**

0 = No error.

1 = The end bit of the response has not been detected. Cleared when writing in the MCI_CMDR.

- **RTOE: Response Time-out Error**



0 = No error.

1 = The response time-out set by MAXLAT in the MCI_CMDR has been exceeded. Cleared when writing in the MCI_CMDR.

- **DCRCE: Data CRC Error**

0 = No error.

1 = A CRC16 error has been detected in the last data block. Reset by reading in the MCI_SR register.

- **DTOE: Data Time-out Error**

0 = No error.

1 = The data time-out set by DTOCYC and DTOMUL in MCI_DTOR has been exceeded. Reset by reading in the MCI_SR register.

- **OVRE: Overrun**

0 = No error.

1 = At least one 8-bit received data has been lost (not read). Cleared when sending a new data transfer command.

- **UNRE: Underrun**

0 = No error.

1 = At least one 8-bit data has been sent without valid information (not written). Cleared when sending a new data transfer command.

- **RXBUFF: RX Buffer Full**

0 = MCI_RCR or MCI_RNCR has a value other than 0.

1 = Both MCI_RCR and MCI_RNCR have a value of 0.

- **TXBUFE: TX Buffer Empty**

0 = MCI_TCR or MCI_TNCR has a value other than 0.

1 = Both MCI_TCR and MCI_TNCR have a value of 0.

33.9.11 MCI Interrupt Enable Register

Name: MCI_IER

Access Type: Write-only

31	30	29	28	27	26	25	24
UNRE	OVRE	–	–	–	–	–	–
23	22	21	20	19	18	17	16
–	DTOE	DCRCE	RTOE	RENDE	RCRCE	RDIRE	RINDE
15	14	13	12	11	10	9	8
TXBUFE	RXBUFF	–	–	–	–	SDIOIRQB	SDIOIRQA
7	6	5	4	3	2	1	0
ENDTX	ENDRX	NOTBUSY	DTIP	BLKE	TXRDY	RXRDY	CMDRDY

- **CMDRDY: Command Ready Interrupt Enable**
- **RXRDY: Receiver Ready Interrupt Enable**
- **TXRDY: Transmit Ready Interrupt Enable**
- **BLKE: Data Block Ended Interrupt Enable**
- **DTIP: Data Transfer in Progress Interrupt Enable**
- **NOTBUSY: Data Not Busy Interrupt Enable**
- **ENDRX: End of Receive Buffer Interrupt Enable**
- **ENDTX: End of Transmit Buffer Interrupt Enable**
- **RXBUFF: Receive Buffer Full Interrupt Enable**
- **TXBUFE: Transmit Buffer Empty Interrupt Enable**
- **RINDE: Response Index Error Interrupt Enable**
- **RDIRE: Response Direction Error Interrupt Enable**
- **RCRCE: Response CRC Error Interrupt Enable**
- **RENDE: Response End Bit Error Interrupt Enable**
- **RTOE: Response Time-out Error Interrupt Enable**
- **DCRCE: Data CRC Error Interrupt Enable**
- **DTOE: Data Time-out Error Interrupt Enable**
- **OVRE: Overrun Interrupt Enable**
- **UNRE: UnderRun Interrupt Enable**

0 = No effect.

1 = Enables the corresponding interrupt.

33.9.12 MCI Interrupt Disable Register

Name: MCI_IDR

Access Type: Write-only

31	30	29	28	27	26	25	24
UNRE	OVRE	–	–	–	–	–	–
23	22	21	20	19	18	17	16
–	DTOE	DCRCE	RTOE	RENDE	RCRCE	RDIRE	RINDE
15	14	13	12	11	10	9	8
TXBUFE	RXBUFFER	–	–	–	–	SDIOIRQB	SDIOIRQA
7	6	5	4	3	2	1	0
ENDTX	ENDRX	NOTBUSY	DTIP	BLKE	TXRDY	RXRDY	CMDRDY

- **CMDRDY: Command Ready Interrupt Disable**
- **RXRDY: Receiver Ready Interrupt Disable**
- **TXRDY: Transmit Ready Interrupt Disable**
- **BLKE: Data Block Ended Interrupt Disable**
- **DTIP: Data Transfer in Progress Interrupt Disable**
- **NOTBUSY: Data Not Busy Interrupt Disable**
- **ENDRX: End of Receive Buffer Interrupt Disable**
- **ENDTX: End of Transmit Buffer Interrupt Disable**
- **RXBUFFER: Receive Buffer Full Interrupt Disable**
- **TXBUFE: Transmit Buffer Empty Interrupt Disable**
- **RINDE: Response Index Error Interrupt Disable**
- **RDIRE: Response Direction Error Interrupt Disable**
- **RCRCE: Response CRC Error Interrupt Disable**
- **RENDE: Response End Bit Error Interrupt Disable**
- **RTOE: Response Time-out Error Interrupt Disable**
- **DCRCE: Data CRC Error Interrupt Disable**
- **DTOE: Data Time-out Error Interrupt Disable**
- **OVRE: Overrun Interrupt Disable**
- **UNRE: UnderRun Interrupt Disable**

0 = No effect.

1 = Disables the corresponding interrupt.

33.9.13 MCI Interrupt Mask Register

Name: MCI_IMR

Access Type: Read-only

31	30	29	28	27	26	25	24
UNRE	OVRE	–	–	–	–	–	–
23	22	21	20	19	18	17	16
–	DTOE	DCRCE	RTOE	RENDE	RCRCE	RDIRE	RINDE
15	14	13	12	11	10	9	8
TXBUFE	RXBUFF	–	–	–	–	SDIOIRQB	SDIOIRQA
7	6	5	4	3	2	1	0
ENDTX	ENDRX	NOTBUSY	DTIP	BLKE	TXRDY	RXRDY	CMDRDY

- **CMDRDY: Command Ready Interrupt Mask**
- **RXRDY: Receiver Ready Interrupt Mask**
- **TXRDY: Transmit Ready Interrupt Mask**
- **BLKE: Data Block Ended Interrupt Mask**
- **DTIP: Data Transfer in Progress Interrupt Mask**
- **NOTBUSY: Data Not Busy Interrupt Mask**
- **ENDRX: End of Receive Buffer Interrupt Mask**
- **ENDTX: End of Transmit Buffer Interrupt Mask**
- **RXBUFF: Receive Buffer Full Interrupt Mask**
- **TXBUFE: Transmit Buffer Empty Interrupt Mask**
- **RINDE: Response Index Error Interrupt Mask**
- **RDIRE: Response Direction Error Interrupt Mask**
- **RCRCE: Response CRC Error Interrupt Mask**
- **RENDE: Response End Bit Error Interrupt Mask**
- **RTOE: Response Time-out Error Interrupt Mask**
- **DCRCE: Data CRC Error Interrupt Mask**
- **DTOE: Data Time-out Error Interrupt Mask**
- **OVRE: Overrun Interrupt Mask**
- **UNRE: UnderRun Interrupt Mask**

0 = The corresponding interrupt is not enabled.

1 = The corresponding interrupt is enabled.



34. USB Device Port (UDP)

34.1 Overview

The USB Device Port (UDP) is compliant with the Universal Serial Bus (USB) V2.0 full-speed device specification.

Each endpoint is associated with one or two banks of a dual-port RAM used to store the current data payload. If two banks are used, one DPR bank is read or written by the processor, while the other is read or written by the USB device peripheral. This feature is mandatory for isochronous endpoints. Thus the device maintains the maximum bandwidth (1M bytes/s) by working with endpoints with two banks of DPR.

Suspend and resume are automatically detected by the USB device, which notifies the processor by raising an interrupt. Depending on the product, an external signal can be used to send a wake-up to the USB host controller.

The main features of the UDP are:

- USB V2.0 Full-speed Compliant, 12 Mbits per second
- Embedded USB V2.0 Full-speed Transceiver
- Embedded Dual-port RAM for Endpoints
- Suspend/Resume Logic
- Ping-pong Mode (2 Memory Banks) for Isochronous and Bulk Endpoints

34.2 Block Diagram

Figure 34-1. USB Device Port Block Diagram

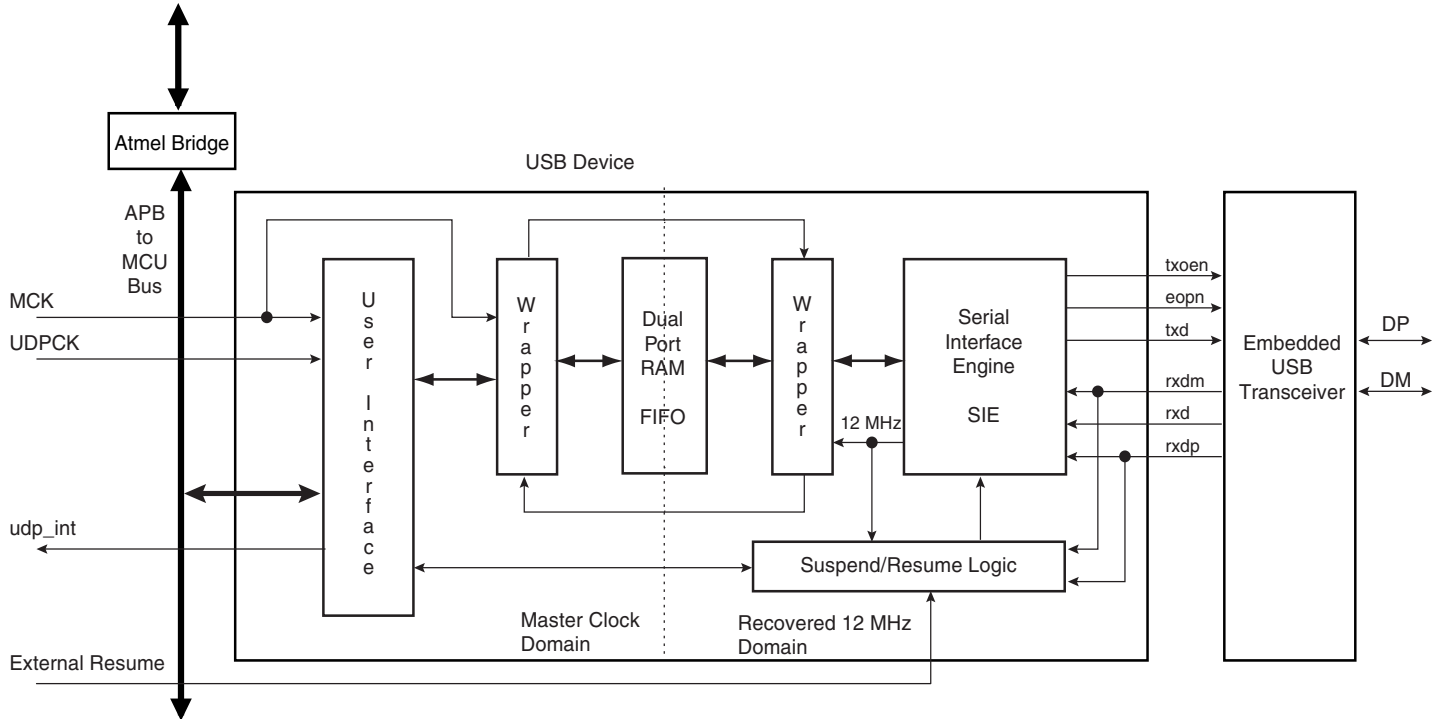

Access to the UDP is via the APB bus interface. Read and write to the data FIFO are done by reading and writing 8-bit values to APB registers.

The UDP peripheral requires two clocks: one peripheral clock used by the MCK domain and a 48 MHz clock used by the 12 MHz domain.

A USB 2.0 full-speed pad is embedded and controlled by the SIE.

The signal `external_resume` is optional. It allows the UDP peripheral to wake-up once in system mode. The host will then be notified that the device asks for a resume. This optional feature must be also negotiated with the host during the enumeration.

34.3 Product Dependencies

The USB physical transceiver is integrated into the product. The bi-directional differential signals DP and DM are available from the product boundary.

Two I/O lines may be used by the application:

- One to check that VBUS is still available from the host. Self-powered devices may use this entry to be notified that the host has been powered off. In this case, the board pull-up on DP must be disabled in order to prevent feeding current to the host.
- One to control the board pull-up on DP. Thus, when the device is ready to communicate with the host, it activates its DP pull-up through this control line.

34.3.1 I/O Lines

DP and DM are not controlled by any PIO controllers. The embedded USB physical transceiver is controlled by the USB device peripheral.

To reserve an I/O line to check VBUS, the programmer must first program the PIO controller to assign this I/O in input PIO mode.

To reserve an I/O line to control the board pull-up, the programmer must first program the PIO controller to assign this I/O in output PIO mode.

34.3.2 Power Management

The USB device peripheral requires a 48 MHz clock. This clock must be generated by a PLL with an accuracy of $\pm 0.25\%$.

Thus, the USB device receives two clocks from the Power Management Controller (PMC): the master clock, MCK, used to drive the peripheral user interface and the UDPCK used to interface with the bus USB signals (recovered 12 MHz domain).

34.3.3 Interrupt

The USB device interface has an interrupt line connected to the Advanced Interrupt Controller (AIC).

Handling the USB device interrupt requires programming the AIC before configuring the UDP.

34.4 Typical Connection

Figure 34-2. Board Schematic to Interface USB Device Peripheral

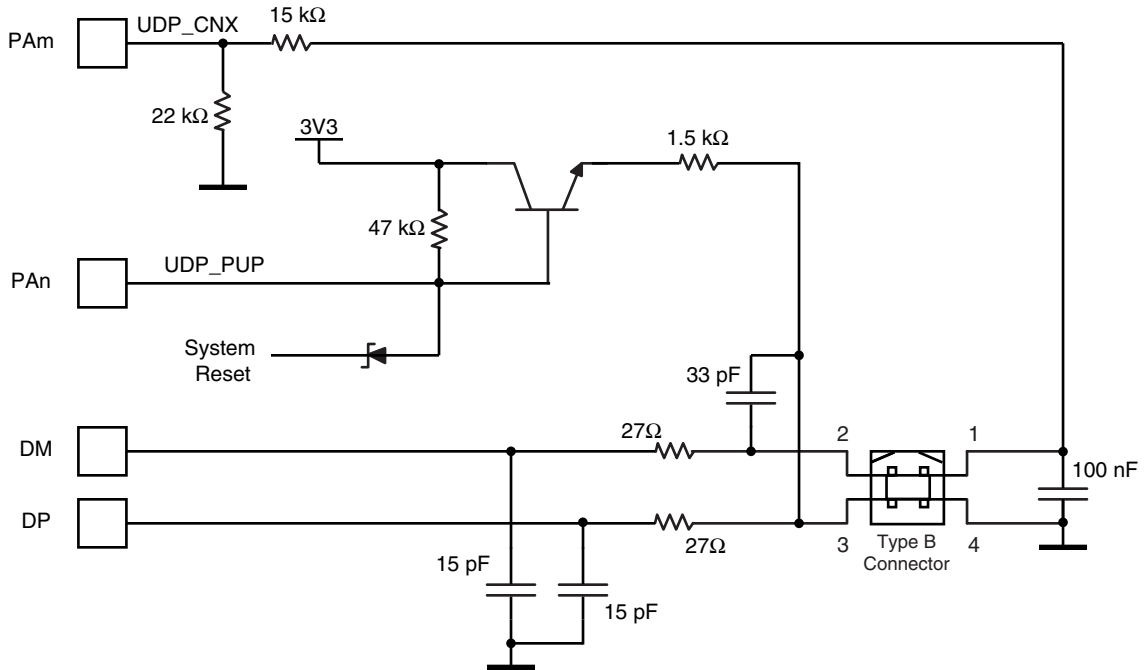

UDP_CNX is an input signal used to check if the host is connected

UDP_PUP is an output signal used to enable pull-up on DP.

Figure 34-2 shows automatic activation of pull-up after reset.

34.5 Functional Description

34.5.1 USB V2.0 Full-speed Introduction

The USB V2.0 full-speed provides communication services between host and attached USB devices. Each device is offered with a collection of communication flows (pipes) associated with each endpoint. Software on the host communicates with an USB device through a set of communication flows.

Figure 34-3. Example of USB V2.0 Full-speed Communication Control

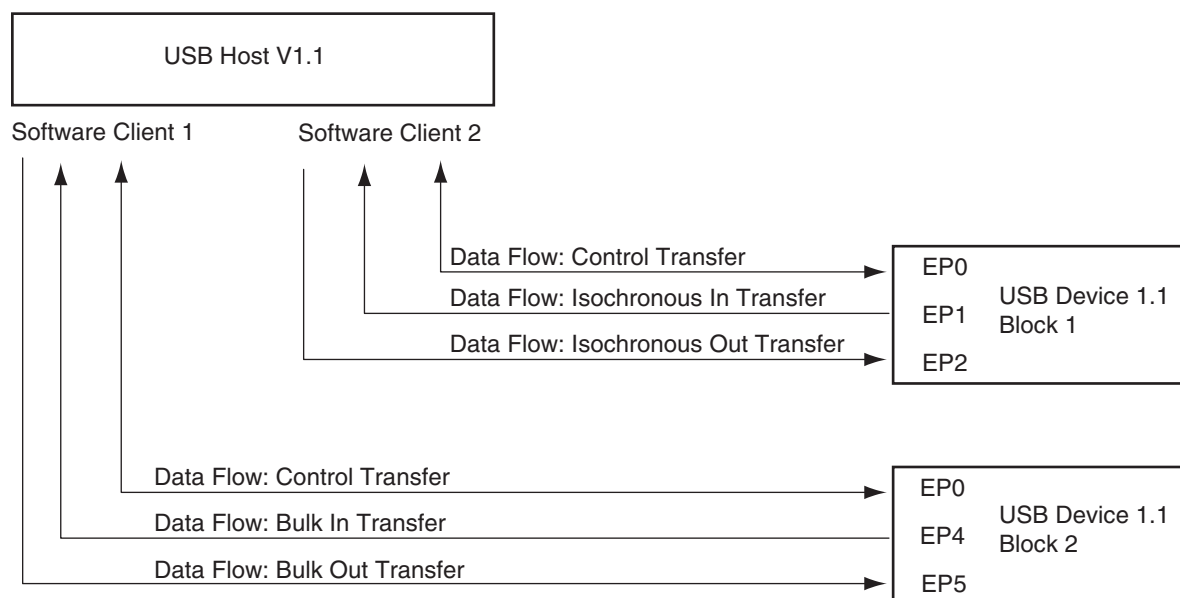

34.5.1.1 USB V2.0 Full-speed Transfer Types

A communication flow is carried over one of four transfer types defined by the USB device.

Table 34-1. USB Communication Flow

Transfer	Direction	Bandwidth	Supported Endpoint Size	Error Detection	Retrying
Control	Bi-directional	Not guaranteed	8	Yes	Automatic
Isochronous	Uni-directional	Guaranteed	1 - 1023	Yes	No
Interrupt	Uni-directional	Not guaranteed	≤256	Yes	Yes
Bulk	Uni-directional	Not guaranteed	8, 16, 32, 64	Yes	Yes

34.5.1.2 USB Bus Transactions

Each transfer results in one or more transactions over the USB bus. There are five kinds of transactions flowing across the bus in packets:

1. Setup Transaction
2. Data IN Transaction
3. Data OUT Transaction
4. Status IN Transaction
5. Status OUT Transaction

34.5.1.3 USB Transfer Event Definitions

As shown in [Table 34-2](#), transfers are sequential events carried out on the USB bus.

Table 34-2. USB Transfer Events

Control Transfers ^{(1) (3)}	<ul style="list-style-type: none"> • Setup transaction > Data IN transactions > Status OUT transaction • Setup transaction > Data OUT transactions > Status IN transaction • Setup transaction > Status IN transaction
Interrupt IN Transfer (device toward host)	<ul style="list-style-type: none"> • Data IN transaction > Data IN transaction
Interrupt OUT Transfer (host toward device)	<ul style="list-style-type: none"> • Data OUT transaction > Data OUT transaction
Isochronous IN Transfer ⁽²⁾ (device toward host)	<ul style="list-style-type: none"> • Data IN transaction > Data IN transaction
Isochronous OUT Transfer ⁽²⁾ (host toward device)	<ul style="list-style-type: none"> • Data OUT transaction > Data OUT transaction
Bulk IN Transfer (device toward host)	<ul style="list-style-type: none"> • Data IN transaction > Data IN transaction
Bulk OUT Transfer (host toward device)	<ul style="list-style-type: none"> • Data OUT transaction > Data OUT transaction

- Notes:
1. Control transfer must use endpoints with no ping-pong attributes.
 2. Isochronous transfers must use endpoints with ping-pong attributes.
 3. Control transfers can be aborted using a stall handshake.

34.5.2 Handling Transactions with USB V2.0 Device Peripheral

34.5.2.1 Setup Transaction

Setup is a special type of host-to-device transaction used during control transfers. Control transfers must be performed using endpoints with no ping-pong attributes. A setup transaction needs to be handled as soon as possible by the firmware. It is used to transmit requests from the host to the device. These requests are then handled by the USB device and may require more arguments. The arguments are sent to the device by a Data OUT transaction which follows the setup transaction. These requests may also return data. The data is carried out to the host by the next Data IN transaction which follows the setup transaction. A status transaction ends the control transfer.

When a setup transfer is received by the USB endpoint:

- The USB device automatically acknowledges the setup packet
- RXSETUP is set in the UDP_CSRx register
- An endpoint interrupt is generated while the RXSETUP is not cleared. This interrupt is carried out to the microcontroller if interrupts are enabled for this endpoint.

Thus, firmware must detect the RXSETUP polling the UDP_CSRx or catching an interrupt, read the setup packet in the FIFO, then clear the RXSETUP. RXSETUP cannot be cleared before the setup packet has been read in the FIFO. Otherwise, the USB device would accept the next Data OUT transfer and overwrite the setup packet in the FIFO.

Figure 34-4. Setup Transaction Followed by a Data OUT Transaction

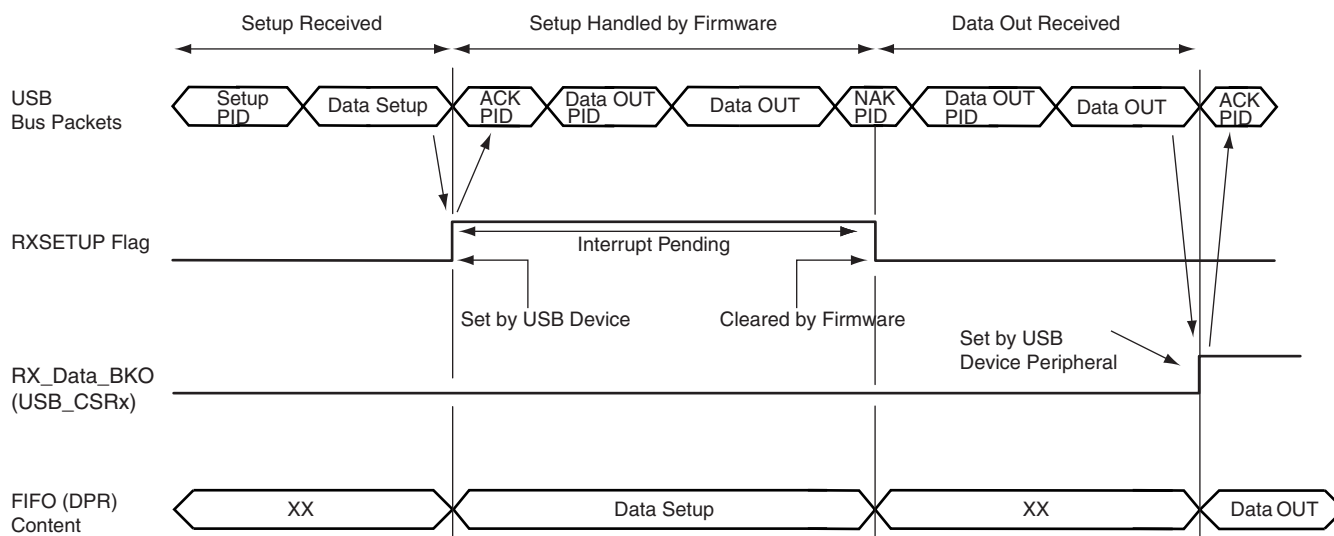

34.5.2.2 Data IN Transaction

Data IN transactions are used in control, isochronous, bulk and interrupt transfers and conduct the transfer of data from the device to the host. Data IN transactions in isochronous transfer must be done using endpoints with ping-pong attributes.

Using Endpoints Without Ping-pong Attributes

To perform a Data IN transaction, using a non ping-pong endpoint:

1. The microcontroller checks if it is possible to write in the FIFO by polling TXPKTRDY in the endpoint's UDP_CSRx register (TXPKTRDY must be cleared).
2. The microcontroller writes data to be sent in the endpoint's FIFO, writing zero or more byte values in the endpoint's UDP_FDRx register,
3. The microcontroller notifies the USB peripheral it has finished by setting the TXPKTRDY in the endpoint's UDP_CSRx register,
4. The microcontroller is notified that the endpoint's FIFO has been released by the USB device when TXCOMP in the endpoint's UDP_CSRx register has been set. Then an interrupt for the corresponding endpoint is pending while TXCOMP is set.

TXCOMP is set by the USB device when it has received an ACK PID signal for the Data IN packet. An interrupt is pending while TXCOMP is set.

Note: Please refer to Chapter 8 of the *Universal Serial Bus Specification, Rev 1.1*, for more information on the Data IN protocol layer.

Figure 34-5. Data IN Transfer for Non Ping-pong Endpoint

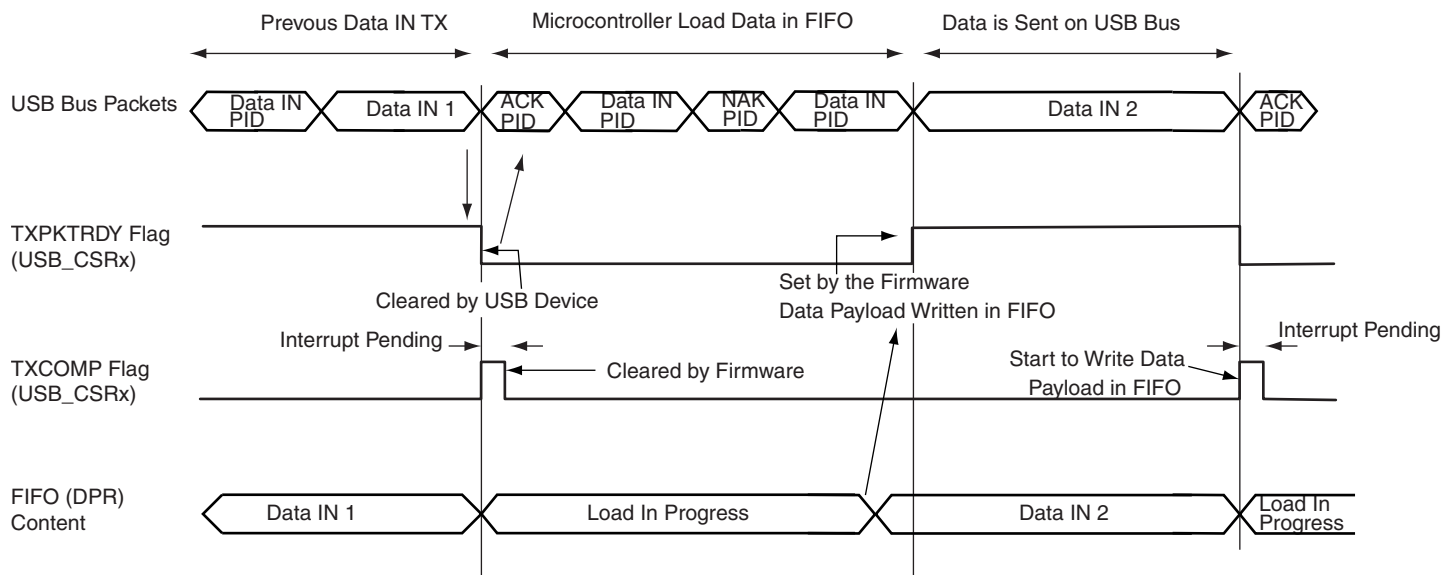

Using Endpoints With Ping-pong Attribute

The use of an endpoint with ping-pong attributes is necessary during isochronous transfer. To be able to guarantee a constant bandwidth, the microcontroller must prepare the next data payload to be sent while the current one is being sent by the USB device. Thus two banks of memory are used. While one is available for the microcontroller, the other one is locked by the USB device.

Figure 34-6. Bank Swapping Data IN Transfer for Ping-pong Endpoints

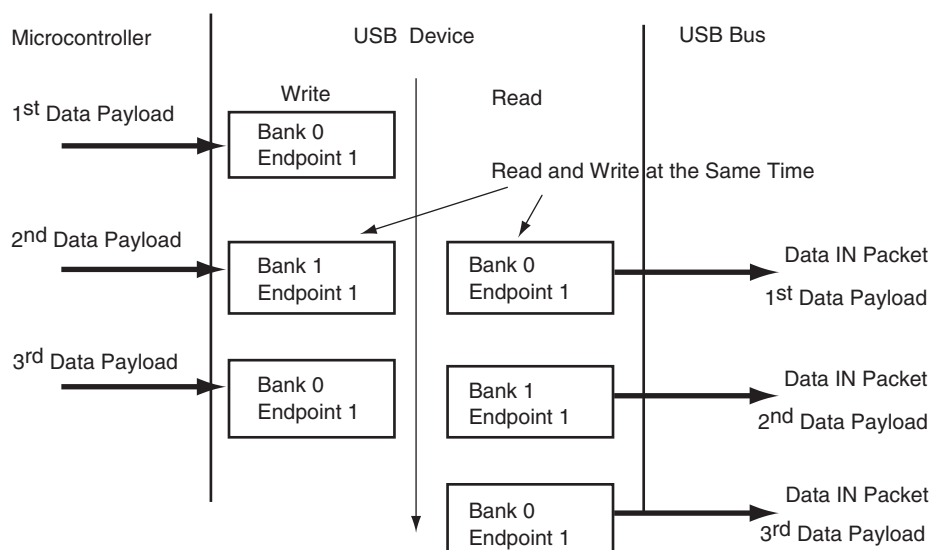

When using a ping-pong endpoint, the following procedures are required to perform Data IN transactions:

1. The microcontroller checks if it is possible to write in the FIFO by polling TXPKTRDY to be cleared in the endpoint's UDP_CSRx register.
2. The microcontroller writes the first data payload to be sent in the FIFO (Bank 0), writing zero or more byte values in the endpoint's UDP_FDRx register.
3. The microcontroller notifies the USB peripheral it has finished writing in Bank 0 of the FIFO by setting the TXPKTRDY in the endpoint's UDP_CSRx register.
4. Without waiting for TXPKTRDY to be cleared, the microcontroller writes the second data payload to be sent in the FIFO (Bank 1), writing zero or more byte values in the endpoint's UDP_FDRx register.
5. The microcontroller is notified that the first Bank has been released by the USB device when TXCOMP in the endpoint's UDP_CSRx register is set. An interrupt is pending while TXCOMP is being set.
6. Once the microcontroller has received TXCOMP for the first Bank, it notifies the USB device that it has prepared the second Bank to be sent rising TXPKTRDY in the endpoint's UDP_CSRx register.
7. At this step, Bank 0 is available and the microcontroller can prepare a third data payload to be sent.

Figure 34-7. Data IN Transfer for Ping-pong Endpoint

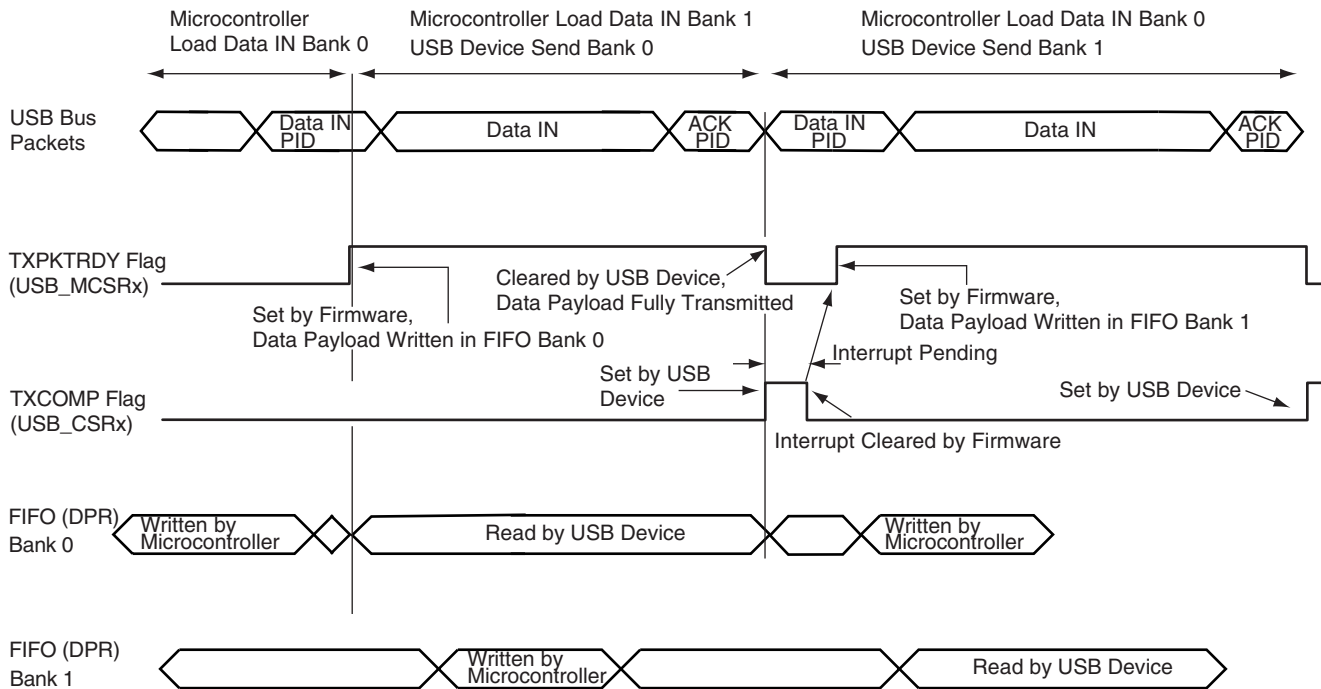

Warning: There is software critical path due to the fact that once the second bank is filled, the driver has to wait for TX_COMP to set TX_PKTRDY. If the delay between receiving TX_COMP is set and TX_PKTRDY is set is too long, some Data IN packets may be NACKed, reducing the bandwidth.

34.5.2.3 Data OUT Transaction

Data OUT transactions are used in control, isochronous, bulk and interrupt transfers and conduct the transfer of data from the host to the device. Data OUT transactions in isochronous transfers must be done using endpoints with ping-pong attributes.

Data OUT Transaction Without Ping-pong Attributes

To perform a Data OUT transaction, using a non ping-pong endpoint:

1. The host generates a Data OUT packet.
2. This packet is received by the USB device endpoint. While the FIFO associated to this endpoint is being used by the microcontroller, a NAK PID is returned to the host. Once the FIFO is available, data are written to the FIFO by the USB device and an ACK is automatically carried out to the host.
3. The microcontroller is notified that the USB device has received a data payload polling RX_DATA_BK0 in the endpoint's UDP_CSRx register. An interrupt is pending for this endpoint while RX_DATA_BK0 is set.
4. The number of bytes available in the FIFO is made available by reading RXBYTECNT in the endpoint's UDP_CSRx register.

5. The microcontroller carries out data received from the endpoint's memory to its memory. Data received is available by reading the endpoint's UDP_FDRx register.
6. The microcontroller notifies the USB device that it has finished the transfer by clearing RX_DATA_BK0 in the endpoint's UDP_CSRx register.
7. A new Data OUT packet can be accepted by the USB device.

Figure 34-8. Data OUT Transfer for Non Ping-pong Endpoints

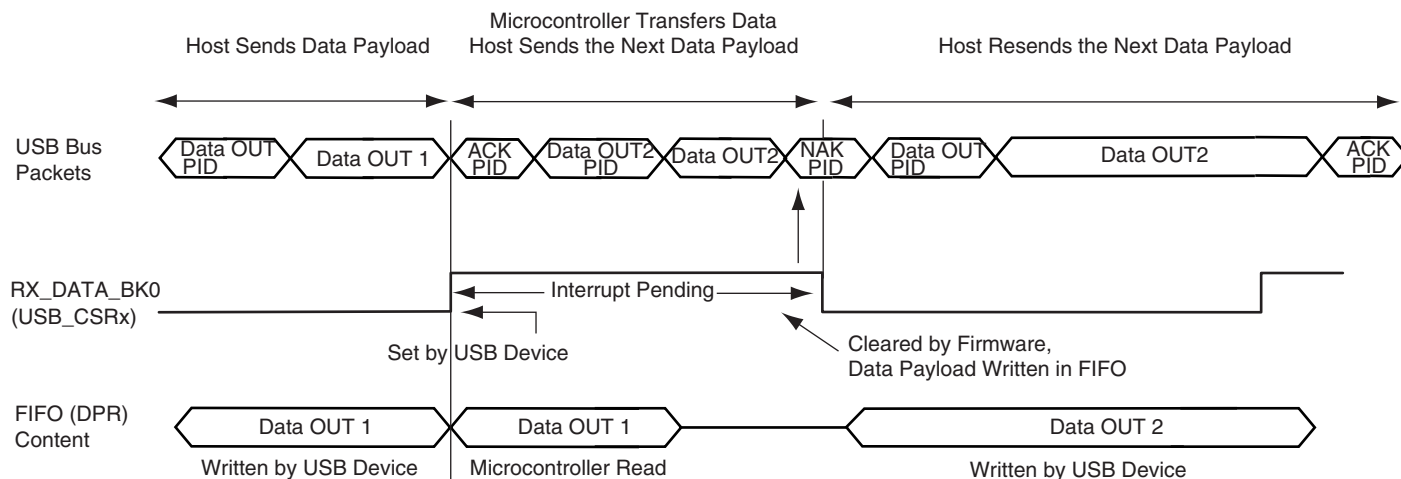

An interrupt is pending while the flag RX_DATA_BK0 is set. Memory transfer between the USB device, the FIFO and microcontroller memory can not be done after RX_DATA_BK0 has been cleared. Otherwise, the USB device would accept the next Data OUT transfer and overwrite the current Data OUT packet in the FIFO.

Using Endpoints With Ping-pong Attributes

During isochronous transfer, using an endpoint with ping-pong attributes is necessary. To be able to guarantee a constant bandwidth, the microcontroller must read the previous data payload sent by the host, while the current data payload is received by the USB device. Thus two banks of memory are used. While one is available for the microcontroller, the other one is locked by the USB device.

Figure 34-9. Bank Swapping in Data OUT Transfers for Ping-pong Endpoints

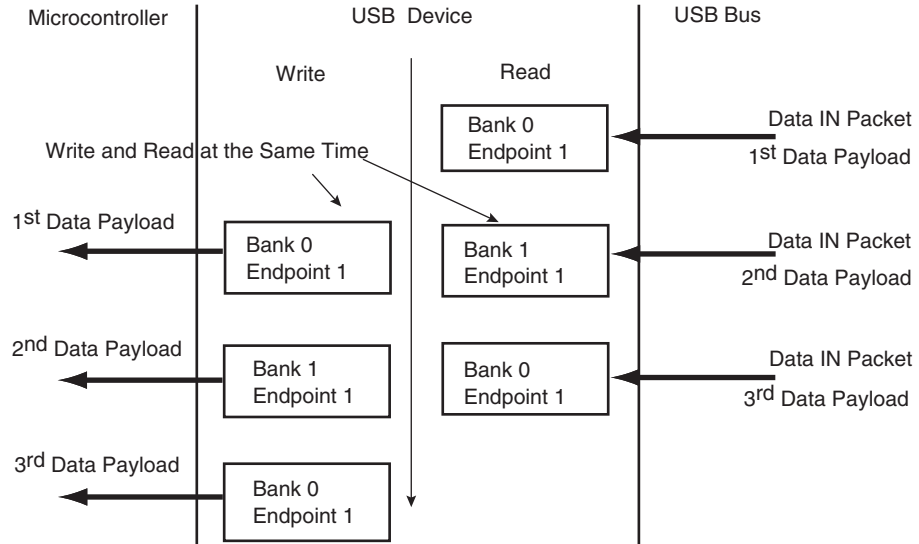

When using a ping-pong endpoint, the following procedures are required to perform Data OUT transactions:

1. The host generates a Data OUT packet.
2. This packet is received by the USB device endpoint. It is written in the endpoint's FIFO Bank 0.
3. The USB device sends an ACK PID packet to the host. The host can immediately send a second Data OUT packet. It is accepted by the device and copied to FIFO Bank 1.
4. The microcontroller is notified that the USB device has received a data payload, polling `RX_DATA_BK0` in the endpoint's `UDP_CSRx` register. An interrupt is pending for this endpoint while `RX_DATA_BK0` is set.
5. The number of bytes available in the FIFO is made available by reading `RXBYTECNT` in the endpoint's `UDP_CSRx` register.
6. The microcontroller transfers out data received from the endpoint's memory to the microcontroller's memory. Data received is made available by reading the endpoint's `UDP_FDRx` register.
7. The microcontroller notifies the USB peripheral device that it has finished the transfer by clearing `RX_DATA_BK0` in the endpoint's `UDP_CSRx` register.
8. A third Data OUT packet can be accepted by the USB peripheral device and copied in the FIFO Bank 0.
9. If a second Data OUT packet has been received, the microcontroller is notified by the flag `RX_DATA_BK1` set in the endpoint's `UDP_CSRx` register. An interrupt is pending for this endpoint while `RX_DATA_BK1` is set.
10. The microcontroller transfers out data received from the endpoint's memory to the microcontroller's memory. Data received is available by reading the endpoint's `UDP_FDRx` register.
11. The microcontroller notifies the USB device it has finished the transfer by clearing `RX_DATA_BK1` in the endpoint's `UDP_CSRx` register.
12. A fourth Data OUT packet can be accepted by the USB device and copied in the FIFO Bank 0.

Figure 34-10. Data OUT Transfer for Ping-pong Endpoint

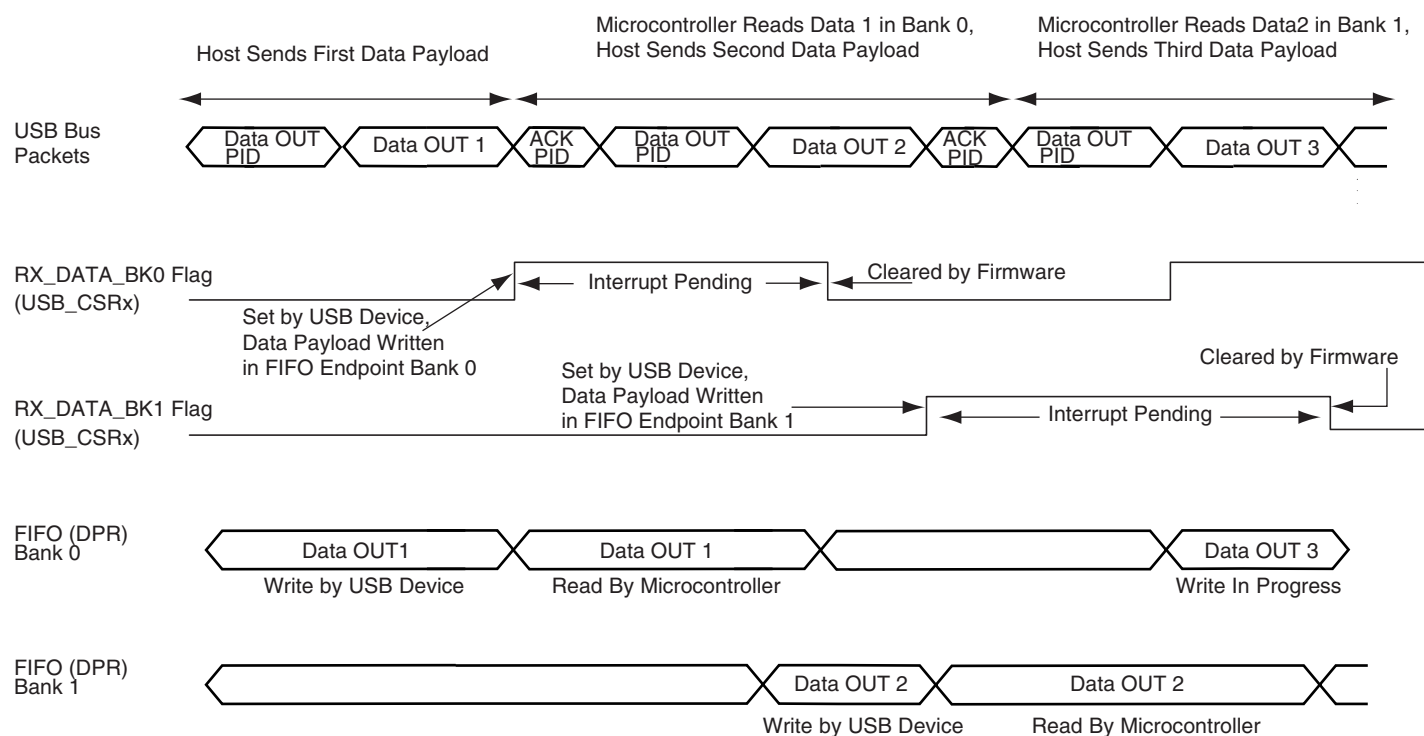

Note: An interrupt is pending while the RX_DATA_BK0 or RX_DATA_BK1 flag is set.

Warning: When RX_DATA_BK0 and RX_DATA_BK1 are both set, there is no way to determine which one to clear first. Thus the software must keep an internal counter to be sure to clear alternately RX_DATA_BK0 then RX_DATA_BK1. This situation may occur when the software application is busy elsewhere and the two banks are filled by the USB host. Once the application comes back to the USB driver, the two flags are set.

34.5.2.4 Status Transaction

A status transaction is a special type of host to device transaction used only in a control transfer. The control transfer must be performed using endpoints with no ping-pong attributes. According to the control sequence (read or write), the USB device sends or receives a status transaction.

Figure 34-11. Control Read and Write Sequences

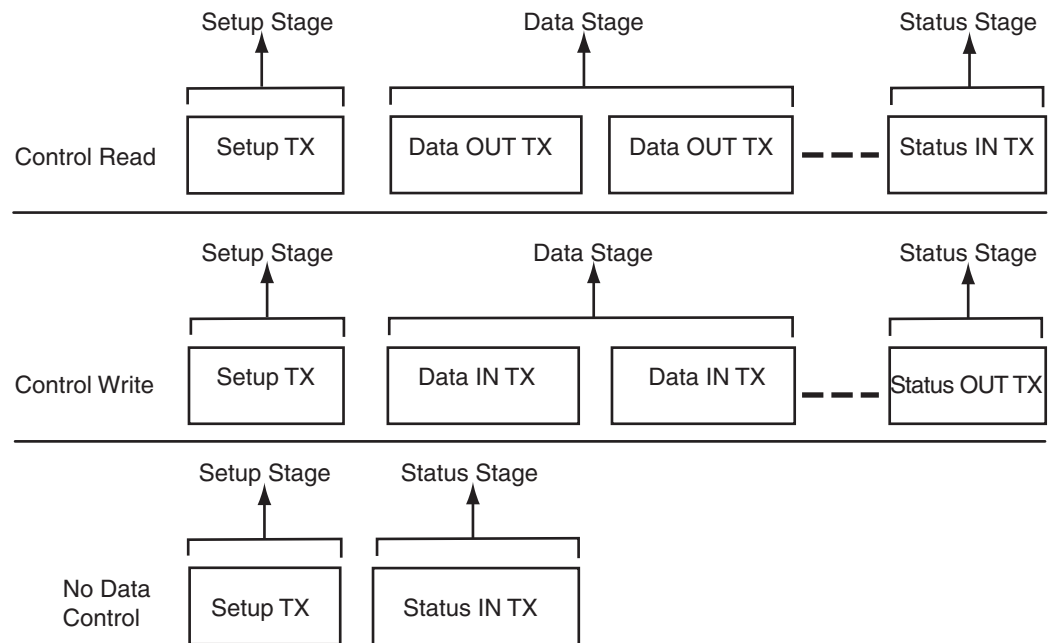

- Notes:
1. During the Status IN stage, the host waits for a zero length packet (Data IN transaction with no data) from the device using DATA1 PID. Please refer to Chapter 8 of the *Universal Serial Bus Specification, Rev. 1.1*, to get more information on the protocol layer.
 2. During the Status OUT stage, the host emits a zero length packet to the device (Data OUT transaction with no data).

34.5.2.5 Status IN Transfer

Once a control request has been processed, the device returns a status to the host. This is a zero length Data IN transaction.

1. The microcontroller waits for TXPKTRDY in the UDP_CSRx endpoint's register to be cleared. (At this step, TXPKTRDY must be cleared because the previous transaction was a setup transaction or a Data OUT transaction.)
2. Without writing anything to the UDP_FDRx endpoint's register, the microcontroller sets TXPKTRDY. The USB device generates a Data IN packet using DATA1 PID.
3. This packet is acknowledged by the host and TXPKTRDY is set in the UDP_CSRx endpoint's register.

Figure 34-12. Data Out Followed by Status IN Transfer.

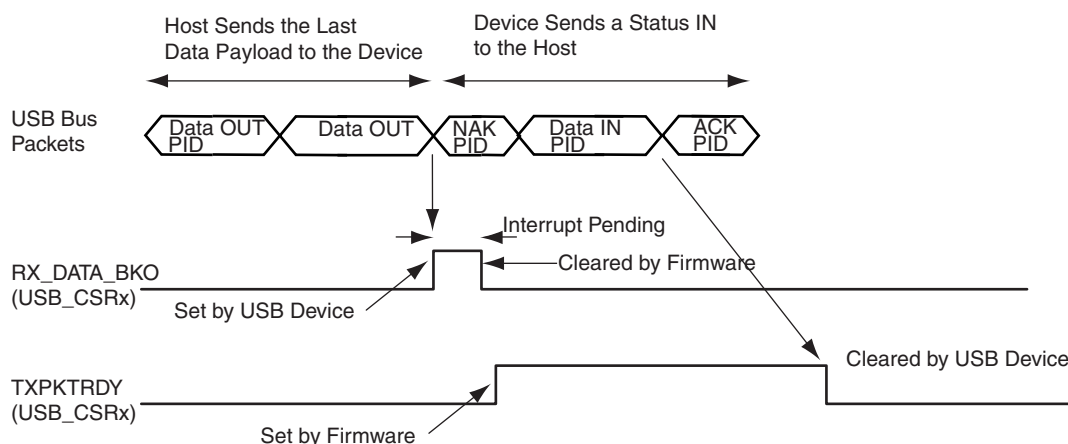

34.5.2.6 Status OUT Transfer

Once a control request has been processed and the requested data returned, the host acknowledges by sending a zero length packet. This is a zero length Data OUT transaction.

1. The USB device receives a zero length packet. It sets RX_DATA_BK0 flag in the UDP_CSRx register and acknowledges the zero length packet.
2. The microcontroller is notified that the USB device has received a zero length packet sent by the host polling RX_DATA_BK0 in the UDP_CSRx register. An interrupt is pending while RX_DATA_BK0 is set. The number of bytes received in the endpoint's UDP_BCR register is equal to zero.
3. The microcontroller must clear RX_DATA_BK0.

Figure 34-13. Data IN Followed by Status OUT Transfer

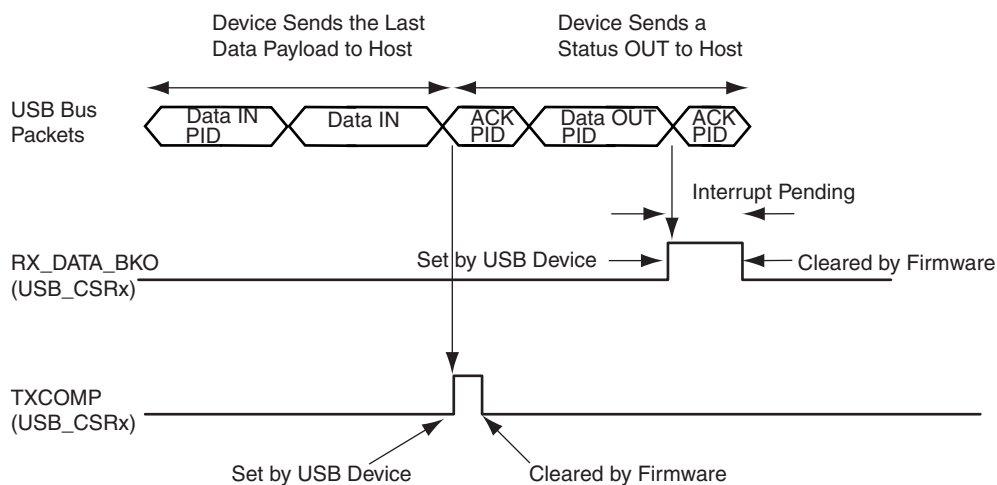

34.5.2.7 Stall Handshake

A stall handshake can be used in one of two distinct occasions. (For more information on the stall handshake, refer to Chapter 8 of the *Universal Serial Bus Specification, Rev 1.1*.)

- A functional stall is used when the halt feature associated with the endpoint is set. (Refer to Chapter 9 of the *Universal Serial Bus Specification, Rev 1.1*, for more information on the halt feature.)
- To abort the current request, a protocol stall is used, but uniquely with control transfer.

The following procedure generates a stall packet:

1. The microcontroller sets the FORCESTALL flag in the UDP_CSRx endpoint's register.
2. The host receives the stall packet.
3. The microcontroller is notified that the device has sent the stall by polling the STALLSENT to be set. An endpoint interrupt is pending while STALLSENT is set. The microcontroller must clear STALLSENT to clear the interrupt.

When a setup transaction is received after a stall handshake, STALLSENT must be cleared in order to prevent interrupts due to STALLSENT being set.

Figure 34-14. Stall Handshake (Data IN Transfer)

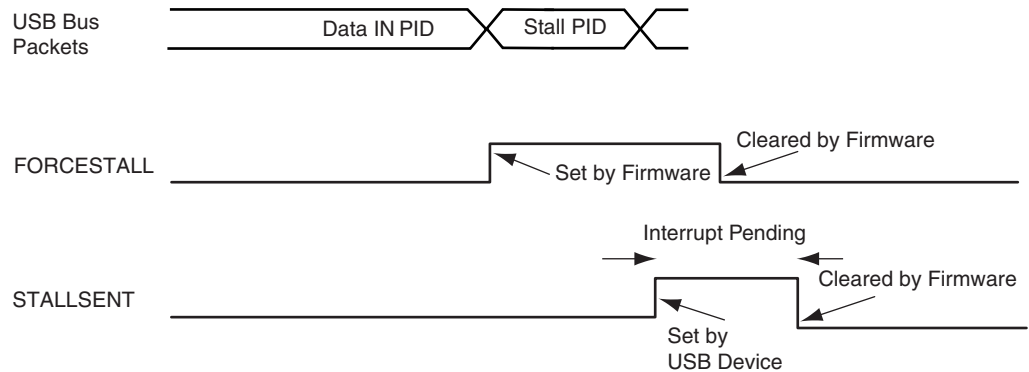
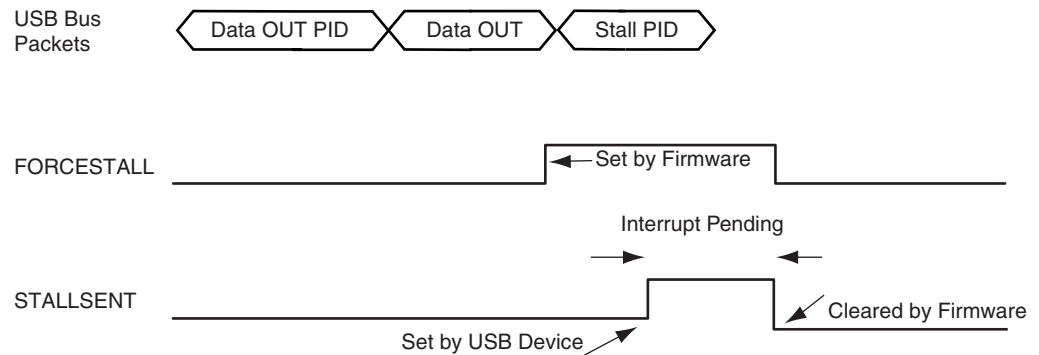

Figure 34-15. Stall Handshake (Data OUT Transfer)



34.5.3 Controlling Device States

A USB device has several possible states. Please refer to Chapter 9 of the *Universal Serial Bus Specification, Rev 1.1*.

Figure 34-16. USB Device State Diagram

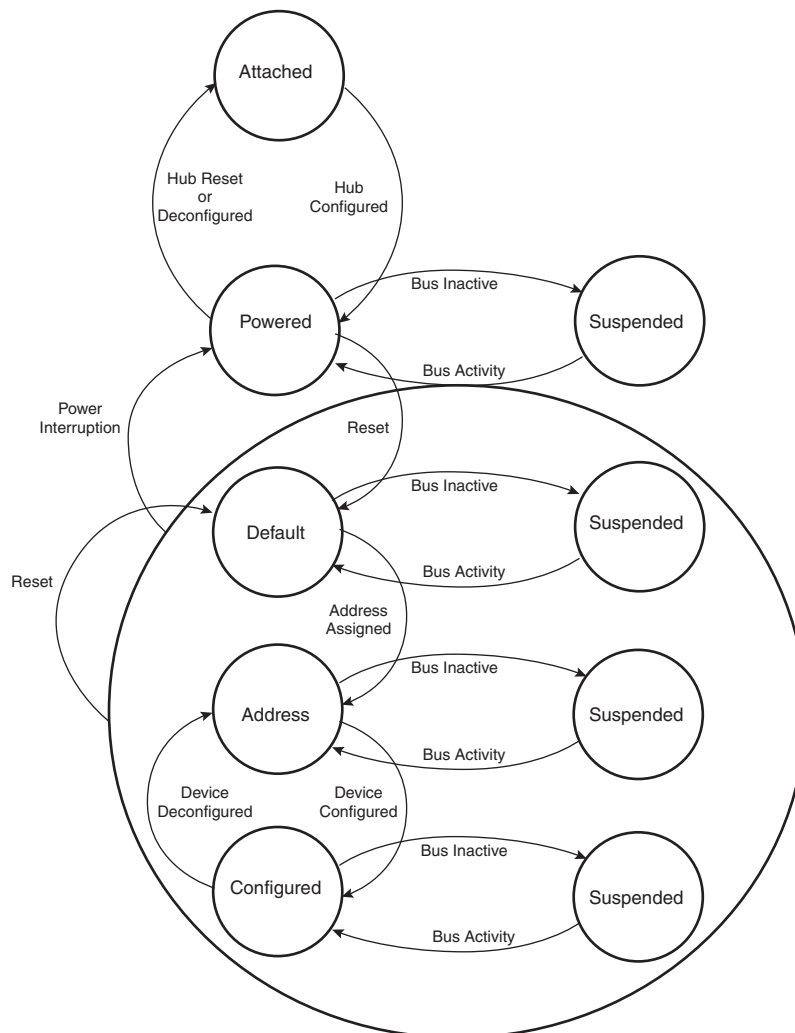

Movement from one state to another depends on the USB bus state or on standard requests sent through control transactions via the default endpoint (endpoint 0).

After a period of bus inactivity, the UDP device enters Suspend Mode. Accepting Suspend/Resume requests from the USB host is mandatory. Constraints in Suspend Mode are very strict for bus-powered applications; devices may not consume more than 500 μ A on the USB bus.

While in Suspend Mode, the host may wake up a device by sending a resume signal (bus activity) or a USB device may send a wake-up request to the host, e.g., waking up a PC by moving a USB mouse.

The wake-up feature is not mandatory for all devices and must be negotiated with the host.

34.5.3.1 *From Powered State to Default State*

After its connection to a USB host, the USB device waits for an end-of-bus reset. The USB host stops driving a reset state once it has detected the device's pull-up on DP. The unmasked flag ENDBUSRES is set in the register UDP_ISR and an interrupt is triggered. The UDP software enables the default endpoint, setting the EPEDS flag in the UDP_CSR[0] register and, optionally, enabling the interrupt for endpoint 0 by writing 1 to the UDP_IER register. The enumeration then begins by a control transfer.

34.5.3.2 *From Default State to Address State*

After a set address standard device request, the USB host peripheral enters the address state. Before this, it achieves the Status IN transaction of the control transfer, i.e., the UDP device sets its new address once the TXCOMP flag in the UDP_CSR[0] register has been received and cleared.

To move to address state, the driver software sets the FADDEN flag in the UDP_GLB_STATE, sets its new address, and sets the FEN bit in the UDP_FADDR register.

34.5.3.3 *From Address State to Configured State*

Once a valid Set Configuration standard request has been received and acknowledged, the device enables endpoints corresponding to the current configuration. This is done by setting the EPEDS and EPTYPE fields in the UDP_CSRx registers and, optionally, enabling corresponding interrupts in the UDP_IER register.

34.5.3.4 *Enabling Suspend*

When a Suspend (no bus activity on the USB bus) is detected, the RXSUSP signal in the UDP_ISR register is set. This triggers an interrupt if the corresponding bit is set in the UDP_IMR register.

This flag is cleared by writing to the UDP_ICR register. Then the device enters Suspend Mode. As an example, the microcontroller switches to slow clock, disables the PLL and main oscillator, and goes into Idle Mode. It may also switch off other devices on the board.

The USB device peripheral clocks may be switched off. However, the transceiver and the USB peripheral must not be switched off, otherwise the resume is not detected.

34.5.3.5 *Receiving a Host Resume*

In suspend mode, the USB transceiver and the USB peripheral must be powered to detect the RESUME. However, the USB device peripheral may not be clocked as the WAKEUP signal is asynchronous.

Once the resume is detected on the bus, the signal WAKEUP in the UDP_ISR is set. It may generate an interrupt if the corresponding bit in the UDP_IMR register is set. This interrupt may be used to wake-up the core, enable PLL and main oscillators and configure clocks. The WAKEUP bit must be cleared as soon as possible by setting WAKEUP in the UDP_ICR register.

34.5.3.6 *Sending an External Resume*

The External Resume is negotiated with the host and enabled by setting the ESR bit in the UDP_GLB_STATE. An asynchronous event on the ext_resume_pin of the peripheral generates a WAKEUP interrupt. On early versions of the USP peripheral, the K-state on the USB line is generated immediately. This means that the USB device must be able to answer to the host very quickly. On recent versions, the software sets the RMWUPE bit in the UDP_GLB_STATE register once it is ready to communicate with the host. The K-state on the bus is then generated.

The WAKEUP bit must be cleared as soon as possible by setting WAKEUP in the UDP_ICR register.

34.6 USB Device Port (UDP) User Interface

Table 34-3. USB Device Port Memory Map

Offset	Register	Name	Access	Reset State
0x000	Frame Number Register	UDP_FRM_NUM	Read	0x0000_0000
0x004	Global State Register	UDP_GLB_STAT	Read/Write	0x0000_0010
0x008	Function Address Register	UDP_FADDR	Read/Write	0x0000_0100
0x00C	Reserved	–	–	–
0x010	Interrupt Enable Register	UDP_IER	Write	
0x014	Interrupt Disable Register	UDP_IDR	Write	
0x018	Interrupt Mask Register	UDP_IMR	Read	0x0000_1200
0x01C	Interrupt Status Register	UDP_ISR	Read	0x0000_0000
0x020	Interrupt Clear Register	UDP_ICR	Write	
0x024	Reserved	–	–	–
0x028	Reset Endpoint Register	UDP_RST_EP	Read/Write	
0x02C	Reserved	–	–	–
0x030	Endpoint 0 Control and Status Register	UDP_CSR0	Read/Write	0x0000_0000
0x034	Endpoint 1 Control and Status Register	UDP_CSR1	Read/Write	0x0000_0000
0x038	Endpoint 2 Control and Status Register	UDP_CSR2	Read/Write	0x0000_0000
0x03C	Endpoint 3 Control and Status Register	UDP_CSR3	Read/Write	0x0000_0000
0x040	Endpoint 4 Control and Status Register	UDP_CSR4	Read/Write	0x0000_0000
0x044	Endpoint 5 Control and Status Register	UDP_CSR5	Read/Write	0x0000_0000
0x048	Reserved	–	–	–
0x04C	Reserved	–	–	–
0x050	Endpoint 0 FIFO Data Register	UDP_FDR0	Read/Write	0x0000_0000
0x054	Endpoint 1 FIFO Data Register	UDP_FDR1	Read/Write	0x0000_0000
0x058	Endpoint 2 FIFO Data Register	UDP_FDR2	Read/Write	0x0000_0000
0x05C	Endpoint 3 FIFO Data Register	UDP_FDR3	Read/Write	0x0000_0000
0x060	Endpoint 4 FIFO Data Register	UDP_FDR4	Read/Write	0x0000_0000
0x064	Endpoint 5 FIFO Data Register	UDP_FDR5	Read/Write	0x0000_0000
0x068	Reserved	–	–	–
0x06C	Reserved	–	–	–
0x074	Transceiver Control Register	UDP_TXVC	Read/Write	0x0000_0100
0x070	Reserved	–	–	–

34.6.1 UDP Frame Number Register

Register Name: UDP_FRM_NUM

Access Type: Read-only

31	30	29	28	27	26	25	24
---	---	---	---	---	---	---	---
23	22	21	20	19	18	17	16
-	-	-	-	-	-	FRM_OK	FRM_ERR
15	14	13	12	11	10	9	8
-	-	-	-	-	FRM_NUM		
7	6	5	4	3	2	1	0
FRM_NUM							

- **FRM_NUM[10:0]: Frame Number as Defined in the Packet Field Formats**

This 11-bit value is incremented by the host on a per frame basis. This value is updated at each start of frame.

Value Updated at the SOF_EOP (Start of Frame End of Packet).

- **FRM_ERR: Frame Error**

This bit is set at SOF_EOP when the SOF packet is received containing an error.

This bit is reset upon receipt of SOF_PID.

- **FRM_OK: Frame OK**

This bit is set at SOF_EOP when the SOF packet is received without any error.

This bit is reset upon receipt of SOF_PID (Packet Identification).

In the Interrupt Status Register, the SOF interrupt is updated upon receiving SOF_PID. This bit is set without waiting for EOP.

Note: In the 8-bit Register Interface, FRM_OK is bit 4 of FRM_NUM_H and FRM_ERR is bit 3 of FRM_NUM_L.



34.6.2 UDP Global State Register

Register Name: UDP_GLB_STAT

Access Type: Read/Write

31	30	29	28	27	26	25	24
–	–	–	–	–	–	–	–
23	22	21	20	19	18	17	16
–	–	–	–	–	–	–	–
15	14	13	12	11	10	9	8
–	–	–	–	–	–	–	–
7	6	5	4	3	2	1	0
–	–	–	RMWUPE	RSMINPR	ESR	CONFIG	FADDEN

This register is used to get and set the device state as specified in Chapter 9 of the *USB Serial Bus Specification, Rev. 1.1*.

• **FADDEN: Function Address Enable**

Read:

0 = Device is not in address state.

1 = Device is in address state.

Write:

0 = No effect, only a reset can bring back a device to the default state.

1 = Set device in address state. This occurs after a successful Set Address request. Beforehand, the USB_FADDR register must have been initialized with Set Address parameters. Set Address must complete the Status Stage before setting FADDEN. Please refer to chapter 9 of the *Universal Serial Bus Specification, Rev. 1.1* to get more details.

• **CONFIG: Configured**

Read:

0 = Device is not in configured state.

1 = Device is in configured state.

Write:

0 = Set device in a nonconfigured state

1 = Set device in configured state.

The device is set in configured state when it is in address state and receives a successful Set Configuration request. Please refer to Chapter 9 of the *Universal Serial Bus Specification, Rev. 1.1* to get more details.

• **ESR: Enable Send Resume**

0 = Disable the Remote Wake Up sequence.

1 = Remote Wake Up can be processed and the pin send_resume is enabled.

- **RSMINPR: A Resume Has Been Sent to the Host**

Read:

0 = No effect.

1 = A Resume has been received from the host during Remote Wake Up feature.

- **RMWUPE: Remote Wake Up Enable**

0 = Must be cleared after receiving any HOST packet or SOF interrupt.

1 = Enables the K-state on the USB cable if ESR is enabled.

34.6.3 UDP Function Address Register

Register Name: UDP_FADDR

Access Type: Read/Write

31	30	29	28	27	26	25	24
–	–	–	–	–	–	–	–
23	22	21	20	19	18	17	16
–	–	–	–	–	–	–	–
15	14	13	12	11	10	9	8
–	–	–	–	–	–	–	FEN
7	6	5	4	3	2	1	0
–	FADD						

- **FADD[6:0]: Function Address Value**

The Function Address Value must be programmed by firmware once the device receives a set address request from the host, and has achieved the status stage of the no-data control sequence. Please refer to the *Universal Serial Bus Specification, Rev. 1.1* to get more information. After power up, or reset, the function address value is set to 0.

- **FEN: Function Enable**

Read:

0 = Function endpoint disabled.

1 = Function endpoint enabled.

Write:

0 = Disable function endpoint.

1 = Default value.

The Function Enable bit (FEN) allows the microcontroller to enable or disable the function endpoints. The microcontroller sets this bit after receipt of a reset from the host. Once this bit is set, the USB device is able to accept and transfer data packets from and to the host.

34.6.4 UDP Interrupt Enable Register

Register Name: UDP_IER

Access Type: Write-only

31	30	29	28	27	26	25	24
–	–	–	–	–	–	–	–
23	22	21	20	19	18	17	16
–	–	–	–	–	–	–	–
15	14	13	12	11	10	9	8
–	–	WAKEUP	–	SOFINT	EXTRSM	RXRSM	RXSUSP
7	6	5	4	3	2	1	0
–	–	EP5INT	EP4INT	EP3INT	EP2INT	EP1INT	EPOINT

- **EP0INT: Enable Endpoint 0 Interrupt**
- **EP1INT: Enable Endpoint 1 Interrupt**
- **EP2INT: Enable Endpoint 2 Interrupt**
- **EP3INT: Enable Endpoint 3 Interrupt**
- **EP4INT: Enable Endpoint 4 Interrupt**
- **EP5INT: Enable Endpoint 5 Interrupt**
0 = No effect.
1 = Enable corresponding Endpoint Interrupt.
- **RXSUSP: Enable USB Suspend Interrupt**
0 = No effect.
1 = Enable USB Suspend Interrupt.
- **RXRSM: Enable USB Resume Interrupt**
0 = No effect.
1 = Enable USB Resume Interrupt.
- **EXTRSM: Enable External Resume Interrupt**
0 = No effect.
1 = Enable External Resume Interrupt.
- **SOFINT: Enable Start Of Frame Interrupt**
0 = No effect.
1 = Enable Start Of Frame Interrupt.
- **WAKEUP: Enable USB bus Wakeup Interrupt**

0 = No effect.

1 = Enable USB bus Interrupt.

34.6.5 UDP Interrupt Disable Register

Register Name: UDP_IDR

Access Type: Write-only

31	30	29	28	27	26	25	24
–	–	–	–	–	–	–	–
23	22	21	20	19	18	17	16
–	–	–	–	–	–	–	–
15	14	13	12	11	10	9	8
–	–	WAKEUP	–	SOFINT	EXTRSM	RXRSM	RXSUSP
7	6	5	4	3	2	1	0
–	–	EP5INT	EP4INT	EP3INT	EP2INT	EP1INT	EPOINT

- **EP0INT: Disable Endpoint 0 Interrupt**

- **EP1INT: Disable Endpoint 1 Interrupt**

- **EP2INT: Disable Endpoint 2 Interrupt**

- **EP3INT: Disable Endpoint 3 Interrupt**

- **EP4INT: Disable Endpoint 4 Interrupt**

- **EP5INT: Disable Endpoint 5 Interrupt**

0 = No effect.

1 = Disable corresponding Endpoint Interrupt.

- **RXSUSP: Disable USB Suspend Interrupt**

0 = No effect.

1 = Disable USB Suspend Interrupt.

- **RXRSM: Disable USB Resume Interrupt**

0 = No effect.

1 = Disable USB Resume Interrupt.

- **EXTRSM: Disable External Resume Interrupt**

0 = No effect.

1 = Disable External Resume Interrupt.

- **SOFINT: Disable Start Of Frame Interrupt**

0 = No effect.

1 = Disable Start Of Frame Interrupt

- **WAKEUP: Disable USB Bus Interrupt**

0 = No effect.

1 = Disable USB Bus Wakeup Interrupt.

34.6.6 UDP Interrupt Mask Register

Register Name: UDP_IMR

Access Type: Read-only

31	30	29	28	27	26	25	24
–	–	–	–	–	–	–	–
23	22	21	20	19	18	17	16
–	–	–	–	–	–	–	–
15	14	13	12	11	10	9	8
–	–	WAKEUP	–	SOFINT	EXTRSM	RXRSM	RXSUSP
7	6	5	4	3	2	1	0
–	–	EP5INT	EP4INT	EP3INT	EP2INT	EP1INT	EPOINT

- **EP0INT: Mask Endpoint 0 Interrupt**

- **EP1INT: Mask Endpoint 1 Interrupt**

- **EP2INT: Mask Endpoint 2 Interrupt**

- **EP3INT: Mask Endpoint 3 Interrupt**

- **EP4INT: Mask Endpoint 4 Interrupt**

- **EP5INT: Mask Endpoint 5 Interrupt**

0 = Corresponding Endpoint Interrupt is disabled.

1 = Corresponding Endpoint Interrupt is enabled.

- **RXSUSP: Mask USB Suspend Interrupt**

0 = USB Suspend Interrupt is disabled.

1 = USB Suspend Interrupt is enabled.

- **RXRSM: Mask USB Resume Interrupt.**

0 = USB Resume Interrupt is disabled.

1 = USB Resume Interrupt is enabled.

- **EXTRSM: Mask External Resume Interrupt**

0 = External Resume Interrupt is disabled.

1 = External Resume Interrupt is enabled.

- **SOFINT: Mask Start Of Frame Interrupt**

0 = Start of Frame Interrupt is disabled.

1 = Start of Frame Interrupt is enabled.

- **WAKEUP: USB Bus WAKEUP Interrupt**

0 = USB Bus Wakeup Interrupt is disabled.

1 = USB Bus Wakeup Interrupt is enabled.

Note: When the USB block is in suspend mode, the application may power down the USB logic. In this case, any USB HOST resume request that is made must be taken into account and, thus, the reset value of the RXRSM bit of the register USB_IMR is enabled.

34.6.7 UDP Interrupt Status Register

Register Name: UDP_ISR

Access Type: Read -only

31	30	29	28	27	26	25	24
–	–	–	–	–	–	–	–
23	22	21	20	19	18	17	16
–	–	–	–	–	–	–	–
15	14	13	12	11	10	9	8
–	–	WAKEUP	ENDBUSRES	SOFINT	EXTRSM	RXRSM	RXSUSP
7	6	5	4	3	2	1	0
–	–	EP5INT	EP4INT	EP3INT	EP2INT	EP1INT	EP0INT

- **EP0INT: Endpoint 0 Interrupt Status**

0 = No Endpoint0 Interrupt pending.

1 = Endpoint0 Interrupt has been raised.

Several signals can generate this interrupt. The reason can be found by reading UDP_CSR0:

RXSETUP set to 1

RX_DATA_BK0 set to 1

RX_DATA_BK1 set to 1

TXCOMP set to 1

STALLSENT set to 1

EP0INT is a sticky bit. Interrupt remains valid until EP0INT is cleared by writing in the corresponding UDP_CSR0 bit.

- **EP1INT: Endpoint 1 Interrupt Status**

0 = No Endpoint1 Interrupt pending.

1 = Endpoint1 Interrupt has been raised.

Several signals can generate this interrupt. The reason can be found by reading UDP_CSR1:

RXSETUP set to 1

RX_DATA_BK0 set to 1

RX_DATA_BK1 set to 1

TXCOMP set to 1

STALLSENT set to 1

EP1INT is a sticky bit. Interrupt remains valid until EP1INT is cleared by writing in the corresponding UDP_CSR1 bit.

- **EP2INT: Endpoint 2 Interrupt Status**

0 = No Endpoint2 Interrupt pending.

1 = Endpoint2 Interrupt has been raised.

Several signals can generate this interrupt. The reason can be found by reading UDP_CSR2:

RXSETUP set to 1

RX_DATA_BK0 set to 1

RX_DATA_BK1 set to 1

TXCOMP set to 1

STALLSENT set to 1

EP2INT is a sticky bit. Interrupt remains valid until EP2INT is cleared by writing in the corresponding UDP_CSR2 bit.

- **EP3INT: Endpoint 3 Interrupt Status**

0 = No Endpoint3 Interrupt pending.

1 = Endpoint3 Interrupt has been raised.

Several signals can generate this interrupt. The reason can be found by reading UDP_CSR3:

RXSETUP set to 1

RX_DATA_BK0 set to 1

RX_DATA_BK1 set to 1

TXCOMP set to 1

STALLSENT set to 1

EP3INT is a sticky bit. Interrupt remains valid until EP3INT is cleared by writing in the corresponding UDP_CSR3 bit.

- **EP4INT: Endpoint 4 Interrupt Status**

0 = No Endpoint4 Interrupt pending.

1 = Endpoint4 Interrupt has been raised.

Several signals can generate this interrupt. The reason can be found by reading UDP_CSR4:

RXSETUP set to 1

RX_DATA_BK0 set to 1

RX_DATA_BK1 set to 1

TXCOMP set to 1

STALLSENT set to 1

EP4INT is a sticky bit. Interrupt remains valid until EP4INT is cleared by writing in the corresponding UDP_CSR4 bit.

- **EP5INT: Endpoint 5 Interrupt Status**

0 = No Endpoint5 Interrupt pending.

1 = Endpoint5 Interrupt has been raised.

Several signals can generate this interrupt. The reason can be found by reading UDP_CSR5:

RXSETUP set to 1
RX_DATA_BK0 set to 1
RX_DATA_BK1 set to 1
TXCOMP set to 1
STALLSENT set to 1

EP5INT is a sticky bit. Interrupt remains valid until EP5INT is cleared by writing in the corresponding UDP_CSR5 bit.

- **RXSUSP: USB Suspend Interrupt Status**

0 = No USB Suspend Interrupt pending.

1 = USB Suspend Interrupt has been raised.

The USB device sets this bit when it detects no activity for 3ms. The USB device enters Suspend mode.

- **RXRSM: USB Resume Interrupt Status**

0 = No USB Resume Interrupt pending.

1 = USB Resume Interrupt has been raised.

The USB device sets this bit when a USB resume signal is detected at its port.

- **EXTRSM: External Resume Interrupt Status**

0 = No External Resume Interrupt pending.

1 = External Resume Interrupt has been raised.

This interrupt is raised when, in suspend mode, an asynchronous rising edge on the send_resume is detected.

If RMWUPE = 1, a resume state is sent in the USB bus.

- **SOFINT: Start of Frame Interrupt Status**

0 = No Start of Frame Interrupt pending.

1 = Start of Frame Interrupt has been raised.

This interrupt is raised each time a SOF token has been detected. It can be used as a synchronization signal by using isochronous endpoints.

- **ENDBUSRES: End of BUS Reset Interrupt Status**

0 = No End of Bus Reset Interrupt pending.

1 = End of Bus Reset Interrupt has been raised.

This interrupt is raised at the end of a USB reset sequence. The USB device must prepare to receive requests on the end-point 0. The host starts the enumeration, then performs the configuration.

- **WAKEUP: USB Resume Interrupt Status**

0 = No Wakeup Interrupt pending.

1 = A Wakeup Interrupt (USB Host Sent a RESUME or RESET) occurred since the last clear.

34.6.8 UDP Interrupt Clear Register

Register Name: UDP_ICR

Access Type: Write-only

31	30	29	28	27	26	25	24
–	–	–	–	–	–	–	–
23	22	21	20	19	18	17	16
–	–	–	–	–	–	–	–
15	14	13	12	11	10	9	8
–	–	WAKEUP	ENDBUSRES	SOFINT	EXTRSM	RXRSM	RXSUSP
7	6	5	4	3	2	1	0
–	–	–	–	–	–	–	–

• **RXSUSP: Clear USB Suspend Interrupt**

0 = No effect.

1 = Clear USB Suspend Interrupt.

• **RXRSM: Clear USB Resume Interrupt**

0 = No effect.

1 = Clear USB Resume Interrupt.

• **EXTRSM: Clear External Resume Interrupt**

0 = No effect.

1 = Clear External Resume Interrupt.

• **SOFINT: Clear Start Of Frame Interrupt**

0 = No effect.

1 = Clear Start Of Frame Interrupt.

• **ENDBUSRES: Clear End of Bus Reset Interrupt**

0 = No effect.

1 = Clear End of Bus Reset Interrupt.

• **WAKEUP: Clear Wakeup Interrupt**

0 = No effect.

1 = Clear Wakeup Interrupt.

34.6.9 UDP Reset Endpoint Register

Register Name: UDP_RST_EP

Access Type: Read/Write

31	30	29	28	27	26	25	24
–	–	–	–	–	–	–	–
23	22	21	20	19	18	17	16
–	–	–	–	–	–	–	–
15	14	13	12	11	10	9	8
–	–	–	–	–	–	–	–
7	6	5	4	3	2	1	0
–	–	EP5	EP4	EP3	EP2	EP1	EP0

- **EP0: Reset Endpoint 0**
- **EP1: Reset Endpoint 1**
- **EP2: Reset Endpoint 2**
- **EP3: Reset Endpoint 3**
- **EP4: Reset Endpoint 4**
- **EP5: Reset Endpoint 5**

This flag is used to reset the FIFO associated with the endpoint and the bit RXBYTECOUNT in the register UDP_CSRx. It also resets the data toggle to DATA0. It is useful after removing a HALT condition on a BULK endpoint. Refer to Chapter 5.8.5 in the *USB Serial Bus Specification, Rev. 1.1*.

Warning: This flag must be cleared at the end of the reset. It does not clear UDP_CSRx flags.

0 = No reset.

1 = Forces the corresponding endpoint FIFO pointers to 0, therefore RXBYTECNT field is read at 0 in UDP_CSRx register.

34.6.10 UDP Endpoint Control and Status Register

Register Name: UDP_CSRx [x = 0..7]

Access Type: Read/Write

31	30	29	28	27	26	25	24
–	–	–	–	–	RXBYTECNT		
23	22	21	20	19	18	17	16
RXBYTECNT							
15	14	13	12	11	10	9	8
EPEDS	–	–	–	DTGLE	EPTYPE		
7	6	5	4	3	2	1	0
DIR	RX_DATA_ BK1	FORCE STALL	TXPKTRDY	STALLSENT ISOERROR	RXSETUP	RX_DATA_ BK0	TXCOMP

WARNING: Due to a synchronization between MCK and UDPCK, the software application must wait for the end of the write operation before executing another write by polling the bits which must be set/cleared.

///
Clear flags of UDP UDP_CSR register and waits for synchronization

```
#define Udp_ep_clr_flag(pInterface, endpoint, flags) { \
pInterface->UDP_CSR[endpoint] &= ~(flags); \
while ( (pInterface->UDP_CSR[endpoint] & (flags)) == (flags) ); \
}
```

///
Set flags of UDP UDP_CSR register and waits for synchronization

```
#define Udp_ep_set_flag(pInterface, endpoint, flags) { \
pInterface->UDP_CSR[endpoint] |= (flags); \
while ( (pInterface->UDP_CSR[endpoint] & (flags)) != (flags) ); \
}
```

- **TXCOMP: Generates an IN packet with data previously written in the DPR**

This flag generates an interrupt while it is set to one.

Write (Cleared by the firmware)

0 = Clear the flag, clear the interrupt.

1 = No effect.

Read (Set by the USB peripheral)

0 = Data IN transaction has not been acknowledged by the Host.

1 = Data IN transaction is achieved, acknowledged by the Host.

After having issued a Data IN transaction setting TXPKTRDY, the device firmware waits for TXCOMP to be sure that the host has acknowledged the transaction.

- **RX_DATA_BK0: Receive Data Bank 0**

This flag generates an interrupt while it is set to one.

Write (Cleared by the firmware)

0 = Notify USB peripheral device that data have been read in the FIFO's Bank 0.

1 = No effect.

Read (Set by the USB peripheral)

0 = No data packet has been received in the FIFO's Bank 0

1 = A data packet has been received, it has been stored in the FIFO's Bank 0.

When the device firmware has polled this bit or has been interrupted by this signal, it must transfer data from the FIFO to the microcontroller memory. The number of bytes received is available in RXBYTCENT field. Bank 0 FIFO values are read through the UDP_FDRx register. Once a transfer is done, the device firmware must release Bank 0 to the USB peripheral device by clearing RX_DATA_BK0.

- **RXSETUP: Sends STALL to the Host (Control endpoints)**

This flag generates an interrupt while it is set to one.

Read

0 = No setup packet available.

1 = A setup data packet has been sent by the host and is available in the FIFO.

Write

0 = Device firmware notifies the USB peripheral device that it has read the setup data in the FIFO.

1 = No effect.

This flag is used to notify the USB device firmware that a valid Setup data packet has been sent by the host and successfully received by the USB device. The USB device firmware may transfer Setup data from the FIFO by reading the UDP_FDRx register to the microcontroller memory. Once a transfer has been done, RXSETUP must be cleared by the device firmware.

Ensuing Data OUT transactions is not accepted while RXSETUP is set.

- **STALLSENT: Stall sent (Control, Bulk Interrupt endpoints)/ ISOERROR (Isochronous endpoints)**

This flag generates an interrupt while it is set to one.

STALLSENT: this ends a STALL handshake

Read

0 = the host has not acknowledged a STALL.

1 = host has acknowledge the stall.

Write

0 = reset the STALLSENT flag, clear the interrupt.

1 = No effect.

This is mandatory for the device firmware to clear this flag. Otherwise the interrupt remains.

Please refer to chapters 8.4.4 and 9.4.5 of the *Universal Serial Bus Specification, Rev. 1.1* to get more information on the STALL handshake.

ISOERROR: a CRC error has been detected in an isochronous transfer

Read

0 = No error in the previous isochronous transfer.

1 = CRC error has been detected, data available in the FIFO are corrupted.

Write

0 = reset the ISOERROR flag, clear the interrupt.

1 = No effect.

- **TXPKTRDY: Transmit Packet Ready**

This flag is cleared by the USB device.

This flag is set by the USB device firmware.

Read

0 = Data values can be written in the FIFO.

1 = Data values can not be written in the FIFO.

Write

0 = No effect.

1 = A new data payload is has been written in the FIFO by the firmware and is ready to be sent.

This flag is used to generate a Data IN transaction (device to host). Device firmware checks that it can write a data payload in the FIFO, checking that TXPKTRDY is cleared. Transfer to the FIFO is done by writing in the UDP_FDRx register. Once the data payload has been transferred to the FIFO, the firmware notifies the USB device setting TXPKTRDY to one. USB bus transactions can start. TXCOMP is set once the data payload has been received by the host.

- **FORCESTALL: Force Stall (used by Control, Bulk and Isochronous endpoints)**

Write-only

0 = No effect.

1 = Send STALL to the host.

Please refer to chapters 8.4.4 and 9.4.5 of the *Universal Serial Bus Specification, Rev. 1.1* to get more information on the STALL handshake.

Control endpoints: during the data stage and status stage, this indicates that the microcontroller can not complete the request.

Bulk and interrupt endpoints: notify the host that the endpoint is halted.

The host acknowledges the STALL, device firmware is notified by the STALLSENT flag.

- **RX_DATA_BK1: Receive Data Bank 1 (only used by endpoints with ping-pong attributes)**

This flag generates an interrupt while it is set to one.

Write (Cleared by the firmware)

0 = Notify USB device that data have been read in the FIFO's Bank 1.

1 = No effect.

Read (Set by the USB peripheral)

0 = No data packet has been received in the FIFO's Bank 1.

1 = A data packet has been received, it has been stored in FIFO's Bank 1.

When the device firmware has polled this bit or has been interrupted by this signal, it must transfer data from the FIFO to microcontroller memory. The number of bytes received is available in RXBYTECNT field. Bank 1 FIFO values are read through UDP_FDRx register. Once a transfer is done, the device firmware must release Bank 1 to the USB device by clearing RX_DATA_BK1.

- **DIR: Transfer Direction (only available for control endpoints)**

Read/Write

0 = Allow Data OUT transactions in the control data stage.

1 = Enable Data IN transactions in the control data stage.

Please refer to Chapter 8.5.2 of the *Universal Serial Bus Specification, Rev. 1.1* to get more information on the control data stage.

This bit must be set before UDP_CSRx/RXSETUP is cleared at the end of the setup stage. According to the request sent in the setup data packet, the data stage is either a device to host (DIR = 1) or host to device (DIR = 0) data transfer. It is not necessary to check this bit to reverse direction for the status stage.

- **EPTYPE[2:0]: Endpoint Type**

Read/Write

000	Control
001	Isochronous OUT
101	Isochronous IN
010	Bulk OUT
110	Bulk IN
011	Interrupt OUT
111	Interrupt IN

- **DTGLE: Data Toggle**

Read-only

0 = Identifies DATA0 packet.

1 = Identifies DATA1 packet.

Please refer to Chapter 8 of the *Universal Serial Bus Specification, Rev. 1.1* to get more information on DATA0, DATA1 packet definitions.

- **EPEDS: Endpoint Enable Disable**

Read

0 = Endpoint disabled.

1 = Endpoint enabled.

Write

0 = Disable endpoint.

1 = Enable endpoint.

- **RXBYTECNT[10:0]: Number of Bytes Available in the FIFO**

Read-only.

When the host sends a data packet to the device, the USB device stores the data in the FIFO and notifies the microcontroller. The microcontroller can load the data from the FIFO by reading RXBYTECENT bytes in the UDP_FDRx register.

34.6.11 UDP FIFO Data Register

Register Name: UDP_FDRx [x = 0..7]

Access Type: Read/Write

31	30	29	28	27	26	25	24
–	–	–	–	–	–	–	–
23	22	21	20	19	18	17	16
–	–	–	–	–	–	–	–
15	14	13	12	11	10	9	8
–	–	–	–	–	–	–	–
7	6	5	4	3	2	1	0
FIFO_DATA							

- **FIFO_DATA[7:0]: FIFO Data Value**

The microcontroller can push or pop values in the FIFO through this register.

RXBYTECNT in the corresponding UDP_CSRx register is the number of bytes to be read from the FIFO (sent by the host).

The maximum number of bytes to write is fixed by the Max Packet Size in the Standard Endpoint Descriptor. It can not be more than the physical memory size associated to the endpoint. Please refer to the *Universal Serial Bus Specification, Rev. 1.1* to get more information.

34.6.12 UDP Transceiver Control Register

Register Name: UDP_TXVC

Access Type: Read/Write

31	30	29	28	27	26	25	24
–	–	–	–	–	–	–	–
23	22	21	20	19	18	17	16
–	–	–	–	–	–	–	–
15	14	13	12	11	10	9	8
–	–	–	–	–	–	–	TXVDIS
7	6	5	4	3	2	1	0
–	–	–	–	–	–	–	–

- **TXVDIS: Transceiver Disable**

When UDP is disabled, power consumption can be reduced significantly by disabling the embedded transceiver. This can be done by setting TXVDIS field.

To enable the transceiver, TXVDIS must be cleared.

35. USB Host Port (UHP)

35.1 Overview

The USB Host Port interfaces the USB with the host application. It handles Open HCI protocol (Open Host Controller Interface) as well as USB v2.0 Full-speed and Low-speed protocols. It also provides a simple Read/Write protocol on the ASB.

The USB Host Port integrates a root hub and transceivers on downstream ports. It provides several high-speed half-duplex serial communication ports at a baud rate of 12 Mbit/s. Up to 127 USB devices (printer, camera, mouse, keyboard, disk, etc.) and the USB hub can be connected to the USB host in the USB “tiered star” topology.

The USB Host Port controller is fully compliant with the Open HCI specification. The standard OHCI USB stack driver can be easily ported to ATMEL’s architecture in the same way all existing class drivers run without hardware specialization.

This means that all standard class devices are automatically detected and available to the user application. As an example, integrating an HID (Human Interface Device) class driver provides a plug & play feature for all USB keyboards and mice.

Key features of the USB Host Port are:

- Compliance with Open HCI Rev 1.0 Specification
- Compliance with USB V2.0 Full Speed and Low Speed Specification
- Supports Both Low-speed 1.5 Mbps and Full-speed 12 Mbps USB devices
- Root Hub Integrated with Two Downstream USB Ports
- Embedded USB Transceivers (Number of Transceivers is Product Dependant)
- Supports Power Management
- Operates as a Master on the ASB Bus

35.2 Block Diagram

Figure 35-1. USB Host Port Block Diagram

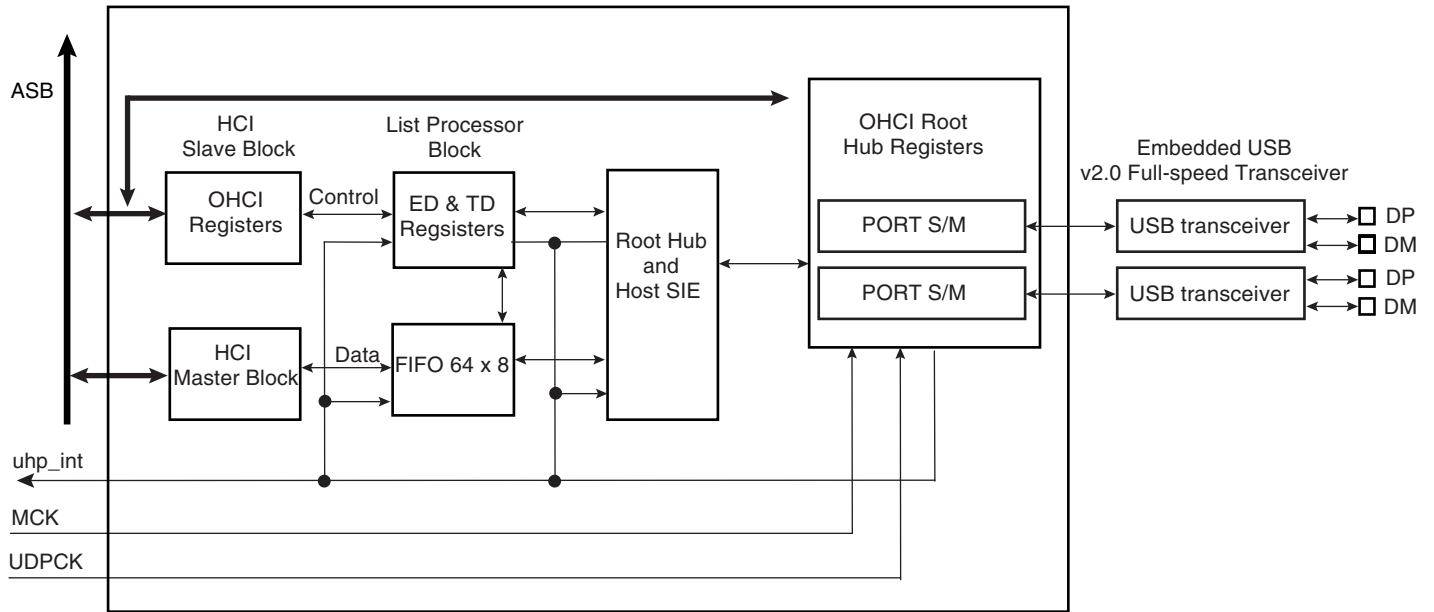

Access to the USB host operational registers is achieved through the ASB bus interface. The Open HCI host controller initializes master DMA transfers with the ASB bus as follows:

- Fetches endpoint descriptors and transfer descriptors
- Access to endpoint data from system memory
- Access to the HC communication area
- Write status and retire transfer Descriptor

Memory access errors (abort, misalignment) lead to an “UnrecoverableError” indicated by the corresponding flag in the host controller operational registers.

All of the ASB memory map is accessible to the USB host master DMA. Thus there is no need to define a dedicated physical memory area to the USB host.

The USB root hub is integrated in the USB host. Several USB downstream ports are available. The number of downstream ports can be determined by the software driver reading the root hub’s operational registers. Device connection is automatically detected by the USB host port logic.

Warning: a pull-down must be connected to DP on the board. Otherwise The USB host will permanently detect a device connection on this port.

USB physical transceivers are integrated in the product and driven by the root hub’s ports.

Over current protection on ports can be activated by the USB host controller. Atmel’s standard product does not dedicate pads to external over current protection.

35.3 Product Dependencies

35.3.1 I/O Lines

DPs and DMs are not controlled by any PIO controllers. The embedded USB physical transceivers are controlled by the USB host controller.

35.3.2 Power Management

The USB host controller requires a 48 MHz clock. This clock must be generated by a PLL with a correct accuracy of $\pm 0.25\%$.

Thus the USB device peripheral receives two clocks from the Power Management Controller (PMC): the master clock MCK used to drive the peripheral user interface (MCK domain) and the UHPCLK 48 MHz clock used to interface with the bus USB signals (Recovered 12 MHz domain).

35.3.3 Interrupt

The USB host interface has an interrupt line connected to the Advanced Interrupt Controller (AIC).

Handling USB host interrupts requires programming the AIC before configuring the UHP.

35.4 Functional Description

Please refer to the Open Host Controller Interface Specification for USB Release 1.0.a.

35.4.1 Host Controller Interface

There are two communication channels between the Host Controller and the Host Controller Driver. The first channel uses a set of operational registers located on the USB Host Controller. The Host Controller is the target for all communications on this channel. The operational registers contain control, status and list pointer registers. They are mapped in the ASB memory mapped area. Within the operational register set there is a pointer to a location in the processor address space named the Host Controller Communication Area (HCCA). The HCCA is the second communication channel. The host controller is the master for all communication on this channel. The HCCA contains the head pointers to the interrupt Endpoint Descriptor lists, the head pointer to the done queue and status information associated with start-of-frame processing.

The basic building blocks for communication across the interface are Endpoint Descriptors (ED, 4 double words) and Transfer Descriptors (TD, 4 or 8 double words). The host controller assigns an Endpoint Descriptor to each endpoint in the system. A queue of Transfer Descriptors is linked to the Endpoint Descriptor for the specific endpoint.

Figure 35-2. USB Host Communication Channels

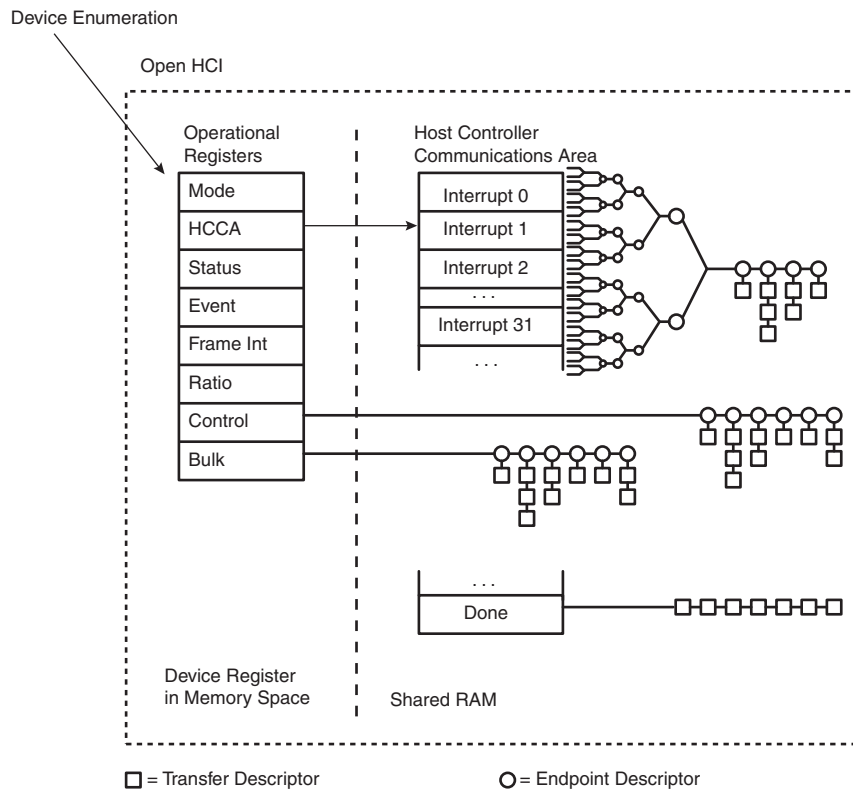

35.4.2 Host Controller Driver

Figure 35-3. USB Host Drivers

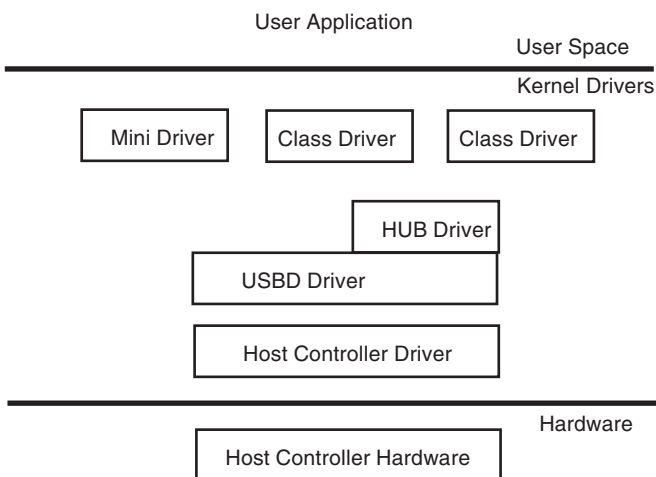

USB Handling is done through several layers as follows:

- Host controller hardware and serial engine: Transmit and receive USB data on the bus.
- Host controller driver: Drives the Host controller hardware and handle the USB protocol
- USB Bus driver and hub driver: Handles USB commands and enumeration. Offers a hardware independent interface.
- Mini driver: Handles device specific commands.

Class driver: handles standard devices. This acts as a generic driver for a class of devices, for example the HID driver.

35.5 Typical Connection

Figure 35-4. Board Schematic to Interface UHP Device Controller

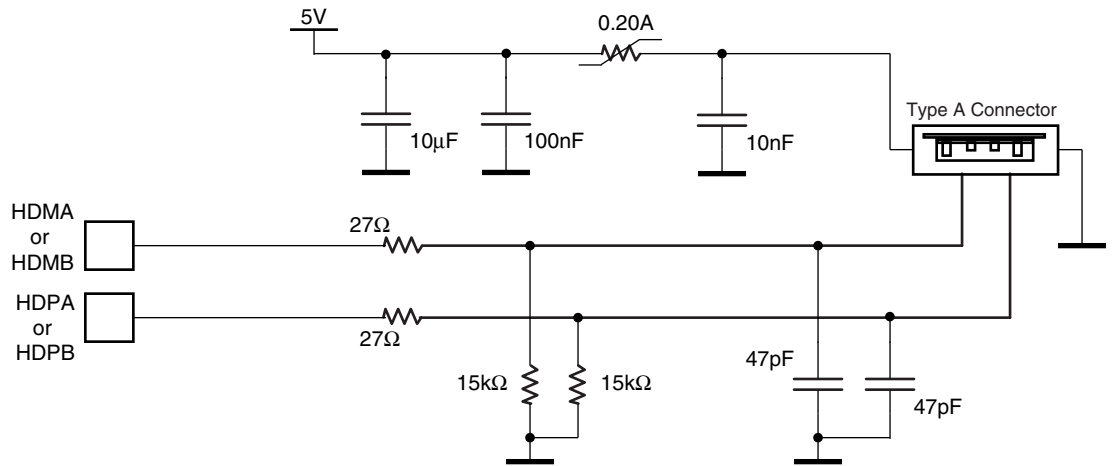

As device connection is automatically detected by the USB host port logic, a pull-down must be connected on DP and DM on the board. Otherwise the USB host will permanently detect a device connection on this port.

36. Ethernet MAC (EMAC)

36.1 Overview

The Ethernet MAC is the hardware implementation of the MAC sub-layer OSI reference model between the physical layer (PHY) and the logical link layer (LLC). It controls the data exchange between a host and a PHY layer according to Ethernet IEEE 802.3u data frame format. The Ethernet MAC contains the required logic and transmit and receive FIFOs for DMA management. In addition, it is interfaced through MDIO/MDC pins for PHY layer management.

The Ethernet MAC can transfer data in media-independent interface (MII) or reduced media-independent interface (RMII) modes depending on the pinout configuration.

The aim of the reduced interface is to lower the pin count for a switch product that can be connected to multiple PHY interfaces. The characteristics specific to RMII mode are:

- Single clock at 50 MHz frequency
- Reduction of required control pins
- Reduction of data paths to di-bit (2-bit wide) by doubling clock frequency
- 10 Mbits/sec. and 100 Mbits/sec. data capability

The major features of the EMAC are:

- Compatibility with IEEE Standard 802.3
- 10 and 100 Mbits per second data throughput capability
- Full- and half-duplex operation
- MII or RMII interface to the physical layer
- Register interface to address, status and control registers
- DMA interface
- Interrupt generation to signal receive and transmit completion
- 28-byte transmit and 28-byte receive FIFOs
- Automatic pad and CRC generation on transmitted frames
- Address checking logic to recognize four 48-bit addresses
- Supports promiscuous mode where all valid frames are copied to memory
- Supports physical layer management through MDIO interface control of alarm and update time/calendar data in

36.2 Block Diagram

Figure 36-1. Block Diagram

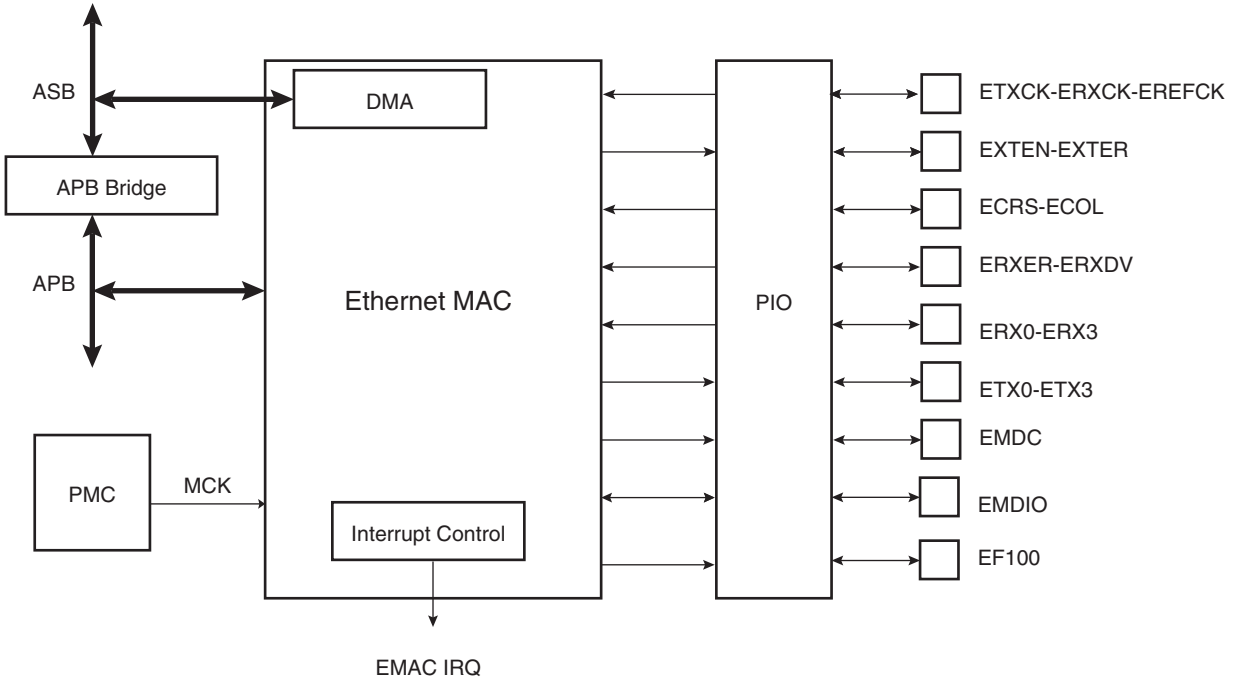

36.3 Application Block Diagram

Figure 36-2. Ethernet MAC Application Block Diagram

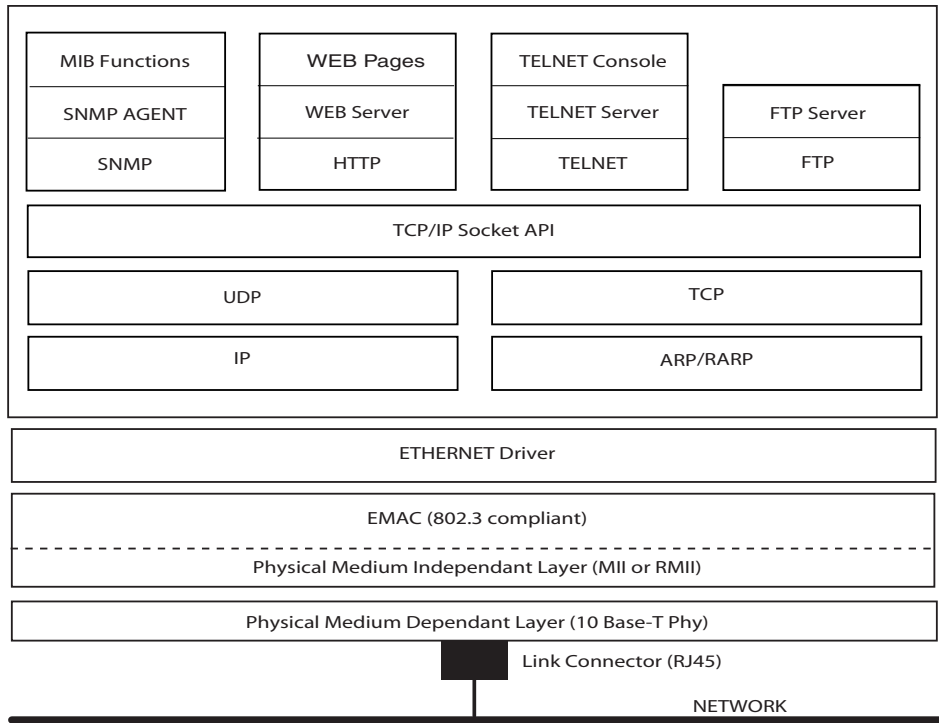

36.4 Product Dependencies

36.4.1 I/O Lines

The pins used for interfacing the compliant external devices may be multiplexed with PIO lines. The programmer must first program the PIO controllers to assign the EMAC pins to their peripheral functions. In RMII mode, unused pins (see [Table 36-1: MII/RMII Signal Mapping](#)) can be used as general I/O lines.

36.4.2 Power Management

The EMAC may be clocked through the Power Management Controller (PMC), so the programmer must first configure the PMC to enable the EMAC clock.

If not used, about 400 μ A current consumption can be saved by switching the EMAC in Local Loopback Mode with the following sequence:

- EMAC clock is enabled
 - write 0x1000000 in PMC_PCER
- EMAC Local Loopback is enabled
 - set bit 1 in EMAC_CTL
- EMAC clock is disabled
 - write 0x1000000 in PMC_PCDR

36.4.3 Interrupt

The EMAC has an interrupt line connected to the Advanced Interrupt Controller (AIC). Handling the EMAC interrupt requires programming the AIC before configuring the EMAC.

36.5 Functional Description

The Ethernet Media Access Control (EMAC) engine is fully compatible with the IEEE 802.3 Ethernet standard. It manages frame transmission and reception including collision detection, preamble generation and detection, CRC control and generation and transmitted frame padding.

The MAC functions are:

- Frame encapsulation and decapsulation
- Error detection
- Media access management (MII, RMII)

Figure 36-3. EMAC Functional Block Diagram

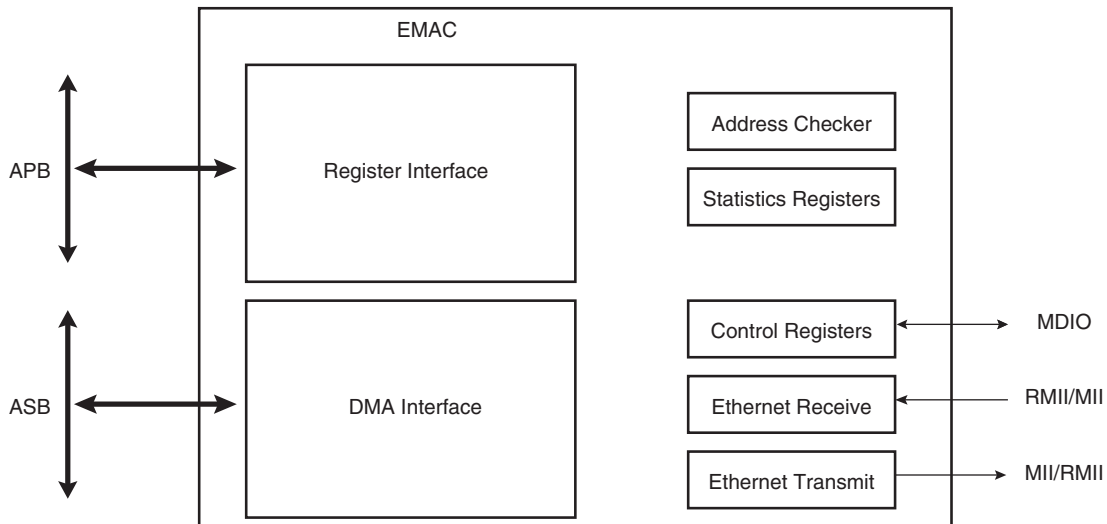

36.5.1 Media Independent Interface

36.5.1.1 General

The Ethernet MAC is capable of interfacing to both RMII and MII Interfaces. The RMII bit in the ETH_CFG register controls the interface that is selected. When this bit is set, the RMII interface is selected, else the MII interface is selected.

The MII and RMII interface are capable of both 10Mb/s and 100Mb/s data rates as described in the IEEE 802.3u standard. The signals used by the MII and RMII interfaces are described in the [Table 36-1](#).

Table 36-1. Pin Configurations

Pin Name	MII	RMII
ETXCK_REFCK	ETXCK: Transmit Clock	REFCK: Reference Clock
ECRS_ECRSDV	ECRS: Carrier Sense	ECRSDV: Carrier Sense/Data Valid
ECOL	ECOL: Collision Detect	
ERXDV	ERXDV: Data Valid	
ERX0 - ERX3	ERX0 - ERX3: 4-bit Receive Data	ERX0 - ERX1: 2-bit Receive Data
ERXER	ERXER: Receive Error	ERXER: Receive Error
ERXCK	ERXCK: Receive Clock	
ETXEN	ETXEN: Transmit Enable	ETXEN: Transmit Enable
ETX0-ETX3	ETX0 - ETX3: 4-bit Transmit Data	ETX0 - ETX1: 2-bit Transmit Data
ETXER	ETXER: Transmit Error	

The intent of the RMII is to provide a reduced pin count alternative to the IEEE 802.3u MII. It uses 2 bits for transmit (ETX0 and ETX1) and two bits for receive (ERX0 and ERX1). There is a Transmit Enable (ETXEN), a Receive Error (ERXER), a Carrier Sense (ECRS_DV), and a 50 MHz Reference Clock (ETXCK_REFCK) for 100Mb/s data rate.

36.5.1.2 RMII Transmit and Receive Operation

The same signals are used internally for both the RMII and the MII operations. The RMII maps these signals in a more pin-efficient manner. The transmit and receive bits are converted from a 4-bit parallel format to a 2-bit parallel scheme that is clocked at twice the rate. The carrier sense and data valid signals are combined into the ECRS_ECRSDV signal. This signal contains information on carrier sense, FIFO status, and validity of the data. Transmit error bit (ETXER) and collision detect (ECOL) are not used in RMII mode.

36.5.2 Transmit/Receive Operation

A standard IEEE 802.3 packet consists of the following fields: preamble, start of frame delimiter (SFD), destination address (DA), source address (SA), length, data (Logical Link Control Data) and frame check sequence CRC32 (FCS).

Table 36-2. Packet Format

Preamble		Frame ⁽¹⁾					
Alternating 1s/0s	SFD	DA	SA	Length/type	LLC Data	PAD	FCS
Up to 7 bytes	1 byte	6 bytes	6 bytes	2 bytes			4 bytes

Note: Frame Length between 64 bytes and 1518 bytes.

The packets are Manchester-encoded and -decoded and transferred serially using NRZ data with a clock. All fields are of fixed length except for the data field. The MAC generates and appends the preamble, SFD and CRC fields during transmission.

The preamble and SFD fields are stripped during reception.

36.5.2.1 *Preamble and Start of Frame Delimiter (SFD)*

The preamble field is used to acquire bit synchronization with an incoming packet. When transmitted, each packet contains 62 bits of alternating 1,0 preamble. Some of this preamble is lost as the packet travels through the network. Byte alignment is performed with the Start of Frame Delimiter (SFD) pattern that consists of two consecutive 1's.

36.5.2.2 *Destination Address*

The destination address (DA) indicates the destination of the packet on the network and is used to filter unwanted packets. There are three types of address formats: physical, multicast and broadcast. The physical address is a unique address that corresponds only to a single node. All physical addresses have an MSB of 0.

Multicast addresses begin with an MSB of 1. The MAC filters multicast addresses using a standard hashing algorithm that maps all multicast addresses into a 6-bit value. This 6-bit value indexes a 64-bit array that filters the value. If the address consists of all ones, it is a broadcast address, indicating that the packet is intended for all nodes.

36.5.2.3 *Source Address*

The source address (SA) is the physical address of the node that sent the packet. Source addresses cannot be multicast or broadcast addresses. This field is passed to buffer memory.

36.5.2.4 *Length/Type*

If the value of this field is less than or equal to 1500, then the Length/Type field indicates the number of bytes in the subsequent LLC Data field. If the value of this field is greater than or equal to 1536, then the Length/Type field indicates the nature of the MAC client protocol (protocol type).

36.5.2.5 *LLC Data*

The data field consists of anywhere from 46 to 1500 bytes. Messages longer than 1500 bytes need to be broken into multiple packets. Messages shorter than 46 bytes require appending a pad to bring the data field to the minimum length of 46 bytes. If the data field is padded, the number of valid data bytes is indicated in the length field.

36.5.2.6 *FCS Field*

The Frame Check Sequence (FCS) is a 32-bit CRC field, calculated and appended to a packet during transmission to allow detection of errors when a packet is received. During reception, error free packets result in a specific pattern in the CRC generator. Packets with improper CRC will be rejected.

36.5.3 **Frame Format Extensions**

The original Ethernet standards defined the minimum frame size as 64 bytes and the maximum as 1518 bytes. These numbers include all bytes from the Destination MAC Address field through the Frame Check Sequence field. The Preamble and Start Frame Delimiter fields are not included when quoting the size of a frame. The IEEE 802.3ac standard extended the maximum

allowable frame size to 1522 bytes to allow a VLAN tag to be inserted into the Ethernet frame format. The bit BIG defined in the ETH_CFG register aims to process packet with VLAN tag.

The VLAN protocol permits insertion of an identifier, or tag, into the Ethernet frame format to identify the VLAN to which the frame belongs. It allows frames from stations to be assigned to logical groups. This provides various benefits, such as easing network administration, allowing formation of work groups, enhancing network security, and providing a means of limiting broadcast domains (refer to IEEE standard 802.1Q for definition of the VLAN protocol). The 802.3ac standard defines only the implementation details of the VLAN protocol that are specific to Ethernet.

If present, the 4-byte VLAN tag is inserted into the Ethernet frame between the Source MAC Address field and the Length field. The first 2-bytes of the VLAN tag consist of the “802.1Q Tag Type” and are always set to a value of 0x8100. The 0x8100 value is a reserved Length/Type field assignment that indicates the presence of the VLAN tag, and signals that the traditional Length/Type field can be found at an offset of four bytes further into the frame. The last two bytes of the VLAN tag contain the following information:

- The first three bits are a User Priority Field that may be used to assign a priority level to the Ethernet frame.
- The following one bit is a Canonical Format Indicator (CFI) used in Ethernet frames to indicate the presence of a Routing Information Field (RIF).
- The last twelve bits are the VLAN Identifier (VID) that uniquely identifies the VLAN to which the Ethernet frame belongs.

With the addition of VLAN tagging, the 802.3ac standard permits the maximum length of an Ethernet frame to be extended from 1518 bytes to 1522 bytes. [Table 36-3](#) illustrates the format of an Ethernet frame that has been “tagged” with a VLAN identifier according to the IEEE 802.3ac standard.

Table 36-3. Ethernet Frame with VLAN Tagging

Preamble	7 bytes
Start Frame Delimiter	1 byte
Dest. MAC Address	6 bytes
Source MAC Address	6 bytes
Length/Type = 802.1Q Tag Type	2 byte
Tag Control Information	2 bytes
Length / Type	2 bytes
MAC Client Data	0 - n bytes
Pad	0 - p bytes
Frame Check Sequence	4 bytes

36.5.4 DMA Operations

Frame data is transferred to and from the Ethernet MAC via the DMA interface. All transfers are 32-bit words and may be single accesses or bursts of two, three or four words. Burst accesses do not cross 16-byte boundaries.

The DMA controller performs four types of operations on the ASB bus. In order of priority, these operations are receive buffer manager read, receive buffer manager write, transmit data DMA read and receive data DMA write.

36.5.4.1 *Transmitter Mode*

Transmit frame data needs to be stored in contiguous memory locations. It does not need to be word-aligned.

The transmit address register is written with the address of the first byte to be transmitted.

Transmit is initiated by writing the number of bytes to transfer (length) to the transmit control register.

The transmit channel then reads data from memory 32 bits at a time and places them in the transmit FIFO.

The transmit block starts frame transmission when three words have been loaded into the FIFO.

The transmit address register must be written before the transmit control register. While a frame is being transmitted, it is possible to set up one other frame for transmission by writing new values to the transmit address and control registers. Reading the transmit address register returns the address of the buffer currently being accessed by the transmit FIFO.

Reading the transmit control register returns the total number of bytes to be transmitted. The BNQ bit in the Transmit Status Register indicates whether another buffer can be safely queued. An interrupt is generated whenever this bit is set.

Frame assembly starts by adding preamble and the start frame delimiter. Data is taken from the transmit FIFO word-by-word. If necessary, padding is added to make the frame length 60 bytes. The CRC is calculated as a 32-bit polynomial. This is inverted and appended to the end of the frame, making the frame length a minimum of 64 bytes. The CRC is not appended if the NCRC bit is set in the transmit control register.

In full-duplex mode, frames are transmitted immediately. Back-to-back frames are transmitted at least 96 bit times apart to guarantee the inter-frame gap.

In half-duplex mode, the transmitter checks carrier sense. If asserted, it waits for it to de-assert and then starts transmission after the inter-frame gap of 96 bit-times.

If the collision signal is asserted during transmission, the transmitter transmits a jam sequence of 32 bits taken from the data register and then retries transmission after the backoff time has elapsed. An error is indicated and any further attempts aborted if 16 attempts cause collisions.

If transmit DMA underruns, bad CRC is automatically appended using the same mechanism as jam insertion. Underrun also causes TXER to be asserted.

36.5.4.2 *Receiver Mode*

When a packet is received, it is checked for valid preamble, CRC, alignment, length and address. If all these criteria are met, the packet is stored successfully in a receive buffer. If at the end of reception the CRC is bad, then the received buffer is recovered. Each received frame including CRC is written to a single receive buffer.

Receive buffers are word-aligned and are capable of containing 1518 or 1522 bytes (BIG = 1 in ETH_CFG) of data (the maximum length of an Ethernet frame).

The start location for each received frame is stored in memory in a list of receive buffer descriptors at a location pointed to by the receive buffer queue pointer register. Each entry in the list

consists of two words. The first word is the address of the received buffer; the second is the receive status. [Table 36-4](#) defines an entry in the received buffer descriptor list.

To receive frames, the buffer queue must be initialized by writing an appropriate address to bits [31:2] in the first word of each list entry. Bit zero of word zero must be written with zero.

After a frame is received, bit zero becomes set and the second word indicates what caused the frame to be copied to memory. The start location of the received buffer descriptor list should be written to the received buffer queue pointer register before receive is enabled (by setting the receive enable bit in the network control register). As soon as the received block starts writing received frame data to the receive FIFO, the received buffer manager reads the first receive buffer location pointed to by the received buffer queue pointer register. If the filter block is active, the frame should be copied to memory; the receive data DMA operation starts writing data into the receive buffer. If an error occurs, the buffer is recovered. If the frame is received without error, the queue entry is updated. The buffer pointer is rewritten to memory with its low-order bit set to indicate successful frame reception and a used buffer. The next word is written with the length of the frame and how the destination address was recognized. The next receive buffer location is then read from the following word or, if the current buffer pointer had its wrap bit set, the beginning of the table. The maximum number of buffer pointers before a wrap bit is seen is 1024. If a wrap bit is not seen by then, a wrap bit is assumed in that entry. The received buffer queue pointer register must be written with zero in its lower-order bit positions to enable the wrap function to work correctly.

If bit zero is set when the receive buffer manager reads the location of the receive buffer, then the buffer has already been used and cannot be used again until software has processed the frame and cleared bit zero. In this case, the DMA block sets the buffer unavailable bit in the received status register and triggers an interrupt. The frame is discarded and the queue entry is reread on reception of the next frame to see if the buffer is now available. Each discarded frame increments a statistics register that is cleared on being read. When there is network congestion, it is possible for the MAC to be programmed to apply back pressure.

This is when half-duplex mode collisions are forced on all received frames by transmitting 64 bits of data (a default pattern).

Reading the received buffer queue register returns the location of the queue entry currently being accessed. The queue wraps around to the start after either 1024 entries (i.e., 2048 words) or when the wrap bit is found to be set in bit 1 of the first word of an entry.

Table 36-4. Received Buffer Descriptor List

Bit	Function
Word 0	
31:2	Base address of receive buffer
1	Wrap bit. If this bit is set, the counter that is ORed with the received buffer queue pointer register to give the pointer to entries in this table is cleared after the buffer is used.
0	Ownership bit. 1 indicates software owns the pointer, 0 indicates that the DMA owns the buffer. If this bit is not zero when the entry is read by the receiver, the buffer unavailable bit is set in the received status register and the receiver goes inactive.
Word 1	
31	Global all ones broadcast address detected

Table 36-4. Received Buffer Descriptor List

Bit	Function
30	Multicast hash match
29	Unicast hash match
28	External address (optional)
27	Unknown source address (reserved for future use)
26	Local address match (Specific address 1 match)
25	Local address match (Specific address 2 match)
24	Local address match (Specific address 3 match)
23	Local address match (Specific address 4 match)
22:11	Reserved; written to 0
10:0	Length of frame including FCS

36.5.5 Address Checking

Whether or not a frame is stored depends on what is enabled in the network configuration register, the contents of the specific address and hash registers and the frame destination address. In this implementation of the MAC the frame source address is not checked.

A frame is not copied to memory if the MAC is transmitting in half-duplex mode at the time a destination address is received.

The hash register is 64 bits long and takes up two locations in the memory map.

There are four 48-bit specific address registers, each taking up two memory locations. The first location contains the first four bytes of the address; the second location contains the last two bytes of the address stored in its least significant byte positions. The addresses stored can be specific, group, local or universal.

Ethernet frames are transmitted a byte at a time, LSB first. The first bit (i.e., the LSB of the first byte) of the destination address is the group/individual bit and is set one for multicast addresses and zero for unicast. This bit corresponds to bit 24 of the first word of the specific address register. The MSB of the first byte of the destination address corresponds to bit 31 of the specific address register.

The specific address registers are compared to the destination address of received frames once they have been activated. Addresses are deactivated at reset or when the first byte [47:40] is written and activated or when the last byte [7:0] is written. If a receive frame address matches an active address, the local match signal is set and the store frame pulse signal is sent to the DMA block via the HCLK synchronization block.

A frame can also be copied if a unicast or multicast hash match occurs, it has the broadcast address of all ones, or the copy all frames bit in the network configuration register is set.

The broadcast address of 0xFFFFFFFF is recognized if the no broadcast bit in the network configuration register is zero. This sets the broadcast match signal and triggers the store frame signal.

The unicast hash enable and the multicast hash enable bits in the network configuration register enable the reception of hash matched frames. So all multicast frames can be received by setting all bits in the hash register.

The CRC algorithm reduces the destination address to a 6-bit index into a 64-bit hash register. If the equivalent bit in the register is set, the frame is matched depending on whether the frame is multicast or unicast and the appropriate match signals are sent to the DMA block. If the copy all frames bit is set in the network configuration register, the store frame pulse is always sent to the DMA block as soon as any destination address is received.

36.6 Ethernet MAC (EMAC) User Interface

Table 36-5. EMAC Register Mapping

Offset	Register	Register Name	Read/Write	Reset
0x00	EMAC Control Register	ETH_CTL	Read/Write	0x0
0x04	EMAC Configuration Register	ETH_CFG	Read/Write	0x800
0x08	EMAC Status Register	ETH_SR	Read-only	0x6
0x0C	EMAC Transmit Address Register	ETH_TAR	Read/Write	0x0
0x10	EMAC Transmit Control Register	ETH_TCR	Read/Write	0x0
0x14	EMAC Transmit Status Register	ETH_TSR	Read/Write	0x18
0x18	EMAC Receive Buffer Queue Pointer	ETH_RBQP	Read/Write	0x0
0x1C	Reserved	–	Read-only	0x0
0x20	EMAC Receive Status Register	ETH_RSR	Read/Write	0x0
0x24	EMAC Interrupt Status Register	ETH_ISR	Read/Write	0x0
0x28	EMAC Interrupt Enable Register	ETH_IER	Write-only	–
0x2C	EMAC Interrupt Disable Register	ETH_IDR	Write-only	–
0x30	EMAC Interrupt Mask Register	ETH_IMR	Read-only	0xFFFF
0x34	EMAC PHY Maintenance Register	ETH_MAN	Read/Write	0x0
Statistics Registers⁽¹⁾				
0x40	Frames Transmitted OK Register	ETH_FRA	Read/Write	0x0
0x44	Single Collision Frame Register	ETH_SCOL	Read/Write	0x0
0x48	Multiple Collision Frame Register	ETH_MCOL	Read/Write	0x0
0x4C	Frames Received OK Register	ETH_OK	Read/Write	0x0
0x50	Frame Check Sequence Error Register	ETH_SEQE	Read/Write	0x0
0x54	Alignment Error Register	ETH_ALE	Read/Write	0x0
0x58	Deferred Transmission Frame Register	ETH_DTE	Read/Write	0x0
0x5C	Late Collision Register	ETH_LCOL	Read/Write	0x0
0x60	Excessive Collision Register	ETH_ECOL	Read/Write	0x0
0x64	Transmit Underrun Error Register	ETH_TUE	Read/Write	0x0
0x68	Carrier Sense Error Register	ETH_CSE	Read/Write	0x0
0x6C	Discard RX Frame Register	ETH_DRFC	Read/Write	0x0
0x70	Receive Overrun Register	ETH_ROV	Read/Write	0x0
0x74	Code Error Register	ETH_CDE	Read/Write	0x0
0x78	Excessive Length Error Register	ETH_ELRL	Read/Write	0x0
0x7C	Receive Jabber Register	ETH_RJB	Read/Write	0x0
0x80	Undersize Frame Register	ETH_USF	Read/Write	0x0
0x84	SQE Test Error Register	ETH_SQEE	Read/Write	0x0

Table 36-5. EMAC Register Mapping (Continued)

Offset	Register	Register Name	Read/Write	Reset
Address Registers				
0x90	EMAC Hash Address Low [31:0]	ETH_HSL	Read/Write	0x0
0x94	EMAC Hash Address High [63:32]	ETH_HSH	Read/Write	0x0
0x98	EMAC Specific Address 1 Low, First 4 Bytes	ETH_SA1L	Read/Write	0x0
0x9C	EMAC Specific Address 1 High, Last 2 Bytes	ETH_SA1H	Read/Write	0x0
0xA0	EMAC Specific Address 2 Low, First 4 Bytes	ETH_SA2L	Read/Write	0x0
0xA4	EMAC Specific Address 2 High, Last 2 Bytes	ETH_SA2H	Read/Write	0x0
0xA8	EMAC Specific Address 3 Low, First 4 Bytes	ETH_SA3L	Read/Write	0x0
0xAC	EMAC Specific Address 3 High, Last 2 Bytes	ETH_SA3H	Read/Write	0x0
0xB0	EMAC Specific Address 4 Low, First 4 Bytes	ETH_SA4L	Read/Write	0x0
0xB4	EMAC Specific Address 4 High, Last 2 Bytes	ETH_SA4H	Read/Write	0x0

Note: 1. For further details on the statistics registers, see [Table 36-6 on page 629](#).

36.6.1 EMAC Control Register

Name: ETH_CTL

Access Type: Read/Write

31	30	29	28	27	26	25	24
–	–	–	–	–	–	–	–
23	22	21	20	19	18	17	16
–	–	–	–	–	–	–	–
15	14	13	12	11	10	9	8
–	–	–	–	–	–	–	BP
7	6	5	4	3	2	1	0
WES	ISR	CSR	MPE	TE	RE	LBL	LB

- **LB: Loopback**

Optional. When set, loopback signal is at high level.

- **LBL: Loopback Local**

When set, connects ETX[3:0] to ERX[3:0], ETXEN to ERXDV, forces full duplex and drives ERXCK and ETXCK_REFCK with MCK divided by 4.

- **RE: Receive Enable**

When set, enables the Ethernet MAC to receive data.

- **TE: Transmit Enable**

When set, enables the Ethernet transmitter to send data.

- **MPE: Management Port Enable**

Set to one to enable the management port. When zero, forces MDIO to high impedance state.

- **CSR: Clear Statistics Registers**

This bit is write-only. Writing a one clears the statistics registers.

- **ISR: Increment Statistics Registers**

This bit is write-only. Writing a one increments all the statistics registers by one for test purposes.

- **WES: Write Enable for Statistics Registers**

Setting this bit to one makes the statistics registers writable for functional test purposes.

- **BP: Back Pressure**

If this field is set, then in half-duplex mode collisions are forced on all received frames by transmitting 64 bits of data (default pattern).

36.6.2 EMAC Configuration Register

Name: ETH_CFG

Access Type: Read/Write

31	30	29	28	27	26	25	24
–	–	–	–	–	–	–	–
23	22	21	20	19	18	17	16
–	–	–	–	–	–	–	–
15	14	13	12	11	10	9	8
–	–	RMII	RTY	CLK		EAE	BIG
7	6	5	4	3	2	1	0
UNI	MTI	NBC	CAF	–	BR	FD	SPD

- **SPD: Speed**

Set to 1 to indicate 100 Mbit/sec, 0 for 10 Mbit/sec. Has no other functional effect.

- **FD: Full Duplex**

If set to 1, the transmit block ignores the state of collision and carrier sense and allows receive while transmitting.

- **BR: Bit Rate**

Optional.

- **CAF: Copy All Frames**

When set to 1, all valid frames are received.

- **NBC: No Broadcast**

When set to 1, frames addressed to the broadcast address of all ones are not received.

- **MTI: Multicast Hash Enable**

When set multicast frames are received when six bits of the CRC of the destination address point to a bit that is set in the hash register.

- **UNI: Unicast Hash Enable**

When set, unicast frames are received when six bits of the CRC of the destination address point to a bit that is set in the hash register.

- **BIG: Receive 1522 Bytes**

When set, the MAC receives up to 1522 bytes. Normally the MAC receives frames up to 1518 bytes in length.

This bit allows to receive extended Ethernet frame with “VLAN tag” (IEEE 802.3ac)

- **EAE: External Address Match Enable**

Optional.

- **CLK**

The system clock (MCK) is divided down to generate MDC (the clock for the MDIO). To conform with IEEE standard 802.3 MDC must not exceed 2.5 MHz. At reset this field is set to 10 so that MCK is divided by 32.

CLK	MDC
00	MCK divided by 8
01	MCK divided by 16
10	MCK divided by 32
11	MCK divided by 64

- **RTY: Retry Test**

When set, the time between frames is always one time slot. For test purposes only. Must be cleared for normal operation.

- **RMII: Reduce MII**

When set, this bit enables the RMII operation mode. When reset, it selects the MII mode.

36.6.3 EMAC Status Register

Name: ETH_SR

Access Type: Read only

31	30	29	28	27	26	25	24
–	–	–	–	–	–	–	–
23	22	21	20	19	18	17	16
–	–	–	–	–	–	–	–
15	14	13	12	11	10	9	8
–	–	–	–	–	–	–	–
7	6	5	4	3	2	1	0
–	–	–	–	–	IDLE	MDIO	LINK

- **LINK**

Reserved.

- **MDIO**

0 = MDIO pin not set.

1 = MDIO pin set.

- **IDLE**

0 = PHY logic is idle.

1 = PHY logic is running.

36.6.4 EMAC Transmit Address Register

Name: ETH_TAR

Access Type: Read/Write

31	30	29	28	27	26	25	24
ADDRESS							
23	22	21	20	19	18	17	16
ADDRESS							
15	14	13	12	11	10	9	8
ADDRESS							
7	6	5	4	3	2	1	0
ADDRESS							

- **ADDRESS: Transmit Address Register**

Written with the address of the frame to be transmitted, read as the base address of the buffer being accessed by the transmit FIFO. Note that if the two least significant bits are not zero, transmit starts at the byte indicated.

36.6.5 EMAC Transmit Control Register

Name: ETH_TCR

Access Type: Read/Write

31	30	29	28	27	26	25	24
–	–	–	–	–	–	–	–
23	22	21	20	19	18	17	16
–	–	–	–	–	–	–	–
15	14	13	12	11	10	9	8
NCRC	–	–	–	–	LEN		
7	6	5	4	3	2	1	0
LEN							

- **LEN: Transmit Frame Length**

This register is written to the number of bytes to be transmitted excluding the four CRC bytes unless the no CRC bit is asserted. Writing these bits to any non-zero value initiates a transmission. If the value is greater than 1514 (1518 if no CRC is being generated), an oversize frame is transmitted. This field is buffered so that a new frame can be queued while the previous frame is still being transmitted. Must always be written in address-then-length order. Reads as the total number of bytes to be transmitted (i.e., this value does not change as the frame is transmitted.) Frame transmission does not start until two 32-bit words have been loaded into the transmit FIFO. The length must be great enough to ensure two words are loaded.

- **NCRC: No CRC**

If this bit is set, it is assumed that the CRC is included in the length being written in the low-order bits and the MAC does not append CRC to the transmitted frame. If the buffer is not at least 64 bytes long, a short frame is sent. This field is buffered so that a new frame can be queued while the previous frame is still being transmitted. Reads as the value of the frame currently being transmitted.

36.6.6 EMAC Transmit Status Register

Name: ETH_TSR

Access Type: Read/Write

31	30	29	28	27	26	25	24
–	–	–	–	–	–	–	–
23	22	21	20	19	18	17	16
–	–	–	–	–	–	–	–
15	14	13	12	11	10	9	8
–	–	–	–	–	–	–	–
7	6	5	4	3	2	1	0
–	UND	COMP	BNQ	IDLE	RLE	COL	OVR

- **OVR: Ethernet Transmit Buffer Overrun**

Software has written to the Transmit Address Register (ETH_TAR) or Transmit Control Register (ETH_TCR) when bit BNQ was not set. Cleared by writing a one to this bit.

- **COL: Collision Occurred**

Set by the assertion of collision. Cleared by writing a one to this bit.

- **RLE: Retry Limit Exceeded**

Cleared by writing a one to this bit.

- **IDLE: Transmitter Idle**

Asserted when the transmitter has no frame to transmit. Cleared when a length is written to transmit frame length portion of the Transmit Control register. This bit is read-only.

- **BNQ: Ethernet Transmit Buffer not Queued**

Software may write a new buffer address and length to the transmit DMA controller when set. Cleared by having one frame ready to transmit and another in the process of being transmitted. This bit is read-only.

- **COMP: Transmit Complete**

Set when a frame has been transmitted. Cleared by writing a one to this bit.

- **UND: Transmit Underrun**

Set when transmit DMA was not able to read data from memory in time. If this happens, the transmitter forces bad CRC. Cleared by writing a one to this bit.

36.6.7 EMAC Receive Buffer Queue Pointer Register

Name: ETH_RBQP

Access Type: Read/Write

31	30	29	28	27	26	25	24
ADDRESS							
23	22	21	20	19	18	17	16
ADDRESS							
15	14	13	12	11	10	9	8
ADDRESS							
7	6	5	4	3	2	1	0
ADDRESS							

- **ADDRESS: Receive Buffer Queue Pointer**

Written with the address of the start of the receive queue, reads as a pointer to the current buffer being used. The receive buffer is forced to word alignment.

36.6.8 EMAC Receive Status Register

Name: ETH_RSR

Access Type: Read/Write

31	30	29	28	27	26	25	24
–	–	–	–	–	–	–	–
23	22	21	20	19	18	17	16
–	–	–	–	–	–	–	–
15	14	13	12	11	10	9	8
–	–	–	–	–	–	–	–
7	6	5	4	3	2	1	0
–	–	–	–	–	OVR	REC	BNA

- **BNA: Buffer Not Available**

An attempt was made to get a new buffer and the pointer indicated that it was owned by the processor. The DMA rereads the pointer each time a new frame starts until a valid pointer is found. This bit is set at each attempt that fails even if it has not had a successful pointer read since it has been cleared. Cleared by writing a one to this bit.

- **REC: Frame Received**

One or more frames have been received and placed in memory. Cleared by writing a one to this bit.

- **OVR: RX Overrun**

The DMA block was unable to store the receive frame to memory, either because the ASB bus was not granted in time or because a not OK HRESP was returned. The buffer is recovered if this happens. Cleared by writing a one to this bit.

36.6.9 EMAC Interrupt Status Register

Name: ETH_ISR

Access Type: Read/Write

31	30	29	28	27	26	25	24
–	–	–	–	–	–	–	–
23	22	21	20	19	18	17	16
–	–	–	–	–	–	–	–
15	14	13	12	11	10	9	8
–	–	–	–	ABT	ROVR	LINK	TIDLE
7	6	5	4	3	2	1	0
TCOM	TBRE	RTRY	TUND	TOVR	RBNA	RCOM	DONE

- **DONE: Management Done**

The PHY maintenance register has completed its operation. Cleared on read.

- **RCOM: Receive Complete**

A frame has been stored in memory. Cleared on read.

- **RBNA: Receive Buffer Not Available**

Cleared on read.

- **TOVR: Transmit Buffer Overrun**

Software has written to the Transmit Address Register (ETH_TAR) or Transmit Control Register (ETH_TCR) when BNQ of the Transmit Status Register (ETH_TSR) was not set. Cleared on read.

- **TUND: Transmit Buffer Underrun**

Ethernet transmit buffer underrun. The transmit DMA did not complete fetch frame data in time for it to be transmitted. Cleared on read.

- **RTRY: Retry Limit**

Retry limit exceeded. Cleared on read.

- **TBRE: Transmit Buffer Register Empty**

Software may write a new buffer address and length to the transmit DMA controller. Cleared by having one frame ready to transmit and another in the process of being transmitted. Cleared on read.

- **TCOM: Transmit Complete**

Set when a frame has been transmitted. Cleared on read.

- **TIDLE: Transmit Idle**

Set when all frames have been transmitted. Cleared on read.

- **LINK**



Set when LINK pin changes value. Optional.

- **ROVR: RX Overrun**

Set when the RX overrun status bit is set. Cleared on read.

- **ABT: Abort**

Set when an abort occurs during a DMA transfer. Cleared on read.

36.6.10 EMAC Interrupt Enable Register

Name: ETH_IER

Access Type: Write only

31	30	29	28	27	26	25	24
–	–	–	–	–	–	–	–
23	22	21	20	19	18	17	16
–	–	–	–	–	–	–	–
15	14	13	12	11	10	9	8
–	–	–	–	ABT	ROVR	LINK	TIDLE
7	6	5	4	3	2	1	0
TCOM	TBRE	RTRY	TUND	TOVR	RBNA	RCOM	DONE

- **DONE: Management Done Interrupt Enable**
- **RCOM: Receive Complete Interrupt Enable**
- **RBNA: Receive Buffer Not Available Interrupt Enable**
- **TOVR: Transmit Buffer Overrun Interrupt Enable**
- **TUND: Transmit Buffer Underrun Interrupt Enable**
- **RTRY: Retry Limit Interrupt Enable**
- **TBRE: Transmit Buffer Register Empty Interrupt Enable**
- **TCOM: Transmit Complete Interrupt Enable**
- **TIDLE: Transmit Idle Interrupt Enable**
- **LINK: LINK Interrupt Enable**
- **ROVR: RX Overrun Interrupt Enable**
- **ABT: Abort Interrupt Enable**

0: No effect.

1: Enables the corresponding interrupt.

36.6.11 EMAC Interrupt Disable Register

Name: ETH_IDR

Access Type: Write only

31	30	29	28	27	26	25	24
–	–	–	–	–	–	–	–
23	22	21	20	19	18	17	16
–	–	–	–	–	–	–	–
15	14	13	12	11	10	9	8
–	–	–	–	ABT	ROVR	LINK	TIDLE
7	6	5	4	3	2	1	0
TCOM	TBRE	RTRY	TUND	TOVR	RBNA	RCOM	DONE

- **DONE: Management Done Interrupt Disable**
- **RCOM: Receive Complete Interrupt Disable**
- **RBNA: Receive Buffer Not Available Interrupt Disable**
- **TOVR: Transmit Buffer Overrun Interrupt Disable**
- **TUND: Transmit Buffer Underrun Interrupt Disable**
- **RTRY: Retry Limit Interrupt Disable**
- **TBRE: Transmit Buffer Register Empty Interrupt Disable**
- **TCOM: Transmit Complete Interrupt Disable**
- **TIDLE: Transmit Idle Interrupt Disable**
- **LINK: LINK Interrupt Disable**
- **ROVR: RX Overrun Interrupt Disable**
- **ABT: Abort Interrupt Disable**

0: No effect.

1: Disables the corresponding interrupt.

36.6.12 EMAC Interrupt Mask Register

Name: ETH_IMR

Access Type: Read only

31	30	29	28	27	26	25	24
–	–	–	–	–	–	–	–
23	22	21	20	19	18	17	16
–	–	–	–	–	–	–	–
15	14	13	12	11	10	9	8
–	–	–	–	ABT	ROVR	LINK	TIDLE
7	6	5	4	3	2	1	0
TCOM	TBRE	RTRY	TUND	TOVR	RBNA	RCOM	DONE

- **DONE: Management Done Interrupt Mask**
- **RCOM: Receive Complete Interrupt Mask**
- **RBNA: Receive Buffer Not Available Interrupt Mask**
- **TOVR: Transmit Buffer Overrun Interrupt Mask**
- **TUND: Transmit Buffer Underrun Interrupt Mask**
- **RTRY: Retry Limit Interrupt Mask**
- **TBRE: Transmit Buffer Register Empty Interrupt Mask**
- **TCOM: Transmit Complete Interrupt Mask**
- **TIDLE: Transmit Idle Interrupt Mask**
- **LINK: LINK Interrupt Mask**
- **ROVR: RX Overrun Interrupt Mask**
- **ABT: Abort Interrupt Mask**

0: The corresponding interrupt is enabled.

1: The corresponding interrupt is not enabled.

Important Note: The interrupt is disabled when the corresponding bit is set. This is non-standard for AT91 products as generally a mask bit set enables the interrupt.

36.6.13 EMAC PHY Maintenance Register

Name: ETH_MAN

Access Type: Read/Write

31	30	29	28	27	26	25	24
LOW	HIGH	RW		PHYA			
23	22	21	20	19	18	17	16
PHYA	REGA					CODE	
15	14	13	12	11	10	9	8
DATA							
7	6	5	4	3	2	1	0
DATA							

Writing to this register starts the shift register that controls the serial connection to the PHY. On each shift cycle the MDIO pin becomes equal to the MSB of the shift register and LSB of the shift register becomes equal to the value of the MDIO pin. When the shifting is complete an interrupt is generated and the IDLE field is set in the Network Status register.

When read, gives current shifted value.

- **DATA**

For a write operation this is written with the data to be written to the PHY. After a read operation this contains the data read from the PHY.

- **CODE**

Must be written to 10 in accordance with IEEE standard 802.3. Reads as written.

- **REGA**

Register address. Specifies the register in the PHY to access.

- **PHYA**

PHY address. Normally is 0.

- **RW**

Read/Write Operation. 10 is read. 01 is write. Any other value is an invalid PHY management frame.

- **HIGH**

Must be written with 1 to make a valid PHY management frame. Conforms with IEEE standard 802.3.

- **LOW**

Must be written with 0 to make a valid PHY management frame. Conforms with IEEE standard 802.3.

36.6.14 EMAC Hash Address Low Register

Name: ETH_HSL

Access Type: Read/Write

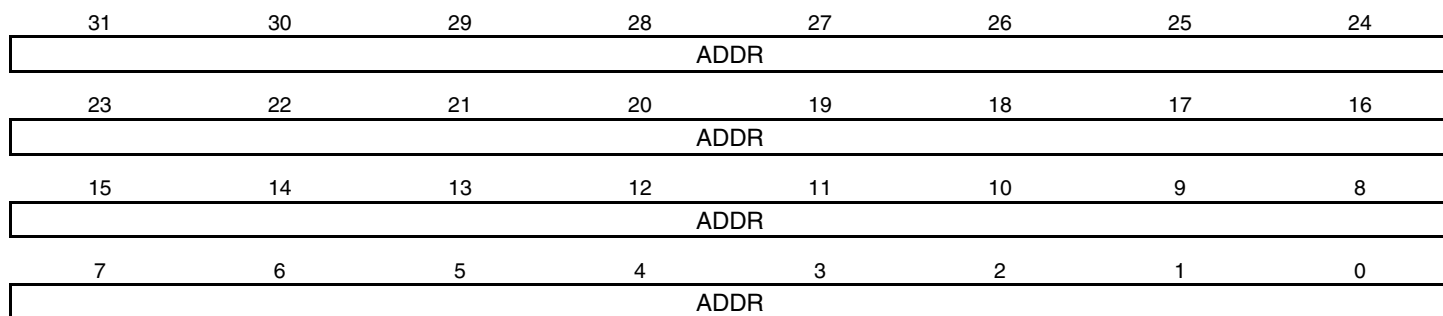

- **ADDR**

Hash address bits 31 to 0.

36.6.15 EMAC Hash Address High Register

Name: ETH_HSH

Access Type: Read/Write

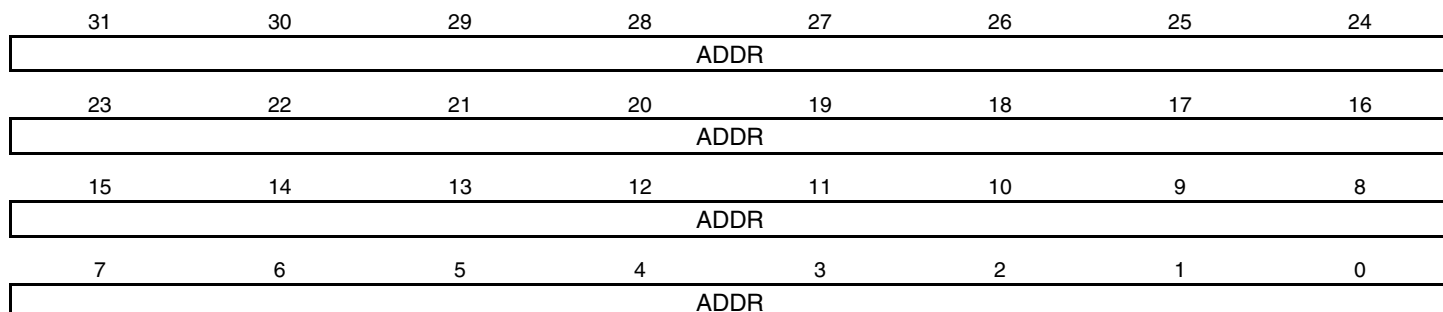

- **ADDR**

Hash address bits 63 to 32.

36.6.16 EMAC Specific Address (1, 2, 3 and 4) High Register

Name: ETH_SA1H,...ETH_SA4H

Access Type: Read/Write

31	30	29	28	27	26	25	24
–	–	–	–	–	–	–	–
23	22	21	20	19	18	17	16
–	–	–	–	–	–	–	–
15	14	13	12	11	10	9	8
ADDR							
7	6	5	4	3	2	1	0
ADDR							

- ADDR

Unicast addresses (1, 2, 3 and 4), Bits 47:32.

36.6.17 EMAC Specific Address (1, 2, 3 and 4) Low Register

Name: ETH_SA1L,...ETH_SA4L

Access Type: Read/Write

31	30	29	28	27	26	25	24
ADDR							
23	22	21	20	19	18	17	16
ADDR							
15	14	13	12	11	10	9	8
ADDR							
7	6	5	4	3	2	1	0
ADDR							

- ADDR

Unicast addresses (1, 2, 3 and 4), Bits 31:0.

36.6.18 EMAC Statistics Register Block Registers

These registers reset to zero on a read and remain at all ones when they count to their maximum value. They should be read frequently enough to prevent loss of data.

The statistics register block contains the registers found in [Table 36-6](#).

Table 36-6. EMAC Statistic Register Block Register Descriptions

Register	Register Name	Description
Frames Transmitted OK Register	ETH_FRA	A 24-bit register counting the number of frames successfully transmitted.
Single Collision Frame Register	ETH_SCOL	A 16-bit register counting the number of frames experiencing a single collision before being transmitted and experiencing no carrier loss nor underrun.
Multiple Collision Frame Register	ETH_MCOL	A 16-bit register counting the number of frames experiencing between two and fifteen collisions prior to being transmitted (62 - 1518 bytes, no carrier loss, no underrun).
Frames Received OK Register	ETH_OK	A 24-bit register counting the number of good frames received, i.e., address recognized. A good frame is of length 64 to 1518 bytes and has no FCS, alignment or code errors.
Frame Check Sequence Error Register	ETH_SEQE	An 8-bit register counting address-recognized frames that are an integral number of bytes long, that have bad CRC and that are 64 to 1518 bytes long.
Alignment Error Register	ETH_ALE	An 8-bit register counting frames that: <ul style="list-style-type: none"> - are address-recognized, - are not an integral number of bytes long, - have bad CRC when their length is truncated to an integral number of bytes, - are between 64 and 1518 bytes long.
Deferred Transmission Frame Register	ETH_DTE	A 16-bit register counting the number of frames experiencing deferral due to carrier sense active on their first attempt at transmission (no underrun or collision).
Late Collision Register	ETH_LCOL	An 8-bit register counting the number of frames that experience a collision after the slot time (512 bits) has expired. No carrier loss or underrun. A late collision is counted twice, i.e., both as a collision and a late collision.
Excessive Collision Register	ETH_ECOL	An 8-bit register counting the number of frames that failed to be transmitted because they experienced 16 collisions (64 - 1518 bytes, no carrier loss or underrun).
Transmit Underrun Error Register	ETH_TUE	An 8-bit register counting the number of frames not transmitted due to a transmit DMA underrun. If this register is incremented, then no other register is incremented.
Carrier Sense Error Register	ETH_CSE	An 8-bit register counting the number of frames for which carrier sense was not detected and that were maintained in half-duplex mode one slot time (512 bits) after the start of transmission (no excessive collision).
Discard RX Frame Register	ETH_DRFC	This 16-bit counter is incremented every time an address-recognized frame is received but cannot be copied to memory because no receive buffer is available.
Receive Overrun Register	ETH_ROV	An 8-bit register counting the number of frames that are address-recognized but were not copied to memory due to a receive DMA overrun.
Code Error Register	ETH_CDE	An 8-bit register counting the number of frames that are address-recognized, had RXER asserted during reception. If this counter is incremented, then no other counters are incremented.

Table 36-6. EMAC Statistic Register Block Register Descriptions (Continued)

Register	Register Name	Description
Excessive Length Error Register	ETH_ELR	An 8-bit register counting the number of frames received exceeding 1518 bytes in length but that do not have either a CRC error, an alignment error or a code error.
Receive Jabber Register	ETH_RJB	An 8-bit register counting the number of frames received exceeding 1518 bytes in length and having either a CRC error, an alignment error or a code error.
Undersize Frame Register	ETH_USF	An 8-bit register counting the number of frames received less than 64 bytes in length but that do not have either a CRC error, an alignment error or a code error.
SQE Test Error Register	ETH_SQEE	An 8-bit register counting the number of frames where pin ECOL was not asserted within a slot time of pin ETXEN being deasserted.

37. AT91RM9200 Electrical Characteristics

37.1 Absolute Maximum Ratings

Table 37-1. Absolute Maximum Ratings*

Operating Temperature (Industrial)	-40 C to +85 C
Storage Temperature	-60°C to +150°C
Voltage on Input Pins with Respect to Ground	-0.3V to VDDIO+0.3V (+4V max)
Maximum Operating Voltage (V _{DDCORE} , V _{DDPLL} and V _{DDOSC})	2V
Maximum Operating Voltage (V _{DDIOM} and V _{DDIOP})	4V
DC Output Current (SDA10, SDCKE, SDWE, RAS, CAS)	16 mA
DC Output Current (Any other pin)	8 mA

*NOTICE: Stresses beyond those listed under “Absolute Maximum Ratings” may cause permanent damage to the device. This is a stress rating only and functional operation of the device at these or other conditions beyond those indicated in the operational sections of this specification is not implied. Exposure to absolute maximum rating conditions for extended periods may affect device reliability.

37.2 DC Characteristics

The following characteristics are applicable to the operating temperature range: $T_A = -40^{\circ}\text{C}$ to 85°C , unless otherwise specified and are certified for a junction temperature up to $T_J = 100^{\circ}\text{C}$.

Table 37-2. DC Characteristics

Symbol	Parameter	Conditions	Min	Typ	Max	Units
V_{DDCORE}	DC Supply Core		1.65		1.95	V
V_{DDOSC}	DC Supply Oscillator		1.65		1.95	V
V_{DDPLL}	DC Supply PLL		1.65		1.95	V
V_{DDIOM}	DC Supply Memory I/Os		3.0		3.6	V
V_{DDIOP}	DC Supply Peripheral I/Os		3.0		3.6	V
V_{IL}	Input Low-level Voltage		-0.3		0.8	V
V_{IH}	Input High-level Voltage		2		$V_{DD} + 0.3^{(1)}$	V
V_{OL}	Output Low-level Voltage	SDA10, SDCKE, SDWE, RAS, CAS pins: $I_{OL} = 16\text{ mA}^{(2)}$ $I_{OL} = 0\text{ mA}^{(2)}$			0.4 0.2	V
		Other pins: $I_{OL} = 8\text{ mA}^{(2)}$ $I_{OL} = 0\text{ mA}^{(2)}$			0.4 0.2	
V_{OH}	Output High-level Voltage	SDA10, SDCKE, SDWE, RAS, CAS pins: $I_{OH} = 16\text{ mA}^{(2)}$ $I_{OH} = 0\text{ mA}^{(2)}$	$V_{DD} - 0.4^{(1)}$ $V_{DD} - 0.2^{(1)}$			V
		Other pins: $I_{OH} = 8\text{ mA}^{(2)}$ $I_{OH} = 0\text{ mA}^{(2)}$	$V_{DD} - 0.4^{(1)}$ $V_{DD} - 0.2^{(1)}$			
I_{LEAK}	Input Leakage Current	Pullup resistors disabled			1	μA
I_{PULL}	Input Pull-up Current	$V_{DD} = 3.0\text{V}^{(1)}$, $V_{IN} = 0$	8			μA
		$V_{DD} = 3.6\text{V}^{(1)}$, $V_{IN} = 0$			30	
R_{PULLUP}	Internal Pull-up Value			200		kOhm
C_{IN}	Input Capacitance	208-PQFP Package			8.8	pF
		256-LFBGA Package			7.6	
I_{SC}	Static Current	On $V_{DDCORE} = 2\text{V}$, MCK = 0 Hz All inputs driven TMS, TDI, TCK, NRST = 1	$T_A = 25^{\circ}\text{C}$	350	2000	μA
			$T_A = 85^{\circ}\text{C}$	2800	14000	

- Notes: 1. V_{DD} is applicable to V_{DDIOM} , V_{DDIOP} , V_{DDPLL} and V_{DDOSC}
2. I_O = Output Current.

37.3 Clock Characteristics

These parameters are given in the following conditions:

- $V_{DDCORE} = 1.8V$
- Ambient Temperature = 25°C

The Temperature Derating Factor described in the section [38.1.2 “Temperature Derating Factor” on page 640](#) and V_{DDCORE} Voltage Derating Factor described in the section [38.1.3 “VDDCORE Voltage Derating Factor” on page 640](#) are both applicable to these characteristics.

37.3.1 Processor Clock Characteristics

Table 37-3. Processor Clock Waveform Parameters

Symbol	Parameter	Conditions	Min	Max	Units
$1/(t_{CPPCK})$	Processor Clock Frequency			209.0	MHz
t_{CPPCK}	Processor Clock Period		4.8		ns
t_{CHPCK}	Processor Clock High Half-period		2.2		ns
t_{CLPCK}	Processor Clock Low Half-period		2.2		ns

37.3.2 Master Clock Characteristics

Table 37-4. Master Clock Waveform Parameters

Symbol	Parameter	Conditions	Min	Max	Units
$1/(t_{CPMCK})$	Master Clock Frequency			80.0	MHz
t_{CPMCK}	Master Clock Period		12.5		ns
t_{CHMCK}	Master Clock High Half-period		6.3		ns
t_{CLMCK}	Master Clock Low Half-period		6.3		ns

37.4 Crystal Oscillator Characteristics

37.4.1 32 kHz Oscillator Characteristics

Table 37-5. 32 kHz Oscillator Characteristics

Symbol	Parameter	Conditions	Min	Typ	Max	Unit
$1/(t_{CP32KHz})$	Crystal Oscillator Frequency			32.768		kHz
	Duty Cycle	Measured at the PCK output pin	40	50	60	%
t_{ST}	Startup Time	$V_{DDOSC} = 1.8V$ $R_s = 50\ k\Omega, C_L = 12.5\ pF^{(1)}$			900	ms

Note: 1. R_s is the equivalent series resistance, C_L is the equivalent load capacitance

37.4.2 Main Oscillator Characteristics

Table 37-6. Main Oscillator Characteristics

Symbol	Parameter	Conditions	Min	Typ	Max	Unit
$1/(t_{CPMAIN})$	Crystal Oscillator Frequency		3	16	20	MHz
C_{L1}, C_{L2}	Internal Load Capacitance (CL1 = CL2)	Integrated load capacitance (XIN, GND) and (XOUT GND) in series	17	20	23	pF
C_L	Equivalent Load Capacitance	Max external capacitors: 10 pF	20		25	pF
	Duty Cycle	Measured at the PCK output pin	30	50	70	%
t_{ST}	Startup Time	@ 3 MHz $C_{SHUNT} = 3$ pF @ 8 MHz $C_{SHUNT} = 7$ pF @ 16 MHz $C_{SHUNT} = 7$ pF @ 20 MHz $C_{SHUNT} = 7$ pF			14.5 4 1.4 1	ms
P_{ON}	Drive Level	@ 3 MHz @ 8 MHz @ 16 MHz @ 20 MHz			15 30 50 50	μ W
ESR	Equivalent Series Resistor R_s	Fundamental @ 3 MHz Fundamental @ 8 MHz Fundamental @ 16 MHz Fundamental @ 20 MHz			200 100 80 50	Ω
C_M	Motional capacitance				8	fF
C_{SHUNT}	Shunt capacitance				7	pF

37.4.3 XIN Clock Characteristics ⁽¹⁾

Table 37-7. XIN Clock Electrical Characteristics

Symbol	Parameter	Conditions	Min	Max	Units
$1/(t_{CPXIN})$	XIN Clock Frequency			50.0	MHz
t_{CPXIN}	XIN Clock Period		20.0		ns
t_{CHXIN}	XIN Clock High Half-period		$0.4 \times t_{CPXIN}$	$0.6 \times t_{CPXIN}$	
t_{CLXIN}	XIN Clock Low Half-period		$0.4 \times t_{CPXIN}$	$0.6 \times t_{CPXIN}$	
C_{IN}	XIN Input Capacitance	Note (1)		40	pF
R_{IN}	XIN Pulldown Resistor	Note (1)		500	kOhm

Notes: 1. These characteristics apply only when the Main Oscillator is in bypass mode (i.e., when MOSCEN = 0 in the CKGR_MOR register. (See Section 23.6.7 "PMC Clock Generator Main Oscillator Register" on page 283.)

37.5 Power Consumption

The values in Table 37-8 and Table 37-9 are measured values on the AT91RM9200DK Evaluation Board with operating conditions as follows:

- $V_{DDIO} = 3.3V$
- $V_{DDCORE} = V_{DDPLL} = V_{DDOSC} = 1.8V$
- $T_A = 25^\circ C$
- MCK = 60 MHz

- PCK = 180 Mhz
- SLCK = 32.768 kHz
- EMACK 50 MHz clock not connected

These figures represent the power consumption measured on the V_{DDCORE} power supply.

Table 37-8. Power Consumption for PMC Modes⁽¹⁾

Mode	Conditions	Consumption	Unit
Normal	ARM Core clock enabled. All peripheral clocks deactivated.	24.4	mA
Idle	ARM Core clock disabled and waiting for the next interrupt. All peripheral clocks deactivated.	13.8	
Slow Clock	Main oscillator and PLLs are switched off. Processor and all peripherals run at slow clock.	1.44	
Standby	ARM Core clock disabled and waiting for the next interrupt. All peripheral clocks deactivated. Main oscillator and PLLs are switched off. Slow clock still enabled.	520	μ A

Note: 1. Code in internal SRAM.

Table 37-9. Power Consumption by Peripheral⁽¹⁾

Peripheral	Consumption	Unit
PIO Controller	0.5	mA
USART	1.3	
MCI	1.6	
UDP	1.2	
TWI	0.3	
SPI	1.2	
SSC	1.5	
Timer Counter Channel	0.4	
UHP	2.5	
EMAC ⁽²⁾	3.5	
PMC		μ A
PLL ⁽³⁾	3144	nA
Slow Clock Oscillator ⁽³⁾	858	nA
Main Oscillator ⁽⁴⁾	350	μ A

- Notes:
1. Code in internal SRAM.
 2. Master Clock related power consumption only.
 3. Power consumption on the V_{DDPLL} power supply.
 4. Power consumption on the V_{DDOSC} power supply.

37.6 PLL Characteristics

Table 37-10. Phase Lock Loop Characteristics

Symbol	Parameter	Conditions	Min	Typ	Max	Unit
F _{OUT}	Output Frequency	Field OUTA of CKGR_PLLA	00	80	160	MHz
			10	150	180	MHz
		Field OUTB of CKGR_PLLB	00	80	160	MHz
			10	150	180	MHz
F _{IN}	Input Frequency		1	32	MHz	

37.7 Transceiver Characteristics

37.7.1 Electrical Characteristics

Table 37-11. Electrical Parameters

Symbol	Parameter	Conditions	Min	Typ	Max	Unit
Input Levels						
V _{IL}	Low Level				0.8	V
V _{IH}	High Level		2.0			V
V _{DI}	Differential Input Sensitivity	$(D+) - (D-)$	0.2			V
V _{CM}	Differential Input Common Mode Range		0.8		2.5	V
C _{IN}	Transceiver capacitance	Capacitance to ground on each line			20	pF
I	Hi-Z State Data Line Leakage	$0V < V_{IN} < 3.3V$	-5		+5	μA
R _{EXT}	Recommended External USB Series Resistor	In series with each USB pin with ±5%		27		
Output Levels						
V _{OL}	Low Level Output	Measured with RL of 1.425 kOhm tied to 3.6V			0.3	V
V _{OH}	High Level Output	Measured with RL of 14.25 kOhm tied to GND	2.8			V
V _{CRS}	Output Signal Crossover Voltage	Measure conditions described in Figure 37-1	1.3		2.0	V

37.7.2 Switching Characteristics

Table 37-12. In Slow Mode

Symbol	Parameter	Conditions	Min	Typ	Max	Unit
t_{FR}	Transition Rise Time	$C_{LOAD} = 400 \text{ pF}$	75		300	ns
t_{FE}	Transition Fall Time	$C_{LOAD} = 400 \text{ pF}$	75		300	ns
t_{FRFM}	Rise/Fall time Matching	$C_{LOAD} = 400 \text{ pF}$	80		120	%

Table 37-13. In Full Speed

Symbol	Parameter	Conditions	Min	Typ	Max	Unit
t_{FR}	Transition Rise Time	$C_{LOAD} = 50 \text{ pF}$	4		20	ns
t_{FE}	Transition Fall Time	$C_{LOAD} = 50 \text{ pF}$	4		20	ns
t_{FRFM}	Rise/Fall Time Matching		90		111.11	%

Figure 37-1. USB Data Signal Rise and Fall Times

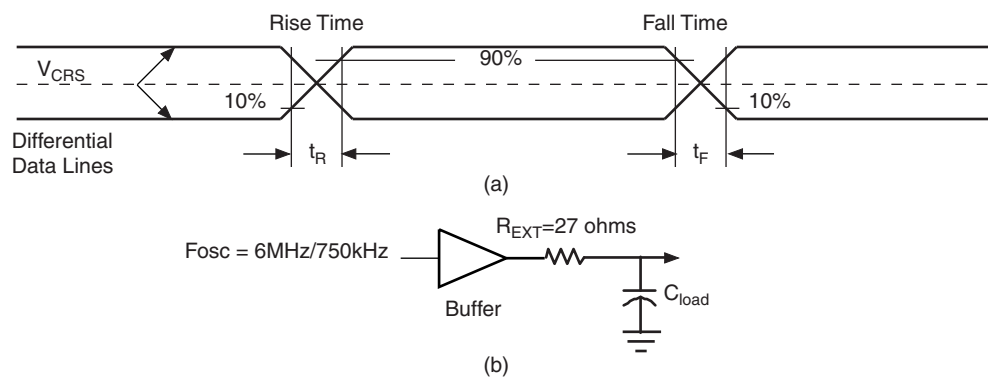

38. AT91RM9200 AC Characteristics

38.1 Applicable Conditions and Derating Data

38.1.1 Conditions and Timings Computation

The delays are given as typical values in the following conditions:

- $V_{DDIOM} = 3.3V$
- $V_{DDCORE} = 1.8V$
- Ambient Temperature = 25°C
- Load Capacitance = 0 pF
- The output level change detection is $(0.5 \times V_{DDIOM})$.
- The input level is $(0.3 \times V_{DDIOM})$ for a low-level detection and is $(0.7 \times V_{DDIOM})$ for a high-level detection.

The minimum and maximum values given in the AC characteristics tables of this datasheet take into account process variation and design. In order to obtain the timing for other conditions, the following equation should be used:

$$t = \delta_{T^{\circ}} \times \left((\delta_{VDDCORE} \times t_{DATASHEET}) + (\delta_{VDDIOM} \times \sum C_{SIGNAL} \times \delta_{CSIGNAL}) \right)$$

where:

- $\delta_{T^{\circ}}$ is the derating factor in temperature given in [Figure 38-1 on page 640](#).
- $\delta_{VDDCORE}$ is the derating factor for the Core Power Supply given in [Figure 38-2 on page 640](#).
- $t_{DATASHEET}$ is the minimum or maximum timing value given in this datasheet for a load capacitance of 0 pF.
- δ_{VDDIOM} is the derating factor for the IOM Power Supply given in [Figure 38-3 on page 641](#).
- C_{SIGNAL} is the capacitance load on the considered output pin⁽¹⁾.
- $\delta_{CSIGNAL}$ is the load derating factor depending on the capacitance load on the related output pins given in Min and Max in this datasheet.

The input delays are given as typical values.

Note: 1. The user must take into account the package capacitance load contribution (C_{IN}) described in [Table 37-2, "DC Characteristics," on page 632](#).

38.1.2 Temperature Derating Factor

Figure 38-1. Derating Curve for Different Operating Temperatures

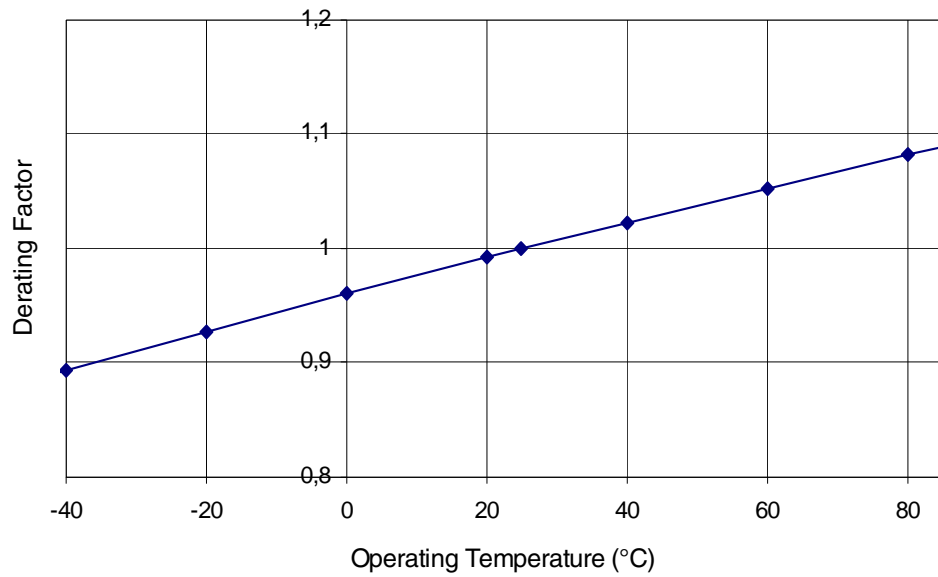

38.1.3 V_{DDCORE} Voltage Derating Factor

Figure 38-2. Derating Curve for Different Core Supply Voltages

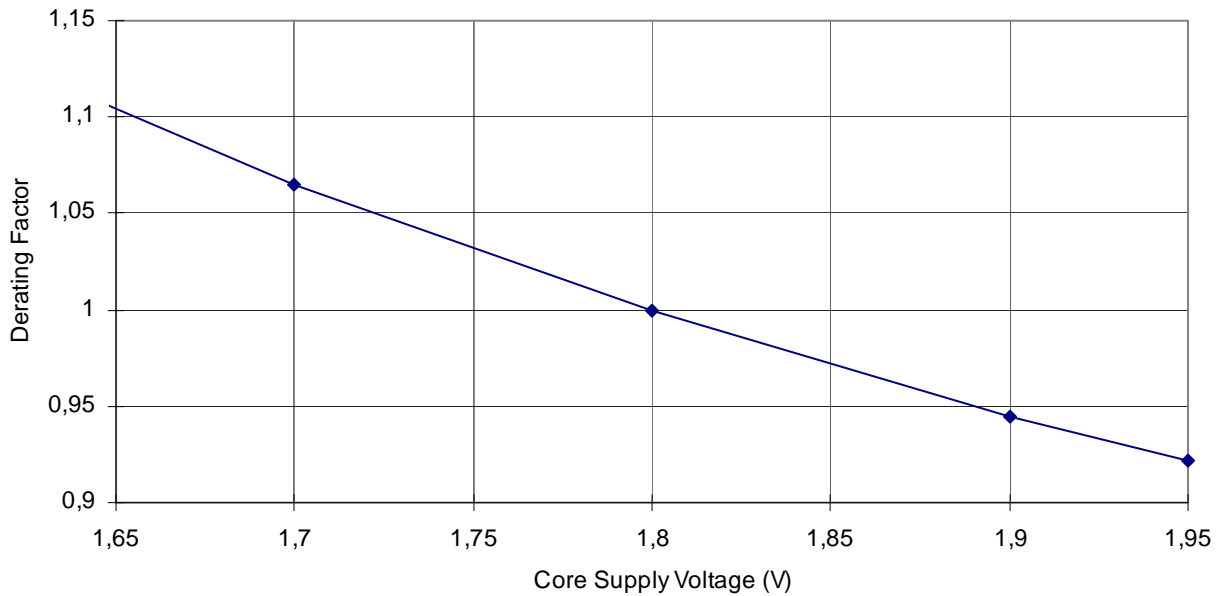

38.1.4 V_{DDIOM} Voltage Derating Factor

Figure 38-3. Derating Curve for Different IO Supply Voltages

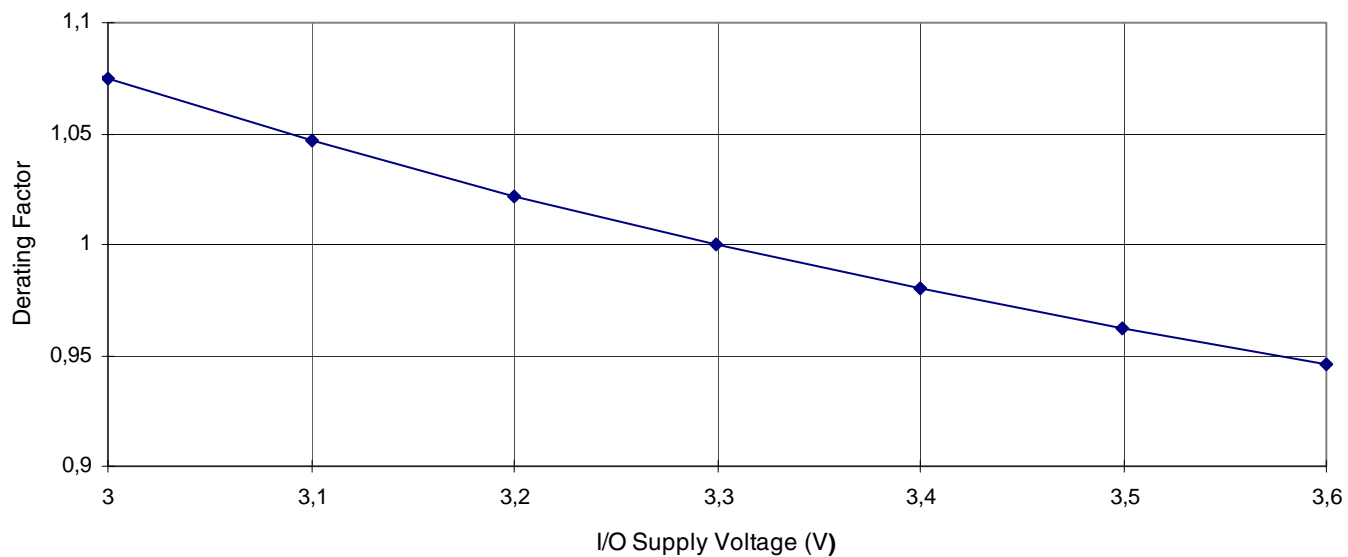

Note: The derating factor in this example is applicable only to timings related to output pins.

38.2 EBI Timings

38.2.1 SMC Signals Relative to MCK

Table 38-1, Table 38-2 and Table 38-3 show timings relative to operating condition limits defined in the section 38.1.1 “Conditions and Timings Computation” on page 639.

Table 38-1. General-purpose SMC Signals

Symbol	Parameter	Conditions	Min	Max	Units
SMC ₁	MCK Falling to NUB Valid	C _{NUB} = 0 pF	5.0	7.5	ns
		C _{NUB} derating	0.028	0.045	ns/pF
SMC ₂	MCK Falling to NLB/A0 Valid	C _{NLB} = 0 pF	4.9	7.5	ns
		C _{NLB} derating	0.028	0.045	ns/pF
SMC ₃	MCK Falling to A1 - A25 Valid	C _{ADD} = 0 pF	4.9	7.4	ns
		C _{ADD} derating	0.028	0.045	ns/pF
SMC ₄	MCK Falling to Chip Select Change (No Address to Chip Select Setup)	C _{NCS} = 0 pF	4.3	6.5	ns
		C _{NCS} derating	0.028	0.045	ns/pF
SMC ₅	MCK Falling to Chip Select Active (Address to Chip Select Setup) ⁽¹⁾	C _{NCS} = 0 pF	(nacss × t _{CPMCK}) + 4.3 ⁽²⁾	(nacss × t _{CPMCK}) + 6.5 ⁽²⁾	ns
		C _{NCS} derating	0.028	0.045	ns/pF
SMC ₆	Chip Select Inactive to MCK Falling (Address to Chip Select Setup) ⁽¹⁾	C _{NCS} = 0 pF	(nacss × t _{CPMCK}) + 4.4 ⁽²⁾	(nacss × t _{CPMCK}) + 6.5 ⁽²⁾	ns
		C _{NCS} derating	-0.028	-0.045	ns/pF
SMC ₇	NCS Minimum Pulse Width (Address to Chip Select Setup) ⁽¹⁾	C _{NCS} = 0 pF	$\frac{((n + 2) - (2 \times \text{nacss}))}{\times t_{CPMCK}}$ ^{(2) (3)}		ns
SMC ₈	NWAIT Minimum Pulse Width ⁽¹⁾		t _{CPMCK}		ns

- Notes:
1. The derating factor is not to be applied to t_{CPMCK}.
 2. nacss = Number of Address to Chip Select Setup Cycles inserted.
 3. n = Number of standard Wait States inserted.

Table 38-2. SMC Write Signals

Symbol	Parameter	Conditions	Min	Max	Units
SMC ₁₀	MCK Rising to NWR Active (No Wait States) ⁽⁵⁾	C _{NWR} = 0 pF	4.8	7.2	ns
		C _{NWR} derating	0.028	0.045	ns/pF
SMC ₁₁	MCK Rising to NWR Active (Wait States)	C _{NWR} = 0 pF	4.8	7.2	ns
		C _{NWR} derating	0.028	0.045	ns/pF
SMC ₁₂	MCK Falling to NWR Inactive (No Wait States) ⁽⁵⁾	C _{NWR} = 0 pF	4.8	7.2	ns
		C _{NWR} derating	0.028	0.045	ns/pF
SMC ₁₃	MCK Rising to NWR Inactive (Wait States)	C _{NWR} = 0 pF	4.8	7.2	ns
		C _{NWR} derating	0.028	0.045	ns/pF
SMC ₁₄	MCK Rising to D0 - D15 Out Valid	C _{DATA} = 0 pF	4.1	7.9	ns
		C _{DATA} derating	0.028	0.044	ns/pF
SMC ₁₅	NWR High to NUB Change ⁽⁵⁾	C _{NUB} = 0 pF	3.4		ns
		C _{NUB} derating	0.028		ns/pF
SMC ₁₆	NWR High to NLB/A0 Change ⁽⁵⁾	C _{NLB} = 0 pF	3.7		ns
		C _{NLB} derating	0.028		ns/pF
SMC ₁₇	NWR High to A1 - A25 Change ⁽⁵⁾	C _{ADD} = 0 pF	3.3		ns
		C _{ADD} derating	0.028		ns/pF
SMC ₁₈	NWR High to Chip Select Inactive ⁽⁵⁾	C _{NCS} = 0 pF	3.3		ns
		C _{NCS} derating	0.028		ns/pF
SMC ₁₉	Data Out Valid before NWR High (No Wait States) ^{(1) (5)}	C = 0 pF	t _{CHMCK} - 0.8		ns
		C _{DATA} derating	- 0.044		ns/pF
		C _{NWR} derating	0.045		ns/pF
SMC ₂₀	Data Out Valid before NWR High (Wait States) ^{(1) (5)}	C = 0 pF	n x t _{CPMCK} - 0.6 ⁽²⁾		ns
		C _{DATA} derating	- 0.044		ns/pF
		C _{NWR} derating	0.045		ns/pF
SMC ₂₁	Data Out Valid after NWR High (No Wait States) ^{(1) (5)}	C = 0 pF	t _{CLMCK} - 1.0		ns
		C _{DATA} derating	0.044		ns/pF
		C _{NWR} derating	- 0.045		ns/pF
SMC ₂₂	Data Out Valid after NWR High (Wait States without Hold Cycles) ^{(1) (5)}	C = 0 pF	t _{CHMCK} - 1.2		ns
		C _{DATA} derating	0.044		ns/pF
		C _{NWR} derating	- 0.045		ns/pF
SMC ₂₃	Data Out Valid after NWR High (Wait States with Hold Cycles) ^{(1) (5)}	C = 0 pF	h x t _{CPMCK} - 1.1 ⁽⁴⁾		ns
		C _{DATA} derating	0.044		ns/pF
		C _{NWR} derating	- 0.045		ns/pF

Table 38-2. SMC Write Signals (Continued)

Symbol	Parameter	Conditions	Min	Max	Units
SMC ₂₄	Data Out Valid before NCS High (Address to Chip Select Setup Cycles) ⁽¹⁾	C = 0 pF	$((n + 1) - nacss) \times t_{CPMCK} + t_{CHMCK} - 1.4$ ^{(2) (3)}		ns
		C _{DATA} derating	- 0.044		ns/pF
		C _{NCS} derating	0.045		ns/pF
SMC ₂₅	Data Out Valid after NCS High (Address to Chip Select Setup Cycles) ⁽¹⁾	C = 0 pF	$nacss \times t_{CPMCK} - 0.4$ ⁽³⁾		ns
		C _{DATA} derating	0.044		ns/pF
		C _{NCS} derating	- 0.045		ns/pF
SMC ₂₆	NWR Minimum Pulse Width (No Wait States) ^{(1) (5)}	C _{NWR} = 0 pF	$t_{CHMCK} - 0.1$		ns
		C _{NWR} derating	0.002		ns/pF
SMC ₂₇	NWR Minimum Pulse Width (Wait States) ^{(1) (5)}	C _{NWR} = 0 pF	$n \times t_{CPMCK}$ ⁽²⁾		ns
		C _{NWR} derating	0.002		ns/pF
SMC ₂₈	NWR Minimum Pulse Width (Address to Chip Select Setup Cycles) ⁽¹⁾	C _{NWR} = 0 pF	$(n + 1) \times t_{CPMCK}$ ⁽²⁾		ns
		C _{NWR} derating	0.002		ns/pF

- Notes:
1. The derating factor is not to be applied to t_{CLMCK} , t_{CHMCK} or t_{CPMCK} .
 2. n = Number of standard Wait States inserted.
 3. nacss = Number of Address to Chip Select Setup Cycles inserted.
 4. h = Number of Hold Cycles inserted.
 5. Not applicable when Address to Chip Select Setup Cycles are inserted.

Table 38-3. SMC Read Signals

Symbol	Parameter	Conditions	Min	Max	Units
SMC ₂₉	MCK Falling to NRD Active ^{(1) (7)}	C _{NRD} = 0 pF	4.5	6.8	ns
		C _{NRD} derating	0.028	0.045	ns/pF
SMC ₃₀	MCK Rising to NRD Active ⁽²⁾	C _{NRD} = 0 pF	4.7	7.0	ns
		C _{NRD} derating	0.028	0.045	ns/pF
SMC ₃₁	MCK Falling to NRD Inactive ^{(1) (7)}	C _{NRD} = 0 pF	4.5	6.8	ns
		C _{NRD} derating	0.028	0.045	ns/pF
SMC ₃₂	MCK Falling to NRD Inactive ⁽²⁾	C _{NRD} = 0 pF	4.5	6.8	ns
		C _{NRD} derating	0.028	0.045	ns/pF
SMC ₃₃	D0-D15 in Setup before MCK Falling ⁽⁸⁾		0.8		ns
SMC ₃₄	D0-D15 in Hold after MCK Falling ⁽⁹⁾		1.7		ns
SMC ₃₅	NRD High to NUB Change ⁽³⁾	C _{NUB} = 0 pF	$(h \times t_{CPMCK}) + 0.5$ ⁽⁶⁾	$(h \times t_{CPMCK}) + 0.8$ ⁽⁶⁾	ns
		C _{NUB} derating	0.028	0.045	ns/pF
		C _{NRD} derating	-0.028	-0.045	ns/pF
SMC ₃₆	NRD High to NLB/A0 Change ⁽³⁾	C _{NLB} = 0 pF	$(h \times t_{CPMCK}) + 0.4$ ⁽⁶⁾	$(h \times t_{CPMCK}) + 0.7$ ⁽⁶⁾	ns
		C _{NLB} derating	0.028	0.045	ns/pF
		C _{NRD} derating	-0.028	-0.045	ns/pF
SMC ₃₇	NRD High to A1-A25 Change ⁽³⁾	C _{ADD} = 0 pF	$(h \times t_{CPMCK}) + 0.3$ ⁽⁶⁾	$(h \times t_{CPMCK}) + 0.6$ ⁽⁶⁾	ns
		C _{ADD} derating	0.028	0.045	ns/pF
		C _{NRD} derating	-0.028	-0.045	ns/pF
SMC ₃₈	NRD High to Chip Select Inactive ⁽³⁾	C _{NCS} = 0 pF	$(h \times t_{CPMCK}) - 0.3$ ⁽⁶⁾	$(h \times t_{CPMCK}) - 0.2$ ⁽⁶⁾	ns
		C _{NCS} derating	0.028	0.045	ns/pF
		C _{NRD} derating	-0.028	-0.045	ns/pF
SMC ₃₉	Chip Select Inactive to NRD High ⁽³⁾	C _{NCS} = 0 pF	$(nacss \times t_{CPMCK}) + 0.2$ ⁽⁵⁾	$(nacss \times t_{CPMCK}) + 0.3$ ⁽⁵⁾	ns
		C _{NCS} derating	- 0.028	- 0.045	ns/pF
		C _{NRD} derating	0.028	0.045	ns/pF
SMC ₄₀	Data Setup before NRD High ⁽⁸⁾	C _{NRD} = 0 pF	7.5		ns
		C _{NRD} derating	0.045		ns/pF
SMC ₄₁	Data Hold after NRD High ⁽⁹⁾	C _{NRD} = 0 pF	-3.4		ns
		C _{NRD} derating	- 0.028		ns/pF
SMC ₄₂	Data Setup before NCS High	C _{NRD} = 0 pF	7.3		ns
		C _{NRD} derating	0.045		ns/pF

Table 38-3. SMC Read Signals (Continued)

Symbol	Parameter	Conditions	Min	Max	Units
SMC ₄₃	Data Hold after NCS High	C _{NRD} = 0 pF	-3.2		ns
		C _{NRD} derating	- 0.028		ns/pF
SMC ₄₄	NRD Minimum Pulse Width ^{(1) (3) (7)}	C _{NRD} = 0 pF	$n \times t_{CPMCK} - 0.02$ ⁽⁴⁾		ns
		C _{NRD} derating	0.002		ns/pF
SMC ₄₅	NRD Minimum Pulse Width ^{(2) (3) (7)}	C _{NRD} = 0 pF	$n \times t_{CHMCK} + t_{CHMCK} - 0.2$ ⁽⁴⁾		ns
		C _{NRD} derating	0.002		ns/pF
SMC ₄₆	NRD Minimum Pulse Width ^{(2) (3)}	C _{NRD} = 0 pF	$((n + 1) \times t_{CHMCK}) + t_{CHMCK} - 0.2$ ⁽⁴⁾		ns
		C _{NRD} derating	0.002		ns/pF

- Notes:
1. Early Read Protocol.
 2. Standard Read Protocol.
 3. The derating factor is not to be applied to t_{CHMCK} or t_{CPMCK} .
 4. n = Number of standard Wait States inserted.
 5. naccs = Number of Address to Chip Select Setup Cycles inserted.
 6. h = Number of Hold Cycles inserted.
 7. Not applicable when Address to Chip Select Setup Cycles are inserted.
 8. Only one of these two timings needs to be met.
 9. Only one of these two timings needs to be met.

Figure 38-4. SMC Signals Relative to MCK in Memory Interface Mode

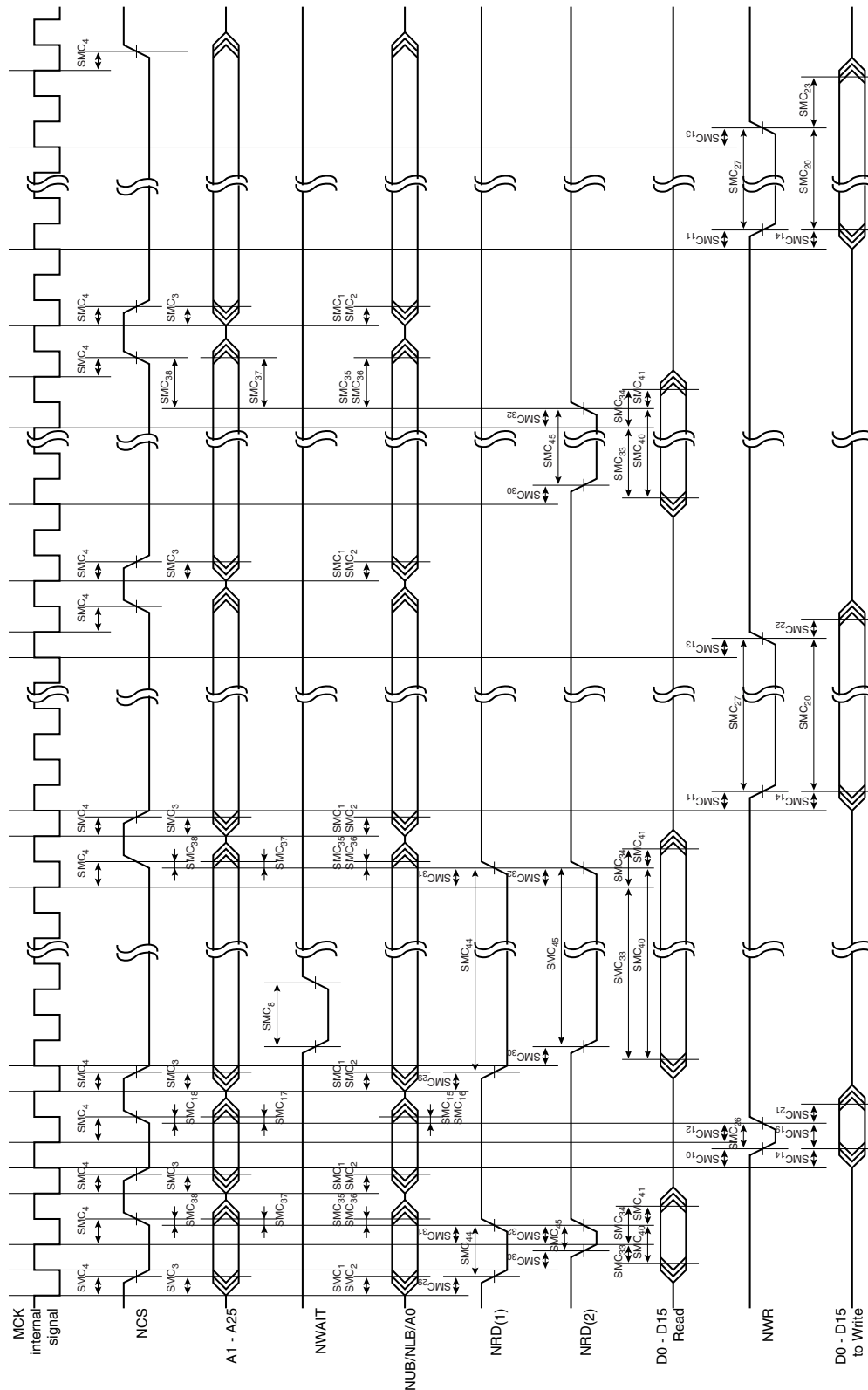

- Notes:
1. Early Read Protocol
 2. Standard Read Protocol with or without Setup and Hold Cycles.

Figure 38-5. SMC Signals Relative to MCK in LCD Interface Mode

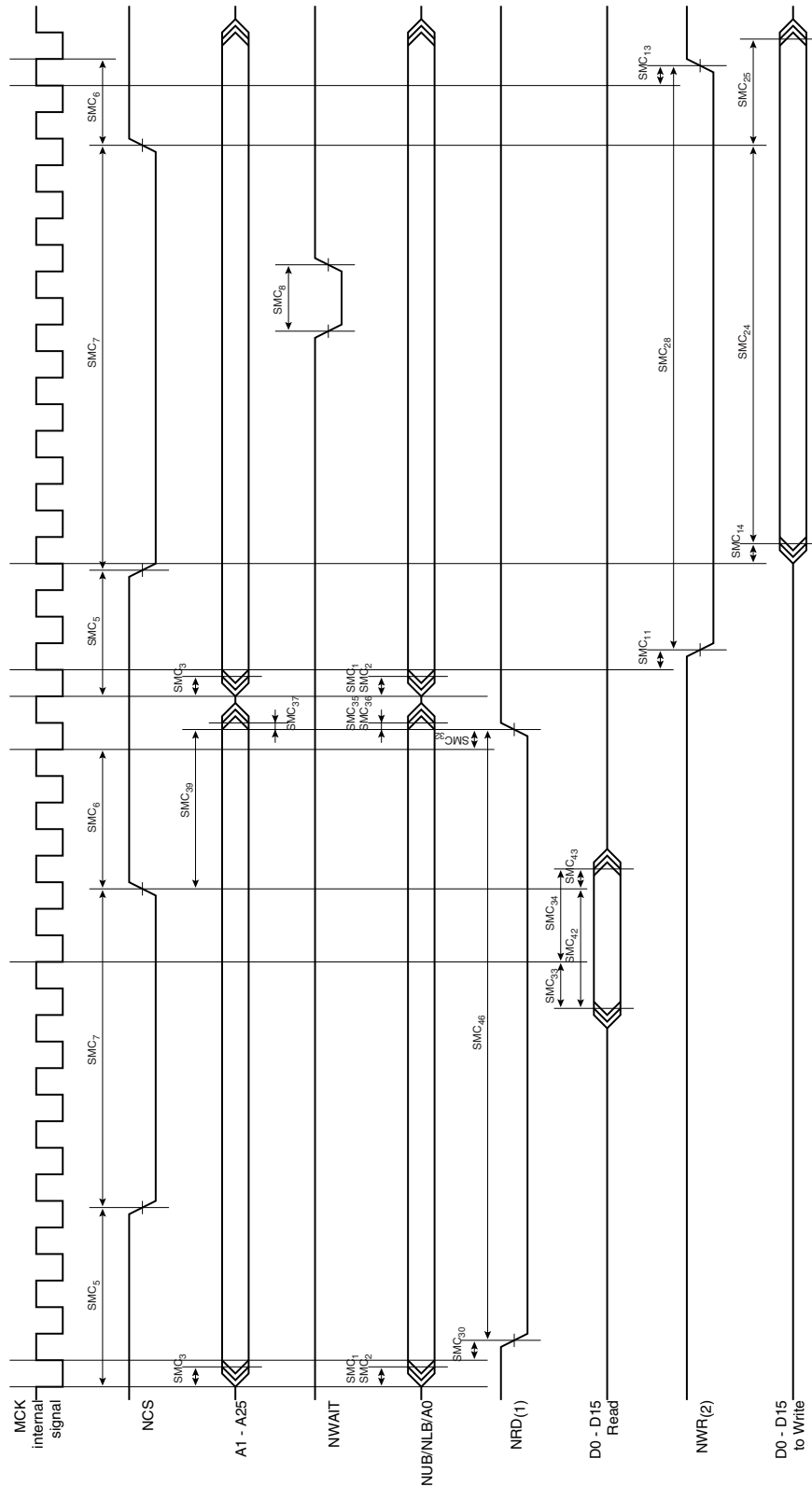

- Notes:
1. Standard Read Protocol only.
 2. With standard Wait States inserted only.

38.2.2 SDRAMC Signals Relative to SDCK

Table 38-4 and Table 38-5 below show timings relative to operating condition limits defined in the section 38.1.1 “Conditions and Timings Computation” on page 639.

Table 38-4. SDRAMC Clock Signal

Symbol	Parameter	Conditions	Min	Max	Units
$1/(t_{CPSDCK})$	SDRAM Controller Clock Frequency			80.0	MHz
t_{CPSDCK}	SDRAM Controller Clock Period		12.5		ns
t_{CHSDCK}	SDRAM Controller Clock High Half-Period		5.6		ns
t_{CLSDCK}	SDRAM Controller Clock Low Half-Period		6.9		ns
$t_{MCKtoSDCK_RISING}$	MCK Rising to SDCK Rising		5.381	8.038	ns
$t_{MCKtoSDCK_FALLING}$	MCK Falling to SDCK Falling		4.832	7.219	ns

Table 38-5. SDRAMC Signals

Symbol	Parameter	Conditions	Min	Max	Units
SDRAMC ₁	SDCKE High before SDCK Rising Edge ⁽¹⁾	$C_{SDCKE} = 0$ pF	$t_{CLMCK} + 1.2$		ns
		C_{SDCKE} derating	- 0.015		ns/pF
SDRAMC ₂	SDCKE Low after SDCK Rising Edge ⁽¹⁾	$C_{SDCKE} = 0$ pF	$t_{CHMCK} - 1.4$		ns
		C_{SDCKE} derating	0.023		ns/pF
SDRAMC ₃	SDCKE Low before SDCK Rising Edge ⁽¹⁾	$C_{SDCKE} = 0$ pF	$t_{CLMCK} + 1.0$		ns
		C_{SDCKE} derating	- 0.015		ns/pF
SDRAMC ₄	SDCKE High after SDCK Rising Edge ⁽¹⁾	$C_{SDCKE} = 0$ pF	$t_{CHMCK} - 1.7$		ns
		C_{SDCKE} derating	0.023		ns/pF
SDRAMC ₅	SDCS Low before SDCK Rising Edge ⁽¹⁾	$C_{SDCS} = 0$ pF	$t_{CLMCK} + 1.2$		ns
		C_{SDCS} derating	- 0.028		ns/pF
SDRAMC ₆	SDCS High after SDCK Rising Edge ⁽¹⁾	$C_{SDCS} = 0$ pF	$t_{CHMCK} - 1.9$		ns
		C_{SDCS} derating	0.045		ns/pF
SDRAMC ₇	RAS Low before SDCK Rising Edge ⁽¹⁾	$C_{RAS} = 0$ pF	$t_{CLMCK} + 0.6$		ns
		C_{RAS} derating	- 0.015		ns/pF
SDRAMC ₈	RAS High after SDCK Rising Edge ⁽¹⁾	$C_{RAS} = 0$ pF	$t_{CHMCK} - 1.1$		ns
		C_{RAS} derating	0.023		ns/pF
SDRAMC ₉	SDA10 Change before SDCK Rising Edge ⁽¹⁾	$C_{SDA10} = 0$ pF	$t_{CLMCK} + 0.8$		ns
		C_{SDA10} derating	- 0.015		ns/pF
SDRAMC ₁₀	SDA10 Change after SDCK Rising Edge ⁽¹⁾	$C_{SDA10} = 0$ pF	$t_{CHMCK} - 1.2$		ns
		C_{SDA10} derating	0.023		ns/pF
SDRAMC ₁₁	Address Change before SDCK Rising Edge ⁽¹⁾	$C_{ADD} = 0$ pF	$t_{CLMCK} + 0.6$		ns
		C_{ADD} derating	- 0.028		ns/pF

Table 38-5. SDRAMC Signals (Continued)

Symbol	Parameter	Conditions	Min	Max	Units
SDRAMC ₁₂	Address Change after SDCK Rising Edge ⁽¹⁾	C _{ADD} = 0 pF	t _{CHMCK} - 1.5		ns
		C _{ADD} derating	0.045		ns/pF
SDRAMC ₁₃	Bank Change before SDCK Rising Edge ⁽¹⁾	C _{BA} = 0 pF	t _{CLMCK} + 0.8		ns
		C _{BA} derating	- 0.028		ns/pF
SDRAMC ₁₄	Bank Change after SDCK Rising Edge ⁽¹⁾	C _{BA} = 0 pF	t _{CHMCK} - 1.6		ns
		C _{BA} derating	0.045		ns/pF
SDRAMC ₁₅	CAS Low before SDCK Rising Edge ⁽¹⁾	C _{CAS} = 0 pF	t _{CLMCK} + 0.9		ns
		C _{CAS} derating	- 0.015		ns/pF
SDRAMC ₁₆	CAS High after SDCK Rising Edge ⁽¹⁾	C _{CAS} = 0 pF	t _{CHMCK} - 1.5		ns
		C _{CAS} derating	0.023		ns/pF
SDRAMC ₁₇	DQM Change before SDCK Rising Edge ⁽¹⁾	C _{DQM} = 0 pF	t _{CLMCK} + 0.7		ns
		C _{DQM} derating	- 0.028		ns/pF
SDRAMC ₁₈	DQM Change after SDCK Rising Edge ⁽¹⁾	C _{DQM} = 0 pF	t _{CHMCK} - 1.4		ns
		C _{DQM} derating	0.045		ns/pF
SDRAMC ₁₉	D0-D15 in Setup before SDCK Rising Edge		1.3		ns
SDRAMC ₂₀	D0-D15 in Hold after SDCK Rising Edge		0.03		ns
SDRAMC ₂₁	D16-D31 in Setup before SDCK Rising Edge		2.0		ns
SDRAMC ₂₂	D16-D31 in Hold after SDCK Rising Edge		-0.2		ns
SDRAMC ₂₃	SDWE Low before SDCK Rising Edge	C _{SDWE} = 0 pF	t _{CLMCK} + 1.0		ns
		C _{SDWE} derating	- 0.015		ns/pF
SDRAMC ₂₄	SDWE High after SDCK Rising Edge	C _{SDWE} = 0 pF	t _{CHMCK} - 1.8		ns
		C _{SDWE} derating	0.023		ns/pF
SDRAMC ₂₅	D0-D15 Out Valid before SDCK Rising Edge	C = 0 pF	t _{CLMCK} - 2.7		ns
		C _{DATA} derating	-0.044		ns/pF
SDRAMC ₂₆	D0-D15 Out Valid after SDCK Rising Edge	C = 0 pF	t _{CHMCK} - 2.4		ns
		C _{DATA} derating	0.044		ns/pF
SDRAMC ₂₇	D16-D31 Out Valid before SDCK Rising Edge	C = 0 pF	t _{CLMCK} - 3.2		ns
		C _{DATA} derating	-0.044		ns/pF
SDRAMC ₂₈	D16-D31 Out Valid after SDCK Rising Edge	C = 0 pF	t _{CHMCK} - 2.4		ns
		C _{DATA} derating	0.044		ns/pF

Note: 1. The derating factor is not to be applied to t_{CLMCK} or t_{CHMCK}.

Figure 38-6. SDRAMC Signals Relative to SDCK

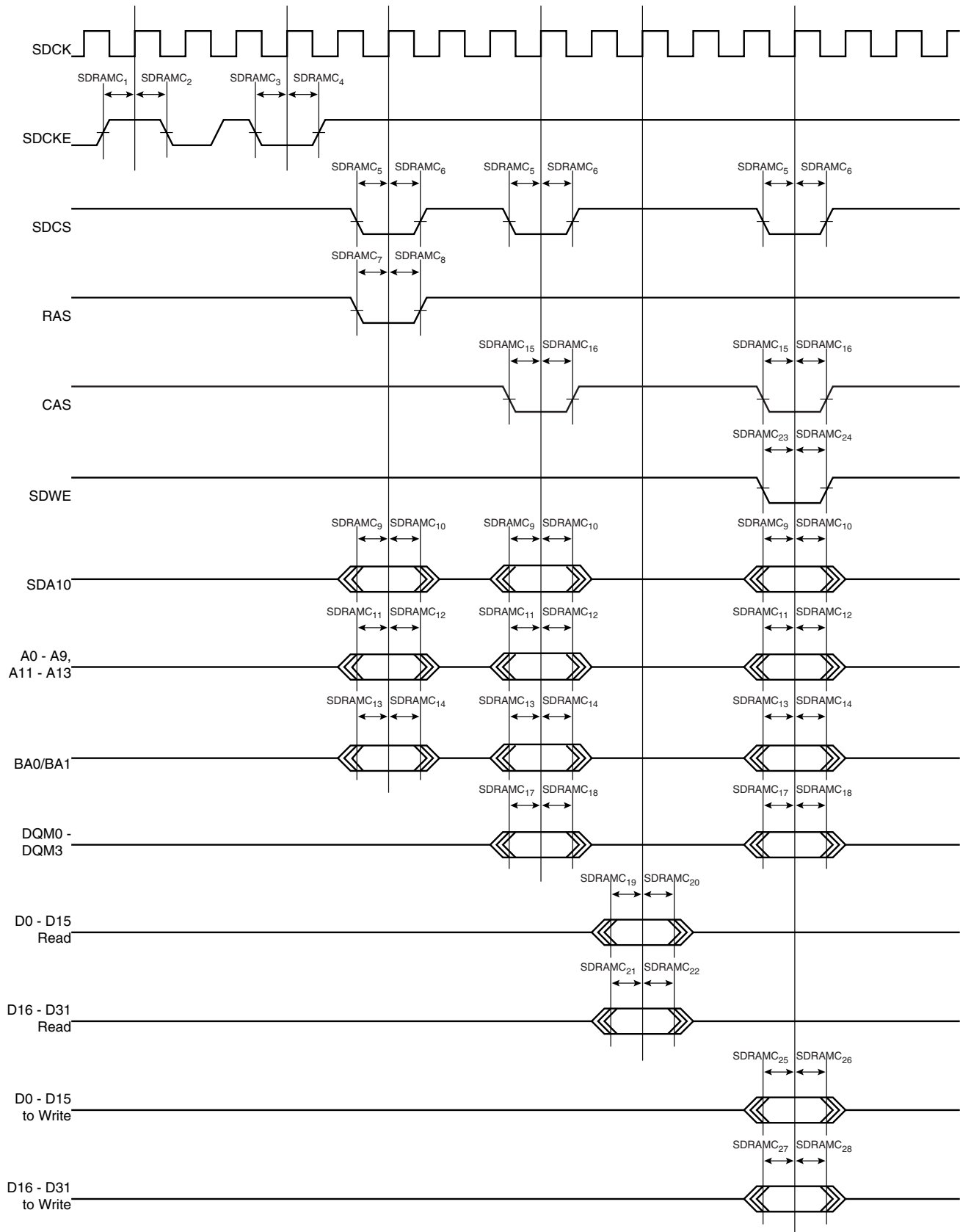

38.2.3 BFC Signals Relative to BFCK

Table 38-6, Table 38-7 and Table 38-8 show timings relative to operating condition limits defined in the section “Conditions and Timings Computation” on page 639.

Table 38-6. BFC Clock Signal

Symbol	Parameter	Conditions	Min	Max	Units
$1/(t_{CPBFCK})$	BF Controller Clock Frequency	BFCK is MCK ⁽¹⁾		80.0	MHz
		BFCK is MCK/2 ⁽²⁾		40.0	MHz
		BFCK is MCK/4 ⁽³⁾		20.0	MHz
t_{CPBFCK}	BF Controller Clock Period	BFCK is MCK ⁽¹⁾	12.5		ns
		BFCK is MCK/2 ⁽²⁾	25.0		ns
		BFCK is MCK/4 ⁽³⁾	50.0		ns
t_{CHBFCK}	BF Controller Clock High Half-Period	BFCK is MCK ⁽¹⁾	6.5		ns
		BFCK is MCK/2 ⁽²⁾	12.8		ns
		BFCK is MCK/4 ⁽³⁾	25.3		ns
t_{CLBFCK}	BF Controller Clock Low Half-Period	BFCK is MCK ⁽¹⁾	6.1		ns
		BFCK is MCK/2 ⁽²⁾	12.3		ns
		BFCK is MCK/4 ⁽³⁾	24.8		ns

- Notes: 1. Field BFCC = 1 in Register BFC_MR, see Section 20.7.1 “Burst Flash Controller Mode Register” on page 227.
 2. Field BFCC = 2 in Register BFC_MR, see Section 20.7.1 “Burst Flash Controller Mode Register” on page 227.
 3. Field BFCC = 3 in Register BFC_MR, see Section 20.7.1 “Burst Flash Controller Mode Register” on page 227.

Table 38-7. BFC Signals in Asynchronous Mode

Symbol	Parameter	Conditions	Min	Max	Units
BFC ₁	BFCK Rising to A1-A25 Valid ⁽¹⁾	$C_{ADD} = 0$ pF		$t_{CLBFCK} - 0.2$	ns
		C_{ADD} derating		0.045	ns/pF
BFC ₂	BFCK Rising to A1-A25 Change ⁽¹⁾	$C_{ADD} = 0$ pF	$t_{CLBFCK} - 1.0$		ns
		C_{ADD} derating	0.028		ns/pF
BFC ₃	BFCK Falling to BFAVD Active ⁽¹⁾	$C_{BFAVD} = 0$ pF	$t_{CLBFCK} - 1.1$	$t_{CLBFCK} - 0.3$	ns
		C_{BFAVD} derating	0.028	0.044	ns/pF
BFC ₄	BFCK Falling to BFAVD Inactive ⁽¹⁾	$C_{BFAVD} = 0$ pF	$t_{CLBFCK} - 1.8$	$t_{CLBFCK} + 0.2$	ns
		C_{BFAVD} derating	0.028	0.044	ns/pF
BFC ₅	BFAVD Minimum Pulse Width ⁽¹⁾	$C_{BFAVD} = 0$ pF	$t_{CPBFCK} + 1.0$		ns
		C_{BFAVD} derating	0.001		ns/pF
BFC ₆	BFCK Rising to BFOE Active	$C_{BFOE} = 0$ pF	- 0.4	0.1	ns
		C_{BFOE} derating	0.028	0.044	ns/pF
BFC ₇	BFCK Rising to BFOE Inactive	$C_{BFOE} = 0$ pF	- 1.1	0.7	ns
		C_{BFOE} derating	0.028	0.044	ns/pF

Table 38-7. BFC Signals in Asynchronous Mode (Continued)

Symbol	Parameter	Conditions	Min	Max	Units
BFC ₈	BFOE Minimum Pulse Width ⁽¹⁾	C _{BFOE} = 0 pF	$(a \times t_{CPBFCK}) + 0.9$ ⁽²⁾		ns
		C _{BFOE} derating	0.001		ns/pF
BFC ₉	D0-D15 in Setup before BFCK Rising Edge ⁽⁵⁾		- 0.1		ns
BFC ₁₀	D0-D15 in Hold after BFCK Rising Edge ⁽⁶⁾		1.0		ns
BFC ₁₁	Data Setup before BFOE High ⁽⁵⁾	C _{BFOE} = 0 pF	- 0.9		ns
		C _{BFOE} derating	- 0.044		ns/pF
BFC ₁₂	Data Hold after BFOE High ⁽⁶⁾	C _{BFOE} = 0 pF	2.0		ns
		C _{BFOE} derating	0.028		ns/pF
BFC ₁₃	BFCK Rising to BFWF Active	C _{BFWF} = 0 pF	- 0.6	- 0.05	ns
		C _{BFWF} derating	0.028	0.044	ns/pF
BFC ₁₄	BFCK Rising to BFWF Inactive	C _{BFWF} = 0 pF	- 1.3	0.5	ns
		C _{BFWF} derating	0.028	0.044	ns/pF
BFC ₁₅	BFCK Rising to AD0-AD15 Valid ^{(1) (4)}	C _{DATA} = 0 pF		t _{CLBFCK} - 0.2	ns
		C _{DATA} derating		0.044	ns/pF
BFC ₁₆	BFCK Rising to AD0-AD15 Not Valid ^{(1) (4)}	C _{DATA} = 0 pF	t _{CLBFCK} - 0.8		ns
		C _{DATA} derating	0.028		ns/pF
BFC ₁₇	Data Out Valid before BFCK Rising ^{(1) (5)}	C _{DATA} = 0 pF	t _{CLBFCK} + 0.5		ns
		C _{DATA} derating	-0.044		ns/pF
BFC ₁₈	Data Out Valid after BFCK Rising ^{(1) (6)}	C _{DATA} = 0 pF	t _{CHBFCK} + 0.7		ns
		C _{DATA} derating	0.028		ns/pF
BFC ₁₉	Data Out Valid before BFWF High ^{(1) (5)}	C = 0 pF	t _{CLBFCK} - 0.5		ns
		C _{DATA} derating	- 0.028		ns/pF
		C _{BFWF} derating	0.044		ns/pF
BFC ₂₀	Data Out Valid after BFWF High ^{(1) (6)}	C = 0 pF	t _{CHBFCK} + 0.3		ns
		C _{DATA} derating	0.028		ns/pF
		C _{BFWF} derating	- 0.044		ns/pF
BFC ₂₁	Number of Address Valid Latency Cycles ⁽¹⁾		$((a + 1) \times t_{CPBFCK})$ ⁽²⁾	$((a + 1) \times t_{CPBFCK})$ ⁽²⁾	ns
BFC ₂₂	Number of Output Enable Latency Cycles ⁽¹⁾		$(o \times t_{CPBFCK})$ ⁽³⁾	$(o \times t_{CPBFCK})$ ⁽³⁾	ns

- Notes:
1. The derating factor is not to be applied to t_{CPBFCK}.
 2. a = Number of Address Valid Latency Cycles defined in the BFC_MR AVL field.
 3. o = Number of Output Enable Latency Cycles defined in the BFC_MR OEL field.
 4. Applicable only with multiplexed Address and Data Buses.
 5. Only one of these two timings needs to be met.
 6. Only one of these two timings needs to be met.



Figure 38-7. BFC Signals Relative to BFCK in Asynchronous Mode

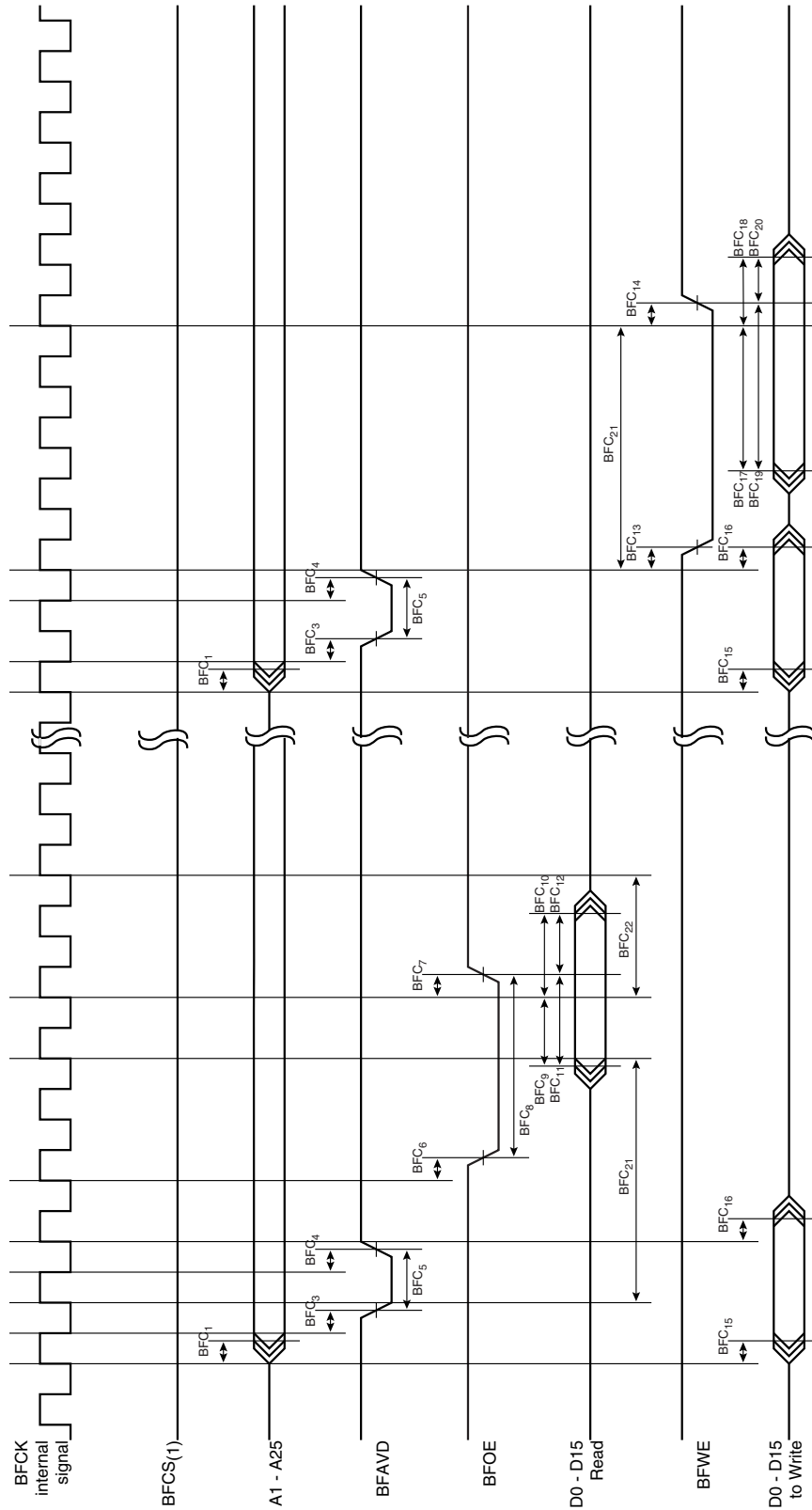

Note: 1. BFCs is asserted as soon as the BFCOM field in BFC_MR is different from 0.

Table 38-8. BFC Signals in Burst Mode

Symbol	Parameter	Conditions	Min	Max	Units
BFC ₁	BFCK Rising to A1-A25 Valid ⁽¹⁾	C _{ADD} = 0 pF		t _{CLBFCK} - 0.2	ns
		C _{ADD} derating		0.045	ns/pF
BFC ₂	BFCK Rising to A1-A25 Change ⁽¹⁾	C _{ADD} = 0 pF	t _{CLBFCK} - 1.0		ns
		C _{ADD} derating	0.028		ns/pF
BFC ₃	BFCK Falling to BFAVD Active ⁽¹⁾	C _{BFAVD} = 0 pF	t _{CLBFCK} - 1.1	t _{CLBFCK} - 0.3	ns
		C _{BFAVD} derating	0.028	0.044	ns/pF
BFC ₄	BFCK Falling to BFAVD Inactive ⁽¹⁾	C _{BFAVD} = 0 pF	t _{CLBFCK} - 1.8	t _{CLBFCK} + 0.2	ns
		C _{BFAVD} derating	0.028	0.044	ns/pF
BFC ₅	BFAVD Minimum Pulse Width ⁽¹⁾	C _{BFAVD} = 0 pF	t _{CPBFCK} + 1.0		ns
		C _{BFAVD} derating	0.001		ns/pF
BFC ₆	BFCK Rising to BFOE Active	C _{BFOE} = 0 pF	- 0.4	0.1	ns
		C _{BFOE} derating	0.028	0.044	ns/pF
BFC ₇	BFCK Rising to BFOE Inactive	C _{BFOE} = 0 pF	- 1.1	0.7	ns
		C _{BFOE} derating	0.028	0.044	ns/pF
BFC ₉	D0-D15 in Setup before BFCK Rising Edge		- 0.1		ns
BFC ₁₀	D0-D15 in Hold after BFCK Rising Edge		1.0		ns
BFC ₁₅	BFCK Rising to AD0-AD15 Valid ⁽¹⁾ ⁽⁴⁾	C _{DATA} = 0 pF		t _{CLBFCK} - 0.2	ns
		C _{DATA} derating		0.044	ns/pF
BFC ₁₆	BFCK Rising to AD0-AD15 Not Valid ⁽¹⁾ ⁽⁴⁾	C _{DATA} = 0 pF	t _{CLBFCK} - 0.8		ns
		C _{DATA} derating	0.028		ns/pF
BFC ₂₁	Number of Address Valid Latency Cycles ⁽¹⁾		((a + 1) × t _{CPBFCK}) ⁽²⁾	((a + 1) × t _{CPBFCK}) ⁽²⁾	ns
BFC ₂₂	Number of Output Enable Latency Cycles ⁽¹⁾		(o × t _{CPBFCK}) ⁽³⁾	(o × t _{CPBFCK}) ⁽³⁾	ns
BFC ₂₃	BFCK Falling to BFBAA Active ⁽¹⁾	C _{BFBAA} = 0 pF	t _{CLBFCK} - 1.0	t _{CLBFCK} - 0.1	ns
		C _{BFBAA} derating	0.028	0.044	ns/pF
BFC ₂₄	BFCK Falling to BFBAA Inactive ⁽¹⁾	C _{BFBAA} = 0 pF	t _{CLBFCK} - 1.7	t _{CLBFCK} + 0.1	ns
		C _{BFBAA} derating	0.028	0.044	ns/pF
BFC ₂₅	BFRDY Change Hold after BFCK Rising Edge		0.1		ns
BFC ₂₆	BFRDY Change Setup before BFCK Rising Edge		0.3		ns

- Notes:
1. The derating factor is not to be applied to t_{CPBFCK}.
 2. a = Number of Address Valid Latency Cycles defined in the BFC_MR AVL field.
 3. o = Number of Output Enable Latency Cycles defined in the BFC_MR OEL field.
 4. Applicable only with multiplexed Address and Data Buses.

Figure 38-8. BFC Signals Relative to BFCK in Burst Mode

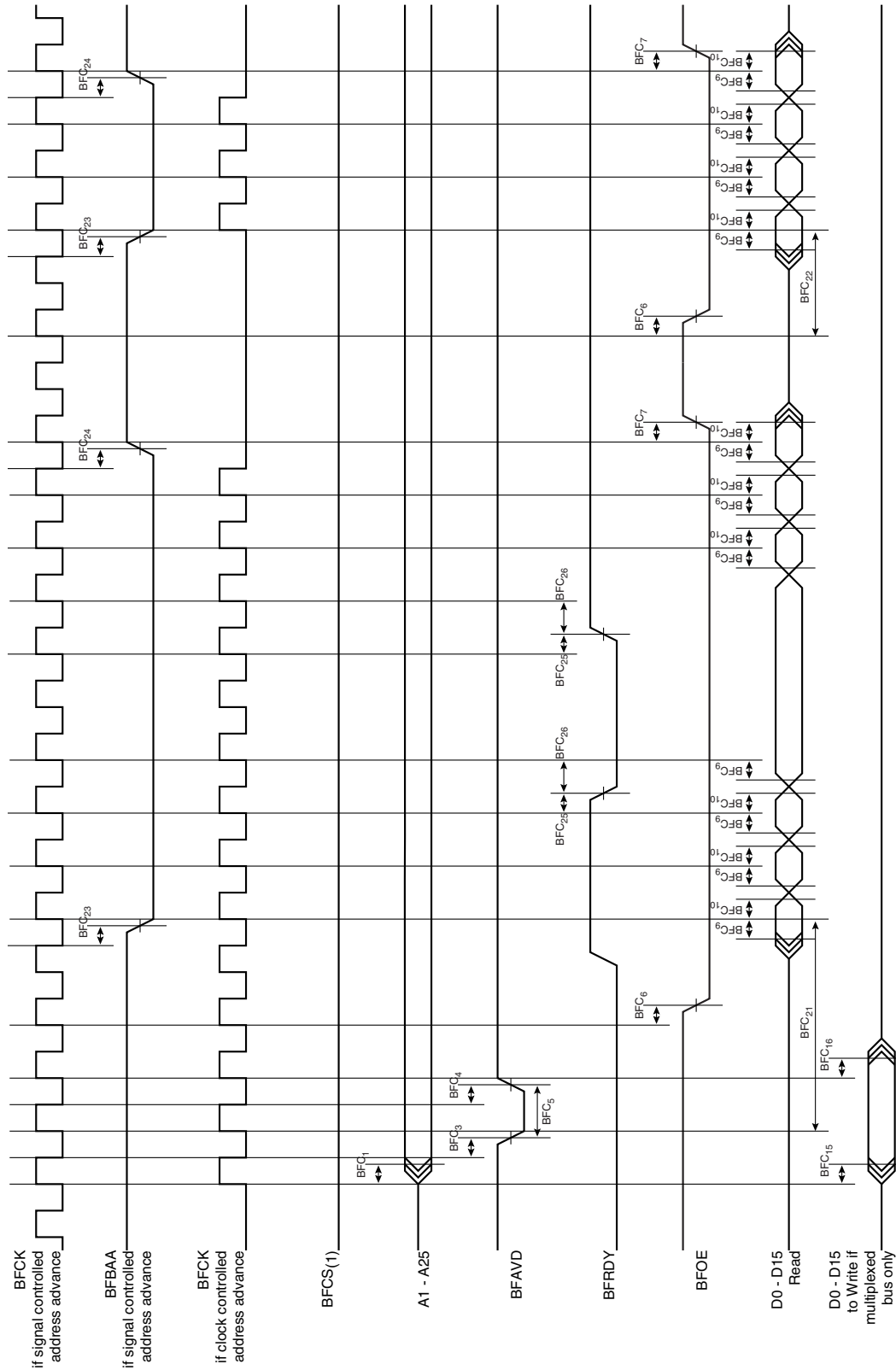

Note: 1. BFCS is asserted as soon as the BFCOM field in BFC_MR is different from 0.

38.3 JTAG/ICE Timings

38.3.1 ICE Interface Signals

Table 38-9 shows timings relative to operating condition limits defined in the section [Section 38.1.1 “Conditions and Timings Computation”](#) on page 639

Table 38-9. ICE Interface Timing Specifications

Symbol	Parameter	Conditions	Min	Max	Units
ICE ₀	NTRST Minimum Pulse Width		20.00		ns
ICE ₁	NTRST High Recovery to TCK High		0.86		ns
ICE ₂	NTRST High Removal from TCK High		0.90		ns
ICE ₃	TCK Low Half-period		8.00		ns
ICE ₄	TCK High Half-period		8.00		ns
ICE ₅	TCK Period		20.00		ns
ICE ₆	TDI, TMS, Setup before TCK High		-0.13		ns
ICE ₇	TDI, TMS, Hold after TCK High		0.10		ns
ICE ₈	TDO Hold Time	C _{TDO} = 0 pF	4.17		ns
		C _{TDO} derating	0		ns/pF
ICE ₉	TCK Low to TDO Valid	C _{TDO} = 0 pF		6.49	ns
		C _{TDO} derating		0.028	ns/pF

Figure 38-9. ICE Interface Signals

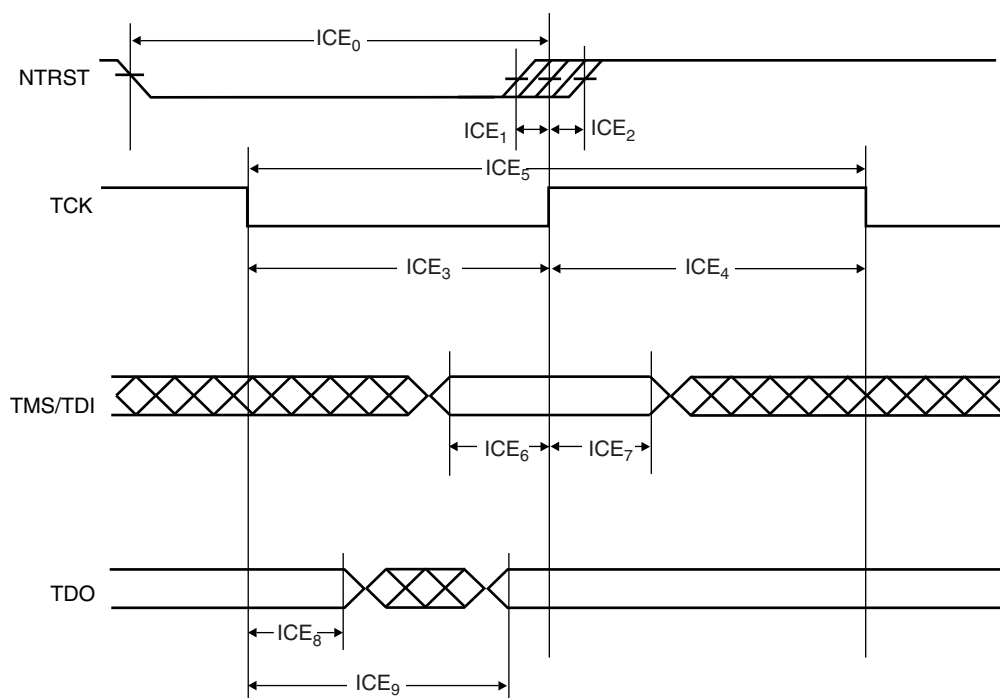

38.3.2 JTAG Interface Signals

Table 38-10 shows timings relative to operating condition limits defined in the section 38.1.1 “Conditions and Timings Computation” on page 639.

Table 38-10. JTAG Interface Timing Specifications

Symbol	Parameter	Conditions	Min	Max	Units
JTAG ₀	NTRST Minimum Pulse Width		20.00		ns
JTAG ₁	NTRST High Recovery to TCK High		-0.16		ns
JTAG ₂	NTRST High Recovery to TCK Low		-0.16		ns
JTAG ₃	NTRST High Removal from TCK High		-0.07		ns
JTAG ₄	NTRST High Removal from TCK Low		-0.07		ns
JTAG ₅	TCK Low Half-period		8.00		ns
JTAG ₆	TCK High Half-period		8.00		ns
JTAG ₇	TCK Period		20.00		ns
JTAG ₈	TDI, TMS Setup before TCK High		0.01		ns
JTAG ₉	TDI, TMS Hold after TCK High		3.21		ns
JTAG ₁₀	TDO Hold Time	C _{TDO} = 0 pF	2.38		ns
		C _{TDO} derating	0		ns/pF
JTAG ₁₁	TCK Low to TDO Valid	C _{TDO} = 0 pF		4.66	ns
		C _{TDO} derating		0.028	ns/pF
JTAG ₁₂	Device Inputs Setup Time		-1.23		ns
JTAG ₁₃	Device Inputs Hold Time		3.81		ns
JTAG ₁₄	Device Outputs Hold Time	C _{OUT} = 0 pF	7.15		ns
		C _{OUT} derating	0		ns/pF
JTAG ₁₅	TCK to Device Outputs Valid	C _{OUT} = 0 pF		7.22	ns
		C _{OUT} derating		0.028	ns/pF

Figure 38-10. JTAG Interface Signals

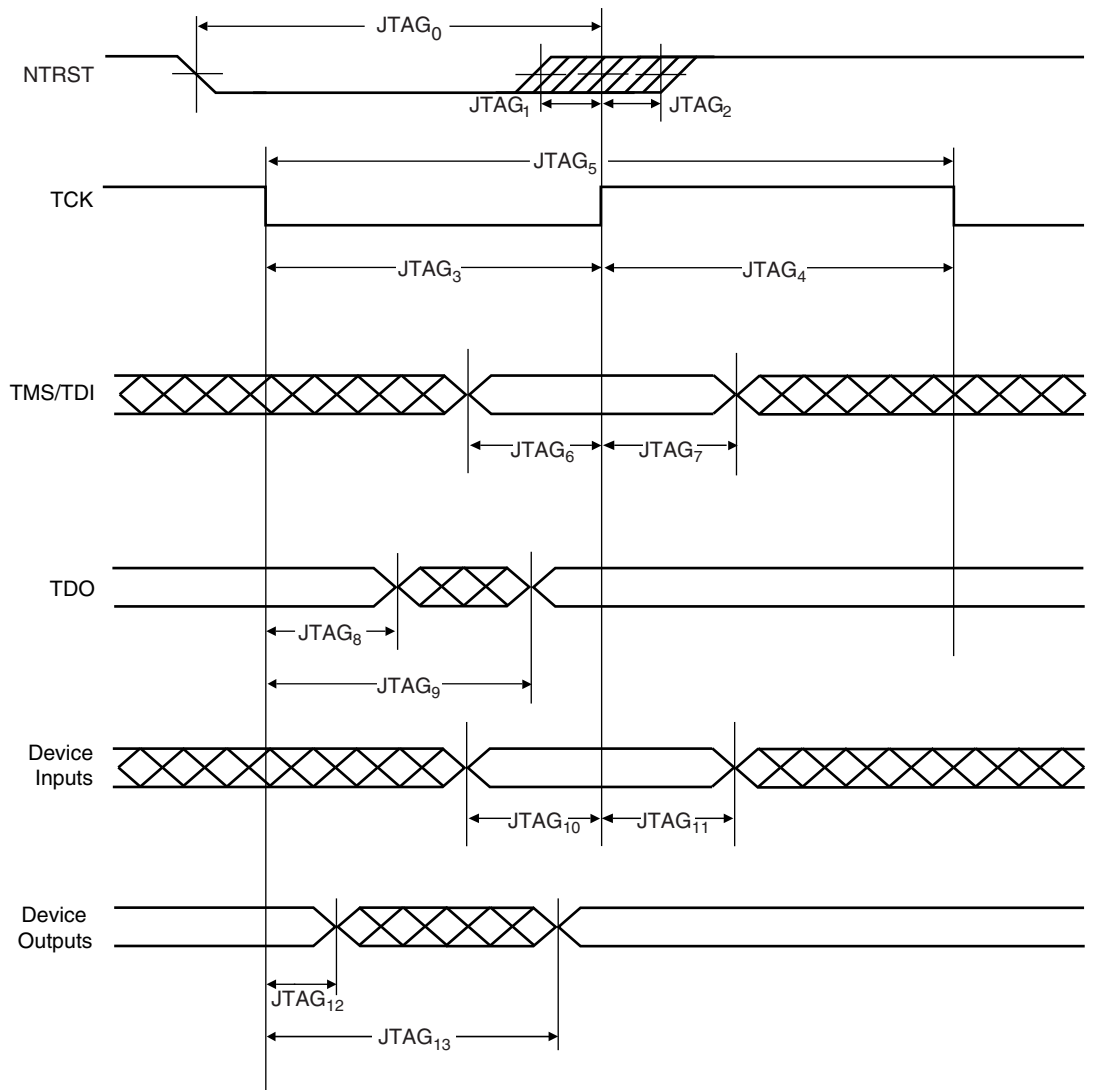

38.4 ETM Timings

38.4.1 Timings Data

Table 38-11 shows timings relative to operating condition limits defined in the section 38.1.1 “Conditions and Timings Computation” on page 639.

Table 38-11. ETM Timing Characteristics

Symbol	Parameter	Conditions	Min	Typ	Max	Units
$1/(t_{CPTCLK})$	Trace Clock Frequency			$1/(2 \times t_{CPPCK})$	86.54	MHz
t_{CPTCLK}	Trace Clock Period		11.56	$2 \times t_{CPPCK}$		ns
t_{CHTCLK}	TCLK High Half-period		$t_{CPTCLK}/2 + 0.02$			ns
t_{CLTCLK}	TCLK Low Half-period		$t_{CPTCLK}/2 - 0.02$			ns
ETM_0	Data Signals Out Valid before TCLK Rising Edge		$t_{CLTCLK} - 1.06$			ns
ETM_1	Data Signals Out Valid after TCLK Rising Edge	$C = 0 \text{ pF}$	$t_{CHTCLK} - 0.49$			ns
		C_{DATA} derating	0.044			ns/pF
ETM_2	Data Signals Out Valid before TCLK Falling Edge		$t_{CHTCLK} - 1.03$			ns
ETM_3	Data Signals Out Valid after TCLK Falling Edge	$C = 0 \text{ pF}$	$t_{CLTCLK} - 0.51$			ns
		C_{DATA} derating	0.044			ns/pF

Figure 38-11. ETM Signals

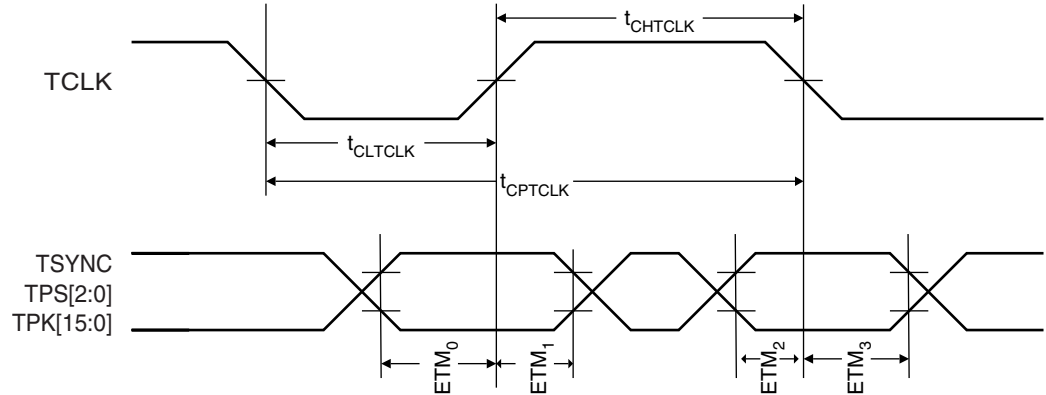

38.4.2 Design Considerations

When designing a PCB, it is important to keep the differences between trace length of ETM signals as small as possible to minimize skew between them. In addition, crosstalk on the trace port must be kept to a minimum as it can cause erroneous trace results. Stubs on these traces can cause unpredictable responses, thus it is recommended to avoid stubs on the trace lines.

The TCLK line should be series-terminated as close as possible to the microcontroller pins.

The maximum capacitance presented by the trace connector, cabling and interfacing logic must be less than 15 pF.

39. AT91RM9200 Mechanical Characteristics

39.1 Thermal and Reliability Considerations

39.1.1 Thermal Data

Table 39-1 summarizes the thermal resistance data depending on the package.

Table 39-1. Thermal Resistance Data

Symbol	Parameter	Condition	Package	Typ	Unit
θ_{JA}	Junction-to-ambient thermal resistance	Still Air	PQFP208	33.9	°C/W
			LFBGA256	35.6	
θ_{JC}	Junction-to-case thermal resistance		PQFP208	15.7	
			LFBGA256	7.7	

39.1.2 Reliability Data

The number of gates and the device die size are provided Table 39-2 so that the user can calculate reliability data for another standard and/or in another environmental model.

Table 39-2. Reliability Data

Parameter	Data	Unit
Number of Logic Gates	4461	K gates
Number of Memory Gates	2458	K gates
Device Die Size	33.9	mm ²

39.1.3 Junction Temperature

The average chip-junction temperature, T_J , in °C can be obtained from the following:

1. $T_J = T_A + (P_D \times \theta_{JA})$
2. $T_J = T_A + (P_D \times (\theta_{HEATSINK} + \theta_{JC}))$

where:

- θ_{JA} = package thermal resistance, Junction-to-ambient (°C/W), provided in [Table 39-1 on page 661](#).
- θ_{JC} = package thermal resistance, Junction-to-case thermal resistance (°C/W), provided in [Table 39-1 on page 661](#).
- $\theta_{HEAT\ SINK}$ = cooling device thermal resistance (°C/W), provided in the device datasheet.
- P_D = device power consumption (W) estimated from data provided in the section [37.5 "Power Consumption" on page 634](#).
- T_A = ambient temperature (°C).

From the first equation, the user can derive the estimated lifetime of the chip and decide if a cooling device is necessary or not. If a cooling device is to be fitted on the chip, the second equation should be used to compute the resulting average chip-junction temperature T_J in °C.

39.2 Package Drawings

Figure 39-1. 208-pin PQFP Package Drawing

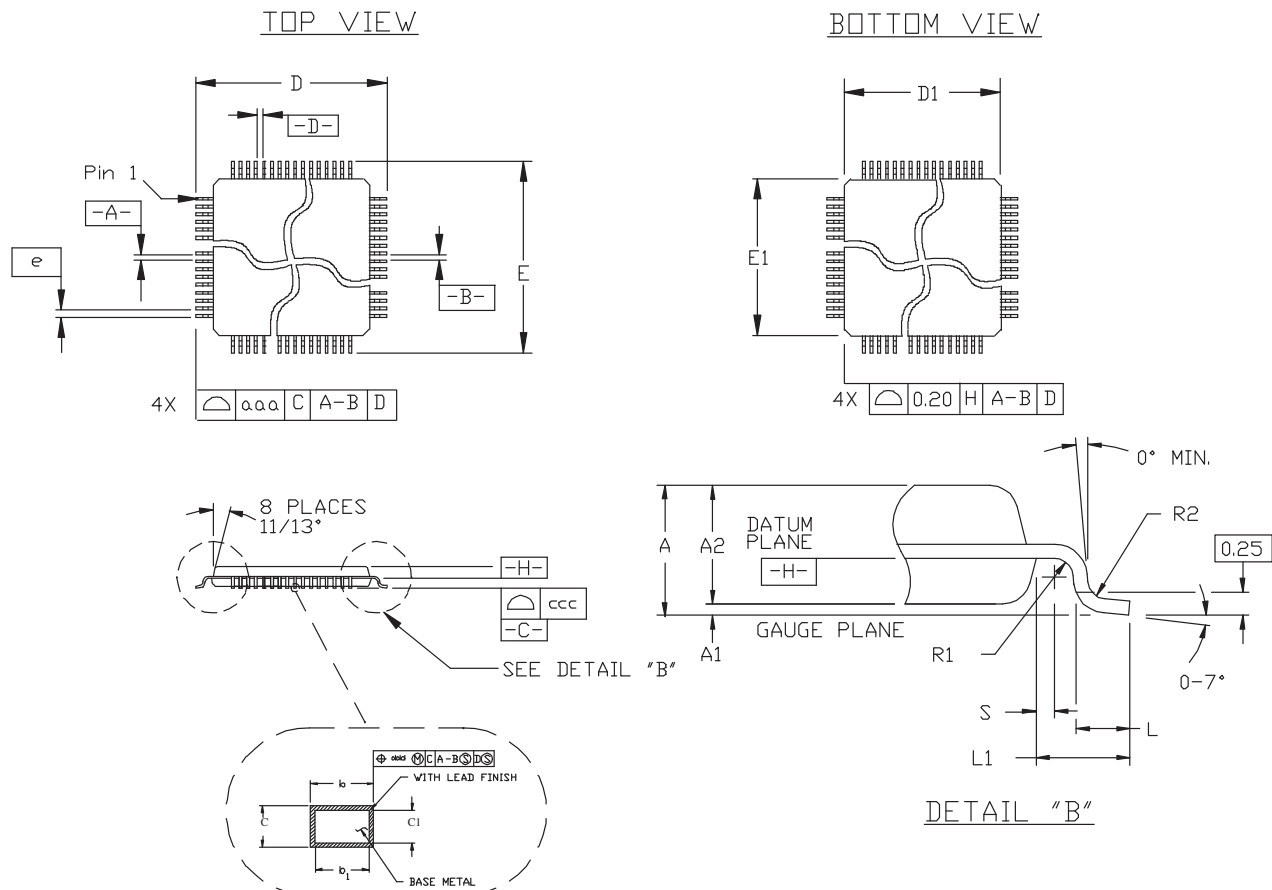

Table 39-3. 208-pin PQFP Package Dimensions (in mm)

Symbol	Min	Nom	Max	Symbol	Min	Nom	Max
c	0.11		0.23	b1	0.17	0.20	0.23
c1	0.11	0.15	0.19	ddd	0.10		
L	0.65	0.88	1.03	Tolerances of Form and Position			
L1	1.60 REF			aaa		0.25	
R2	0.13		0.3	ccc			0.1
R1	0.13			BSC			
S	0.4			D	31.20		
A	4.10			D1	28.00		
A1	0.25		0.50	E	31.20		
A2	3.20	3.40	3.60	E1	28.00		
b	0.17		0.27	e	0.50		

Table 39-4. Device and 208-pin Package Maximum Weight

Package Type	Weight	Unit
Standard and Green	5809	mg

Table 39-5. 208-pin PQFP

Package Type	Moisture Sensitivity Level
Standard and Green	3

Table 39-6. Package Reference

Package Type	Standard
Standard	JEDEC Drawing MS-022
Green	JEDEC Drawing MS-212
	JESD97 Classification: e2

The Green package respects the recommendations of the NEMI User Group.

Figure 39-2. 256-ball BGA Package Drawing

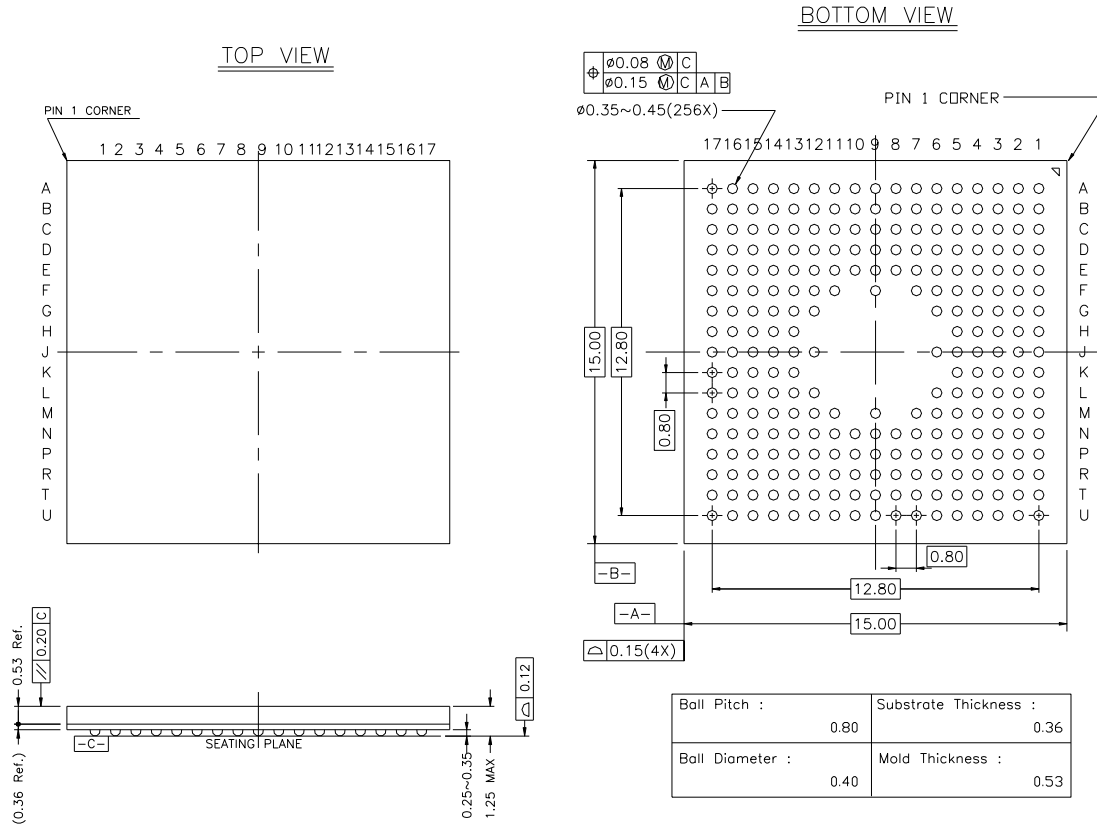

Table 39-7. Device and 256-ball BGA Package Maximum Weight

Package Type	Weight	Unit
Standard	620	mg
RoHS-compliant		

Table 39-8. 256-ball BGA Package Characteristics

Package Type	Moisture Sensitivity Level
Standard and RoHS-compliant	3

Table 39-9. Package Reference

Package Type	Standard
Standard	JEDEC Drawing MO-205E
RoHS-compliant	JEDEC Drawing MO-205E
	JESD97 Classification: e1

The RoHS-compliant package respects the recommendations of the NEMI User Group.

39.3 Soldering Profiles

39.3.1 Standard Packages

Table 39-10 gives the recommended soldering profile from J-STD-20.

Table 39-10. Soldering Profile

	Convection or IR/Convection	VPR
Average Ramp-up Rate (183· C to Peak)	3· C/sec. max.	10· C/sec.
Preheat Temperature 125· C ±25· C	120 sec. max	
Temperature Maintained Above 183· C	60 sec. to 150 sec.	
Time within 5· C of Actual Peak Temperature	10 sec. to 20 sec.	60 sec.
Peak Temperature Range	220 +5/-0· C or 235 +5/-0· C	215 to 219· C or 235 +5/-0· C
Ramp-down Rate	6· C/sec.	10· C/sec.
Time 25· C to Peak Temperature	6 min. max	

Small packages may be subject to higher temperatures if they are reflowed in boards with larger components. In this case, small packages may have to withstand temperatures of up to 235· C, not 220· C (IR reflow).

Recommended package reflow conditions depend on package thickness and volume. See Table 39-11.

Table 39-11. Recommended Package Reflow Conditions (LQFP and BGA)^{(1) (2)(3)}

Parameter	Temperature
Convection	220 +5/-0· C
VPR	215 to 219· C
IR/Convection	220 +5/-0· C

- Notes:
1. The packages are qualified by Atmel by using IR reflow conditions, not convection or VPR.
 2. By default, the package level 1 is qualified at 220· C (unless 235· C is stipulated).
 3. The body temperature is the most important parameter but other profile parameters such as total exposure time to hot temperature or heating rate may also influence component reliability.

A maximum of three reflow passes is allowed per component.

39.3.2 Green and RoHS-compliant Packages

Table 39-12 gives the recommended soldering profile from J-STD-20.

Table 39-12. Soldering Profile

Profile Feature	PQFP208 Green Package ⁽¹⁾⁽²⁾	BGA256 RoHS Compliant Package ⁽³⁾
Average Ramp-up Rate (183· C to Peak)	3· C/sec. max.	3· C/sec. max
Preheat Temperature 175· C ±25· C	180 sec. max	180 sec. max
Temperature Maintained Above 217· C	60 sec. to 150 sec.	60 sec. to 150 sec.
Time within 5· C of Actual Peak Temperature	20sec. to 40 sec.	20 sec. to 40 sec.
Peak Temperature Range	260· C	260· C
Ramp-down Rate	6· C/sec. max	6· C/sec. max
Time 25· C to Peak Temperature	8 min. max	8 min. max

- Notes:
1. The package is certified to be backward compatible with Pb/Sn soldering profile.
 2. Atmel Green Definition is: RoHS and <900ppm Br; <900ppm Sb; no TBTO use, no Phosphorous use.
 3. It is recommended to apply a soldering temperature higher than 250°.



40. AT91RM9200 Ordering Information

Table 40-1. Ordering Information

Ordering Code	Package	Package Type	Temperature Operating Range
AT91RM9200-QU-002	PQFP 208	Green	Industrial (-40° C to 85° C)
AT91RM9200-CJ-002	BGA 256	RoHS-compliant	

41. AT91RM9200 Errata

41.1 Marking

All devices are marked with the Atmel logo and the ordering code.

Additional marking may be in one of the following formats:

$\begin{array}{l} \text{YYWW} \quad \text{V} \square \\ \text{XXXXXXXXXX} \quad \underline{\text{ARM}} \end{array}$

where

- “YY”: manufactory year
- “WW”: manufactory week
- “V”: revision
- “XXXXXXXXXX”: lot number

$\begin{array}{l} \text{ZZZZZZ} \text{ YYWW} \square \\ \text{XXXXXXXXXX} \quad \underline{\text{ARM}} \end{array}$

where

- “ZZZZZZ”: manufactory number
- “YY”: manufactory year
- “WW”: manufactory week
- “XXXXXXXXXX”: lot number

41.2 EBI

41.2.1 A24 not wired internally between the EBI and the PIO

A24 is not wired internally between the EBI and the PIO. Use only PIO mode on it.

Problem Fix/Workaround

Due to this error, static memories over 16M bytes per chip select cannot be used. To interface 32-Mbyte memories and over, the user must use two memory chips connected on two different chip selects.

41.3 EMAC

41.3.1 Using Receive frames and buffers not word-aligned

A dead lock may appear when the Ethernet MAC attempts to store a new received valid frame while there are no more rx buffer descriptors. This appears only when the received frame length is not a multiple of 4 bytes. In this configuration, even if the application enables new receive buffer descriptors, all packets will be rejected.

Problem Fix/Workaround

The software workaround is to disable and re-enable the receive function in the network function register ETH_CTL each time a buffer is not available (RBNA in the status register).

```
ETH_CTL &= ~0x00000004 ;
ETH_CTL |= 0x00000004 ;
```

Note that an interrupt can be activated for the RBNA detection.

Another workaround is to align the address of the receive buffer descriptor on a boundary of 16 Words (address 0xaaaa aa00, 0xaaaa aa40, 0xaaaa aa80,.....)

41.4 MCI

41.4.1 Data Endianess inversion from the MCI to MMC or SD Card

The data endianess is inverted when writing or reading to or from an MMC or SD card. If the MCI interface is exclusively used to read/write from/to a dedicated card the inversion is not visible (two inversions). Furthermore, if the card is shared with other systems then endianess will not match. This endianess inversion concerns only data sectors and not command and response.

Problem Fix/Workaround

A software workaround consists of swapping the order of word bytes before writing and after reading.

41.4.2 Data Timeout Error Flag

As the data timeout error flag cannot rise, the MCI is stalled indefinitely waiting for the data start bit.

Problem Fix/Workaround

A STOP command must be sent with a software timeout.

41.4.3 STREAM command not supported

The STREAM READ/WRITE commands are not supported by the MCI.

Problem Fix/Workaround

None.

41.4.4 STOP during a WRITE_MULTIPLE_BLOCK command

The WRITE_MULTIPLE_BLOCK with a transfer size (PDC) not a multiple of the block length is not stopped by the STOP command.

Problem Fix/Workaround

Choose an appropriate size for the block length.

41.4.5 DTIP flag

The DTIP flag is not reset if STOP_COMMAND is received in the middle of a block data transfer.

Problem Fix/Workaround

None.

41.4.6 STOP command with SYNCHRONISED special command

A STOP command with SYNCHRONISED special command is sent after the block data transfer ends. During this time the MMCI receives data but the RXRDY flag is no longer asserted.

Problem Fix/Workaround

Do not send a STOP command with SYNCHRONISED special command.

41.4.7 Data FIFO and status bits

Do not read/write the Data FIFO if RXRDY/TXRDY status bits are not set.

Problem Fix/Workaround

None.

41.4.8 DATA FIFO problem with PDC

The shared FIFO is reset at the beginning of a transfer command.

Problem Fix/Workaround

So as to avoid losing data, it is mandatory to enable the PDC channel after writing to the command register. In order to achieve this sequence correctly, it is mandatory to disable all IT sources.

41.4.9 DATA_CRC_ERR flag never rises

The DATA_CRC_ERR (error flag) never rises during the checking of bad data CRC status sent by MMC/SD card after block writing.

Problem Fix/Workaround

CRC must be done by software.

41.4.10 STOP during a READ_MULTIPLE_BLOCK command

If the user sends a READ_MULTIPLE_BLOCK command and stops it by using a STOP_COMMAND in the middle of a data block transfer then the internal state of the MMCI controller stops in a bad state. After that the following read block (with READ_SINGLE_BLOCK or READ_MULTIPLE_BLOCK) will be entirely corrupted.

Problem Fix/Workaround

It consists in doing a software reset if RXRDY = 1 after the STOP_COMMAND. This flag indicates that the MMCI receives more data than the PDC has been settle to transfer. After this soft reset the MCI_CR, MCI_MR, MCI_DTOR, MCI_SDCR need to be reassigned.

41.4.11 Data write operation and number of bytes

The Data Write operation with a number of bytes less than 12 is impossible.

Problem Fix/Workaround

The PDC counters must always be equal to 12 bytes for data transfers lower than 12 bytes. The BLKLEN or BCNT field are used to specify the real count number.

41.5 PIO

41.5.1 NWAIT activity depends on use of PC6

NWAIT activity depends on use of PC6. The PC6 line multiplexes with the NWAIT function. As the PIO Controller is transparent in input, the level on the PC6 line has direct impact on the behavior of the EBI. In particular, driving the PC6 line to 0 might lead to a deadlock of the system.

Problem Fix/Workaround

Use PC6 carefully. In general, it is recommended to not use PC6 and to make sure the pull-up is enabled.

41.5.2 Output Data Status Register is always Read/Write

The programming of the register PIO_OWSR has no effect on the read/write features of PIO_ODSR, which is always read/write accessible.

Problem Fix/Workaround

None.

41.6 PMC

41.6.1 Constraints on the Master Clock selection sequence

The PMC_MCKR register must not be programmed in a single write operation.

Problem Fix/Workaround

The preferred programming sequence for the PMC_MCKR register is as follows:

1. Program the CSS field in the PMC_MCKR.
2. Wait for the MCKRDY bit to be set in the PMC_SR register.
3. Program the PRES field (in the PMC_MCKR).

An exception to this sequence occurs when the processor clock frequency is greater than the master clock frequency. In this case, the PRES field should be written first.

41.6.2 MCKRDY does not rise in some cases

When re-programming the Master Clock Register, if both fields PRES and CSS are written with the same values as the ones already stored, or if both fields are written with different values than

the ones already stored, the status bit MCKRDY does not rise. When one and only one of the fields PRES and CSS is changed, the MCKRDY bit operates normally.

Problem Fix/Workaround

If both fields must be re-programmed, carry out the change in two steps.

41.6.3 PMC, Clock Generator: Bad switching when writing PLL registers with same MUL and DIV values

When the fields MUL and DIV in the CKGR_PLLBR register are written with the same values as already programmed, the Master Clock signal switches to Main Clock (output of the Main Oscillator) until a different value is programmed in the register.

When the fields MUL and DIV in the CKGR_PLLAR register are written with the same values as already programmed, the Master Clock signal switches to Slow Clock (output of the 32768 Hz Oscillator) until a different value is programmed in the register.

Problem Fix/Workaround

The user must be sure that either the DIV or MUL field changes when setting the CKGR_PLLBR or CKGR_PLLAR register.

41.6.4 OSCBYPASS is not functional with PLLA

With PLLA, it is not possible to have an MCKRDY flag raised.

Problem Fix/Workaround

Even if MCKRDY flag does not raise with PLLA, it will not prevent you from switching on it.

You just need to wait for the PLLA lock time; for that program, PLLA then PLLB. When PLLB is ready, PLLA is ready too.

Main Oscillator in Bypass Mode: CKGR_MOR = 0x00000002

PLLA programming: CKGR_PLLAR = 0x20063E01

PLLB programming: CKGR_PLLBR = 0x10173F05

Wait PLLB LOCKB bit: PMC_SR will be 0x0000000C

Switch on PLLACK clock: PMC_MCKR -> 0x00000102

PMC_SR will be 0x0000000C

41.7 ROM Bootloader

ROM Bootloader: Limitation with 8-bit parallel memories.

Limitation with 8-bit parallel memories. In the internal Boot Rom program, version 1.0, the wait state number on CS0 is set to 0 during Boot ROM initialization. This gives an access time of 20 ns at 48 MHz Master Clock Frequency. This limitation of the ROM Bootloader applies to AT91RM9200 with the product number 58A07F.

Problem Fix/Workaround

None.

41.8 SDRAMC

41.8.1 SDRC_IMR can be written

The Interrupt Mask Register in the SDRAM Controller is not read-only. Thus, writing to it modifies the contents instead of having no effect.

Problem Fix/Workaround

None.

41.8.2 No wrap-around for SDRAM devices with two internal banks

In the case of SDRAM devices featuring two internal banks, when the physical address is higher than the memory size, the SDRAM controller does not wrap around. It activates virtual bank numbers three or four.

Problem Fix/Workaround

None.

41.8.3 No t_{RC} after refresh when low-power mode is enabled

When low-power mode is enabled and after a refresh command is sent to the SDRAM, the SDRAM Controller enters low-power mode by asserting SDCKE low. The t_{RC} timing between Auto-refresh and Low-power mode is not respected. As SDCKE is low, the INHIBIT and NOP commands are not sent to the SDRAM.

For the moment this warning has no effect on the correct functionality of the SDRAM.

Problem Fix/Workaround

None.

41.8.4 Some devices are not supported

The SDRAM controller does not support the following devices in 32-bit mode:

- 128 Mbit device: 32M*4bits: 4 banks/12 rows/11 columns
- 256 Mbit device: 64M*4bits: 4 banks/13 rows/11 columns

Problem Fix/Workaround

None.

41.8.5 Interrupt Disable Register

Writing 0 to the Interrupt Enable Register or to the Interrupt Disable Register modifies the value of Interrupt Mask Register.

Problem Fix/Workaround

None.

41.9 SMC

41.9.1 Address Bus continuously active

The address bus is continuously driven with the address of the current access, even if it is an internal one.

Problem Fix/Workaround

None.

41.9.2 16-bit write access constraints

When at least two SMC_CSR registers are programmed as follows:

- SMC_SCRx: With wait states ($1 < NWS < 127$), 16-bit data bus width, and byte write access (BAT field set to 0)
- SMC_CSRy: With wait states ($1 < NWS < 127$), 16-bit data bus width, and byte select access (BAT field set to 1),

the associated NCSx signal is not asserted for the write access.

Problem Fix/Workaround

For registers programmed with wait states and 16-bit data bus width configuration, the BAT fields in these registers must be programmed with the same value.

41.10 SPI

41.10.1 Slave Mode Receiver does not mask the highest data bits

If the SPI receives a frame followed by 8 bits of data, the user needs to mask the highest byte of the Receive Holding Register, as this data may be incorrect and not 0.

Problem Fix/Workaround

The user should implement the PDC. If the PDC is not implemented, the user should mask the highest byte of the Receive Holding register.

41.10.2 No chip select configuration change before end of current transfer

If the SPI is programmed in Master Mode and in Fixed Peripheral Mode, and data is being sent to a slave, the user has to wait for completion of the transfer before changing the slave number. Programming a new slave number (PCS) and/or a new DLYBCS field locks the SPI on the current slave.

Problem Fix/Workaround

The user should use the Variable Peripheral Mode.

41.10.3 NPCSx rises if no data is to be transmitted

If the SPI has sent all the data written in the SPI_TDR, the current NPCS rises immediately. This might be inconvenient in the case of several SPI peripherals requiring their chip select line to remain active until a complete data buffer has been transmitted. The PDC channel may be late in providing data to be transmitted when bus latencies are too high.

Problem Fix/Workaround

For high-speed applications, the relevant PIO pins can be used to manage the data transmission.

41.10.4 Mode Fault does not allow more than one Master on Chip Select 0

If Mode fault is disabled, Chip Select 0 cannot be driven by a component other than the SPI otherwise the transfer does not occur.

Problem Fix/Workaround

None.

41.11 SSC

41.11.1 Receiver does not take into account a start condition while receiving data

The SSC receiver does not support reception of the last data sequence of a frame that overlaps a new start of frame, regardless of the mode of detection of the start condition. For example, this prevents reception of the last data of a TDM bus.

Problem Fix/Workaround

None.

41.11.2 RXSYN and TXSYN not cleared when read

The status bits RXSYN and TXSYN are active during a complete serial clock period and are not immediately cleared when SSC_SR is read.

Problem Fix/Workaround

The user must enable the interrupt relevant to RXSYN and TXSYN.

41.11.3 Receiver Speed Limitations

- If RF is programmed as input, the maximum clock frequency is MCK divided by 2.
- If RF is programmed as output and RK is programmed as input, the maximum clock frequency is MCK divided by 6.
- If RF and RK are both programmed as output, the maximum clock frequency is MCK divided by 4.

Problem Fix/Workaround

None.

41.11.4 Transmitter Speed Limitations

- If both TF and TK are programmed as output, the maximum clock frequency is MCK divided by 4.
- If TF is programmed in output and TK is programmed as input, the maximum clock frequency is MCK divided by 8.
- If both TF and TK are programmed as input, the maximum clock frequency is MCK divided by 8.
- If TF is programmed in input and TK is programmed as output, the maximum clock frequency is MCK divided by 4.

Problem Fix/Workaround

None.

41.11.5 Disabling the SSC does not stop the Frame Synchronization signal generation

Generating RF can be stopped only by programming the FSOS field in SSC_RFMR to 0x0.

Generating TF can be stopped only by programming the FSOS field in SSC_TFMR to 0x0.

Problem Fix/Workaround

None.

41.11.6 No delay when start condition overlays data transmit

When transmission of data is programmed at the end of a frame and the start condition of the following frame is detected at the end of the current frame, the delay programmed by the STTDLY bit (in the SSC_RCMR and in the SSC_TCMR registers) is not performed on the next frame. Transmission starts immediately regardless of the programming of the field STTDLY.

Problem Fix/Workaround

None.

41.11.7 Unexpected delay on TD output

When SSC is configured with the following conditions:

- TCMR.STTDLY more than 0
- RCMR.START = Start on falling edge / Start on Rising edge / Start on any edge
- RFMR.FSOS = None (input)
- TCMR.START = Receive Start

An unexpected delay of 2 or 3 system clock cycles is added to TD output.

Problem Fix/Workaround

None.

41.12 TC**41.12.1 Wrong Compare at restart if burst low**

If the counter was stopped or disabled, unwanted Compare RA, RB or RC may occur at restart if the clock selected by the counter is masked by a low selected burst input when the trigger event is recognized at the selected clock active edge. All compare effects are affected, as the flags are set incorrectly and CPC trigger, CPC stop or CPC disable may occur.

Problem Fix/Workaround

None.

41.12.2 Wrong 0 captured before Compare RC trigger

A wrong 0 is captured in RA or RB during the last selected counter clock period if CPCTRG is active and the capture event occurred at least one Master Clock cycle after the last counter value update.

Problem Fix/Workaround

None.

41.12.3 Erroneous capture with burst low

The value captured is not equal to the Counter Value if the selected burst input is low at capture time, i.e., at the selected clock active edge where the capture event is recognized.

The captured value may be 0; otherwise, it is the Counter Value plus one instead of the Counter Value.

Problem Fix/Workaround

None.

41.12.4 **Bad capture at restart if burst low**

The captured value is not zero if burst is low when the preceding trigger event is recognized. Instead, the captured value is the Counter Value before the trigger.

Problem Fix/Workaround

None.

41.12.5 **TIOA and TIOB outputs stuck in case of simultaneous events**

In the register TC_CMCR, if at least one of the fields ASWTRG or AEEVT or ACPC is set to 0x0 (none), the event programmed by ACPA is not carried out.

In the register TC_CMCR, if at least one of the fields ASWTRG or AEEVT is set to 0x0 (none), the event programmed by ACPC is not carried out.

In the register TC_CMCR, if the field ASWTRG is set to 0x0 (none), the event programmed by AEEVT is not carried out.

The same problem exists on the TIOB output with the fields BSWTRG, BEEVT, BCPC and BCPB.

Problem Fix/Workaround

An order of priority for TIOA and/or TIOB events must be defined depending on the user application.

41.12.6 **TIMER_CLOCK2 not sampled on same edge as TIMER_CLOCK0 and TIMER_CLOCK1**

TIMER_CLOCK2/TIMER_CLOCK5 is sampled on the system clock falling edge of Master Clock, whereas TIMER_CLOCK0/TIMER_CLOCK3 and TIMER_CLOCK1/TIMER_CLOCK4 are sampled on the rising edge of Master Clock. This should not have any effect on the functional operations of the Timer Counter unless the Timer Counter is used at its speed limit.

Problem Fix/Workaround

None.

41.12.7 **Triggers do not clear the counter in Up/Down Mode**

When the field WAVESEL in TC_CMCR is at value 0x1 or 0x3, the triggers do not reset the counter value. The counter value can be reset only by modifying the field WAVESEL.

Problem Fix/Workaround

None.

41.12.8 **Triggers in Up/Down Mode are lost when burst signal is active**

When the field WAVESEL in TC_CMCR is at value 0x1 or 0x3, the triggers occurring while the selected burst signal is active (clock disabled) are not taken into account.

Problem Fix/Workaround

None.

41.12.9 **Clock Selection Limitation in Up/Down Mode**

Selecting the Master Clock or the Master Clock divided by 2 as the Timer Counter Clock may lead to unpredictable result when the field WAVESEL in TC_CMCR is at value 0x1 or 0x3.

Problem Fix/Workaround

None.

41.12.10 Spurious counter overflow in Up/Down Mode

When the field WAVESEL in TC_CMR is at value 0x1 or 0x3 and when the counter reaches the value 0xFFFF, it inverts its sense and decrements to 0xFFFE. At the same time, the OVF bit in TC_SR is set.

Problem Fix/Workaround

None.

41.13 TWI

41.13.1 Disabling Does not Operate Correctly

Any transfer in progress is immediately frozen if the Control Register (TWI_CR) is written with the bit MSDIS at 1. Furthermore, the status bits TXCOMP and TXRDY in the Status Register (TWI_SR) are not reset.

Problem Fix/Workaround

The user must wait for the end of transfer before disabling the TWI. In addition, the interrupts must be disabled before disabling the TWI.

41.13.2 NACK Status Bit Lost

During a master frame, if TWI_SR is read between the Non Acknowledge condition detection and the TXCOMP bit rising in the TWI_SR, the NACK bit is not set.

Problem Fix/Workaround

The user must wait for the TXCOMP status bit by interrupt and must not read the TWI_SR as long as transmission is not completed.

Note: TXCOMP and NACK fields are set simultaneously and the NACK field is reset after the read of the TWI_SR.

41.13.3 Possible Receive Holding Register Corruption

When loading the TWI_RHR, the transfer direction is ignored. The last data byte received in the TWI_RHR is corrupted at the end of the first subsequent transmit data byte. Neither RXRDY nor OVERRUN status bits are set if this occurs.

Problem Fix/Workaround

The user must be sure that received data is read before transmitting any new data.

41.13.4 Clock Divider

The value of $CLDIV \times 2^{CKDIV}$ must be less than or equal to 8191; the value of $CHDIV \times 2^{CKDIV}$ must be less than or equal to 8191.

Problem Fix/Workaround

None.

41.13.5 Software reset

When a software reset is performed during a frame and when TWCK is low, it is impossible to initiate a new transfer in READ or WRITE mode.

Problem Fix/Workaround

None.

41.13.6 TXCOMP and TXRDY reset

TXCOMP and TXRDY are not reset by MSDIS.

Problem Fix/Workaround

None.

41.13.7 Data lost on high latency

In case of high latency to process the RXRDY interrupt, with RXRDY set, if the receive data register is read at the same time as new data is captured into the register, the RXRDY flag is cleared and the new data is lost because the associated RXRDY is not set.

Problem Fix/Workaround

None.

41.14 USART

41.14.1 RTS0 not connected

Internally, the RTS0 signal of the USART0 is not connected to PA21.

Problem Fix/Workaround

The RTS0 signal of the USART0 is connected to the PIO Controller D. The PIOD can be used to control the RTS0 signal. The PIOD is only available in the AT91RM9200 BGA package.

41.14.2 US_IF must be initialized

US_IF must be initialized even in transmission mode.

Problem Fix/Workaround

None.

41.14.3 TXD signal is floating in Modem and Hardware Handshaking modes

The TXD signal should be pulled up in Modem and Hardware Handshaking modes.

Problem Fix/Workaround

TXD is multiplexed with PIO which integrates a pull-up resistor.

This internal pull-up needs to be enabled.

41.14.4 DCD is active High instead of Low

The DCD signal is active at 'High' level into the USART block (Modem mode).

DCD should be active at 'Low' level.

Problem Fix/Workaround

Add an inverter.

41.14.5 Bad value in Number of Errors Register

The Number of Errors Register always returns 0 instead of the ISO7816 error number.

Problem/Fix Workaround

None.

41.15 USB Host Port

41.15.1 No pulldown on port 2 using 208-lead PQFP package

The second port of the UHP is unbonded and there is no pull-down on DP and DM.

This may result in an unexpected connect detection on the second port.

Problem Fix/Workaround

A software workaround is to hardcode the NDP field of the HcRhDescriptorA operational register to 1.

42. Revision History

Revision History

Version A Publication Date: 22-Apr-03

Version B Publication Date: 22-Aug-03

Page	Version B Changes Since Last Issue
Page 36	New Figure 8, ARM920T Internal Functional Block Diagram.
Page 56	Corrected fields in CP15 Register 7 register table.
Page 62	Updated Figure 9, AT91RM9200 Debug and Test Block Diagram with corrected DTXD and DRXD signal names and transfer direction of signals TST0 - TST1 and NRST.
Page 85	Change signal name to NPCS0.
Page 86	Changes to Figure 15, Boot Program Algorithm Flow Diagram.
Page 87	Corrected BMS state to high during reset. Corrected address for internal ROM mapping.
Page 89	In Table 21 and text, corrected device names AT45DBxxx.
Page 91	Changes to Figure 20, Serial DataFlash Download.
Page 96	Updated Table 24 with new pins used and table note.
Page 108	Code change in section Description of the SvcXmodem Structure.
Page 109	Code change in Table 29: Xmodem Service, first table cell.
Page 110	Code change in section Using the Service.
Page 111	Code change in Table 30: DataFlash Service Methods, first table cell.
Page 116	Code change in Steps 1 and 2 in section Using the Service.
Page 233	Changed Table 58, I/O Line Description.
Page 245	In AIC Source Mode Register, corrected descriptions of bits PRIOR and SRCTYPE.
Page 255	Change number of programmable clocks to four. Correct oscillator speed to read 32.768 kHz.
Page 256	Updated section I/O Lines with new information on clocks.
Page 257	New PMC Block Diagram, Figure 117.
Page 258	Updated Processor Clock and Programmable Clock Outputs descriptions. Updated Clock Generator description.
Page 259	New Clock Generator Block Diagram, Figure 118. Section Slow Clock Oscillator Startup Time updated.
Page 261	Added section Main Oscillator Bypass.
Page 263	Updated section PLLB Divider by 2.
Page 264	In section Master Clock Controller, changed references to PLLB Output to PLLB Clock. New Figure 124: Master Clock Controller. In section Processor Clock Source, specified differences between ARM7-based and ARM9-based systems.
Page 265	Section Programmable Clock Output Controller updated to show change in number of programmable clocks.
Page 267	In Table 60: Clock Switching Timings (Worst Case), changed PLLA Output to PLLA Clock and PLLB Output to PLLB Clock.
Page 268	In Figure 125: Switch Master Clock from Slow Clock to PLLA Clock and in Figure 126: Switch Master Clock from Main Clock to Slow Clock, changed signal names and waveform labels.
Page 269	In Figure 127: Change PLLA Programming, changed signal names and labels. New Figure 128: Programmable Clock Output Programming.

Page	Version B Changes Since Last Issue (Continued)
Page 270	Changed register names in Table 61: PMC Register Mapping: PMC_MOR to CKGR_MOR, PMC_MCFR to CKGR_MCFR, PMC_PLLAR to CKGR_PLLAR and PCM_PLLBR to CKGR_PLLBR. Remove registers PMC_PCK4, PMC_PCK5, PMC_PCK6 and PMC_PCK7 (addresses 0x0050 to 0x005C).
Page 271	In register PMC_SCER, deleted bits PCK7 to PCK4, fields 15 to 12. All bit names updated to include "Enable". In UHP bit description, deleted reference to 12 MHz clock.
Page 272	In register PMC_SCDR, deleted bits PCK7 to PCK4, fields 15 to 12. All bit names updated to include "Disable". In UHP bit description, deleted reference to 12 MHz clock.
Page 273	In register PMC_SCSR, deleted bits PCK7 to PCK4, fields 15 to 12. All bit names updated to include "Status". In UHP bit description, corrected to read "USB Host Port".
Page 276	Changed register name to PMC Clock Generator Main Oscillator Register. MOSCEN bit description changed to include information on Main Clock signal and crystal connection. OSCOUNT bit description changed to remove multiplication factor for Slow Clock cycles.
Page 277	Changed register name to PMC Clock Generator Main Clock Frequency Register. Corrected in MAINRDY field description reference to MAINF.
Page 278	Changed register name to PMC Clock Generator PLL A Register. In OUTA and MULA bits, changed references to PLLA Output to PLL A Clock.
Page 279	Changed register name to PMC Clock Generator PLL B Register. In OUTB and MULB bits, changed references to PLLB Output to PLL B Clock. Changed bit description for USB_96M.
Page 280	In PMC_MCKR, new clock source selections specified for CSS. MDIV bit condition added.
Page 281	In PMC_PCK0 to PMC_PCK3, new clock source selections specified for CSS.
Page 282	In PMC_IER and PMC_IDR, bits PCK7RDY, PCK6RDY, PCK5RDY and PCK4RDY removed.
Page 283	In PMC_SR, bits PCK7RDY, PCK6RDY, PCK5RDY and PCK4RDY removed.
Page 284	In PMC_IMR, bits PCK7RDY, PCK6RDY, PCK5RDY and PCK4RDY removed.
Page 312	Added Note to Figure 135.
Page 331	In DBGU Chip ID Register, corrected NVPTYP field to 000 for ROM.
Page 343	In Table 67: PIO Register Mapping, PIO_OWSR access changed to read-only.
Page 358	In PIO_OWSR, access changed to read-only.
Page 368	Changed all references from CPHA to NCPHA. Updated Figures 159 and 160 for clarity.
Page 391	In CHDIV and CLDIV bit descriptions in register TWI_CWGR, corrected equations for calculation of SCL high and low periods. In CHDIV, CLDIV and CKDIV bit descriptions in register TWI_CWGR, SCL replaced by TWCK.
Page 452	Updated Figure 214, Transmit Frame Format in Continuous Mode. Updated Figure 215, Receive Frame Format in Continuous Mode.
Page 460	In register SSC_RFMR, new description of bit DATLEN.
Page 596	In Table 109, DC Characteristics, changed conditions for Static Current.
Page 598	New consumption figures in Table 113 and Table 114.
Page 599	In Table 115: 32 kHz Oscillator Characteristics, V_{DDOSC} defined in Startup Time conditions. In Table 116: Main Oscillator Characteristics, V_{DDPLL} defined in Startup Time conditions. In Table 117: Phase Lock Loop Characteristics, corrected errors in Pump current max/min values.
Page 601	In Table 120: Switching Characteristics in Full Speed, min/max values for Rise/Fall Time Matching added.
Page 614	In Table 125: SDRAMC Signals, changed min values for SDRAMC ₂₃ to SDRAMC ₂₈ .

(Note: Page numbers listed below do not correspond to the page numbers as they appear in the revised datasheet format.)

Page	Version C Changes Since Last Issue
Global	All reference to Fast Forcing removed.
Global	Peripheral Data Controller (PDC) changed to Peripheral DMA Controller (PDC)
Global	SmartMedia. NAND Flash coupled to all references to SmartMedia, to read as; NAND Flash/SmartMedia.
Global	Input voltage range for VDDIOM and VDDIOP is 3.0. CSR 05-012
Page 1	Features: USART Hardware Handshaking. Reference to Software Handshaking removed. CSR 04-066
Page 3	Figure 1: NWAIT pin added to block diagram. CSR 03-209
Page 14	Table 1: AT91RM9200 Pinout for 208-lead PQFP package, pins 28, 30, 37 and 39 names modified. CSR 03-244
Page 23	Table 7: Pin Description, ICE and JTAG description, "Internal Pullup" added to comments for all signals, except TDO. CSR 04-315
Page 24	Table 7: Pin Description, NWAIT pin added. CSR 03-209
Page 68	Figure 14: AMP Mictor Connector Orientation, correct illustration inserted. CSR 03-242
Page 89	Table 21: DataFlash Device, AT45DB2562 removed. CSR 03-221
Page 91	Figure 20: Serial DataFlash Download, Correct illustration inserted. CSR 04-404
Page 127	Internal Memory Area 0 and Table 35: 16-bit value given to Memory Area 0.
Page 137	Boot Mode Select: 16-bit value given to external boot memory. CSR 03-205
Page 139	Table 37: I/O Lines Description NWAIT signal relocated to SMC. CSR 03-209
Page 150	Table 39: EBI Pins and External Device Connections, Pin/Controller line A13 - A15 changed to A13-A14 and SDRAMC changed to A11- A12. Pin/Controller line A15 added. CSR 03-217
Page 191	SMC Chip Select Registers; figures cross-referenced to RWHOLD signal.
Page 226	EBI_CFGR Register: Warning added to bit #1. CSR 03-243
Page 245	Table 57: Register Mapping. PERIPH_PTSR offset changed to 0x124. CSR 04-188
Page 259	SRCTYPE Interrupt source type descriptions changed.
Page 260	Figure 119. Typical Slow Clock Oscillator Connection; GNDPLL changed to GNDOSC.
Page 261	Figure 121. Typical Crystal Connection; GNDPLL changed to GNDOSC.
Page 261	Main Oscillator Control: sentence corrected to read; "...counting down on Slow Clock from the OSCOUNT value. CSR 03-232
Page 278	Main Oscillator Bypass: XIN pin information changed. CSR 04-405
Page 279	PMC Clock Generator PLL A Register; Line added to CKGR_PLLA limitations. CSR 05-005
Page 279	PMC Clock Generator PLL B Register; Line added to CKGR_PLLB limitations. CSR 05-005
Page 289	Table 62: Register Mapping. ST_IMR Register is read-only. CSR 03-232
Page 295	Real Time Controller changed to Real Time Clock. CSR 04-020
Page 311 (Global)	Debug Unit (DBGU), ICE Access Prevention removed.
Page 320, 332	Debut Unit User Interface: Force NTRST Register removed.
Page 348	PIO. Pull-up Resistor Control. Value of resistor changed from approximately 100 kΩ to 10 kΩ
Page 351 (Global)	PIO. Change PIO_PDSR from Peripheral Data Status Register to Pin Data Status Register

Page	Version C Changes Since Last Issue (Continued)
Page 362	Master Mode Operations: Cross reference to SPI User interface clarified. CSR 04-406
Page 368	Table 69: SPI Bus Protocol Mode, NCPHA column corrected. CSR 04-239
Page 386	Figure 170. TWI Write in Master Mode. "Set the control register"; reference to slave removed.
Page 387	Figure 171. TWI Read in Master Mode. Set the control register"; reference to slave removed.
Page 399	Changes to definitions of abbreviations in TWI "Transmitting Data" figure drawings.
Page 404	TWI Master Mode Register. IADRSZ[9:8], change to first line.
Page 405	TWI Internal Address Register. Text added to IADR description.
Page 406	TWI Status Register. Change to TXCOMP bit. Reference to slave removed.
Page 408	Multi-drop Mode: PAR field setting changed. CSR 04-187
Page 415	Receive NACK Inhibit: "Moreover, if INACK is reset".....(replaces; if INACK is set) CSR 05-006
Page 419	RS485 Mode and Figure 196. Typical Connection to an RS485 bus; changed RTS signal information. CSR 03-190
Page 502	Table 94. Bus Topology; footnote added to Type column of Pin Number "2" row.
Page 503	Command/Response Operation: PWSEN bit power saving formula changed...dividing the MCI clock by $[(2^{PWSDIV})+1]$.
Page 512	MCI_MR: PSWSDIV bit power saving formula changed... MCI clock divided by $[(2^{PWSDIV})+1]$ when entering Power Saving Mode. CSR 05-009
Page 523	UDP: Overview, text changed.
Page 525	Main features of UDP changed. CSR 04-026
Page 526	Figure 244. Board Schematic to Interface USB Device Peripheral. USB signals added to figure.
Page 528	Figure 244: Resistor level changed. CSR 04-025, CSR 04-116
Page 544 & 560	UDP User Interface: Transceiver Control Register (USB_TXVC) added.
Page 567	Power Management: Steps to put EMAC in Local Loopback Mode added. CSR 05-014
Page 594	Table 109: V_{DDIOM} and V_{DDIOP} DC Supply Characteristics, Max changed to 3.6. CSR 04-076 V_{DDIOM} and V_{DDIOP} DC Supply Characteristics, Min changed to 3.0 I_{SC} Condition changed to On $V_{DDcore} = 1.95V$
Page 596	Power Consumption: added; • EMAC 50MHz clock not connected Table 113: Power Consumption for PMC Modes, and Table 114: Power Consumption by Peripheral, Consumption values changed. CSR 03-234 Table 114: Power Consumption by Peripheral. Note added to EMAC line
Page 597	Table 117: Phase Lock Loop Characteristics, changes to "F _{OUT} " line. The "K ₀ " and "I _p " lines have been eliminated. CSR 04-234, CSR 04-006
Page 604 - 605	Temperature Derating Factor: Figures 266, 267 and 268; derating curves changed. CSR 05-013
Page 626-629	Package Drawings: Tables 136 - 141 added, figure 278; 256-ball BGA package drawing changed.
Page 630-631	Soldering Profiles: Tables 142 - 143 added for Standard package and table 144 for Green and RoHS-compliant package.
Page 633	Table 145; Ordering Information. New information added.

Version D

Publication Date: 11-Jul-05

Page	Change	CSR Ref.
25	In Table 4-7, "Pin Description List," on page 25 added mention of Schmitt trigger for pins JTAGSEL, TDI, TCK, TMS, NTRST, TST0, TST1 AND NRST.	05-348
140	Changed use of NWR1 for 8-bit static device in Table 17-3, "EBI Pins and External Device Connections" from WE to "-".	-
217 218	Removed Flash device references in Figure 20-2 in " Burst Flash Controller (BFC) " . Removed Section 20.5.1 "I/O Lines" on page 218.	05-122
342	In " SRAMSIZ: Internal SRAM Size " bit description in " Debug Unit (DBGU) " , changed Size from "Reserved" to "80K bytes".	05-115
348	New information on value of internal pull-ups in " Pull-up Resistor Control " , Section 21.4.1 .	05-352
422	Corrected information on parity levels in " Universal Synchronous Asynchronous Receiver Transceiver (USART) " , Section 30.6.3.5 .	05-067
427	Corrected stop bit level in Figure 30-15 .	
437	Made all reset values hexadecimal in Table 30-12 on page 437.	05-181
All 570	In " USB Device Port (UDP) " , changed all register names to UDP_xxx. Replaced ENDBURST by ENDBUSRES in " USB Device Port (UDP) " , Section 34.5.3.1 and " UDP Interrupt Clear Register " .	05-147 05-148
586	Updated " ENDBUSRES: Clear End of Bus Reset Interrupt " bit description,	
596	Added information on memory access errors in " USB Host Port (UHP) " , Section 35.2 .	05-240
632	In Table 37-2 , changed min and max values for I _{PULL} and added new information on R _{PULLUP} .	05-352
633	Changed references from Master Clock to Processor Clock in Table 37-3, "Processor Clock Waveform Parameters," on page 633.	05-123
642 and following	In " AT91RM9200 AC Characteristics " , updated derating figures in Table 38-1 , Table 38-2 , Table 38-5 , Table 38-7 , Table 38-8 and Table 38-11 .	05-287
669	Updated ordering reference for PQFP208 Green package option in Table 40-1 .	

Revision History (cont.)

Document Version	Change	CSR Ref.
1768E	In "Features" on page 1, corrected power consumption values.	05-371
	In Section 23.6.7 "PMC Clock Generator Main Oscillator Register" on page 283, removed all references to OSCBYPASS.	05-450
	In Table 36-5, "EMAC Register Mapping," on page 612, update Statistics Registers with offset correction and new registers. In Table 36-6, "EMAC Statistic Register Block Register Descriptions," on page 629, update with new offset corrections and registers.	05-435
	Removed MTBF data from Section 39.1.1 "Thermal Data" on page 661.	05-453
	Included new Section 41. "AT91RM9200 Errata" on page 671 in datasheet. Formerly document 6015G.	
1768F	Reformatted Section 8. "Memories" on page 17. Inserted new figure Figure 8-1 on page 17 with overall product memory map.	
	Removed note in Table 17-3, "EBI Pins and External Device Connections," on page 137 giving information on ALE and CLE pins.	1730
	Added Section 17.7 "Implementation Examples" on page 147 with figures,	
	Removed Application Example from "Static Memory Controller (SMC)" . Removed Application Example from "SDRAM Controller (SDRAMC)" .	2663
	Revised and updated Section 33. "MultiMedia Card Interface (MCI)" on page 519.	2664
	Corrected errata: Updated Static Current Typ and Max values in Table 37-2, "DC Characteristics," on page 632; updated max PLL output frequency in Table 37-10, "Phase Lock Loop Characteristics," on page 636.	2516, 2517, 2525, 2608
	Renumbered and updated Section 41. "AT91RM9200 Errata" on page 671.	
Changed values in Table 39-12, "Soldering Profile," on page 666.	2492	
1768G	Updated "Features" and Section 4. "Package and Pinout" on page 8 with additional details on package options.	
	PMC: Updated capacitor details in Section 23.4.5.1 "Main Oscillator Connections" on page 266 and Section 23.4.5.5 "Main Oscillator Bypass" on page 267.	3339
	UDP: In Section 34.6.4 "UDP Interrupt Enable Register" on page 576, Section 34.6.5 "UDP Interrupt Disable Register" on page 578, Section 34.6.6 "UDP Interrupt Mask Register" on page 580, Section 34.6.7 "UDP Interrupt Status Register" on page 582 and Section 34.6.9 "UDP Reset Endpoint Register" on page 587, removed all references to Endpoint 6 and Endpoint 7 (bits and bit descriptions).	3203
	Updated Table 37-1, "Absolute Maximum Ratings*," on page 631.	3063
	Updated Input Capacitance value in Table 37-7, "XIN Clock Electrical Characteristics," on page 634.	3339
	Updated C _L , C _{L1} , C _{L2} values in Table 37-6, "Main Oscillator Characteristics," on page 634.	3287, 3339
	Updated Table 40-1, "Ordering Information," on page 669.	
	In "AT91RM9200 Errata" , added Section 41.1 "Marking" on page 671.	
1768H	Ordering code AT91RM9200-CI-002 removed from Section 40. "AT91RM9200 Ordering Information" on page 669	6423

Document Version	Change	CSR Ref.
1768I	USB Endpoint Size values edited in Table 34-1 on page 557	3481
	A Warning paragraph added to Section 34.6.10 “UDP Endpoint Control and Status Register” on page 588	3764
	LDR Opcode edited in Figure 13-3 on page 86	4453
	Sections 37.4 and 37.5 reversed, to have “Clock Characteristics” followed by “Crystal Oscillator Characteristics”	4666
	Section 41.14.3 “TXD signal is floating in Modem and Hardware Handshaking modes” on page 682 and Section 41.14.4 “DCD is active High instead of Low” on page 682 added to USART Errata	4723
	240 MHz value changed into 180 MHz in Section 23.4.3 “Clock Generator” on page 264	4923
	240 MHz value in OUTA and OUTB tables changed into 180 MHz in Section 23.6.9 “PMC Clock Generator PLL A Register” on page 285 and Section 23.6.10 “PMC Clock Generator PLL B Register” on page 286	4925
	Section 41.6.4 “OSCBYPASS is not functional with PLLA” on page 675 added to PMC Errata	4964
	USART3 0XFFEC000 changed into 0XFFFCC000 in Figure 8-1 on page 17	5067
	OSCBYPASS added, MOSCEN and OSCOUNT edited in Section 23.6.7 “PMC Clock Generator Main Oscillator Register” on page 283	5077
	2 rows added to Table 38-4 on page 649	5102
	Section 25.4.5 “Updating Time/Calendar” on page 307 edited	5113
	Standby conditions edited in Table 37-8 on page 635	5192
	A footnote added to USART “Overview” on page 411	5208
	Weight values changed in Table 39-4 on page 663 and Table 39-7 on page 664	5258
	2CKDIV changed into 2 ^{CKDIV} in Section 41.13.4 “Clock Divider” on page 681	5431
	Section 18. “Static Memory Controller (SMC)” on page 155 changed, using SMC_ABC (6153) Programmer Datasheet content	5618
	SDIO, SDIORQA and SDIORQB removed from Section 33.9 “MultiMedia Card Interface (MCI) User Interface” on page 533	5628
	NWDOVF removed from Figure 24-1 on page 293 and Figure 24-4 on page 295 . Section 24.4.3 Watchdog Overflow removed. EXTEN removed from Figure 24-4 on page 295 , from Section 24.5.3 “Watchdog Timer (WDT)” on page 295 , and from Section 24.6.3 “ST Watchdog Mode Register” on page 298	5683
	Main Oscillator Table 37-6 on page 634 edited, and 4 values (Driver Level, ESR, Shunt and Motionless Capacitance) added	6333
MCI erratum added: Section 41.4.11 “Data write operation and number of bytes” on page 674	6426	
- XIN Clock moved from “Clock Characteristics” to “Crystal Oscillator Characteristics” . - SSC erratum added: Section 41.11.7 “Unexpected delay on TD output” on page 679 - USART erratum added: Section 41.14.5 “Bad value in Number of Errors Register” on page 682 .	RFO	



Table of Contents

	Features	1
1	Description	2
2	Block Diagram	3
3	Signal Description	4
4	Package and Pinout	8
	4.1208-pin PQFP Package Outline	8
	4.2208-pin PQFP Package Pinout	9
	4.3256-ball BGA Package Outline	10
	4.4256-ball BGA Package Pinout	11
5	Power Considerations	13
	5.1 Power Supplies	13
	5.2 Power Consumption	13
6	I/O Considerations	13
	6.1 JTAG Port Pins	13
	6.2 Test Pin	13
	6.3 Reset Pin	13
	6.4 PIO Controller A, B, C and D Lines	14
7	Processor and Architecture	14
	7.1 ARM920T Processor	14
	7.2 Debug and Test	14
	7.3 Boot Program	15
	7.4 Embedded Software Services	15
	7.5 Memory Controller	15
8	Memories	17
	8.1 Embedded Memories	18
9	System Peripherals	19
	9.1 Reset Controller	19
	9.2 Advanced Interrupt Controller	19
	9.3 Power Management Controller	19
	9.4 Debug Unit	20
	9.5 PIO Controller	20

10	<i>User Peripherals</i>	21
10.1	User Interface	21
10.2	Peripheral Identifiers	21
10.3	Peripheral Multiplexing on PIO Lines	22
10.4	External Bus Interface	27
10.5	Static Memory Controller	27
10.6	SDRAM Controller	28
10.7	Burst Flash Controller	28
10.8	Peripheral DMA Controller (PDC)	29
10.9	System Timer	29
10.10	Real-time Clock	29
10.11	USB Host Port	29
10.12	USB Device Port	29
10.13	Ethernet MAC	29
10.14	Serial Peripheral Interface	30
10.15	Two-wire Interface	30
10.16	USART	30
10.17	Serial Synchronous Controller	31
10.18	Timer Counter	31
10.19	MultiMedia Card Interface	32
11	<i>ARM920T Processor Overview</i>	33
11.1	Overview	33
11.2	Block Diagram	35
11.3	ARM9TDMI Processor	36
11.4	CP15 Coprocessor	41
11.5	Memory Management Unit (MMU)	43
11.6	Caches, Write Buffers and Physical Address	44
11.7	ARM920T User Interface	46
12	<i>Debug and Test Features (DBG Test)</i>	59
12.1	Overview	59
12.2	Block Diagram	60
12.3	Application Examples	61
12.4	Test Environment	61
12.5	Debug and Test Pin Description	62
12.6	Functional Description	63

13	<i>Boot Program</i>	83
13.1	Overview	83
13.2	Flow Diagram	84
13.3	Bootloader	85
13.4	Boot Uploader	92
13.5	Hardware and Software Constraints	94
14	<i>Embedded Software Services</i>	95
14.1	Overview	95
14.2	Service Definition	95
14.3	Embedded Software Services	99
15	<i>AT91RM9200 Reset Controller</i>	117
15.1	Overview	117
16	<i>Memory Controller (MC)</i>	121
16.1	Overview	121
16.2	Block Diagram	122
16.3	Functional Description	123
16.4	User Interface	128
17	<i>External Bus Interface (EBI)</i>	133
17.1	Overview	133
17.2	Block Diagram	134
17.3	I/O Lines Description	135
17.4	Application Example	137
17.5	Product Dependencies	140
17.6	Functional Description	140
17.7	Implementation Examples	147
17.8	External Bus Interface (EBI) User Interface	151
18	<i>Static Memory Controller (SMC)</i>	155
18.1	Overview	155
18.2	Block Diagram	156
18.3	I/O Lines Description	157
18.4	Product Dependencies	158
18.5	Functional Description	158
18.6	Static Memory Controller (SMC) User Interface	190
19	<i>SDRAM Controller (SDRAMC)</i>	195

19.1	Overview	195
19.2	Block Diagram	196
19.3	I/O Lines Description	196
19.4	Software Interface	197
19.5	Product Dependencies	199
19.6	Functional Description	201
19.7	SDRAM Controller (SDRAMC) User Interface	207
20	<i>Burst Flash Controller (BFC)</i>	217
20.1	Overview	217
20.2	Block Diagram	218
20.3	I/O Lines Description	218
20.4	Application Example	219
20.5	Product Dependencies	220
20.6	Functional Description	220
20.7	Burst Flash Controller (BFC) User Interface	229
21	<i>Peripheral DMA Controller (PDC)</i>	231
21.1	Overview	231
21.2	Block Diagram	231
21.3	Functional Description	232
21.4	Peripheral DMA Controller (PDC) User Interface	234
22	<i>Advanced Interrupt Controller (AIC)</i>	241
22.1	Overview	241
22.2	Block Diagram	242
22.3	Application Block Diagram	242
22.4	AIC Detailed Block Diagram	242
22.5	I/O Line Description	243
22.6	Product Dependencies	243
22.7	Functional Description	244
22.8	Advanced Interrupt Controller (AIC) User Interface	253
23	<i>Power Management Controller (PMC)</i>	263
23.1	Overview	263
23.2	Product Dependencies	264
23.3	Block Diagram	265
23.4	Functional Description	266
23.5	Clock Switching Details	275

23.6	Power Management Controller (PMC) User Interface	278
24	System Timer (ST)	295
24.1	Overview	295
24.2	Block Diagram	295
24.3	Application Block Diagram	296
24.4	Product Dependencies	296
24.5	Functional Description	296
24.6	System Timer (ST) User Interface	298
25	Real Time Clock (RTC)	307
25.1	Overview	307
25.2	Block Diagram	307
25.3	Product Dependencies	307
25.4	Functional Description	308
25.5	Real Time Clock (RTC) User Interface	310
26	Debug Unit (DBGU)	323
26.1	Overview	323
26.2	Block Diagram	324
26.3	Product Dependencies	325
26.4	UART Operations	325
26.5	Debug Unit User Interface	332
27	Parallel Input/Output Controller (PIO)	347
27.1	Overview	347
27.2	Block Diagram	348
27.3	Product Dependencies	349
27.4	Functional Description	349
27.5	I/O Lines Programming Example	354
27.6	Parallel Input/Output Controller (PIO) User Interface	356
28	Serial Peripheral Interface (SPI)	373
28.1	Overview	373
28.2	Block Diagram	374
28.3	Application Block Diagram	375
28.4	Product Dependencies	376
28.5	Functional Description	376
28.6	Serial Peripheral Interface (SPI) User Interface	384

29	<i>Two-wire Interface (TWI)</i>	397
	29.1 Overview	397
	29.2 Block Diagram	397
	29.3 Application Block Diagram	397
	29.4 Product Dependencies	398
	29.5 Functional Description	398
	29.6 Two-wire Interface (TWI) User Interface	404
30	<i>Universal Synchronous Asynchronous Receiver Transceiver (USART)</i>	413
	30.1 Overview	413
	30.2 Block Diagram	414
	30.3 Application Block Diagram	415
	30.4 I/O Lines Description	415
	30.5 Product Dependencies	415
	30.6 Functional Description	416
	30.7 USART User Interface	439
31	<i>Serial Synchronous Controller (SSC)</i>	457
	31.1 Overview	457
	31.2 Block Diagram	458
	31.3 Application Block Diagram	458
	31.4 Pin Name List	459
	31.5 Product Dependencies	459
	31.6 Functional Description	459
	31.7 SSC Application Examples	468
	31.8 Serial Synchronous Controller (SSC) User Interface	471
32	<i>Timer Counter (TC)</i>	487
	32.1 Overview	487
	32.2 Block Diagram	488
	32.3 Pin Name List	489
	32.4 Product Dependencies	489
	32.5 Functional Description	489
	32.6 Waveform Operating Mode	494
	32.7 Timer Counter (TC) User Interface	502
33	<i>MultiMedia Card Interface (MCI)</i>	521
	33.1 Description	521

33.2	Block Diagram	522
33.3	Application Block Diagram	523
33.4	Pin Name List	523
33.5	Product Dependencies	524
33.6	Bus Topology	524
33.7	MultiMedia Card Operations	527
33.8	SD Card Operations	534
33.9	MultiMedia Card Interface (MCI) User Interface	535
34	<i>USB Device Port (UDP)</i>	555
34.1	Overview	555
34.2	Block Diagram	556
34.3	Product Dependencies	557
34.4	Typical Connection	558
34.5	Functional Description	559
34.6	USB Device Port (UDP) User Interface	574
35	<i>USB Host Port (UHP)</i>	595
35.1	Overview	595
35.2	Block Diagram	596
35.3	Product Dependencies	597
35.4	Functional Description	598
35.5	Typical Connection	600
36	<i>Ethernet MAC (EMAC)</i>	601
36.1	Overview	601
36.2	Block Diagram	602
36.3	Application Block Diagram	602
36.4	Product Dependencies	603
36.5	Functional Description	604
36.6	Ethernet MAC (EMAC) User Interface	612
37	<i>AT91RM9200 Electrical Characteristics</i>	631
37.1	Absolute Maximum Ratings	631
37.2	DC Characteristics	632
37.3	Clocks Characteristics	633
37.4	Power Consumption	634
37.5	Crystal Oscillators Characteristics	635
37.6	PLL Characteristics	635



37.7	Transceiver Characteristics	636
38	AT91RM9200 AC Characteristics	639
38.1	Applicable Conditions and Derating Data	639
38.2	EBI Timings	642
38.3	JTAG/ICE Timings	657
38.4	ETM Timings	660
39	AT91RM9200 Mechanical Characteristics	661
39.1	Thermal and Reliability Considerations	661
39.2	Package Drawings	662
39.3	Soldering Profiles	665
40	AT91RM9200 Ordering Information	669
41	AT91RM9200 Errata	671
41.1	Marking	671
41.2	EBI	672
41.3	EMAC	672
41.4	MCI	672
41.5	PIO	674
41.6	PMC	674
41.7	ROM Bootloader	675
41.8	SDRAMC	675
41.9	SMC	676
41.10	SPI	676
41.11	SSC	677
41.12	TC	678
41.13	TWI	680
41.14	USART	681
41.15	USB Host Port	681
42	Revision History	683
	Revision History (cont.).....	688
	Table of Contents.....	i



Headquarters

Atmel Corporation
2325 Orchard Parkway
San Jose, CA 95131
USA
Tel: 1(408) 441-0311
Fax: 1(408) 487-2600

International

Atmel Asia
Unit 1-5 & 16, 19/F
BEA Tower, Millennium City 5
418 Kwun Tong Road
Kwun Tong, Kowloon
Hong Kong
Tel: (852) 2245-6100
Fax: (852) 2722-1369

Atmel Europe
Le Krebs
8, Rue Jean-Pierre Timbaud
BP 309
78054 Saint-Quentin-en-
Yvelines Cedex
France
Tel: (33) 1-30-60-70-00
Fax: (33) 1-30-60-71-11

Atmel Japan
9F, Tonetsu Shinkawa Bldg.
1-24-8 Shinkawa
Chuo-ku, Tokyo 104-0033
Japan
Tel: (81) 3-3523-3551
Fax: (81) 3-3523-7581

Product Contact

Web Site
www.atmel.com
www.atmel.com/AT91SAM

Technical Support
[AT91SAM Support](mailto:AT91SAM_Support@atmel.com)
[Atmel technical support](mailto:Atmel_techincal_support@atmel.com)

Sales Contacts
www.atmel.com/contacts/

Literature Requests
www.atmel.com/literature

Disclaimer: The information in this document is provided in connection with Atmel products. No license, express or implied, by estoppel or otherwise, to any intellectual property right is granted by this document or in connection with the sale of Atmel products. **EXCEPT AS SET FORTH IN ATMEL'S TERMS AND CONDITIONS OF SALE LOCATED ON ATMEL'S WEB SITE, ATMEL ASSUMES NO LIABILITY WHATSOEVER AND DISCLAIMS ANY EXPRESS, IMPLIED OR STATUTORY WARRANTY RELATING TO ITS PRODUCTS INCLUDING, BUT NOT LIMITED TO, THE IMPLIED WARRANTY OF MERCHANTABILITY, FITNESS FOR A PARTICULAR PURPOSE, OR NON-INFRINGEMENT. IN NO EVENT SHALL ATMEL BE LIABLE FOR ANY DIRECT, INDIRECT, CONSEQUENTIAL, PUNITIVE, SPECIAL OR INCIDENTAL DAMAGES (INCLUDING, WITHOUT LIMITATION, DAMAGES FOR LOSS OF PROFITS, BUSINESS INTERRUPTION, OR LOSS OF INFORMATION) ARISING OUT OF THE USE OR INABILITY TO USE THIS DOCUMENT, EVEN IF ATMEL HAS BEEN ADVISED OF THE POSSIBILITY OF SUCH DAMAGES.** Atmel makes no representations or warranties with respect to the accuracy or completeness of the contents of this document and reserves the right to make changes to specifications and product descriptions at any time without notice. Atmel does not make any commitment to update the information contained herein. Unless specifically provided otherwise, Atmel products are not suitable for, and shall not be used in, automotive applications. Atmel's products are not intended, authorized, or warranted for use as components in applications intended to support or sustain life.



© 2009 Atmel Corporation. All rights reserved. Atmel®, Atmel logo and combinations thereof DataFlash® and others, are registered trademarks or trademarks of Atmel Corporation or its subsidiaries. ARM®, Thumb® and the ARMPowered® logo and others are registered trademarks or trademarks of ARM Limited. Other terms and product names may be the trademarks of others.

Mouser Electronics

Authorized Distributor

Click to View Pricing, Inventory, Delivery & Lifecycle Information:

[Atmel:](#)

[AT91RM9200-QU-002](#) [AT91RM9200-CJ-002](#)