

Features

- High Performance, Low Power 32-Bit Atmel® AVR® Microcontroller
 - Compact Single-cycle RISC Instruction Set Including DSP Instruction Set
 - Read-Modify-Write Instructions and Atomic Bit Manipulation
 - Performing up to 1.39 DMIPS / MHz
 - Up to 83 DMIPS Running at 60 MHz from Flash
 - Up to 46 DMIPS Running at 30 MHz from Flash
 - Memory Protection Unit
- Multi-hierarchy Bus System
 - High-Performance Data Transfers on Separate Buses for Increased Performance
 - 7 Peripheral DMA Channels Improves Speed for Peripheral Communication
- Internal High-Speed Flash
 - 512K Bytes, 256K Bytes, 128K Bytes, 64K Bytes Versions
 - Single Cycle Access up to 30 MHz
 - Prefetch Buffer Optimizing Instruction Execution at Maximum Speed
 - 4ms Page Programming Time and 8ms Full-Chip Erase Time
 - 100,000 Write Cycles, 15-year Data Retention Capability
 - Flash Security Locks and User Defined Configuration Area
- Internal High-Speed SRAM, Single-Cycle Access at Full Speed
 - 96K Bytes (512KB Flash), 32K Bytes (256KB and 128KB Flash), 16K Bytes (64KB Flash)
- Interrupt Controller
 - Autovectored Low Latency Interrupt Service with Programmable Priority
- System Functions
 - Power and Clock Manager Including Internal RC Clock and One 32KHz Oscillator
 - Two Multipurpose Oscillators and Two Phase-Lock-Loop (PLL) allowing Independent CPU Frequency from USB Frequency
 - Watchdog Timer, Real-Time Clock Timer
- Universal Serial Bus (USB)
 - Device 2.0 and Embedded Host Low Speed and Full Speed
 - Flexible End-Point Configuration and Management with Dedicated DMA Channels
 - On-chip Transceivers Including Pull-Ups
 - USB Wake Up from Sleep Functionality
- One Three-Channel 16-bit Timer/Counter (TC)
 - Three External Clock Inputs, PWM, Capture and Various Counting Capabilities
- One 7-Channel 20-bit Pulse Width Modulation Controller (PWM)
- Three Universal Synchronous/Asynchronous Receiver/Transmitters (USART)
 - Independent Baudrate Generator, Support for SPI, IrDA and ISO7816 interfaces
 - Support for Hardware Handshaking, RS485 Interfaces and Modem Line
- One Master/Slave Serial Peripheral Interfaces (SPI) with Chip Select Signals
- One Synchronous Serial Protocol Controller
 - Supports I²S and Generic Frame-Based Protocols
- One Master/Slave Two-Wire Interface (TWI), 400kbit/s I²C-compatible
- One 8-channel 10-bit Analog-To-Digital Converter, 384ks/s
- 16-bit Stereo Audio Bitstream DAC
 - Sample Rate Up to 50 KHz
- QTouch® Library Support
 - Capacitive Touch Buttons, Sliders, and Wheels
 - QTouch and QMatrix Acquisition



32-bit ATMEL AVR Microcontroller

AT32UC3B0512
AT32UC3B0256
AT32UC3B0128
AT32UC3B064
AT32UC3B1512
AT32UC3B1256
AT32UC3B1128
AT32UC3B164

32059L-01/2012



- **On-Chip Debug System (JTAG interface)**
 - **Nexus Class 2+, Runtime Control, Non-Intrusive Data and Program Trace**
- **64-pin TQFP/QFN (44 GPIO pins), 48-pin TQFP/QFN (28 GPIO pins)**
- **5V Input Tolerant I/Os, including 4 high-drive pins**
- **Single 3.3V Power Supply or Dual 1.8V-3.3V Power Supply**

1. Description

The AT32UC3B is a complete System-On-Chip microcontroller based on the AVR32 UC RISC processor running at frequencies up to 60 MHz. AVR32 UC is a high-performance 32-bit RISC microprocessor core, designed for cost-sensitive embedded applications, with particular emphasis on low power consumption, high code density and high performance.

The processor implements a Memory Protection Unit (MPU) and a fast and flexible interrupt controller for supporting modern operating systems and real-time operating systems.

Higher computation capability is achieved using a rich set of DSP instructions.

The AT32UC3B incorporates on-chip Flash and SRAM memories for secure and fast access.

The Peripheral Direct Memory Access controller enables data transfers between peripherals and memories without processor involvement. PDCA drastically reduces processing overhead when transferring continuous and large data streams between modules within the MCU.

The Power Manager improves design flexibility and security: the on-chip Brown-Out Detector monitors the power supply, the CPU runs from the on-chip RC oscillator or from one of external oscillator sources, a Real-Time Clock and its associated timer keeps track of the time.

The Timer/Counter includes three identical 16-bit timer/counter channels. Each channel can be independently programmed to perform frequency measurement, event counting, interval measurement, pulse generation, delay timing and pulse width modulation.

The PWM modules provides seven independent channels with many configuration options including polarity, edge alignment and waveform non overlap control. One PWM channel can trigger ADC conversions for more accurate close loop control implementations.

The AT32UC3B also features many communication interfaces for communication intensive applications. In addition to standard serial interfaces like USART, SPI or TWI, other interfaces like flexible Synchronous Serial Controller and USB are available. The USART supports different communication modes, like SPI mode.

The Synchronous Serial Controller provides easy access to serial communication protocols and audio standards like I²S, UART or SPI.

The Full-Speed USB 2.0 Device interface supports several USB Classes at the same time thanks to the rich End-Point configuration. The Embedded Host interface allows device like a USB Flash disk or a USB printer to be directly connected to the processor.

Atmel offers the QTouch library for embedding capacitive touch buttons, sliders, and wheels functionality into AVR microcontrollers. The patented charge-transfer signal acquisition offers robust sensing and included fully debounced reporting of touch keys and includes Adjacent Key Suppression[®] (AKS[®]) technology for unambiguous detection of key events. The easy-to-use QTouch Suite toolchain allows you to explore, develop, and debug your own touch applications.

AT32UC3B integrates a class 2+ Nexus 2.0 On-Chip Debug (OCD) System, with non-intrusive real-time trace, full-speed read/write memory access in addition to basic runtime control. The Nanotrace interface enables trace feature for JTAG-based debuggers.

2. Overview

2.1 Blockdiagram

Figure 2-1. Block diagram

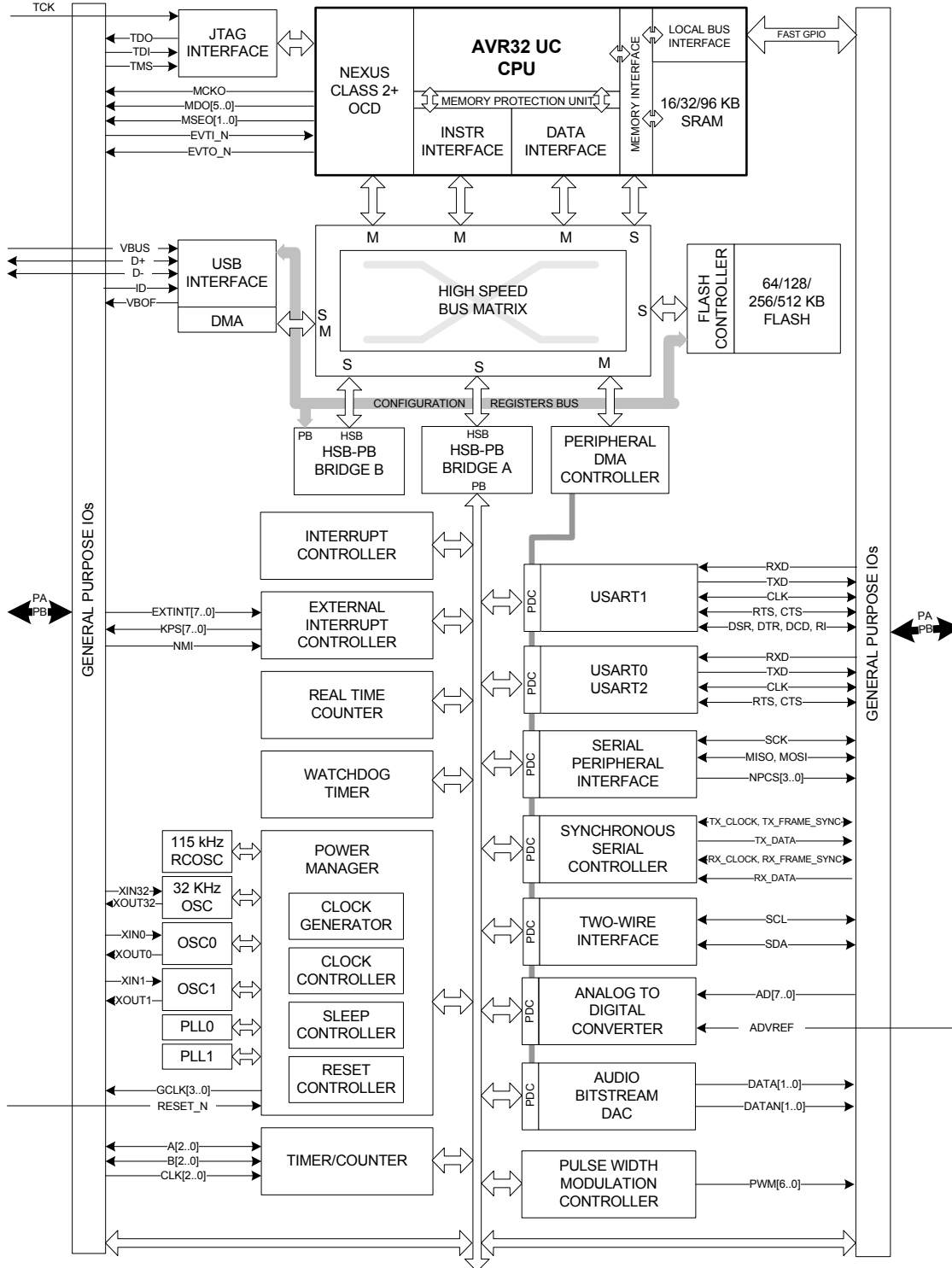

3. Configuration Summary

The table below lists all AT32UC3B memory and package configurations:

Table 3-1. Configuration Summary

| Feature | AT32UC3B0512 | AT32UC3B0256/128/64 | AT32UC3B1512 | AT32UC3B1256/128/64 |
|-------------------------------|--|---------------------|---------------|---------------------|
| Flash | 512 KB | 256/128/64 KB | 512 KB | 256/128/64 KB |
| SRAM | 96KB | 32/32/16KB | 96KB | 32/16/16KB |
| GPIO | 44 | | 28 | |
| External Interrupts | 8 | | 6 | |
| TWI | | | 1 | |
| USART | | | 3 | |
| Peripheral DMA Channels | | | 7 | |
| SPI | | | 1 | |
| Full Speed USB | Mini-Host + Device | | Device | |
| SSC | 1 | | 0 | |
| Audio Bitstream DAC | 1 | 0 | 1 | 0 |
| Timer/Counter Channels | | | 3 | |
| PWM Channels | | | 7 | |
| Watchdog Timer | | | 1 | |
| Real-Time Clock Timer | | | 1 | |
| Power Manager | | | 1 | |
| Oscillators | PLL 80-240 MHz (PLL0/PLL1) Crystal Oscillators 0.4-20 MHz (OSC0) Crystal Oscillator 32 KHz (OSC32K) RC Oscillator 115 kHz (RCSYS) | | | |
| | Crystal Oscillators 0.4-20 MHz (OSC1) | | | |
| 10-bit ADC number of channels | 8 | | 6 | |
| JTAG | | | 1 | |
| Max Frequency | | | 60 MHz | |
| Package | TQFP64, QFN64 | | TQFP48, QFN48 | |

4. Package and Pinout

4.1 Package

The device pins are multiplexed with peripheral functions as described in the Peripheral Multiplexing on I/O Line section.

Figure 4-1. TQFP64 / QFN64 Pinout

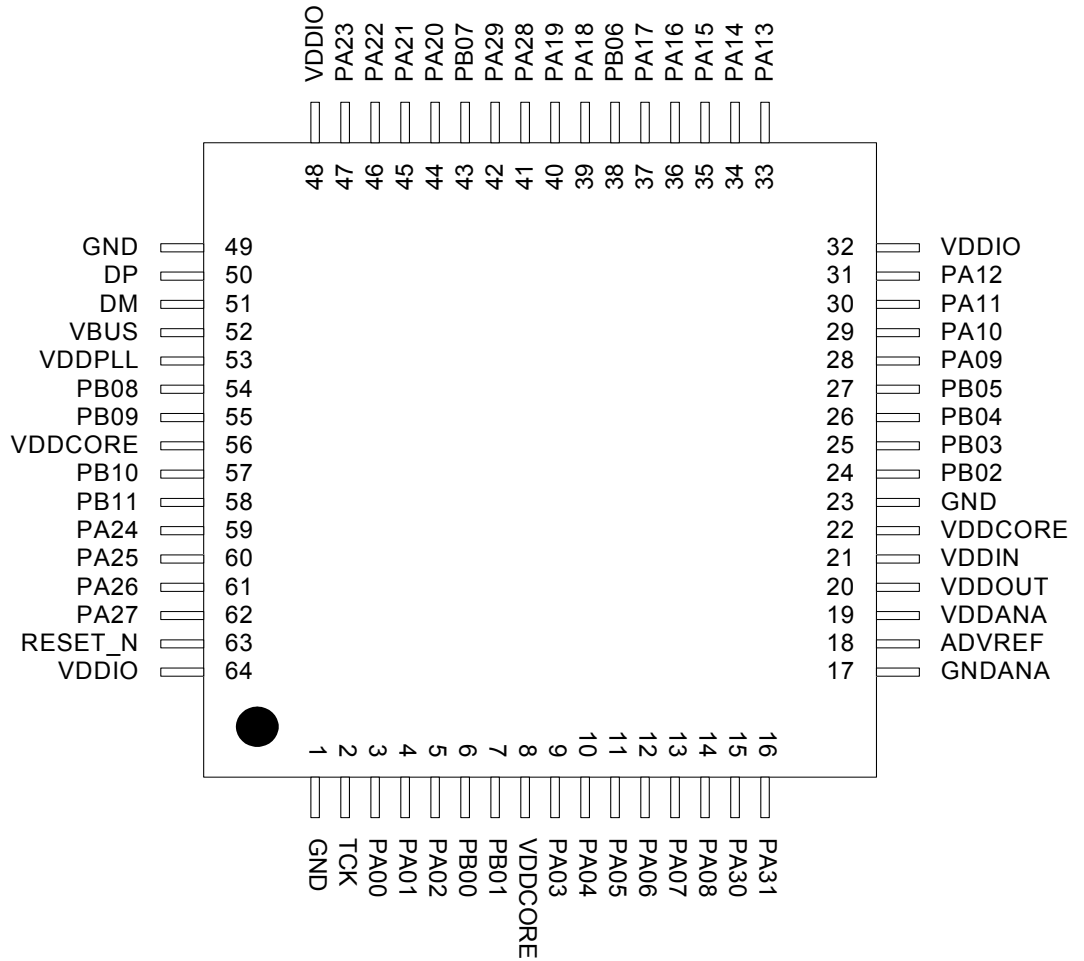
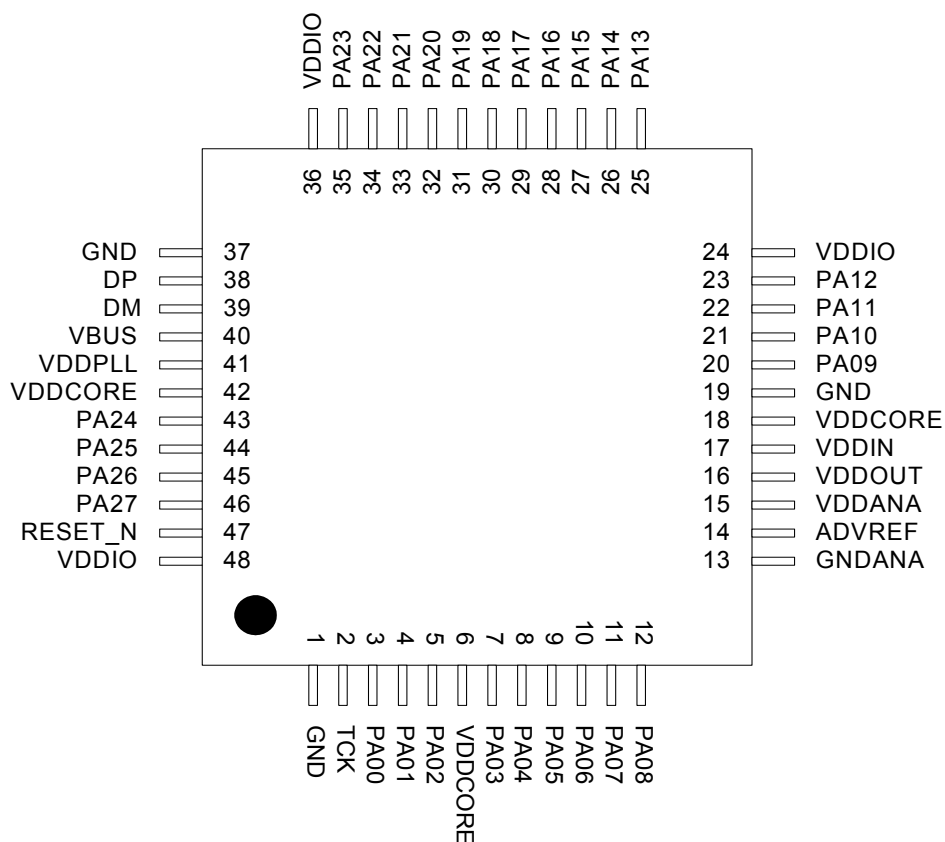

Figure 4-2. TQFP48 / QFN48 Pinout



Note: The exposed pad is not connected to anything internally, but should be soldered to ground to increase board level reliability.

4.2 Peripheral Multiplexing on I/O lines

4.2.1 Multiplexed signals

Each GPIO line can be assigned to one of 4 peripheral functions; A, B, C or D (D is only available for UC3Bx512 parts). The following table define how the I/O lines on the peripherals A, B, C or D are multiplexed by the GPIO.

Table 4-1. GPIO Controller Function Multiplexing

| 48-pin | 64-pin | PIN | GPIO Pin | Function A | Function B | Function C | Function D (only for UC3Bx512) |
|--------|--------|------|----------|-----------------|--------------|-----------------|-----------------------------------|
| 3 | 3 | PA00 | GPIO 0 | | | | |
| 4 | 4 | PA01 | GPIO 1 | | | | |
| 5 | 5 | PA02 | GPIO 2 | | | | |
| 7 | 9 | PA03 | GPIO 3 | ADC - AD[0] | PM - GCLK[0] | USBB - USB_ID | ABDAC - DATA[0] |
| 8 | 10 | PA04 | GPIO 4 | ADC - AD[1] | PM - GCLK[1] | USBB - USB_VBOF | ABDAC - DATAN[0] |
| 9 | 11 | PA05 | GPIO 5 | EIC - EXTINT[0] | ADC - AD[2] | USART1 - DCD | ABDAC - DATA[1] |

Table 4-1. GPIO Controller Function Multiplexing

| | | | | | | | |
|----|----|------|---------|---------------------|----------------|-----------------|---------------------|
| 10 | 12 | PA06 | GPIO 6 | EIC - EXTINT[1] | ADC - AD[3] | USART1 - DSR | ABDAC - DATAN[1] |
| 11 | 13 | PA07 | GPIO 7 | PWM - PWM[0] | ADC - AD[4] | USART1 - DTR | SSC - RX_FRAME_SYNC |
| 12 | 14 | PA08 | GPIO 8 | PWM - PWM[1] | ADC - AD[5] | USART1 - RI | SSC - RX_CLOCK |
| 20 | 28 | PA09 | GPIO 9 | TWI - SCL | SPI0 - NPCS[2] | USART1 - CTS | |
| 21 | 29 | PA10 | GPIO 10 | TWI - SDA | SPI0 - NPCS[3] | USART1 - RTS | |
| 22 | 30 | PA11 | GPIO 11 | USART0 - RTS | TC - A2 | PWM - PWM[0] | SSC - RX_DATA |
| 23 | 31 | PA12 | GPIO 12 | USART0 - CTS | TC - B2 | PWM - PWM[1] | USART1 - TXD |
| 25 | 33 | PA13 | GPIO 13 | EIC - NMI | PWM - PWM[2] | USART0 - CLK | SSC - RX_CLOCK |
| 26 | 34 | PA14 | GPIO 14 | SPI0 - MOSI | PWM - PWM[3] | EIC - EXTINT[2] | PM - GCLK[2] |
| 27 | 35 | PA15 | GPIO 15 | SPI0 - SCK | PWM - PWM[4] | USART2 - CLK | |
| 28 | 36 | PA16 | GPIO 16 | SPI0 - NPCS[0] | TC - CLK1 | PWM - PWM[4] | |
| 29 | 37 | PA17 | GPIO 17 | SPI0 - NPCS[1] | TC - CLK2 | SPI0 - SCK | USART1 - RXD |
| 30 | 39 | PA18 | GPIO 18 | USART0 - RXD | PWM - PWM[5] | SPI0 - MISO | SSC - RX_FRAME_SYNC |
| 31 | 40 | PA19 | GPIO 19 | USART0 - TXD | PWM - PWM[6] | SPI0 - MOSI | SSC - TX_CLOCK |
| 32 | 44 | PA20 | GPIO 20 | USART1 - CLK | TC - CLK0 | USART2 - RXD | SSC - TX_DATA |
| 33 | 45 | PA21 | GPIO 21 | PWM - PWM[2] | TC - A1 | USART2 - TXD | SSC - TX_FRAME_SYNC |
| 34 | 46 | PA22 | GPIO 22 | PWM - PWM[6] | TC - B1 | ADC - TRIGGER | ABDAC - DATA[0] |
| 35 | 47 | PA23 | GPIO 23 | USART1 - TXD | SPI0 - NPCS[1] | EIC - EXTINT[3] | PWM - PWM[0] |
| 43 | 59 | PA24 | GPIO 24 | USART1 - RXD | SPI0 - NPCS[0] | EIC - EXTINT[4] | PWM - PWM[1] |
| 44 | 60 | PA25 | GPIO 25 | SPI0 - MISO | PWM - PWM[3] | EIC - EXTINT[5] | |
| 45 | 61 | PA26 | GPIO 26 | USBB - USB_ID | USART2 - TXD | TC - A0 | ABDAC - DATA[1] |
| 46 | 62 | PA27 | GPIO 27 | USBB - USB_VBOF | USART2 - RXD | TC - B0 | ABDAC - DATAN[1] |
| | 41 | PA28 | GPIO 28 | USART0 - CLK | PWM - PWM[4] | SPI0 - MISO | ABDAC - DATAN[0] |
| | 42 | PA29 | GPIO 29 | TC - CLK0 | TC - CLK1 | SPI0 - MOSI | |
| | 15 | PA30 | GPIO 30 | ADC - AD[6] | EIC - SCAN[0] | PM - GCLK[2] | |
| | 16 | PA31 | GPIO 31 | ADC - AD[7] | EIC - SCAN[1] | PWM - PWM[6] | |
| | 6 | PB00 | GPIO 32 | TC - A0 | EIC - SCAN[2] | USART2 - CTS | |
| | 7 | PB01 | GPIO 33 | TC - B0 | EIC - SCAN[3] | USART2 - RTS | |
| | 24 | PB02 | GPIO 34 | EIC - EXTINT[6] | TC - A1 | USART1 - TXD | |
| | 25 | PB03 | GPIO 35 | EIC - EXTINT[7] | TC - B1 | USART1 - RXD | |
| | 26 | PB04 | GPIO 36 | USART1 - CTS | SPI0 - NPCS[3] | TC - CLK2 | |
| | 27 | PB05 | GPIO 37 | USART1 - RTS | SPI0 - NPCS[2] | PWM - PWM[5] | |
| | 38 | PB06 | GPIO 38 | SSC - RX_CLOCK | USART1 - DCD | EIC - SCAN[4] | ABDAC - DATA[0] |
| | 43 | PB07 | GPIO 39 | SSC - RX_DATA | USART1 - DSR | EIC - SCAN[5] | ABDAC - DATAN[0] |
| | 54 | PB08 | GPIO 40 | SSC - RX_FRAME_SYNC | USART1 - DTR | EIC - SCAN[6] | ABDAC - DATA[1] |

Table 4-1. GPIO Controller Function Multiplexing

| | | | | | | | |
|--|----|------|---------|---------------------|-------------|---------------|------------------|
| | 55 | PB09 | GPIO 41 | SSC - TX_CLOCK | USART1 - RI | EIC - SCAN[7] | ABDAC - DATAN[1] |
| | 57 | PB10 | GPIO 42 | SSC - TX_DATA | TC - A2 | USART0 - RXD | |
| | 58 | PB11 | GPIO 43 | SSC - TX_FRAME_SYNC | TC - B2 | USART0 - TXD | |

4.2.2 JTAG Port Connections

If the JTAG is enabled, the JTAG will take control over a number of pins, irrespective of the I/O Controller configuration.

Table 4-2. JTAG Pinout

| 64QFP/QFN | 48QFP/QFN | Pin name | JTAG pin |
|-----------|-----------|----------|----------|
| 2 | 2 | TCK | TCK |
| 3 | 3 | PA00 | TDI |
| 4 | 4 | PA01 | TDO |
| 5 | 5 | PA02 | TMS |

4.2.3 Nexus OCD AUX port connections

If the OCD trace system is enabled, the trace system will take control over a number of pins, irrespective of the PIO configuration. Two different OCD trace pin mappings are possible, depending on the configuration of the OCD AXS register. For details, see the AVR32 UC Technical Reference Manual.

Table 4-3. Nexus OCD AUX port connections

| Pin | AXS=0 | AXS=1 |
|---------|-------|-------|
| EVTI_N | PB05 | PA14 |
| MDO[5] | PB04 | PA08 |
| MDO[4] | PB03 | PA07 |
| MDO[3] | PB02 | PA06 |
| MDO[2] | PB01 | PA05 |
| MDO[1] | PB00 | PA04 |
| MDO[0] | PA31 | PA03 |
| EVTO_N | PA15 | PA15 |
| MCKO | PA30 | PA13 |
| MSEO[1] | PB06 | PA09 |
| MSEO[0] | PB07 | PA10 |

4.2.4 Oscillator Pinout

The oscillators are not mapped to the normal A, B or C functions and their muxings are controlled by registers in the Power Manager (PM). Please refer to the power manager chapter for more information about this.

Table 4-4. Oscillator pinout

| QFP48 pin | QFP64 pin | Pad | Oscillator pin |
|-----------|-----------|------|----------------|
| 30 | 39 | PA18 | XIN0 |
| | 41 | PA28 | XIN1 |
| 22 | 30 | PA11 | XIN32 |
| 31 | 40 | PA19 | XOUT0 |
| | 42 | PA29 | XOUT1 |
| 23 | 31 | PA12 | XOUT32 |

4.3 High Drive Current GPIO

One of GPIOs can be used to drive twice current than other GPIO capability (see Electrical Characteristics section).

Table 4-5. High Drive Current GPIO

| GPIO Name |
|-----------|
| PA20 |
| PA21 |
| PA22 |
| PA23 |

5. Signals Description

The following table gives details on the signal name classified by peripheral.

Table 5-1. Signal Description List

| Signal Name | Function | Type | Active Level | Comments |
|--------------|--------------------------------|-------------|--------------|-----------------|
| Power | | | | |
| VDDPLL | PLL Power Supply | Power Input | | 1.65V to 1.95 V |
| VDDCORE | Core Power Supply | Power Input | | 1.65V to 1.95 V |
| VDDIO | I/O Power Supply | Power Input | | 3.0V to 3.6V |
| VDDANA | Analog Power Supply | Power Input | | 3.0V to 3.6V |
| VDDIN | Voltage Regulator Input Supply | Power Input | | 3.0V to 3.6V |

Table 5-1. Signal Description List (Continued)

| Signal Name | Function | Type | Active Level | Comments |
|--|-------------------------------|--------------|--------------|-----------------|
| VDDOUT | Voltage Regulator Output | Power Output | | 1.65V to 1.95 V |
| GNDANA | Analog Ground | Ground | | |
| GND | Ground | Ground | | |
| Clocks, Oscillators, and PLL's | | | | |
| XIN0, XIN1, XIN32 | Crystal 0, 1, 32 Input | Analog | | |
| XOUT0, XOUT1, XOUT32 | Crystal 0, 1, 32 Output | Analog | | |
| JTAG | | | | |
| TCK | Test Clock | Input | | |
| TDI | Test Data In | Input | | |
| TDO | Test Data Out | Output | | |
| TMS | Test Mode Select | Input | | |
| Auxiliary Port - AUX | | | | |
| MCKO | Trace Data Output Clock | Output | | |
| MDO0 - MDO5 | Trace Data Output | Output | | |
| MSEO0 - MSEO1 | Trace Frame Control | Output | | |
| EVTI_N | Event In | Output | Low | |
| EVTO_N | Event Out | Output | Low | |
| Power Manager - PM | | | | |
| GCLK0 - GCLK2 | Generic Clock Pins | Output | | |
| RESET_N | Reset Pin | Input | Low | |
| External Interrupt Controller - EIC | | | | |
| EXTINT0 - EXTINT7 | External Interrupt Pins | Input | | |
| KPS0 - KPS7 | Keypad Scan Pins | Output | | |
| NMI | Non-Maskable Interrupt Pin | Input | Low | |
| General Purpose I/O pin- GPIOA, GPIOB | | | | |
| PA0 - PA31 | Parallel I/O Controller GPIOA | I/O | | |
| PB0 - PB11 | Parallel I/O Controller GPIOB | I/O | | |

Table 5-1. Signal Description List (Continued)

| Signal Name | Function | Type | Active Level | Comments |
|---|--------------------------------|--------|--------------|----------|
| Serial Peripheral Interface - SPI0 | | | | |
| MISO | Master In Slave Out | I/O | | |
| MOSI | Master Out Slave In | I/O | | |
| NPCS0 - NPCS3 | SPI Peripheral Chip Select | I/O | Low | |
| SCK | Clock | Output | | |
| Synchronous Serial Controller - SSC | | | | |
| RX_CLOCK | SSC Receive Clock | I/O | | |
| RX_DATA | SSC Receive Data | Input | | |
| RX_FRAME_SYNC | SSC Receive Frame Sync | I/O | | |
| TX_CLOCK | SSC Transmit Clock | I/O | | |
| TX_DATA | SSC Transmit Data | Output | | |
| TX_FRAME_SYNC | SSC Transmit Frame Sync | I/O | | |
| Timer/Counter - TIMER | | | | |
| A0 | Channel 0 Line A | I/O | | |
| A1 | Channel 1 Line A | I/O | | |
| A2 | Channel 2 Line A | I/O | | |
| B0 | Channel 0 Line B | I/O | | |
| B1 | Channel 1 Line B | I/O | | |
| B2 | Channel 2 Line B | I/O | | |
| CLK0 | Channel 0 External Clock Input | Input | | |
| CLK1 | Channel 1 External Clock Input | Input | | |
| CLK2 | Channel 2 External Clock Input | Input | | |
| Two-wire Interface - TWI | | | | |
| SCL | Serial Clock | I/O | | |
| SDA | Serial Data | I/O | | |
| Universal Synchronous Asynchronous Receiver Transmitter - USART0, USART1, USART2 | | | | |
| CLK | Clock | I/O | | |
| CTS | Clear To Send | Input | | |

Table 5-1. Signal Description List (Continued)

| Signal Name | Function | Type | Active Level | Comments |
|---|--|--------------|--------------|-------------|
| DCD | Data Carrier Detect | | | Only USART1 |
| DSR | Data Set Ready | | | Only USART1 |
| DTR | Data Terminal Ready | | | Only USART1 |
| RI | Ring Indicator | | | Only USART1 |
| RTS | Request To Send | Output | | |
| RXD | Receive Data | Input | | |
| TXD | Transmit Data | Output | | |
| Analog to Digital Converter - ADC | | | | |
| AD0 - AD7 | Analog input pins | Analog input | | |
| ADVREF | Analog positive reference voltage input | Analog input | | 2.6 to 3.6V |
| Audio Bitstream DAC - ABDAC | | | | |
| DATA0 - DATA1 | D/A Data out | Output | | |
| DATAN0 - DATAN1 | D/A Data inverted out | Output | | |
| Pulse Width Modulator - PWM | | | | |
| PWM0 - PWM6 | PWM Output Pins | Output | | |
| Universal Serial Bus Device - USBB | | | | |
| DDM | USB Device Port Data - | Analog | | |
| DDP | USB Device Port Data + | Analog | | |
| VBUS | USB VBUS Monitor and Embedded Host Negotiation | Analog Input | | |
| USBID | ID Pin of the USB Bus | Input | | |
| USB_VBOF | USB VBUS On/off: bus power control port | output | | |

5.1 JTAG pins

TMS and TDI pins have pull-up resistors. TDO pin is an output, driven at up to VDDIO, and has no pull-up resistor. These 3 pins can be used as GPIO-pins. At reset state, these pins are in GPIO mode.

TCK pin cannot be used as GPIO pin. JTAG interface is enabled when TCK pin is tied low.

5.2 RESET_N pin

The RESET_N pin is a schmitt input and integrates a permanent pull-up resistor to VDDIO. As the product integrates a power-on reset cell, the RESET_N pin can be left unconnected in case no reset from the system needs to be applied to the product.

5.3 TWI pins

When these pins are used for TWI, the pins are open-drain outputs with slew-rate limitation and inputs with inputs with spike-filtering. When used as GPIO-pins or used for other peripherals, the pins have the same characteristics as GPIO pins.

5.4 GPIO pins

All the I/O lines integrate a pull-up resistor. Programming of this pull-up resistor is performed independently for each I/O line through the GPIO Controllers. After reset, I/O lines default as inputs with pull-up resistors disabled, except when indicated otherwise in the column "Reset Value" of the GPIO Controller user interface table.

5.5 High drive pins

The four pins PA20, PA21, PA22, PA23 have high drive output capabilities.

5.6 Power Considerations

5.6.1 Power Supplies

The AT32UC3B has several types of power supply pins:

- **VDDIO: Powers I/O lines. Voltage is 3.3V nominal.**
- **VDDANA: Powers the ADC Voltage is 3.3V nominal.**
- **VDDIN: Input voltage for the voltage regulator. Voltage is 3.3V nominal.**
- **VDDCORE: Powers the core, memories, and peripherals. Voltage is 1.8V nominal.**
- **VDDPLL: Powers the PLL. Voltage is 1.8V nominal.**

The ground pins GND are common to VDDCORE, VDDIO and VDDPLL. The ground pin for VDDANA is GNDANA.

Refer to Electrical Characteristics section for power consumption on the various supply pins.

The main requirement for power supplies connection is to respect a star topology for all electrical connection.

Figure 5-1. Power Supply

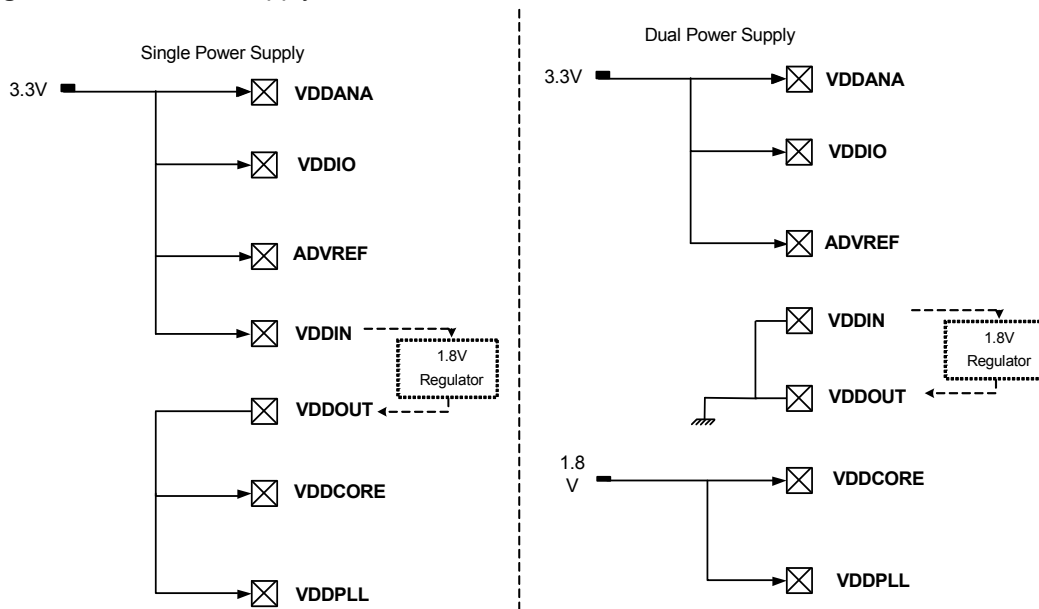

5.6.2 Voltage Regulator

5.6.2.1 Single Power Supply

The AT32UC3B embeds a voltage regulator that converts from 3.3V to 1.8V. The regulator takes its input voltage from VDDIN, and supplies the output voltage on VDDOUT that should be externally connected to the 1.8V domains.

Adequate input supply decoupling is mandatory for VDDIN in order to improve startup stability and reduce source voltage drop. Two input decoupling capacitors must be placed close to the chip.

Adequate output supply decoupling is mandatory for VDDOUT to reduce ripple and avoid oscillations. The best way to achieve this is to use two capacitors in parallel between VDDOUT and GND as close to the chip as possible

Figure 5-2. Supply Decoupling

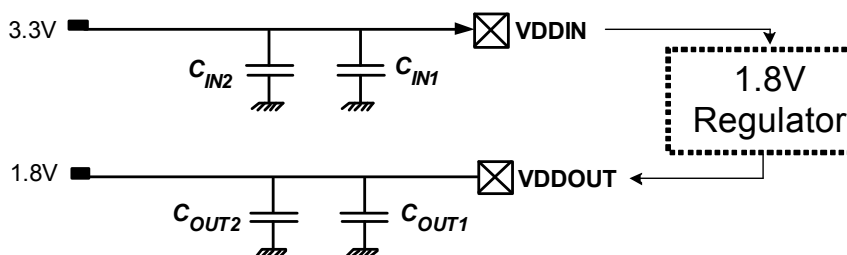

Refer to [Section 28.3 on page 610](#) for decoupling capacitors values and regulator characteristics.

For decoupling recommendations for VDDIO, VDDANA, VDDCORE and VDDPLL, please refer to the Schematic checklist.

5.6.2.2 Dual Power Supply

In case of dual power supply, VDDIN and VDDOUT should be connected to ground to prevent from leakage current.

To avoid over consumption during the power up sequence, VDDIO and VDDCORE voltage difference needs to stay in the range given [Figure 5-3](#).

Figure 5-3. VDDIO versus VDDCORE during power up sequence

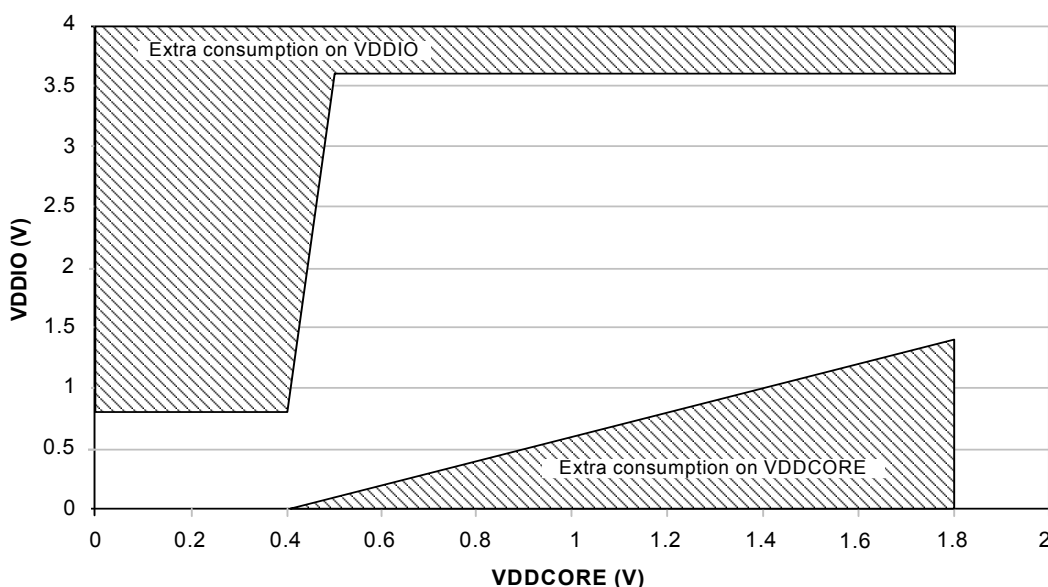

5.6.3 Analog-to-Digital Converter (ADC) reference.

The ADC reference (ADVREF) must be provided from an external source. Two decoupling capacitors must be used to insure proper decoupling.

Figure 5-4. ADVREF Decoupling

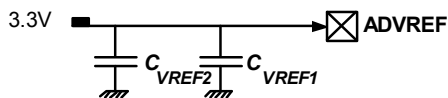

Refer to [Section 28.4 on page 610](#) for decoupling capacitors values and electrical characteristics.

In case ADC is not used, the ADVREF pin should be connected to GND to avoid extra consumption.

6. Processor and Architecture

Rev: 1.0.0.0

This chapter gives an overview of the AVR32UC CPU. AVR32UC is an implementation of the AVR32 architecture. A summary of the programming model, instruction set, and MPU is presented. For further details, see the *AVR32 Architecture Manual* and the *AVR32UC Technical Reference Manual*.

6.1 Features

- **32-bit load/store AVR32A RISC architecture**
 - 15 general-purpose 32-bit registers
 - 32-bit Stack Pointer, Program Counter and Link Register reside in register file
 - Fully orthogonal instruction set
 - Privileged and unprivileged modes enabling efficient and secure Operating Systems
 - Innovative instruction set together with variable instruction length ensuring industry leading code density
 - DSP extension with saturating arithmetic, and a wide variety of multiply instructions
- **3-stage pipeline allows one instruction per clock cycle for most instructions**
 - Byte, halfword, word and double word memory access
 - Multiple interrupt priority levels
- **MPU allows for operating systems with memory protection**

6.2 AVR32 Architecture

AVR32 is a high-performance 32-bit RISC microprocessor architecture, designed for cost-sensitive embedded applications, with particular emphasis on low power consumption and high code density. In addition, the instruction set architecture has been tuned to allow a variety of micro-architectures, enabling the AVR32 to be implemented as low-, mid-, or high-performance processors. AVR32 extends the AVR family into the world of 32- and 64-bit applications.

Through a quantitative approach, a large set of industry recognized benchmarks has been compiled and analyzed to achieve the best code density in its class. In addition to lowering the memory requirements, a compact code size also contributes to the core's low power characteristics. The processor supports byte and halfword data types without penalty in code size and performance.

Memory load and store operations are provided for byte, halfword, word, and double word data with automatic sign- or zero extension of halfword and byte data. The C-compiler is closely linked to the architecture and is able to exploit code optimization features, both for size and speed.

In order to reduce code size to a minimum, some instructions have multiple addressing modes. As an example, instructions with immediates often have a compact format with a smaller immediate, and an extended format with a larger immediate. In this way, the compiler is able to use the format giving the smallest code size.

Another feature of the instruction set is that frequently used instructions, like add, have a compact format with two operands as well as an extended format with three operands. The larger format increases performance, allowing an addition and a data move in the same instruction in a single cycle. Load and store instructions have several different formats in order to reduce code size and speed up execution.

The register file is organized as sixteen 32-bit registers and includes the Program Counter, the Link Register, and the Stack Pointer. In addition, register R12 is designed to hold return values from function calls and is used implicitly by some instructions.

6.3 The AVR32UC CPU

The AVR32UC CPU targets low- and medium-performance applications, and provides an advanced OCD system, no caches, and a Memory Protection Unit (MPU). Java acceleration hardware is not implemented.

AVR32UC provides three memory interfaces, one High Speed Bus master for instruction fetch, one High Speed Bus master for data access, and one High Speed Bus slave interface allowing other bus masters to access data RAMs internal to the CPU. Keeping data RAMs internal to the CPU allows fast access to the RAMs, reduces latency, and guarantees deterministic timing. Also, power consumption is reduced by not needing a full High Speed Bus access for memory accesses. A dedicated data RAM interface is provided for communicating with the internal data RAMs.

A local bus interface is provided for connecting the CPU to device-specific high-speed systems, such as floating-point units and fast GPIO ports. This local bus has to be enabled by writing the LOCEN bit in the CPUCR system register. The local bus is able to transfer data between the CPU and the local bus slave in a single clock cycle. The local bus has a dedicated memory range allocated to it, and data transfers are performed using regular load and store instructions. Details on which devices that are mapped into the local bus space is given in the Memories chapter of this data sheet.

[Figure 6-1 on page 19](#) displays the contents of AVR32UC.

Figure 6-1. Overview of the AVR32UC CPU

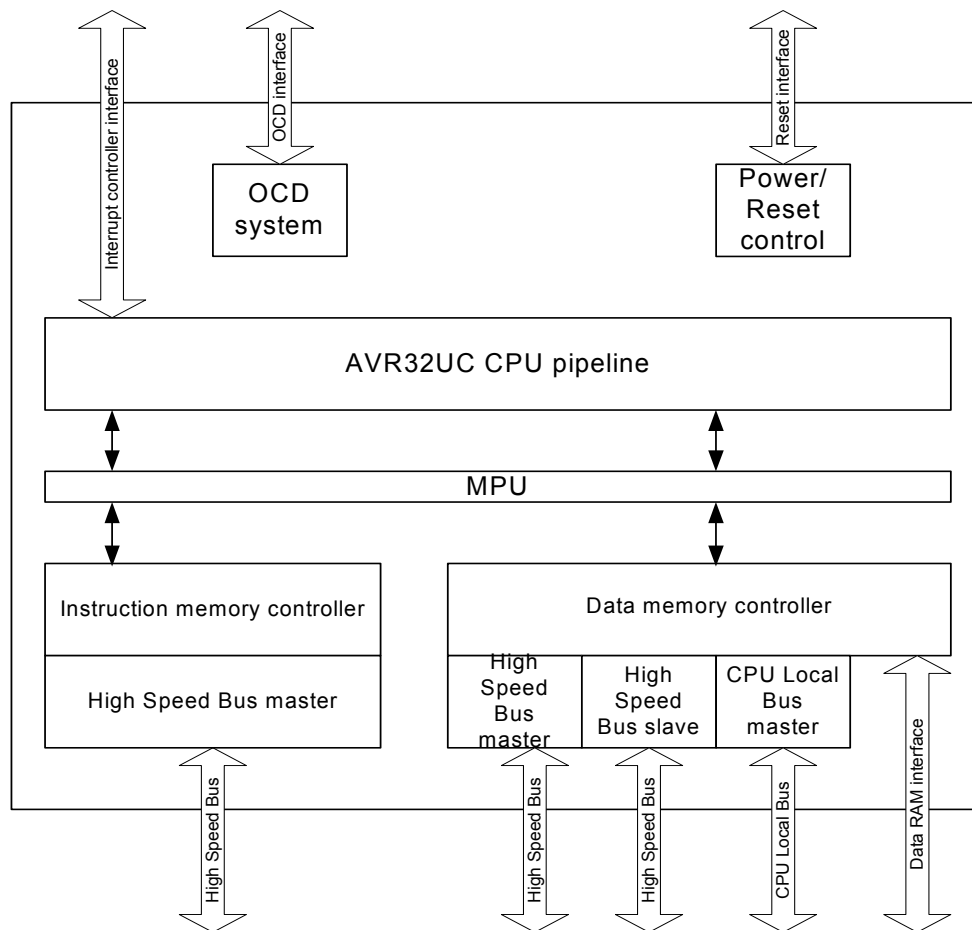

6.3.1 Pipeline Overview

AVR32UC has three pipeline stages, Instruction Fetch (IF), Instruction Decode (ID), and Instruction Execute (EX). The EX stage is split into three parallel subsections, one arithmetic/logic (ALU) section, one multiply (MUL) section, and one load/store (LS) section.

Instructions are issued and complete in order. Certain operations require several clock cycles to complete, and in this case, the instruction resides in the ID and EX stages for the required number of clock cycles. Since there is only three pipeline stages, no internal data forwarding is required, and no data dependencies can arise in the pipeline.

Figure 6-2 on page 20 shows an overview of the AVR32UC pipeline stages.

Figure 6-2. The AVR32UC Pipeline

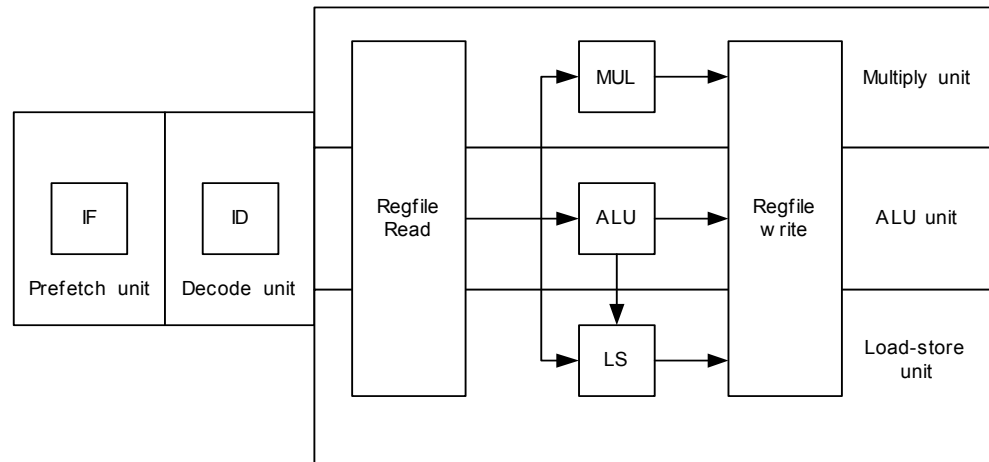

6.3.2 AVR32A Microarchitecture Compliance

AVR32UC implements an AVR32A microarchitecture. The AVR32A microarchitecture is targeted at cost-sensitive, lower-end applications like smaller microcontrollers. This microarchitecture does not provide dedicated hardware registers for shadowing of register file registers in interrupt contexts. Additionally, it does not provide hardware registers for the return address registers and return status registers. Instead, all this information is stored on the system stack. This saves chip area at the expense of slower interrupt handling.

Upon interrupt initiation, registers R8-R12 are automatically pushed to the system stack. These registers are pushed regardless of the priority level of the pending interrupt. The return address and status register are also automatically pushed to stack. The interrupt handler can therefore use R8-R12 freely. Upon interrupt completion, the old R8-R12 registers and status register are restored, and execution continues at the return address stored popped from stack.

The stack is also used to store the status register and return address for exceptions and *scall*. Executing the *rete* or *rets* instruction at the completion of an exception or system call will pop this status register and continue execution at the popped return address.

6.3.3 Java Support

AVR32UC does not provide Java hardware acceleration.

6.3.4 Memory Protection

The MPU allows the user to check all memory accesses for privilege violations. If an access is attempted to an illegal memory address, the access is aborted and an exception is taken. The MPU in AVR32UC is specified in the AVR32UC Technical Reference manual.

6.3.5 Unaligned Reference Handling

AVR32UC does not support unaligned accesses, except for doubleword accesses. AVR32UC is able to perform word-aligned *st.d* and *ld.d*. Any other unaligned memory access will cause an address exception. Doubleword-sized accesses with word-aligned pointers will automatically be performed as two word-sized accesses.

The following table shows the instructions with support for unaligned addresses. All other instructions require aligned addresses.

Table 6-1. Instructions with Unaligned Reference Support

| Instruction | Supported alignment |
|-------------|---------------------|
| ld.d | Word |
| st.d | Word |

6.3.6 Unimplemented Instructions

The following instructions are unimplemented in AVR32UC, and will cause an Unimplemented Instruction Exception if executed:

- All SIMD instructions
- All coprocessor instructions if no coprocessors are present
- retj, incjosp, popjc, pushjc
- tlbr, tlbs, tlbw
- cache

6.3.7 CPU and Architecture Revision

Three major revisions of the AVR32UC CPU currently exist.

The Architecture Revision field in the CONFIG0 system register identifies which architecture revision is implemented in a specific device.

AVR32UC CPU revision 3 is fully backward-compatible with revisions 1 and 2, ie. code compiled for revision 1 or 2 is binary-compatible with revision 3 CPUs.

6.4 Programming Model

6.4.1 Register File Configuration

The AVR32UC register file is shown below.

Figure 6-3. The AVR32UC Register File

| Application | | Supervisor | | INT0 | | INT1 | | INT2 | | INT3 | | Exception | | NMI | | Secure | |
|-------------|--------|------------|--------|--------|--------|--------|--------|--------|--------|--------|--------|-----------|--------|--------|--------|--------|--------|
| Bit 31 | Bit 0 | Bit 31 | Bit 0 | Bit 31 | Bit 0 | Bit 31 | Bit 0 | Bit 31 | Bit 0 | Bit 31 | Bit 0 | Bit 31 | Bit 0 | Bit 31 | Bit 0 | Bit 31 | Bit 0 |
| PC | PC | PC | PC | PC | PC | PC | PC | PC | PC | PC | PC | PC | PC | PC | PC | PC | PC |
| LR | LR | LR | LR | LR | LR | LR | LR | LR | LR | LR | LR | LR | LR | LR | LR | LR | LR |
| SP_APP | SP_SYS | SP_SYS | SP_SYS | SP_SYS | SP_SYS | SP_SYS | SP_SYS | SP_SYS | SP_SYS | SP_SYS | SP_SYS | SP_SYS | SP_SYS | SP_SYS | SP_SYS | SP_SEC | SP_SEC |
| R12 | R12 | R12 | R12 | R12 | R12 | R12 | R12 | R12 | R12 | R12 | R12 | R12 | R12 | R12 | R12 | R12 | R12 |
| R11 | R11 | R11 | R11 | R11 | R11 | R11 | R11 | R11 | R11 | R11 | R11 | R11 | R11 | R11 | R11 | R11 | R11 |
| R10 | R10 | R10 | R10 | R10 | R10 | R10 | R10 | R10 | R10 | R10 | R10 | R10 | R10 | R10 | R10 | R10 | R10 |
| R9 | R9 | R9 | R9 | R9 | R9 | R9 | R9 | R9 | R9 | R9 | R9 | R9 | R9 | R9 | R9 | R9 | R9 |
| R8 | R8 | R8 | R8 | R8 | R8 | R8 | R8 | R8 | R8 | R8 | R8 | R8 | R8 | R8 | R8 | R8 | R8 |
| R7 | R7 | R7 | R7 | R7 | R7 | R7 | R7 | R7 | R7 | R7 | R7 | R7 | R7 | R7 | R7 | R7 | R7 |
| R6 | R6 | R6 | R6 | R6 | R6 | R6 | R6 | R6 | R6 | R6 | R6 | R6 | R6 | R6 | R6 | R6 | R6 |
| R5 | R5 | R5 | R5 | R5 | R5 | R5 | R5 | R5 | R5 | R5 | R5 | R5 | R5 | R5 | R5 | R5 | R5 |
| R4 | R4 | R4 | R4 | R4 | R4 | R4 | R4 | R4 | R4 | R4 | R4 | R4 | R4 | R4 | R4 | R4 | R4 |
| R3 | R3 | R3 | R3 | R3 | R3 | R3 | R3 | R3 | R3 | R3 | R3 | R3 | R3 | R3 | R3 | R3 | R3 |
| R2 | R2 | R2 | R2 | R2 | R2 | R2 | R2 | R2 | R2 | R2 | R2 | R2 | R2 | R2 | R2 | R2 | R2 |
| R1 | R1 | R1 | R1 | R1 | R1 | R1 | R1 | R1 | R1 | R1 | R1 | R1 | R1 | R1 | R1 | R1 | R1 |
| R0 | R0 | R0 | R0 | R0 | R0 | R0 | R0 | R0 | R0 | R0 | R0 | R0 | R0 | R0 | R0 | R0 | R0 |
| SR | SR | SR | SR | SR | SR | SR | SR | SR | SR | SR | SR | SR | SR | SR | SR | SR | SR |

| |
|-----------|
| SS_STATUS |
| SS_ADRF |
| SS_ADDR |
| SS_ADR0 |
| SS_ADR1 |
| SS_SP_SYS |
| SS_SP_APP |
| SS_RAR |
| SS_RSR |

6.4.2 Status Register Configuration

The Status Register (SR) is split into two halfwords, one upper and one lower, see [Figure 6-4 on page 22](#) and [Figure 6-5 on page 23](#). The lower word contains the C, Z, N, V, and Q condition code flags and the R, T, and L bits, while the upper halfword contains information about the mode and state the processor executes in. Refer to the *AVR32 Architecture Manual* for details.

Figure 6-4. The Status Register High Halfword

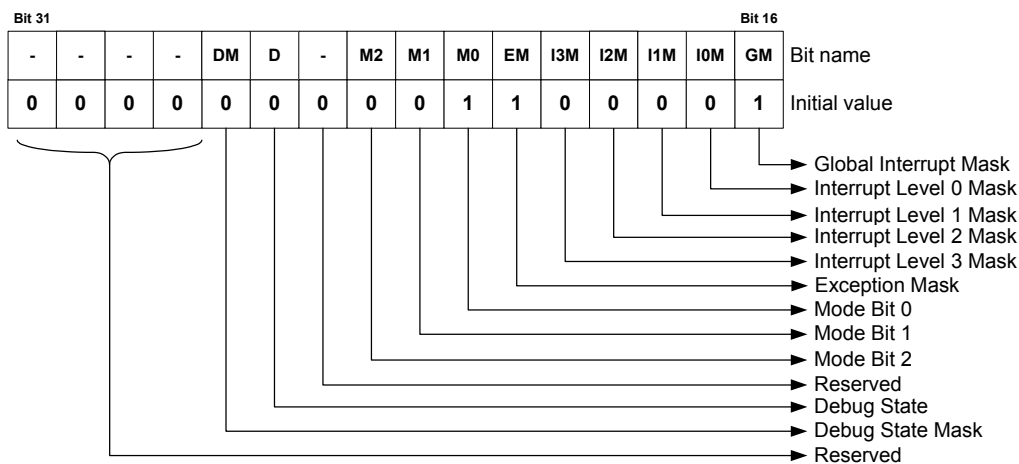
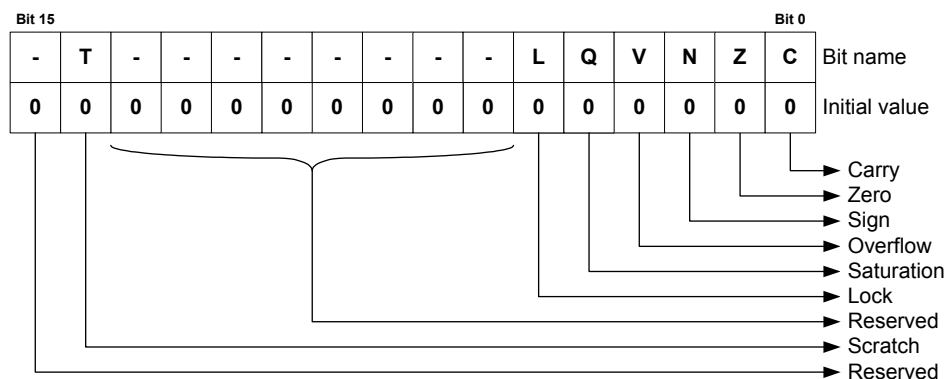

Figure 6-5. The Status Register Low Halfword



6.4.3 Processor States

6.4.3.1 Normal RISC State

The AVR32 processor supports several different execution contexts as shown in [Table 6-2 on page 23](#).

Table 6-2. Overview of Execution Modes, their Priorities and Privilege Levels.

| Priority | Mode | Security | Description |
|----------|------------------------|--------------|---|
| 1 | Non Maskable Interrupt | Privileged | Non Maskable high priority interrupt mode |
| 2 | Exception | Privileged | Execute exceptions |
| 3 | Interrupt 3 | Privileged | General purpose interrupt mode |
| 4 | Interrupt 2 | Privileged | General purpose interrupt mode |
| 5 | Interrupt 1 | Privileged | General purpose interrupt mode |
| 6 | Interrupt 0 | Privileged | General purpose interrupt mode |
| N/A | Supervisor | Privileged | Runs supervisor calls |
| N/A | Application | Unprivileged | Normal program execution mode |

Mode changes can be made under software control, or can be caused by external interrupts or exception processing. A mode can be interrupted by a higher priority mode, but never by one with lower priority. Nested exceptions can be supported with a minimal software overhead.

When running an operating system on the AVR32, user processes will typically execute in the application mode. The programs executed in this mode are restricted from executing certain instructions. Furthermore, most system registers together with the upper halfword of the status register cannot be accessed. Protected memory areas are also not available. All other operating modes are privileged and are collectively called System Modes. They have full access to all privileged and unprivileged resources. After a reset, the processor will be in supervisor mode.

6.4.3.2 Debug State

The AVR32 can be set in a debug state, which allows implementation of software monitor routines that can read out and alter system information for use during application development. This implies that all system and application registers, including the status registers and program counters, are accessible in debug state. The privileged instructions are also available.

All interrupt levels are by default disabled when debug state is entered, but they can individually be switched on by the monitor routine by clearing the respective mask bit in the status register.

Debug state can be entered as described in the *AVR32UC Technical Reference Manual*.

Debug state is exited by the *retd* instruction.

6.4.4 System Registers

The system registers are placed outside of the virtual memory space, and are only accessible using the privileged *mfsr* and *mtsr* instructions. The table below lists the system registers specified in the AVR32 architecture, some of which are unused in AVR32UC. The programmer is responsible for maintaining correct sequencing of any instructions following a *mtsr* instruction. For detail on the system registers, refer to the *AVR32UC Technical Reference Manual*.

Table 6-3. System Registers

| Reg # | Address | Name | Function |
|-------|---------|----------|--|
| 0 | 0 | SR | Status Register |
| 1 | 4 | EVBA | Exception Vector Base Address |
| 2 | 8 | ACBA | Application Call Base Address |
| 3 | 12 | CPUCR | CPU Control Register |
| 4 | 16 | ECR | Exception Cause Register |
| 5 | 20 | RSR_SUP | Unused in AVR32UC |
| 6 | 24 | RSR_INT0 | Unused in AVR32UC |
| 7 | 28 | RSR_INT1 | Unused in AVR32UC |
| 8 | 32 | RSR_INT2 | Unused in AVR32UC |
| 9 | 36 | RSR_INT3 | Unused in AVR32UC |
| 10 | 40 | RSR_EX | Unused in AVR32UC |
| 11 | 44 | RSR_NMI | Unused in AVR32UC |
| 12 | 48 | RSR_DBG | Return Status Register for Debug mode |
| 13 | 52 | RAR_SUP | Unused in AVR32UC |
| 14 | 56 | RAR_INT0 | Unused in AVR32UC |
| 15 | 60 | RAR_INT1 | Unused in AVR32UC |
| 16 | 64 | RAR_INT2 | Unused in AVR32UC |
| 17 | 68 | RAR_INT3 | Unused in AVR32UC |
| 18 | 72 | RAR_EX | Unused in AVR32UC |
| 19 | 76 | RAR_NMI | Unused in AVR32UC |
| 20 | 80 | RAR_DBG | Return Address Register for Debug mode |
| 21 | 84 | JECR | Unused in AVR32UC |
| 22 | 88 | JOSP | Unused in AVR32UC |
| 23 | 92 | JAVA_LV0 | Unused in AVR32UC |
| 24 | 96 | JAVA_LV1 | Unused in AVR32UC |
| 25 | 100 | JAVA_LV2 | Unused in AVR32UC |

Table 6-3. System Registers (Continued)

| Reg # | Address | Name | Function |
|-------|---------|----------|--|
| 26 | 104 | JAVA_LV3 | Unused in AVR32UC |
| 27 | 108 | JAVA_LV4 | Unused in AVR32UC |
| 28 | 112 | JAVA_LV5 | Unused in AVR32UC |
| 29 | 116 | JAVA_LV6 | Unused in AVR32UC |
| 30 | 120 | JAVA_LV7 | Unused in AVR32UC |
| 31 | 124 | JTBA | Unused in AVR32UC |
| 32 | 128 | JBCR | Unused in AVR32UC |
| 33-63 | 132-252 | Reserved | Reserved for future use |
| 64 | 256 | CONFIG0 | Configuration register 0 |
| 65 | 260 | CONFIG1 | Configuration register 1 |
| 66 | 264 | COUNT | Cycle Counter register |
| 67 | 268 | COMPARE | Compare register |
| 68 | 272 | TLBEHI | Unused in AVR32UC |
| 69 | 276 | TLBELO | Unused in AVR32UC |
| 70 | 280 | PTBR | Unused in AVR32UC |
| 71 | 284 | TLBEAR | Unused in AVR32UC |
| 72 | 288 | MMUCR | Unused in AVR32UC |
| 73 | 292 | TLBARLO | Unused in AVR32UC |
| 74 | 296 | TLBARHI | Unused in AVR32UC |
| 75 | 300 | PCCNT | Unused in AVR32UC |
| 76 | 304 | PCNT0 | Unused in AVR32UC |
| 77 | 308 | PCNT1 | Unused in AVR32UC |
| 78 | 312 | PCCR | Unused in AVR32UC |
| 79 | 316 | BEAR | Bus Error Address Register |
| 80 | 320 | MPUAR0 | MPU Address Register region 0 |
| 81 | 324 | MPUAR1 | MPU Address Register region 1 |
| 82 | 328 | MPUAR2 | MPU Address Register region 2 |
| 83 | 332 | MPUAR3 | MPU Address Register region 3 |
| 84 | 336 | MPUAR4 | MPU Address Register region 4 |
| 85 | 340 | MPUAR5 | MPU Address Register region 5 |
| 86 | 344 | MPUAR6 | MPU Address Register region 6 |
| 87 | 348 | MPUAR7 | MPU Address Register region 7 |
| 88 | 352 | MPUPSR0 | MPU Privilege Select Register region 0 |
| 89 | 356 | MPUPSR1 | MPU Privilege Select Register region 1 |
| 90 | 360 | MPUPSR2 | MPU Privilege Select Register region 2 |
| 91 | 364 | MPUPSR3 | MPU Privilege Select Register region 3 |

Table 6-3. System Registers (Continued)

| Reg # | Address | Name | Function |
|---------|----------|----------|--|
| 92 | 368 | MPUPSR4 | MPU Privilege Select Register region 4 |
| 93 | 372 | MPUPSR5 | MPU Privilege Select Register region 5 |
| 94 | 376 | MPUPSR6 | MPU Privilege Select Register region 6 |
| 95 | 380 | MPUPSR7 | MPU Privilege Select Register region 7 |
| 96 | 384 | MPUCRA | Unused in this version of AVR32UC |
| 97 | 388 | MPUCRB | Unused in this version of AVR32UC |
| 98 | 392 | MPUBRA | Unused in this version of AVR32UC |
| 99 | 396 | MPUBRB | Unused in this version of AVR32UC |
| 100 | 400 | MPUAPRA | MPU Access Permission Register A |
| 101 | 404 | MPUAPRB | MPU Access Permission Register B |
| 102 | 408 | MPUCR | MPU Control Register |
| 103-191 | 448-764 | Reserved | Reserved for future use |
| 192-255 | 768-1020 | IMPL | IMPLEMENTATION DEFINED |

6.5 Exceptions and Interrupts

AVR32UC incorporates a powerful exception handling scheme. The different exception sources, like Illegal Op-code and external interrupt requests, have different priority levels, ensuring a well-defined behavior when multiple exceptions are received simultaneously. Additionally, pending exceptions of a higher priority class may preempt handling of ongoing exceptions of a lower priority class.

When an event occurs, the execution of the instruction stream is halted, and execution control is passed to an event handler at an address specified in [Table 6-4 on page 29](#). Most of the handlers are placed sequentially in the code space starting at the address specified by EVBA, with four bytes between each handler. This gives ample space for a jump instruction to be placed there, jumping to the event routine itself. A few critical handlers have larger spacing between them, allowing the entire event routine to be placed directly at the address specified by the EVBA-relative offset generated by hardware. All external interrupt sources have autovector interrupt service routine (ISR) addresses. This allows the interrupt controller to directly specify the ISR address as an address relative to EVBA. The autovector offset has 14 address bits, giving an offset of maximum 16384 bytes. The target address of the event handler is calculated as $(EVBA \mid \text{event_handler_offset})$, not $(EVBA + \text{event_handler_offset})$, so EVBA and exception code segments must be set up appropriately. The same mechanisms are used to service all different types of events, including external interrupt requests, yielding a uniform event handling scheme.

An interrupt controller does the priority handling of the external interrupts and provides the autovector offset to the CPU.

6.5.1 System Stack Issues

Event handling in AVR32UC uses the system stack pointed to by the system stack pointer, SP_SYS, for pushing and popping R8-R12, LR, status register, and return address. Since event code may be timing-critical, SP_SYS should point to memory addresses in the IRAM section, since the timing of accesses to this memory section is both fast and deterministic.

The user must also make sure that the system stack is large enough so that any event is able to push the required registers to stack. If the system stack is full, and an event occurs, the system will enter an UNDEFINED state.

6.5.2 Exceptions and Interrupt Requests

When an event other than *scall* or debug request is received by the core, the following actions are performed atomically:

1. The pending event will not be accepted if it is masked. The I3M, I2M, I1M, I0M, EM, and GM bits in the Status Register are used to mask different events. Not all events can be masked. A few critical events (NMI, Unrecoverable Exception, TLB Multiple Hit, and Bus Error) can not be masked. When an event is accepted, hardware automatically sets the mask bits corresponding to all sources with equal or lower priority. This inhibits acceptance of other events of the same or lower priority, except for the critical events listed above. Software may choose to clear some or all of these bits after saving the necessary state if other priority schemes are desired. It is the event source's responsibility to ensure that their events are left pending until accepted by the CPU.
2. When a request is accepted, the Status Register and Program Counter of the current context is stored to the system stack. If the event is an INT0, INT1, INT2, or INT3, registers R8-R12 and LR are also automatically stored to stack. Storing the Status Register ensures that the core is returned to the previous execution mode when the current event handling is completed. When exceptions occur, both the EM and GM bits are set, and the application may manually enable nested exceptions if desired by clearing the appropriate bit. Each exception handler has a dedicated handler address, and this address uniquely identifies the exception source.
3. The Mode bits are set to reflect the priority of the accepted event, and the correct register file bank is selected. The address of the event handler, as shown in Table 6-4, is loaded into the Program Counter.

The execution of the event handler routine then continues from the effective address calculated.

The *rete* instruction signals the end of the event. When encountered, the Return Status Register and Return Address Register are popped from the system stack and restored to the Status Register and Program Counter. If the *rete* instruction returns from INT0, INT1, INT2, or INT3, registers R8-R12 and LR are also popped from the system stack. The restored Status Register contains information allowing the core to resume operation in the previous execution mode. This concludes the event handling.

6.5.3 Supervisor Calls

The AVR32 instruction set provides a supervisor mode call instruction. The *scall* instruction is designed so that privileged routines can be called from any context. This facilitates sharing of code between different execution modes. The *scall* mechanism is designed so that a minimal execution cycle overhead is experienced when performing supervisor routine calls from time-critical event handlers.

The *scall* instruction behaves differently depending on which mode it is called from. The behaviour is detailed in the instruction set reference. In order to allow the *scall* routine to return to the correct context, a return from supervisor call instruction, *rets*, is implemented. In the AVR32UC CPU, *scall* and *rets* uses the system stack to store the return address and the status register.

6.5.4 Debug Requests

The AVR32 architecture defines a dedicated Debug mode. When a debug request is received by the core, Debug mode is entered. Entry into Debug mode can be masked by the DM bit in the

status register. Upon entry into Debug mode, hardware sets the SR[D] bit and jumps to the Debug Exception handler. By default, Debug mode executes in the exception context, but with dedicated Return Address Register and Return Status Register. These dedicated registers remove the need for storing this data to the system stack, thereby improving debuggability. The mode bits in the status register can freely be manipulated in Debug mode, to observe registers in all contexts, while retaining full privileges.

Debug mode is exited by executing the *retd* instruction. This returns to the previous context.

6.5.5 Entry Points for Events

Several different event handler entry points exist. In AVR32UC, the reset address is 0x8000_0000. This places the reset address in the boot flash memory area.

TLB miss exceptions and *scall* have a dedicated space relative to EVBA where their event handler can be placed. This speeds up execution by removing the need for a jump instruction placed at the program address jumped to by the event hardware. All other exceptions have a dedicated event routine entry point located relative to EVBA. The handler routine address identifies the exception source directly.

AVR32UC uses the ITLB and DTLB protection exceptions to signal a MPU protection violation. ITLB and DTLB miss exceptions are used to signal that an access address did not map to any of the entries in the MPU. TLB multiple hit exception indicates that an access address did map to multiple TLB entries, signalling an error.

All external interrupt requests have entry points located at an offset relative to EVBA. This autovector offset is specified by an external Interrupt Controller. The programmer must make sure that none of the autovector offsets interfere with the placement of other code. The autovector offset has 14 address bits, giving an offset of maximum 16384 bytes.

Special considerations should be made when loading EVBA with a pointer. Due to security considerations, the event handlers should be located in non-writeable flash memory, or optionally in a privileged memory protection region if an MPU is present.

If several events occur on the same instruction, they are handled in a prioritized way. The priority ordering is presented in Table 6-4. If events occur on several instructions at different locations in the pipeline, the events on the oldest instruction are always handled before any events on any younger instruction, even if the younger instruction has events of higher priority than the oldest instruction. An instruction B is younger than an instruction A if it was sent down the pipeline later than A.

The addresses and priority of simultaneous events are shown in Table 6-4. Some of the exceptions are unused in AVR32UC since it has no MMU, coprocessor interface, or floating-point unit.

Table 6-4. Priority and Handler Addresses for Events

| Priority | Handler Address | Name | Event source | Stored Return Address |
|----------|------------------------|-----------------------------|----------------|---------------------------------|
| 1 | 0x8000_0000 | Reset | External input | Undefined |
| 2 | Provided by OCD system | OCD Stop CPU | OCD system | First non-completed instruction |
| 3 | EVBA+0x00 | Unrecoverable exception | Internal | PC of offending instruction |
| 4 | EVBA+0x04 | TLB multiple hit | MPU | |
| 5 | EVBA+0x08 | Bus error data fetch | Data bus | First non-completed instruction |
| 6 | EVBA+0x0C | Bus error instruction fetch | Data bus | First non-completed instruction |
| 7 | EVBA+0x10 | NMI | External input | First non-completed instruction |
| 8 | Autovectored | Interrupt 3 request | External input | First non-completed instruction |
| 9 | Autovectored | Interrupt 2 request | External input | First non-completed instruction |
| 10 | Autovectored | Interrupt 1 request | External input | First non-completed instruction |
| 11 | Autovectored | Interrupt 0 request | External input | First non-completed instruction |
| 12 | EVBA+0x14 | Instruction Address | CPU | PC of offending instruction |
| 13 | EVBA+0x50 | ITLB Miss | MPU | |
| 14 | EVBA+0x18 | ITLB Protection | MPU | PC of offending instruction |
| 15 | EVBA+0x1C | Breakpoint | OCD system | First non-completed instruction |
| 16 | EVBA+0x20 | Illegal Opcode | Instruction | PC of offending instruction |
| 17 | EVBA+0x24 | Unimplemented instruction | Instruction | PC of offending instruction |
| 18 | EVBA+0x28 | Privilege violation | Instruction | PC of offending instruction |
| 19 | EVBA+0x2C | Floating-point | UNUSED | |
| 20 | EVBA+0x30 | Coprocessor absent | Instruction | PC of offending instruction |
| 21 | EVBA+0x100 | Supervisor call | Instruction | PC(Supervisor Call) +2 |
| 22 | EVBA+0x34 | Data Address (Read) | CPU | PC of offending instruction |
| 23 | EVBA+0x38 | Data Address (Write) | CPU | PC of offending instruction |
| 24 | EVBA+0x60 | DTLB Miss (Read) | MPU | |
| 25 | EVBA+0x70 | DTLB Miss (Write) | MPU | |
| 26 | EVBA+0x3C | DTLB Protection (Read) | MPU | PC of offending instruction |
| 27 | EVBA+0x40 | DTLB Protection (Write) | MPU | PC of offending instruction |
| 28 | EVBA+0x44 | DTLB Modified | UNUSED | |

6.6 Module Configuration

All AT32UC3B parts do not implement the same CPU and Architecture Revision.

Table 6-5. CPU and Architecture Revision

| Part Name | Architecture Revision |
|--------------|-----------------------|
| AT32UC3Bx512 | 2 |
| AT32UC3Bx256 | 1 |
| AT32UC3Bx128 | 1 |
| AT32UC3Bx64 | 1 |

7. Memories

7.1 Embedded Memories

- Internal High-Speed Flash
 - 512KBytes (AT32UC3B0512, AT32UC3B1512)
 - 256 KBytes (AT32UC3B0256, AT32UC3B1256)
 - 128 KBytes (AT32UC3B0128, AT32UC3B1128)
 - 64 KBytes (AT32UC3B064, AT32UC3B164)
 - - 0 Wait State Access at up to 30 MHz in Worst Case Conditions
 - - 1 Wait State Access at up to 60 MHz in Worst Case Conditions
 - - Pipelined Flash Architecture, allowing burst reads from sequential Flash locations, hiding penalty of 1 wait state access
 - - 100 000 Write Cycles, 15-year Data Retention Capability
 - - 4 ms Page Programming Time, 8 ms Chip Erase Time
 - - Sector Lock Capabilities, Bootloader Protection, Security Bit
 - - 32 Fuses, Erased During Chip Erase
 - - User Page For Data To Be Preserved During Chip Erase
- Internal High-Speed SRAM, Single-cycle access at full speed
 - 96KBytes ((AT32UC3B0512, AT32UC3B1512)
 - 32KBytes (AT32UC3B0256, AT32UC3B0128, AT32UC3B1256 and AT32UC3B1128)
 - 16KBytes (AT32UC3B064 and AT32UC3B164)

7.2 Physical Memory Map

The system bus is implemented as a bus matrix. All system bus addresses are fixed, and they are never remapped in any way, not even in boot. Note that AVR32 UC CPU uses unsegmented translation, as described in the AVR32UC Technical Architecture Manual. The 32-bit physical address space is mapped as follows:

Table 7-1. AT32UC3B Physical Memory Map

| Device | | Embedded SRAM | Embedded Flash | USB Data | HSB-PB Bridge A | HSB-PB Bridge B |
|---------------|------------------------------|---------------|----------------|-------------|-----------------|-----------------|
| Start Address | | 0x0000_0000 | 0x8000_0000 | 0xD000_0000 | 0xFFFF_0000 | 0xFFFE_0000 |
| Size | AT32UC3B0512 AT32UC3B1512 | 96 Kbytes | 512 Kbytes | 64 Kbytes | 64 Kbytes | 64 Kbytes |
| | AT32UC3B0256 AT32UC3B1256 | 32 Kbytes | 256 Kbytes | 64 Kbytes | 64 Kbytes | 64 Kbytes |
| | AT32UC3B0128 AT32UC3B1128 | 32 Kbytes | 128 Kbytes | 64 Kbytes | 64 Kbytes | 64 Kbytes |
| | AT32UC3B064 AT32UC3B164 | 16 Kbytes | 64 Kbytes | 64 Kbytes | 64 Kbytes | 64 Kbytes |

7.3 Peripheral Address Map

Table 7-2. Peripheral Address Mapping

| Address | | Peripheral Name |
|------------|---------|--|
| 0xFFFE0000 | USB | USB 2.0 Interface - USB |
| 0xFFFE1000 | HMATRIX | HSB Matrix - HMATRIX |
| 0xFFFE1400 | HFLASHC | Flash Controller - HFLASHC |
| 0xFFFF0000 | PDCA | Peripheral DMA Controller - PDCA |
| 0xFFFF0800 | INTC | Interrupt controller - INTC |
| 0xFFFF0C00 | PM | Power Manager - PM |
| 0xFFFF0D00 | RTC | Real Time Counter - RTC |
| 0xFFFF0D30 | WDT | Watchdog Timer - WDT |
| 0xFFFF0D80 | EIM | External Interrupt Controller - EIM |
| 0xFFFF1000 | GPIO | General Purpose Input/Output Controller - GPIO |
| 0xFFFF1400 | USART0 | Universal Synchronous/Asynchronous Receiver/Transmitter - USART0 |
| 0xFFFF1800 | USART1 | Universal Synchronous/Asynchronous Receiver/Transmitter - USART1 |
| 0xFFFF1C00 | USART2 | Universal Synchronous/Asynchronous Receiver/Transmitter - USART2 |
| 0xFFFF2400 | SPI0 | Serial Peripheral Interface - SPI0 |
| 0xFFFF2C00 | TWI | Two-wire Interface - TWI |
| 0xFFFF3000 | PWM | Pulse Width Modulation Controller - PWM |
| 0xFFFF3400 | SSC | Synchronous Serial Controller - SSC |
| 0xFFFF3800 | TC | Timer/Counter - TC |

Table 7-2. Peripheral Address Mapping

| | | |
|------------|-------|-----------------------------------|
| 0xFFFF3C00 | ADC | Analog to Digital Converter - ADC |
| 0xFFFF4000 | ABDAC | Audio Bitstream DAC - ABDAC |

7.4 CPU Local Bus Mapping

Some of the registers in the GPIO module are mapped onto the CPU local bus, in addition to being mapped on the Peripheral Bus. These registers can therefore be reached both by accesses on the Peripheral Bus, and by accesses on the local bus.

Mapping these registers on the local bus allows cycle-deterministic toggling of GPIO pins since the CPU and GPIO are the only modules connected to this bus. Also, since the local bus runs at CPU speed, one write or read operation can be performed per clock cycle to the local bus-mapped GPIO registers.

The following GPIO registers are mapped on the local bus:

Table 7-3. Local bus mapped GPIO registers

| Port | Register | Mode | Local Bus Address | Access |
|--------------------------|--------------------------------------|-------------|-------------------|------------|
| 0 | Output Driver Enable Register (ODER) | WRITE | 0x4000_0040 | Write-only |
| | | SET | 0x4000_0044 | Write-only |
| | | CLEAR | 0x4000_0048 | Write-only |
| | | TOGGLE | 0x4000_004C | Write-only |
| | Output Value Register (OVR) | WRITE | 0x4000_0050 | Write-only |
| | | SET | 0x4000_0054 | Write-only |
| | | CLEAR | 0x4000_0058 | Write-only |
| | | TOGGLE | 0x4000_005C | Write-only |
| Pin Value Register (PVR) | - | 0x4000_0060 | Read-only | |
| 1 | Output Driver Enable Register (ODER) | WRITE | 0x4000_0140 | Write-only |
| | | SET | 0x4000_0144 | Write-only |
| | | CLEAR | 0x4000_0148 | Write-only |
| | | TOGGLE | 0x4000_014C | Write-only |
| | Output Value Register (OVR) | WRITE | 0x4000_0150 | Write-only |
| | | SET | 0x4000_0154 | Write-only |
| | | CLEAR | 0x4000_0158 | Write-only |
| | | TOGGLE | 0x4000_015C | Write-only |
| Pin Value Register (PVR) | - | 0x4000_0160 | Read-only | |

8. Boot Sequence

This chapter summarizes the boot sequence of the AT32UC3B. The behaviour after power-up is controlled by the Power Manager. For specific details, refer to section Power Manager (PM).

8.1 Starting of clocks

After power-up, the device will be held in a reset state by the Power-On Reset circuitry, until the power has stabilized throughout the device. Once the power has stabilized, the device will use the internal RC Oscillator as clock source.

On system start-up, the PLLs are disabled. All clocks to all modules are running. No clocks have a divided frequency, all parts of the system receives a clock with the same frequency as the internal RC Oscillator.

8.2 Fetching of initial instructions

After reset has been released, the AVR32 UC CPU starts fetching instructions from the reset address, which is 0x8000_0000. This address points to the first address in the internal Flash.

The code read from the internal Flash is free to configure the system to use for example the PLLs, to divide the frequency of the clock routed to some of the peripherals, and to gate the clocks to unused peripherals.

When powering up the device, there may be a delay before the voltage has stabilized, depending on the rise time of the supply used. The CPU can start executing code as soon as the supply is above the POR threshold, and before the supply is stable. Before switching to a high-speed clock source, the user should use the BOD to make sure the VDDCORE is above the minimum level.

9. Power Manager (PM)

Rev: 2.3.0.2

9.1 Features

- Controls integrated oscillators and PLLs
- Generates clocks and resets for digital logic
- Supports 2 crystal oscillators 0.4-20 MHz
- Supports 2 PLLs 80-240 MHz
- Supports 32 KHz ultra-low power oscillator
- Integrated low-power RC oscillator
- On-the fly frequency change of CPU, HSB, PBA, and PBB clocks
- Sleep modes allow simple disabling of logic clocks, PLLs, and oscillators
- Module-level clock gating through maskable peripheral clocks
- Wake-up from internal or external interrupts
- Generic clocks with wide frequency range provided
- Automatic identification of reset sources
- Controls brownout detector (BOD), RC oscillator, and bandgap voltage reference through control and calibration registers

9.2 Description

The Power Manager (PM) controls the oscillators and PLLs, and generates the clocks and resets in the device. The PM controls two fast crystal oscillators, as well as two PLLs, which can multiply the clock from either oscillator to provide higher frequencies. Additionally, a low-power 32 KHz oscillator is used to generate the real-time counter clock for high accuracy real-time measurements. The PM also contains a low-power RC oscillator with fast start-up time, which can be used to clock the digital logic.

The provided clocks are divided into synchronous and generic clocks. The synchronous clocks are used to clock the main digital logic in the device, namely the CPU, and the modules and peripherals connected to the HSB, PBA, and PBB buses. The generic clocks are asynchronous clocks, which can be tuned precisely within a wide frequency range, which makes them suitable for peripherals that require specific frequencies, such as timers and communication modules.

The PM also contains advanced power-saving features, allowing the user to optimize the power consumption for an application. The synchronous clocks are divided into three clock domains, one for the CPU and HSB, one for modules on the PBA bus, and one for modules on the PBB bus. The three clocks can run at different speeds, so the user can save power by running peripherals at a relatively low clock, while maintaining a high CPU performance. Additionally, the clocks can be independently changed on-the-fly, without halting any peripherals. This enables the user to adjust the speed of the CPU and memories to the dynamic load of the application, without disturbing or re-configuring active peripherals.

Each module also has a separate clock, enabling the user to switch off the clock for inactive modules, to save further power. Additionally, clocks and oscillators can be automatically switched off during idle periods by using the sleep instruction on the CPU. The system will return to normal on occurrence of interrupts.

The Power Manager also contains a Reset Controller, which collects all possible reset sources, generates hard and soft resets, and allows the reset source to be identified by software.

9.3 Block Diagram

Figure 9-1. Power Manager block diagram

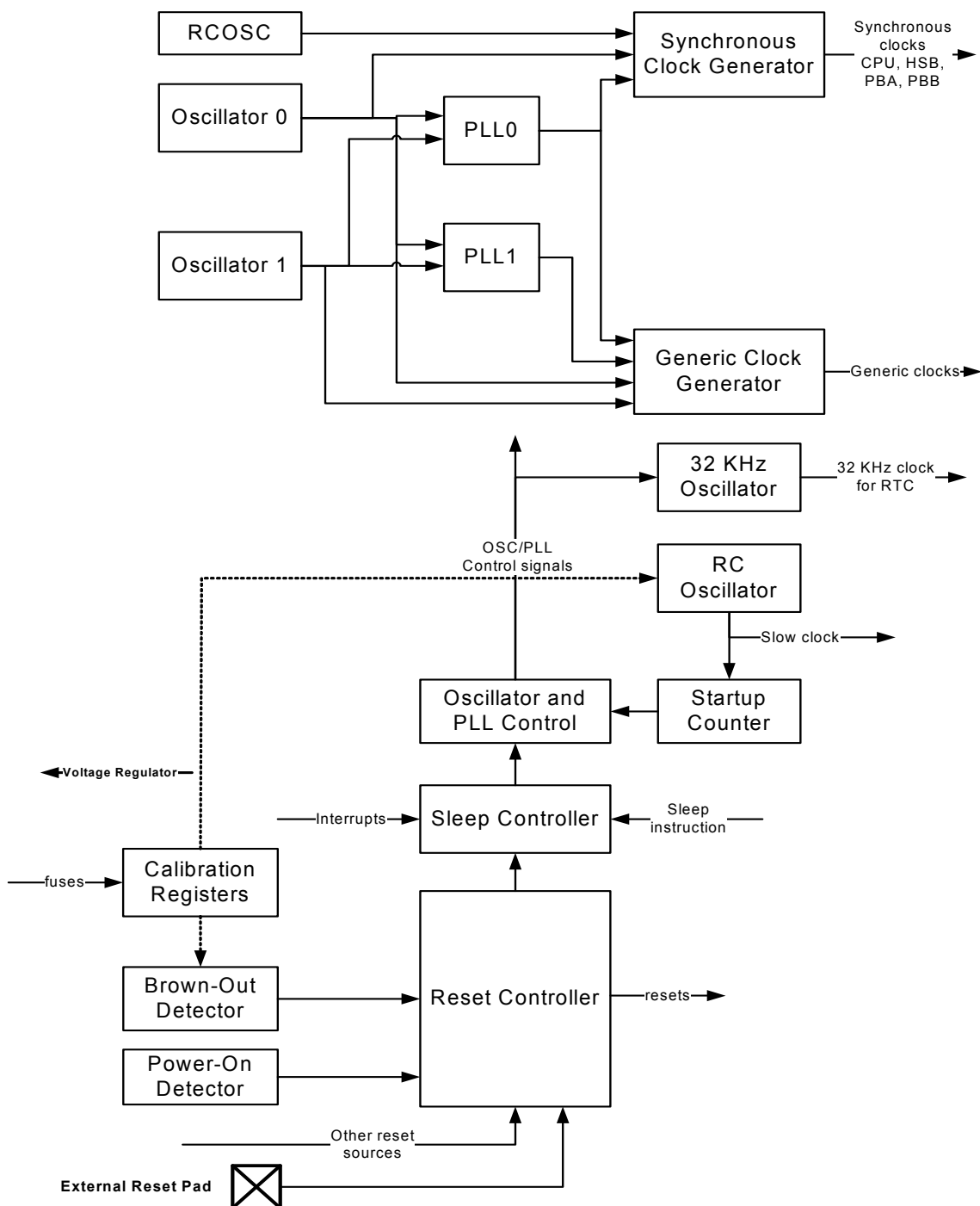

9.4 Product Dependencies

9.4.1 I/O Lines

The PM provides a number of generic clock outputs, which can be connected to output pins, multiplexed with GPIO lines. The programmer must first program the GPIO controller to assign these pins to their peripheral function. If the I/O pins of the PM are not used by the application, they can be used for other purposes by the GPIO controller.

9.4.2 Interrupt

The PM interrupt line is connected to one of the internal sources of the interrupt controller. Using the PM interrupt requires the interrupt controller to be programmed first.

9.4.3 Clock implementation

In AT32UC3B, the HSB shares the source clock with the CPU. This means that writing to the HSBDIV and HSBSEL bits in CKSEL has no effect. These bits will always read the same as CPUDIV and CPUSEL.

9.5 Functional Description

9.5.1 Slow clock

The slow clock is generated from an internal RC oscillator which is always running, except in Static mode. The slow clock can be used for the main clock in the device, as described in "[Synchronous clocks](#)" on page 39. The slow clock is also used for the Watchdog Timer and measuring various delays in the Power Manager.

The RC oscillator has a 3 cycles startup time, and is always available when the CPU is running. The RC oscillator operates at approximately 115 kHz, and can be calibrated to a narrow range by the RCOSCCAL fuses. Software can also change RC oscillator calibration through the use of the RCCR register. Please see the Electrical Characteristics section for details.

RC oscillator can also be used as the RTC clock when crystal accuracy is not required.

9.5.2 Oscillator 0 and 1 operation

The two main oscillators are designed to be used with an external crystal and two biasing capacitors, as shown in [Figure 9-2](#). Oscillator 0 can be used for the main clock in the device, as described in "[Synchronous clocks](#)" on page 39. Both oscillators can be used as source for the generic clocks, as described in "[Generic clocks](#)" on page 43.

The oscillators are disabled by default after reset. When the oscillators are disabled, the XIN and XOUT pins can be used as general purpose I/Os. When the oscillators are configured to use an external clock, the clock must be applied to the XIN pin while the XOUT pin can be used as a general purpose I/O.

The oscillators can be enabled by writing to the OSCnEN bits in MCCTRL. Operation mode (external clock or crystal) is chosen by writing to the MODE field in OSCCTRLn. Oscillators are automatically switched off in certain sleep modes to reduce power consumption, as described in [Section 9.5.7](#) on page 42.

After a hard reset, or when waking up from a sleep mode that disabled the oscillators, the oscillators may need a certain amount of time to stabilize on the correct frequency. This start-up time can be set in the OSCCTRLn register.

The PM masks the oscillator outputs during the start-up time, to ensure that no unstable clocks propagate to the digital logic. The OSCnRDY bits in POSCSR are automatically set and cleared according to the status of the oscillators. A zero to one transition on these bits can also be configured to generate an interrupt, as described in "MODE: Oscillator Mode" on page 57.

Figure 9-2. Oscillator connections

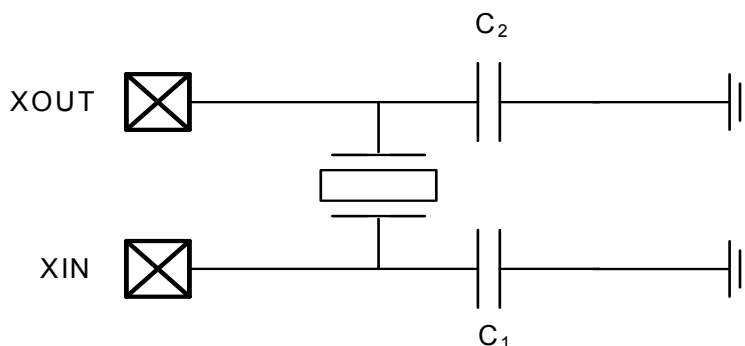

9.5.3 32 KHz oscillator operation

The 32 KHz oscillator operates as described for Oscillator 0 and 1 above. The 32 KHz oscillator is used as source clock for the Real-Time Counter.

The oscillator is disabled by default, but can be enabled by writing OSC32EN in OSCCTRL32. The oscillator is an ultra-low power design and remains enabled in all sleep modes except Static mode.

While the 32 KHz oscillator is disabled, the XIN32 and XOUT32 pins are available as general purpose I/Os. When the oscillator is configured to work with an external clock (MODE field in OSCCTRL32 register), the external clock must be connected to XIN32 while the XOUT32 pin can be used as a general purpose I/O.

The startup time of the 32 KHz oscillator can be set in the OSCCTRL32, after which OSC32RDY in POSCSR is set. An interrupt can be generated on a zero to one transition of OSC32RDY.

As a crystal oscillator usually requires a very long startup time (up to 1 second), the 32 KHz oscillator will keep running across resets, except Power-On-Reset.

9.5.4 PLL operation

The device contains two PLLs, PLL0 and PLL1. These are disabled by default, but can be enabled to provide high frequency source clocks for synchronous or generic clocks. The PLLs can take either Oscillator 0 or 1 as reference clock. The PLL output is divided by a multiplication factor, and the PLL compares the resulting clock to the reference clock. The PLL will adjust its output frequency until the two compared clocks are equal, thus locking the output frequency to a multiple of the reference clock frequency.

The Voltage Controlled Oscillator inside the PLL can generate frequencies from 80 to 240 MHz. To make the PLL output frequencies under 80 MHz the OTP[1] bitfield could be set. This will divide the output of the PLL by two and bring the clock in range of the max frequency of the CPU.

When the PLL is switched on, or when changing the clock source or multiplication factor for the PLL, the PLL is unlocked and the output frequency is undefined. The PLL clock for the digital logic is automatically masked when the PLL is unlocked, to prevent connected digital logic from receiving a too high frequency and thus become unstable.

Figure 9-3. PLL with control logic and filters

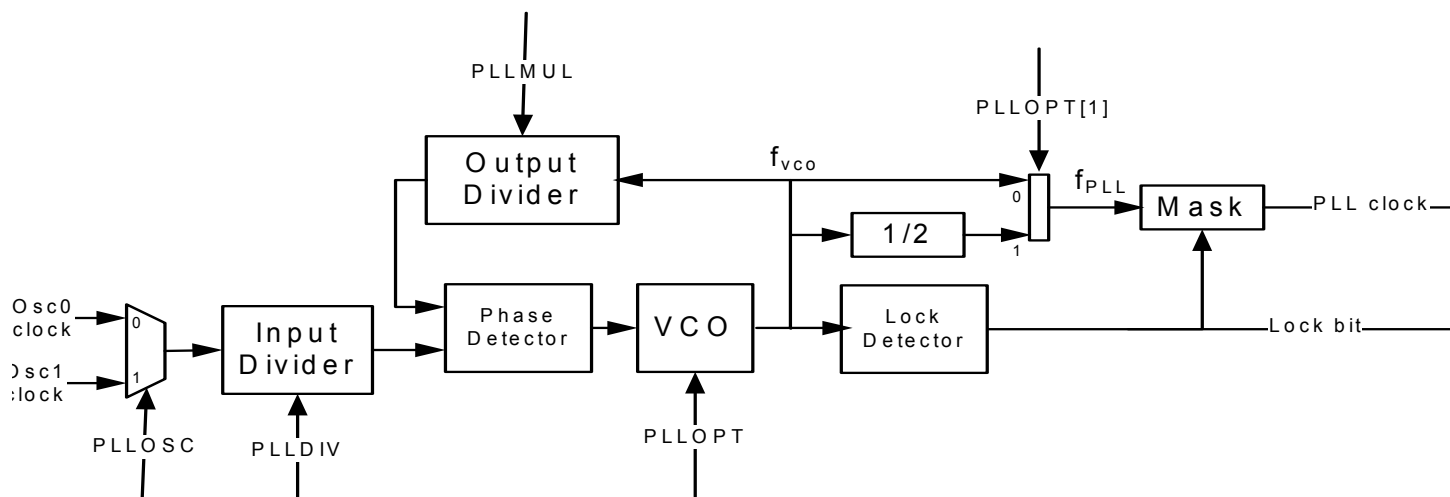

9.5.4.1 Enabling the PLL

PLL_n is enabled by writing the PLEN bit in the PLL_n register. PLLOSC selects Oscillator 0 or 1 as clock source. The PLLMUL and PLLDIV bitfields must be written with the multiplication and division factors, respectively, creating the voltage controlled oscillator frequency f_{VCO} and the PLL frequency f_{PLL} :

$$f_{VCO} = (PLLMUL+1)/(PLLDIV) \cdot f_{OSC} \text{ if } PLLDIV > 0.$$

$$f_{VCO} = 2 \cdot (PLLMUL+1) \cdot f_{OSC} \text{ if } PLLDIV = 0.$$

If PLLOPT[1] field is set to 0:

$$f_{PLL} = f_{VCO}.$$

If PLLOPT[1] field is set to 1:

$$f_{PLL} = f_{VCO} / 2.$$

The PLL_n:PLLOPT field should be set to proper values according to the PLL operating frequency. The PLLOPT field can also be set to divide the output frequency of the PLLs by 2.

The lock signal for each PLL is available as a LOCK_n flag in POSCSR. An interrupt can be generated on a 0 to 1 transition of these bits.

9.5.5 Synchronous clocks

The slow clock (default), Oscillator 0, or PLL0 provide the source for the main clock, which is the common root for the synchronous clocks for the CPU/HSB, PBA, and PBB modules. The main clock is divided by an 8-bit prescaler, and each of these four synchronous clocks can run from

any tapping of this prescaler, or the undivided main clock, as long as $f_{CPU} \leq f_{PBA,B}$. The synchronous clock source can be changed on-the fly, responding to varying load in the application. The clock domains can be shut down in sleep mode, as described in "Sleep modes" on page 42. Additionally, the clocks for each module in the four domains can be individually masked, to avoid power consumption in inactive modules.

Figure 9-4. Synchronous clock generation

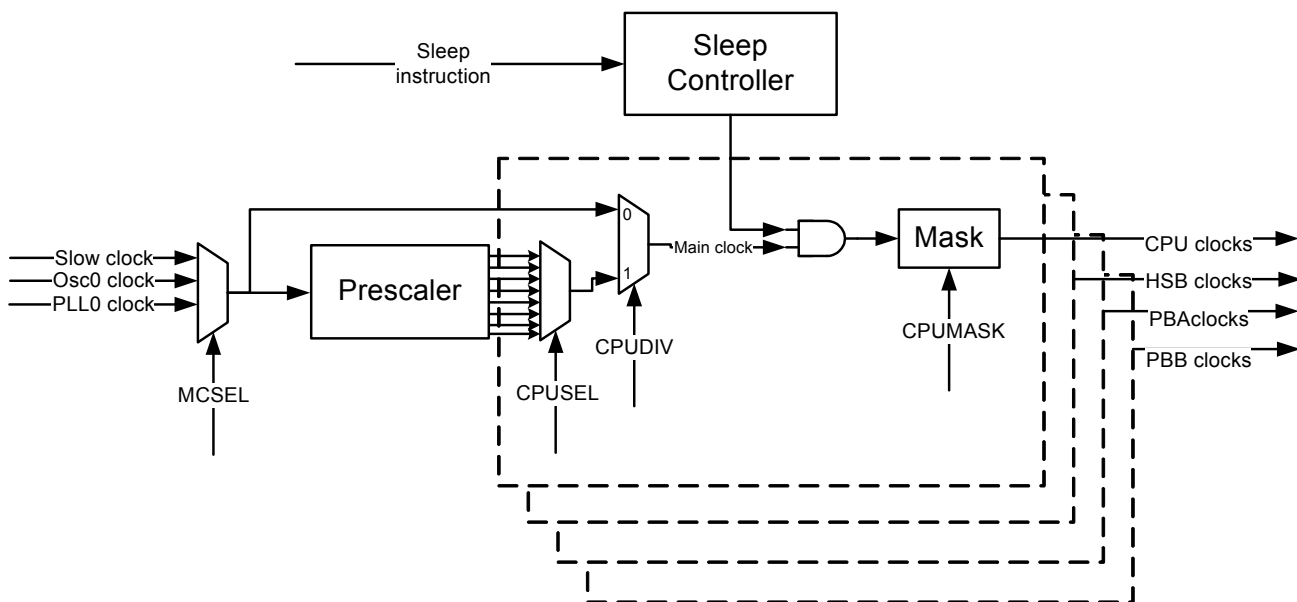

9.5.5.1 Selecting PLL or oscillator for the main clock

The common main clock can be connected to the slow clock, Oscillator 0, or PLL0. By default, the main clock will be connected to the slow clock. The user can connect the main clock to Oscillator 0 or PLL0 by writing the MCSEL bitfield in the Main Clock Control Register (MCCTRL). This must only be done after that unit has been enabled, otherwise a deadlock will occur. Care should also be taken that the new frequency of the synchronous clocks does not exceed the maximum frequency for each clock domain.

9.5.5.2 Selecting synchronous clock division ratio

The main clock feeds an 8-bit prescaler, which can be used to generate the synchronous clocks. By default, the synchronous clocks run on the undivided main clock. The user can select a prescaler division for the CPU clock by writing CKSEL:CPUDIV to 1 and CPUSEL to the prescaling value, resulting in a CPU clock frequency:

$$f_{CPU} = f_{main} / 2^{(CPUSEL+1)}$$

Similarly, the clock for the PBA, and PBB can be divided by writing their respective bitfields. To ensure correct operation, frequencies must be selected so that $f_{\text{CPU}} \square f_{\text{PBA,B}}$. Also, frequencies must never exceed the specified maximum frequency for each clock domain.

CKSEL can be written without halting or disabling peripheral modules. Writing CKSEL allows a new clock setting to be written to all synchronous clocks at the same time. It is possible to keep one or more clocks unchanged by writing the same value a before to the xxxDIV and xxxSEL bitfields. This way, it is possible to e.g. scale CPU and HSB speed according to the required performance, while keeping the PBA and PBB frequency constant.

For modules connected to the HSB bus, the PB clock frequency must be set to the same frequency than the CPU clock.

9.5.5.3 Clock Ready flag

There is a slight delay from CKSEL is written and the new clock setting becomes effective. During this interval, the Clock Ready (CKRDY) flag in ISR will read as 0. If IER:CKRDY is written to 1, the Power Manager interrupt can be triggered when the new clock setting is effective. CKSEL must not be re-written while CKRDY is 0, or the system may become unstable or hang.

9.5.6 Peripheral clock masking

By default, the clock for all modules are enabled, regardless of which modules are actually being used. It is possible to disable the clock for a module in the CPU, HSB, PBA, or PBB clock domain by writing the corresponding bit in the Clock Mask register (CPU/HSB/PBA/PBB) to 0. When a module is not clocked, it will cease operation, and its registers cannot be read or written. The module can be re-enabled later by writing the corresponding mask bit to 1.

A module may be connected to several clock domains, in which case it will have several mask bits.

[Table 9-6](#) contains a list of implemented maskable clocks.

9.5.6.1 Cautionary note

Note that clocks should only be switched off if it is certain that the module will not be used. Switching off the clock for the internal RAM will cause a problem if the stack is mapped there. Switching off the clock to the Power Manager (PM), which contains the mask registers, or the corresponding PBx bridge, will make it impossible to write the mask registers again. In this case, they can only be re-enabled by a system reset.

9.5.6.2 Mask Ready flag

Due to synchronization in the clock generator, there is a slight delay from a mask register is written until the new mask setting goes into effect. When clearing mask bits, this delay can usually be ignored. However, when setting mask bits, the registers in the corresponding module must not be written until the clock has actually be re-enabled. The status flag MSKRDY in ISR provides the required mask status information. When writing either mask register with any value, this bit is cleared. The bit is set when the clocks have been enabled and disabled according to the new mask setting. Optionally, the Power Manager interrupt can be enabled by writing the MSKRDY bit in IER.

9.5.7 Sleep modes

In normal operation, all clock domains are active, allowing software execution and peripheral operation. When the CPU is idle, it is possible to switch off the CPU clock and optionally other clock domains to save power. This is activated by the sleep instruction, which takes the sleep mode index number as argument.

9.5.7.1 Entering and exiting sleep modes

The sleep instruction will halt the CPU and all modules belonging to the stopped clock domains. The modules will be halted regardless of the bit settings of the mask registers.

Oscillators and PLLs can also be switched off to save power. Some of these modules have a relatively long start-up time, and are only switched off when very low power consumption is required.

The CPU and affected modules are restarted when the sleep mode is exited. This occurs when an interrupt triggers. Note that even if an interrupt is enabled in sleep mode, it may not trigger if the source module is not clocked.

9.5.7.2 Supported sleep modes

The following sleep modes are supported. These are detailed in [Table 9-1](#).

- Idle: The CPU is stopped, the rest of the chip is operating. Wake-up sources are any interrupt.
- Frozen: The CPU and HSB modules are stopped, peripherals are operating. Wake-up sources are any interrupts from PB modules.
- Standby: All synchronous clocks are stopped, but oscillators and PLLs are running, allowing quick wake-up to normal mode. Wake-up sources are RTC or external interrupt (EIC), external reset or any asynchronous interrupts from PB modules.
- Stop: As Standby, but Oscillator 0 and 1, and the PLLs are stopped. 32 KHz (if enabled) and RC oscillators and RTC/WDT will still operate. Wake-up are the same as for Standby mode.
- DeepStop: All synchronous clocks, Oscillator 0 and 1 and PLL 0 and 1 are stopped. 32 KHz oscillator can run if enabled. RC oscillator still operates. Bandgap voltage reference and BOD is turned off. Wake-up sources are RTC, external interrupt in asynchronous mode, external reset or any asynchronous interrupts from PB modules.
- Static: All oscillators, including 32 KHz and RC oscillator are stopped. Bandgap voltage reference BOD detector is turned off. Wake-up sources are external interrupt (EIC) in asynchronous mode only, external reset pin or any asynchronous interrupts from PB modules.

Table 9-1. Sleep modes

| Index | Sleep Mode | CPU | HSB | PBA,B GCLK | Osc0,1 PLL0,1, SYSTIMER | Osc32 | RCOsc | BOD & Bandgap | Voltage Regulator |
|-------|------------|------|------|---------------|-------------------------------|-------|-------|------------------|----------------------|
| 0 | Idle | Stop | Run | Run | Run | Run | Run | On | Full power |
| 1 | Frozen | Stop | Stop | Run | Run | Run | Run | On | Full power |
| 2 | Standby | Stop | Stop | Stop | Run | Run | Run | On | Full power |
| 3 | Stop | Stop | Stop | Stop | Stop | Run | Run | On | Low power |
| 4 | DeepStop | Stop | Stop | Stop | Stop | Run | Run | Off | Low power |
| 5 | Static | Stop | Stop | Stop | Stop | Stop | Stop | Off | Low power |

The power level of the internal voltage regulator is also adjusted according to the sleep mode to reduce the internal regulator power consumption.

9.5.7.3 *Precautions when entering sleep mode*

Modules communicating with external circuits should normally be disabled before entering a sleep mode that will stop the module operation. This prevents erratic behavior when entering or exiting sleep mode. Please refer to the relevant module documentation for recommended actions.

Communication between the synchronous clock domains is disturbed when entering and exiting sleep modes. This means that bus transactions are not allowed between clock domains affected by the sleep mode. The system may hang if the bus clocks are stopped in the middle of a bus transaction.

The CPU is automatically stopped in a safe state to ensure that all CPU bus operations are complete when the sleep mode goes into effect. Thus, when entering Idle mode, no further action is necessary.

When entering a sleep mode (except Idle mode), all HSB masters must be stopped before entering the sleep mode. Also, if there is a chance that any PB write operations are incomplete, the CPU should perform a read operation from any register on the PB bus before executing the sleep instruction. This will stall the CPU while waiting for any pending PB operations to complete.

When entering a sleep mode deeper or equal to DeepStop, the VBus asynchronous interrupt should be disabled (USBCON.VBUSTE = 0).

9.5.7.4 *Wake Up*

The USB can be used to wake up the part from sleep modes through register AWEN of the Power Manager.

9.5.8 **Generic clocks**

Timers, communication modules, and other modules connected to external circuitry may require specific clock frequencies to operate correctly. The Power Manager contains an implementation defined number of generic clocks that can provide a wide range of accurate clock frequencies.

Each generic clock module runs from either Oscillator 0 or 1, or PLL0 or 1. The selected source can optionally be divided by any even integer up to 512. Each clock can be independently enabled and disabled, and is also automatically disabled along with peripheral clocks by the Sleep Controller.

Figure 9-5. Generic clock generation

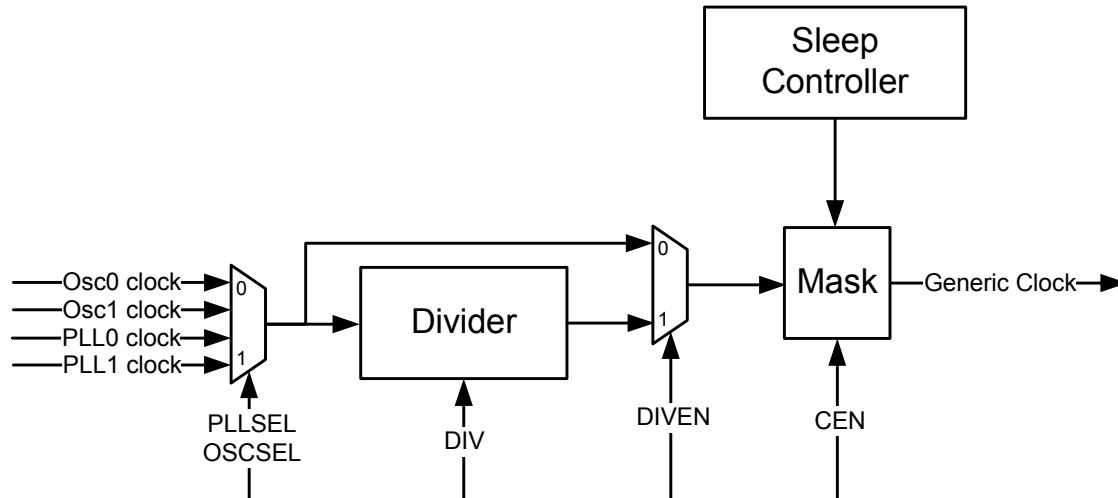

9.5.8.1 Enabling a generic clock

A generic clock is enabled by writing the CEN bit in GCCTRL to 1. Each generic clock can use either Oscillator 0 or 1 or PLL0 or 1 as source, as selected by the PLLSEL and OSCSEL bits. The source clock can optionally be divided by writing DIVEN to 1 and the division factor to DIV, resulting in the output frequency:

$$f_{\text{GCLK}} = f_{\text{SRC}} / (2 * (\text{DIV} + 1))$$

9.5.8.2 Disabling a generic clock

The generic clock can be disabled by writing CEN to 0 or entering a sleep mode that disables the PB clocks. In either case, the generic clock will be switched off on the first falling edge after the disabling event, to ensure that no glitches occur. If CEN is written to 0, the bit will still read as 1 until the next falling edge occurs, and the clock is actually switched off. When writing CEN to 0, the other bits in GCCTRL should not be changed until CEN reads as 0, to avoid glitches on the generic clock.

When the clock is disabled, both the prescaler and output are reset.

9.5.8.3 Changing clock frequency

When changing generic clock frequency by writing GCCTRL, the clock should be switched off by the procedure above, before being re-enabled with the new clock source or division setting. This prevents glitches during the transition.

9.5.8.4 Generic clock implementation

In AT32UC3B, there are 5 generic clocks. These are allocated to different functions as shown in [Table 9-2](#).

Table 9-2. Generic clock allocation

| Clock number | Function |
|--------------|-----------|
| 0 | GCLK0 pin |
| 1 | GCLK1 pin |
| 2 | GCLK2 pin |
| 3 | USBB |
| 4 | ABDAC |

9.5.9 Divided PB clocks

The clock generator in the Power Manager provides divided PBA and PBB clocks for use by peripherals that require a prescaled PBx clock. This is described in the documentation for the relevant modules.

The divided clocks are not directly maskable, but are stopped in sleep modes where the PBx clocks are stopped.

9.5.10 Debug operation

During a debug session, the user may need to halt the system to inspect memory and CPU registers. The clocks normally keep running during this debug operation, but some peripherals may require the clocks to be stopped, e.g. to prevent timer overflow, which would cause the program to fail. For this reason, peripherals on the PBA and PBB buses may use “debug qualified” PBx clocks. This is described in the documentation for the relevant modules. The divided PBx clocks are always debug qualified clocks.

Debug qualified PB clocks are stopped during debug operation. The debug system can optionally keep these clocks running during the debug operation. This is described in the documentation for the On-Chip Debug system.

9.5.11 Reset Controller

The Reset Controller collects the various reset sources in the system and generates hard and soft resets for the digital logic.

The device contains a Power-On Detector, which keeps the system reset until power is stable. This eliminates the need for external reset circuitry to guarantee stable operation when powering up the device.

It is also possible to reset the device by asserting the RESET_N pin. This pin has an internal pull-up, and does not need to be driven externally when negated. [Table 9-4](#) lists these and other reset sources supported by the Reset Controller.

Figure 9-6. Reset Controller block diagram

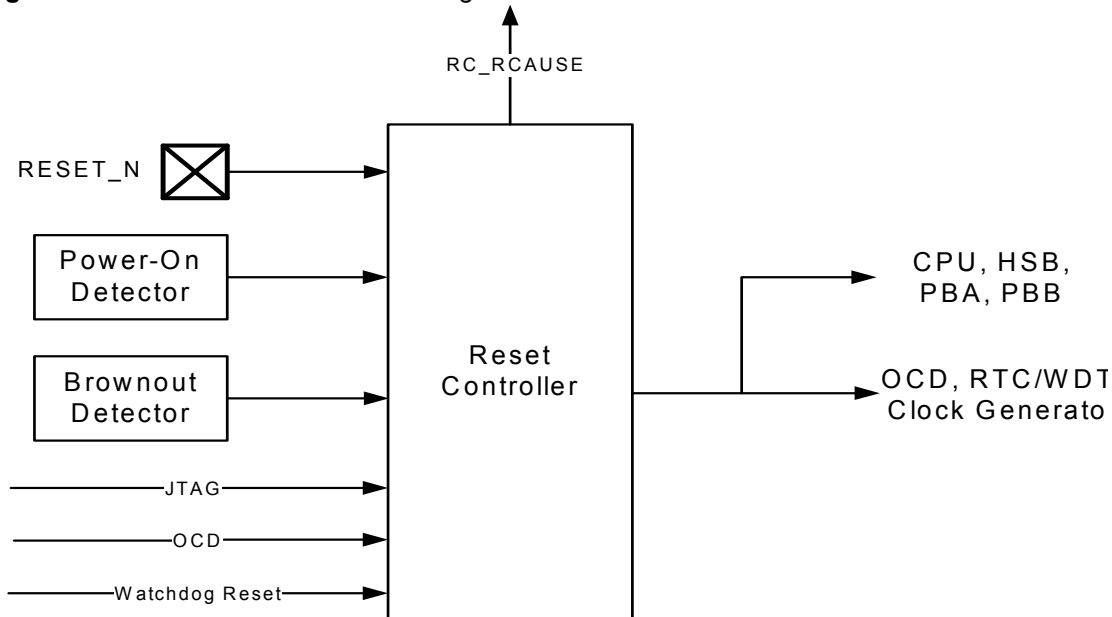

In addition to the listed reset types, the JTAG can keep parts of the device statically reset through the JTAG Reset Register. See JTAG documentation for details.

Table 9-3. Reset description

| Reset source | Description |
|----------------|---|
| Power-on Reset | Supply voltage below the power-on reset detector threshold voltage |
| External Reset | RESET_N pin asserted |
| Brownout Reset | Supply voltage below the brownout reset detector threshold voltage |
| CPU Error | Caused by an illegal CPU access to external memory while in Supervisor mode |
| Watchdog Timer | See watchdog timer documentation. |
| OCD | See On-Chip Debug documentation |

When a Reset occurs, some parts of the chip are not necessarily reset, depending on the reset source. Only the Power On Reset (POR) will force a reset of the whole chip.

Table 9-4 lists parts of the device that are reset, depending on the reset source.

Table 9-4. Effect of the different reset events

| | Power-On Reset | External Reset | Watchdog Reset | BOD Reset | CPU Error Reset | OCD Reset |
|---|----------------|----------------|----------------|-----------|-----------------|-----------|
| CPU/HSB/PBA/PBB (excluding Power Manager) | Y | Y | Y | Y | Y | Y |
| 32 KHz oscillator | Y | N | N | N | N | N |
| RTC control register | Y | N | N | N | N | N |
| GPLP registers | Y | N | N | N | N | N |
| Watchdog control register | Y | Y | N | Y | Y | Y |
| Voltage Calibration register | Y | N | N | N | N | N |
| RC Oscillator Calibration register | Y | N | N | N | N | N |
| BOD control register | Y | Y | N | N | N | N |
| Bandgap control register | Y | Y | N | N | N | N |
| Clock control registers | Y | Y | Y | Y | Y | Y |
| Osc0/Osc1 and control registers | Y | Y | Y | Y | Y | Y |
| PLL0/PLL1 and control registers | Y | Y | Y | Y | Y | Y |
| OCD system and OCD registers | Y | Y | N | Y | Y | N |

The cause of the last reset can be read from the RCAUSE register. This register contains one bit for each reset source, and can be read during the boot sequence of an application to determine the proper action to be taken.

9.5.11.1 Power-On Detector

The Power-On Detector monitors the VDDCORE supply pin and generates a reset when the device is powered on. The reset is active until the supply voltage from the linear regulator is above the power-on threshold level. The reset will be re-activated if the voltage drops below the power-on threshold level. See Electrical Characteristics for parametric details.

9.5.11.2 Brown-Out Detector

The Brown-Out Detector (BOD) monitors the VDDCORE supply pin and compares the supply voltage to the brown-out detection level, as set in BOD.LEVEL. The BOD is disabled by default, but can be enabled either by software or by flash fuses. The Brown-Out Detector can either generate an interrupt or a reset when the supply voltage is below the brown-out detection level. In any case, the BOD output is available in bit POSCR.BODET bit.

Note 1 : Any change to the BOD.LEVEL field of the BOD register should be done with the BOD deactivated to avoid spurious reset or interrupt.

Note 2 : If the BOD level is set to a value higher than VDDCORE and enabled by fuses, the part will be in constant reset. In order to leave reset state, an external voltage higher than the BOD level should be applied. Thus, it is possible to disable BOD.

See Electrical Characteristics for parametric details.

9.5.11.3 *External Reset*

The external reset detector monitors the state of the RESET_N pin. By default, a low level on this pin will generate a reset.

9.5.12 **Calibration registers**

The Power Manager controls the calibration of the RC oscillator, voltage regulator, bandgap voltage reference through several calibration registers.

Those calibration registers are loaded after a Power On Reset with default values stored in factory-programmed flash fuses.

Although it is not recommended to override default factory settings, it is still possible to override these default values by writing to those registers. To prevent unexpected writes due to software bugs, write access to these registers is protected by a “key”. First, a write to the register must be made with the field “KEY” equal to 0x55 then a second write must be issued with the “KEY” field equal to 0xAA

9.6 User Interface
Table 9-5. PM Register Memory Map

| Offset | Register | Register Name | Access | Reset |
|---------------|---------------------------------------|---------------|------------|---------------------|
| 0x0000 | Main Clock Control Register | MCCTRL | Read/Write | 0x00000000 |
| 0x0004 | Clock Select Register | CKSEL | Read/Write | 0x00000000 |
| 0x0008 | CPU Mask Register | CPUMASK | Read/Write | 0x00000003 |
| 0x000C | HSB Mask Register | HSBMASK | Read/Write | 0x0000007F |
| 0x0010 | PBA Mask Register | PBAMASK | Read/Write | 0x00007FFF |
| 0x0014 | PBB Mask Register | PBBMASK | Read/Write | 0x0000003F |
| 0x0020 | PLL0 Control Register | PLL0 | Read/Write | 0x00000000 |
| 0x0024 | PLL1 Control Register | PLL1 | Read/Write | 0x00000000 |
| 0x0028 | Oscillator 0 Control Register | OSCCTRL0 | Read/Write | 0x00000000 |
| 0x002C | Oscillator 1 Control Register | OSCCTRL1 | Read/Write | 0x00000000 |
| 0x0030 | Oscillator 32 Control Register | OSCCTRL32 | Read/Write | 0x00010000 |
| 0x0040 | Interrupt Enable Register | IER | Write-Only | 0x00000000 |
| 0x0044 | Interrupt Disable Register | IDR | Write-Only | 0x00000000 |
| 0x0048 | Interrupt Mask Register | IMR | Read-Only | 0x00000000 |
| 0x004C | Interrupt Status Register | ISR | Read-Only | 0x00000000 |
| 0x0050 | Interrupt Clear Register | ICR | Write-Only | 0x00000000 |
| 0x0054 | Power and Oscillators Status Register | POSCSR | Read/Write | 0x00000000 |
| 0x0060-0x0070 | Generic Clock Control Register | GCCTRL | Read/Write | 0x00000000 |
| 0x00C0 | RC Oscillator Calibration Register | RCCR | Read/Write | Factory settings |
| 0x00C4 | Bandgap Calibration Register | BGCR | Read/Write | Factory settings |
| 0x00C8 | Linear Regulator Calibration Register | VREGCR | Read/Write | Factory settings |
| 0x00D0 | BOD Level Register | BOD | Read/Write | BOD fuses in Flash |
| 0x0140 | Reset Cause Register | RCAUSE | Read-Only | Latest Reset Source |
| 0x0144 | Asynchronous Wake Up Enable Register | AWEN | Read/Write | 0x00000000 |
| 0x0200 | General Purpose Low-Power Register 0 | GPLP0 | Read/Write | 0x00000000 |
| 0x0204 | General Purpose Low-Power Register 1 | GPLP1 | Read/Write | 0x00000000 |

9.6.1 Main Clock Control Register

Name: MCCTRL
Access Type: Read/Write
Offset: 0x000
Reset Value: 0x00000000

| | | | | | | | |
|----|----|----|----|--------|--------|-------|----|
| 31 | 30 | 29 | 28 | 27 | 26 | 25 | 24 |
| - | - | - | - | - | - | - | - |
| 23 | 22 | 21 | 20 | 19 | 18 | 17 | 16 |
| - | - | - | - | - | - | - | - |
| 15 | 14 | 13 | 12 | 11 | 10 | 9 | 8 |
| - | - | - | - | - | - | - | - |
| 7 | 6 | 5 | 4 | 3 | 2 | 1 | 0 |
| - | - | | | OSC1EN | OSC0EN | MCSEL | |

- **OSC1EN: Oscillator 1 Enable**
 0: Oscillator 1 is disabled.
 1: Oscillator 1 is enabled.
- **OSC0EN: Oscillator 0 Enable**
 0: Oscillator 0 is disabled.
 1: Oscillator 0 is enabled.
- **MCSEL: Main Clock Select**
 0: The slow clock is the source for the main clock.
 1: Oscillator 0 is the source for the main clock.
 2: PLL0 is the source for the main clock.
 3: Reserved.
 •

9.6.2 Clock Select Register

Name: CKSEL
Access Type: Read/Write
Offset: 0x004
Reset Value: 0x00000000

| | | | | | | | |
|--------|----|----|----|----|--------|----|----|
| 31 | 30 | 29 | 28 | 27 | 26 | 25 | 24 |
| PBBDIV | - | - | - | - | PBBSEL | | |
| 23 | 22 | 21 | 20 | 19 | 18 | 17 | 16 |
| PBADIV | - | - | - | - | PBASEL | | |
| 15 | 14 | 13 | 12 | 11 | 10 | 9 | 8 |
| HSBDIV | - | - | - | - | HSBSEL | | |
| 7 | 6 | 5 | 4 | 3 | 2 | 1 | 0 |
| CPUDIV | - | - | - | - | CPUSEL | | |

- PBBDIV, PBBSEL: PBB Division and Clock Select**
 PBBDIV = 0: PBB clock equals main clock.
 PBBDIV = 1: PBB clock equals main clock divided by $2^{(PBBSEL+1)}$.
- PBADIV, PBASEL: PBA Division and Clock Select**
 PBADIV = 0: PBA clock equals main clock.
 PBADIV = 1: PBA clock equals main clock divided by $2^{(PBASEL+1)}$.
- HSBDIV, HSBSEL: HSB Division and Clock Select**
 For the AT32UC3B, HSBDIV always equals CPUDIV, and HSBSEL always equals CPUSEL, as the HSB clock is always equal to the CPU clock.
- CPUDIV, CPUSEL: CPU Division and Clock Select**
 CPUDIV = 0: CPU clock equals main clock.
 CPUDIV = 1: CPU clock equals main clock divided by $2^{(CPUSEL+1)}$.

Note that if xxxDIV is written to 0, xxxSEL should also be written to 0 to ensure correct operation.
 Also note that writing this register clears POSCSR:CKRDY. The register must not be re-written until CKRDY goes high.



9.6.3 Clock Mask Register

Name: CPU/HSB/PBA/PBBMASK
Access Type: Read/Write
Offset: 0x008, 0x00C, 0x010, 0x014
Reset Value: -

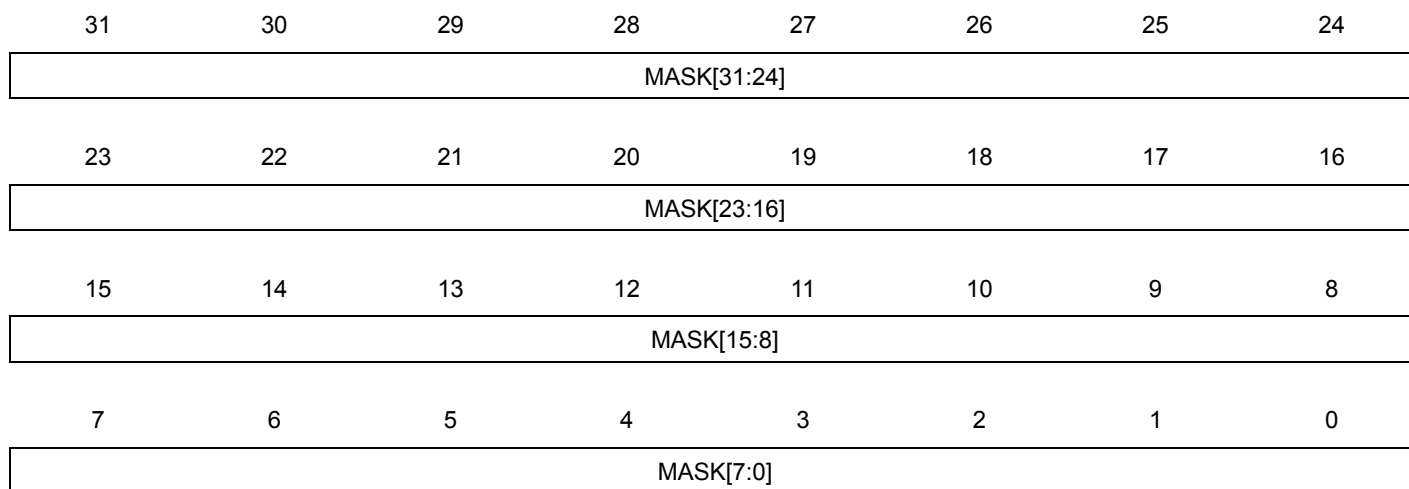

• **MASK: Clock Mask**

If bit n is cleared, the clock for module n is stopped. If bit n is set, the clock for module n is enabled according to the current power mode. The number of implemented bits in each mask register, as well as which module clock is controlled by each bit, is shown in [Table 9-6](#).

Table 9-6. Maskable module clocks in AT32UC3B.

| Bit | CPUMASK | HSBMASK | PBAMASK | PBBMASK |
|-----------|--|------------|------------|---------|
| 0 | - | FLASHC | INTC | HMATRIX |
| 1 | OCD ⁽¹⁾ | PBA bridge | GPIO | USB |
| 2 | - | PBB bridge | PDCA | FLASHC |
| 3 | - | USB | PM/RTC/EIC | - |
| 4 | - | PDCA | ADC | - |
| 5 | - | - | SPI | - |
| 6 | - | - | TWI | - |
| 7 | - | - | USART0 | - |
| 8 | - | - | USART1 | - |
| 9 | - | - | USART2 | - |
| 10 | - | - | PWM | - |
| 11 | - | - | SSC | - |
| 12 | - | - | TC | - |
| 13 | - | - | ABDAC | - |
| 14 | - | - | - | - |
| 15 | - | - | - | - |
| 16 | SYSTIMER (COMPARE/COUNT REGISTERS CLK) | - | - | - |
| 31: 17 | - | - | - | - |

Note: 1. This bit must be one if the user wishes to debug the device with a JTAG debugger.

9.6.4 PLL Control Register

Name: PLL0,1
Access Type: Read/Write
Offset: 0x020, 0x024
Reset Value: 0x00000000

| | | | | | | | |
|----|----|----------|--------|--------|----|--------|------|
| 31 | 30 | 29 | 28 | 27 | 26 | 25 | 24 |
| - | - | PLLCOUNT | | | | | |
| 23 | 22 | 21 | 20 | 19 | 18 | 17 | 16 |
| - | - | - | - | PLLMUL | | | |
| 15 | 14 | 13 | 12 | 11 | 10 | 9 | 8 |
| - | - | - | - | PLLDIV | | | |
| 7 | 6 | 5 | 4 | 3 | 2 | 1 | 0 |
| - | - | - | PLLOPT | | | PLLOSC | PLEN |

- **PLLCOUNT: PLL Count**

Specifies the number of slow clock cycles before ISR:LOCKn will be set after PLLn has been written, or after PLLn has been automatically re-enabled after exiting a sleep mode.

- **PLLMUL: PLL Multiply Factor**

- **PLLDIV: PLL Division Factor**

These fields determine the ratio of the output frequency of the internal VCO of the PLL (f_{VCO}) to the source oscillator frequency:

- $f_{VCO} = (PLLMUL+1)/(PLLDIV) * f_{OSC}$ if PLLDIV > 0.
- $f_{VCO} = 2 * (PLLMUL+1) * f_{OSC}$ if PLLDIV = 0.

If PLLOPT[1] bit is set to 0: $f_{PLL} = f_{VCO}$.

If PLLOPT[1] bit is set to 1: $f_{PLL} = f_{VCO} / 2$.

Note that the PLLMUL field cannot be equal to 0 or 1, or the behavior of the PLL will be undefined.

PLLDIV gives also the input frequency of the PLL (f_{IN}):

if the PLLDIV field is set to 0: $f_{IN} = f_{OSC}$.

if the PLLDIV field is greater than 0: $f_{IN} = f_{OSC} / (2 * PLLDIV)$.

- **PLLOPT: PLL Option**

Select the operating range for the PLL.

PLLOPT[0]: Select the VCO frequency range.

PLLOPT[1]: Enable the extra output divider.

PLLOPT[2]: Disable the Wide-Bandwidth mode (Wide-Bandwidth mode allows a faster startup time and out-of-lock time).

Table 9-7. PLLOPT Fields Description in AT32UC3B

| | Description |
|---------------------------|--|
| PLLOPT[0]: VCO frequency | |
| 0 | $160\text{MHz} < f_{\text{vco}} < 240\text{MHz}$ |
| 1 | $80\text{MHz} < f_{\text{vco}} < 180\text{MHz}$ |
| PLLOPT[1]: Output divider | |
| 0 | $f_{\text{PLL}} = f_{\text{vco}}$ |
| 1 | $f_{\text{PLL}} = f_{\text{vco}}/2$ |
| PLLOPT[2] | |
| 0 | Wide Bandwidth Mode enabled |
| 1 | Wide Bandwidth Mode disabled |

- **PLLOSC: PLL Oscillator Select**
 - 0: Oscillator 0 is the source for the PLL.
 - 1: Oscillator 1 is the source for the PLL.
- **PLLEN: PLL Enable**
 - 0: PLL is disabled.
 - 1: PLL is enabled.

9.6.5 Oscillator 0/1 Control Register

Name: OSCCTRL0,1
Access Type: Read/Write
Offset: 0x028, 0x02C
Reset Value: 0x00000000

| | | | | | | | |
|----|----|----|----|----|---------|----|----|
| 31 | 30 | 29 | 28 | 27 | 26 | 25 | 24 |
| - | - | - | - | - | - | - | - |
| 23 | 22 | 21 | 20 | 19 | 18 | 17 | 16 |
| - | - | - | - | - | - | - | - |
| 15 | 14 | 13 | 12 | 11 | 10 | 9 | 8 |
| - | - | - | - | - | STARTUP | | |
| 7 | 6 | 5 | 4 | 3 | 2 | 1 | 0 |
| - | - | - | - | - | MODE | | |

- **STARTUP: Oscillator Startup Time**
 Select startup time for the oscillator.

Table 9-8. Startup time for oscillators 0 and 1

| STARTUP | Number of RC oscillator clock cycle | Approximative Equivalent time (RCOsc = 115 kHz) |
|---------|-------------------------------------|---|
| 0 | 0 | 0 |
| 1 | 64 | 560 us |
| 2 | 128 | 1.1 ms |
| 3 | 2048 | 18 ms |
| 4 | 4096 | 36 ms |
| 5 | 8192 | 71 ms |
| 6 | 16384 | 142 ms |
| 7 | <i>Reserved</i> | <i>Reserved</i> |

- **MODE: Oscillator Mode**
 Choose between crystal, or external clock
 0: External clock connected on XIN, XOUT can be used as an I/O (no crystal).
 1 to 3: reserved .
 4: Crystal is connected to XIN/XOUT - Oscillator is used with gain G0 (XIN from 0.4 MHz to 0.9 MHz).
 5: Crystal is connected to XIN/XOUT - Oscillator is used with gain G1 (XIN from 0.9 MHz to 3.0 MHz).
 6: Crystal is connected to XIN/XOUT - Oscillator is used with gain G2 (XIN from 3.0 MHz to 8.0 MHz).
 7: Crystal is connected to XIN/XOUT - Oscillator is used with gain G3 (XIN from 8.0 Mhz).

9.6.6 32 KHz Oscillator Control Register

Name: OSCCTRL32

Access Type: Read/Write

Offset: 0x030

Reset Value: 0x00010000

| | | | | | | | |
|----|----|----|----|----|---------|----|---------|
| 31 | 30 | 29 | 28 | 27 | 26 | 25 | 24 |
| - | - | - | - | - | - | - | - |
| 23 | 22 | 21 | 20 | 19 | 18 | 17 | 16 |
| - | - | - | - | - | STARTUP | | |
| 15 | 14 | 13 | 12 | 11 | 10 | 9 | 8 |
| - | - | - | - | - | MODE | | |
| 7 | 6 | 5 | 4 | 3 | 2 | 1 | 0 |
| - | - | - | - | - | - | - | OSC32EN |

Note: This register is only reset by Power-On Reset

- **STARTUP: Oscillator Startup Time**

Select startup time for 32 KHz oscillator.

Table 9-9. Startup time for 32 KHz oscillator

| STARTUP | Number of RC oscillator clock cycle | Approximative Equivalent time (RCOsc = 115 kHz) |
|---------|-------------------------------------|---|
| 0 | 0 | 0 |
| 1 | 128 | 1.1 ms |
| 2 | 8192 | 72.3 ms |
| 3 | 16384 | 143 ms |
| 4 | 65536 | 570 ms |
| 5 | 131072 | 1.1 s |
| 6 | 262144 | 2.3 s |
| 7 | 524288 | 4.6 s |

- **MODE: Oscillator Mode**

Choose between crystal, or external clock.

0: External clock connected on XIN32, XOUT32 can be used as a I/O (no crystal).

1: Crystal is connected to XIN32/XOUT32.

2 to 7: reserved .

- **OSC32EN: Enable the 32 KHz oscillator**

0: 32 KHz Oscillator is disabled.

1: 32 KHz Oscillator is enabled.

9.6.7 Interrupt Enable Register

Name: IER
Access Type: Write-only
Offset: 0x040
Reset Value: 0x00000000

| | | | | | | | |
|---------|--------|-------|----|----|----|----------|---------|
| 31 | 30 | 29 | 28 | 27 | 26 | 25 | 24 |
| - | - | - | - | - | - | - | - |
| 23 | 22 | 21 | 20 | 19 | 18 | 17 | 16 |
| - | - | - | - | - | - | - | BODDET |
| 15 | 14 | 13 | 12 | 11 | 10 | 9 | 8 |
| - | - | - | - | - | - | OSC32RDY | OSC1RDY |
| 7 | 6 | 5 | 4 | 3 | 2 | 1 | 0 |
| OSCORDY | MSKRDY | CKRDY | - | - | - | LOCK1 | LOCK0 |

Writing a zero to a bit in this register has no effect.

Writing a one to a bit in this register will set the corresponding bit in IMR.

9.6.8 Interrupt Disable Register

Name: IDR
Access Type: Write-only
Offset: 0x044
Reset Value: 0x00000000

| | | | | | | | |
|---------|--------|-------|----|----|----|----------|---------|
| 31 | 30 | 29 | 28 | 27 | 26 | 25 | 24 |
| - | - | - | - | - | - | - | - |
| 23 | 22 | 21 | 20 | 19 | 18 | 17 | 16 |
| - | - | - | - | - | - | - | BODDET |
| 15 | 14 | 13 | 12 | 11 | 10 | 9 | 8 |
| - | - | - | - | - | - | OSC32RDY | OSC1RDY |
| 7 | 6 | 5 | 4 | 3 | 2 | 1 | 0 |
| OSCORDY | MSKRDY | CKRDY | - | - | - | LOCK1 | LOCK0 |

Writing a zero to a bit in this register has no effect.

Writing a one to a bit in this register will clear the corresponding bit in IMR.

9.6.9 Interrupt Mask Register

Name: IMR
Access Type: Read-only
Offset: 0x048
Reset Value: 0x00000000

| | | | | | | | |
|---------|--------|-------|----|----|----|----------|---------|
| 31 | 30 | 29 | 28 | 27 | 26 | 25 | 24 |
| - | - | - | - | - | - | - | - |
| 23 | 22 | 21 | 20 | 19 | 18 | 17 | 16 |
| - | - | - | - | - | - | - | BODDET |
| 15 | 14 | 13 | 12 | 11 | 10 | 9 | 8 |
| - | - | - | - | - | - | OSC32RDY | OSC1RDY |
| 7 | 6 | 5 | 4 | 3 | 2 | 1 | 0 |
| OSCORDY | MSKRDY | CKRDY | - | - | - | LOCK1 | LOCK0 |

0: The corresponding interrupt is disabled.

1: The corresponding interrupt is enabled.

A bit in this register is cleared when the corresponding bit in IDR is written to one.

A bit in this register is set when the corresponding bit in IER is written to one.

9.6.10 Interrupt Status Register

Name: ISR
Access Type: Read-only
Offset: 0x04C
Reset Value: 0x00000000

| | | | | | | | |
|---------|--------|-------|----|----|----|----------|---------|
| 31 | 30 | 29 | 28 | 27 | 26 | 25 | 24 |
| - | - | - | - | - | - | - | - |
| 23 | 22 | 21 | 20 | 19 | 18 | 17 | 16 |
| - | - | - | - | - | - | - | BODDET |
| 15 | 14 | 13 | 12 | 11 | 10 | 9 | 8 |
| - | - | - | - | - | - | OSC32RDY | OSC1RDY |
| 7 | 6 | 5 | 4 | 3 | 2 | 1 | 0 |
| OSC0RDY | MSKRDY | CKRDY | - | - | - | LOCK1 | LOCK0 |

- **BODDET: Brown out detection**
Set to 1 when 0 to 1 transition on POSCSR:BODDET bit is detected: BOD has detected that power supply is going below BOD reference value.
- **OSC32RDY: 32 KHz oscillator Ready**
Set to 1 when 0 to 1 transition on the POSCSR:OSC32RDY bit is detected: The 32 KHz oscillator is stable and ready to be used as clock source.
- **OSC1RDY: Oscillator 1 Ready**
Set to 1 when 0 to 1 transition on the POSCSR:OSC1RDY bit is detected: Oscillator 1 is stable and ready to be used as clock source.
- **OSC0RDY: Oscillator 0 Ready**
Set to 1 when 0 to 1 transition on the POSCSR:OSC1RDY bit is detected: Oscillator 1 is stable and ready to be used as clock source.
- **MSKRDY: Mask Ready**
Set to 1 when 0 to 1 transition on the POSCSR:MSKRDY bit is detected: Clocks are now masked according to the (CPU/HSB/PBA/PBB)_MASK registers.
- **CKRDY: Clock Ready**
0: The CKSEL register has been written, and the new clock setting is not yet effective.
1: The synchronous clocks have frequencies as indicated in the CKSEL register.
Note: Writing ICR:CKRDY to 1 has no effect.
- **LOCK1: PLL1 locked**
Set to 1 when 0 to 1 transition on the POSCSR:LOCK1 bit is detected: PLL 1 is locked and ready to be selected as clock source.
- **LOCK0: PLL0 locked**
Set to 1 when 0 to 1 transition on the POSCSR:LOCK0 bit is detected: PLL 0 is locked and ready to be selected as clock source.

9.6.11 Interrupt Clear Register

Name: ICR
Access Type: Write-only
Offset: 0x050
Reset Value: 0x00000000

| | | | | | | | |
|---------|--------|-------|----|----|----|----------|---------|
| 31 | 30 | 29 | 28 | 27 | 26 | 25 | 24 |
| - | - | - | - | - | - | - | - |
| 23 | 22 | 21 | 20 | 19 | 18 | 17 | 16 |
| - | - | - | - | - | - | - | BODDET |
| 15 | 14 | 13 | 12 | 11 | 10 | 9 | 8 |
| - | - | - | - | - | - | OSC32RDY | OSC1RDY |
| 7 | 6 | 5 | 4 | 3 | 2 | 1 | 0 |
| OSCORDY | MSKRDY | CKRDY | - | - | - | LOCK1 | LOCK0 |

Writing a zero to a bit in this register has no effect.

Writing a one to a bit in this register will clear the corresponding bit in ISR.

9.6.12 Power and Oscillators Status Register

Name: POSCSR
Access Type: Read-only
Offset: 0x054
Reset Value: 0x00000000

| | | | | | | | |
|---------|--------|-------|----|----|------|----------|---------|
| 31 | 30 | 29 | 28 | 27 | 26 | 25 | 24 |
| - | - | - | - | - | - | - | - |
| 23 | 22 | 21 | 20 | 19 | 18 | 17 | 16 |
| - | - | - | - | - | - | - | BODDET |
| 15 | 14 | 13 | 12 | 11 | 10 | 9 | 8 |
| - | - | - | - | - | - | OSC32RDY | OSC1RDY |
| 7 | 6 | 5 | 4 | 3 | 2 | 1 | 0 |
| OSC0RDY | MSKRDY | CKRDY | - | - | WAKE | LOCK1 | LOCK0 |

- **BODDET: Brown out detection**
 0: No BOD event.
 1: BOD has detected that power supply is going below BOD reference value.
- **OSC32RDY: 32 KHz oscillator Ready**
 0: The 32 KHz oscillator is not enabled or not ready.
 1: The 32 KHz oscillator is stable and ready to be used as clock source.
- **OSC1RDY: OSC1 ready**
 0: Oscillator 1 not enabled or not ready.
 1: Oscillator 1 is stable and ready to be used as clock source.
- **OSC0RDY: OSC0 ready**
 0: Oscillator 0 not enabled or not ready.
 1: Oscillator 0 is stable and ready to be used as clock source.
- **MSKRDY: Mask ready**
 0: Mask register has been changed, masking in progress.
 1: Clock are masked according to xxx_MASK.
- **CKRDY:**
 0: The CKSEL register has been written, and the new clock setting is not yet effective.
 1: The synchronous clocks have frequencies as indicated in the CKSEL register.
- **LOCK1: PLL 1 locked**
 0: PLL 1 is unlocked.
 1: PLL 1 is locked, and ready to be selected as clock source.
- **LOCK0: PLL 0 locked**
 0: PLL 0 is unlocked.
 1: PLL 0 is locked, and ready to be selected as clock source.

9.6.13 Generic Clock Control Register

Name: GCCTRL
Access Type: Read/Write
Offset: 0x060 - 0x070
Reset Value: 0x00000000

| | | | | | | | |
|----------|----|----|-------|----|-----|--------|--------|
| 31 | 30 | 29 | 28 | 27 | 26 | 25 | 24 |
| - | - | - | - | - | - | - | - |
| 23 | 22 | 21 | 20 | 19 | 18 | 17 | 16 |
| - | - | - | - | - | - | - | - |
| 15 | 14 | 13 | 12 | 11 | 10 | 9 | 8 |
| DIV[7:0] | | | | | | | |
| 7 | 6 | 5 | 4 | 3 | 2 | 1 | 0 |
| - | - | - | DIVEN | - | CEN | PLLSEL | OSCSEL |

There is one GCCTRL register per generic clock in the design.

- **DIV: Division Factor**
- **DIVEN: Divide Enable**
 - 0: The generic clock equals the undivided source clock.
 - 1: The generic clock equals the source clock divided by $2*(DIV+1)$.
- **CEN: Clock Enable**
 - 0: Clock is stopped.
 - 1: Clock is running.
- **PLLSEL: PLL Select**
 - 0: Oscillator is source for the generic clock.
 - 1: PLL is source for the generic clock.
- **OSCSEL: Oscillator Select**
 - 0: Oscillator (or PLL) 0 is source for the generic clock.
 - 1: Oscillator (or PLL) 1 is source for the generic clock.

9.6.14 RC Oscillator Calibration Register

Name: RCCR
Access Type: Read/Write
Offset: 0x0C0
Reset Value: -

| | | | | | | | |
|------------|----|----|----|----|----|------------|-----|
| 31 | 30 | 29 | 28 | 27 | 26 | 25 | 24 |
| KEY | | | | | | | |
| 23 | 22 | 21 | 20 | 19 | 18 | 17 | 16 |
| - | - | - | - | - | - | - | FCD |
| 15 | 14 | 13 | 12 | 11 | 10 | 9 | 8 |
| - | - | - | - | - | - | CALIB[9:8] | |
| 7 | 6 | 5 | 4 | 3 | 2 | 1 | 0 |
| CALIB[7:0] | | | | | | | |

- **KEY: Register Write protection**
 This field must be written twice, first with key value 0x55, then 0xAA, for a write operation to have an effect.
- **CALIB: Calibration Value**
 Calibration Value for the RC oscillator.
- **FCD: Flash Calibration Done**
 - Set to 1 when the CALIB field has been updated by the Flash fuses after power-on reset or Flash fuses update.
 - 0: Allow subsequent overwriting of the CALIB value by Flash fuses.
 - 1: The CALIB value will not be updated again by Flash fuses.

9.6.15 Bandgap Calibration Register

Name: BGCR
Access Type: Read/Write
Offset: 0x0C4
Reset Value: -

| | | | | | | | |
|-----|----|----|----|----|-------|----|-----|
| 31 | 30 | 29 | 28 | 27 | 26 | 25 | 24 |
| KEY | | | | | | | |
| 23 | 22 | 21 | 20 | 19 | 18 | 17 | 16 |
| - | - | - | - | - | - | - | FCD |
| 15 | 14 | 13 | 12 | 11 | 10 | 9 | 8 |
| - | - | - | - | - | - | - | - |
| 7 | 6 | 5 | 4 | 3 | 2 | 1 | 0 |
| - | - | - | - | - | CALIB | | |

- **KEY: Register Write protection**
 This field must be written twice, first with key value 0x55, then 0xAA, for a write operation to have an effect.
- **CALIB: Calibration value**
 Calibration value for Bandgap. See Electrical Characteristics for voltage values.
- **FCD: Flash Calibration Done**
 - Set to 1 when the CALIB field has been updated by the Flash fuses after power-on reset or Flash fuses update.
 - 0: Allow subsequent overwriting of the CALIB value by Flash fuses.
 - 1: The CALIB value will not be updated again by Flash fuses.

9.6.16 Voltage Regulator Calibration Register

Name:: VREGCR
Register access: Read/Write
Offset: 0x0C8
Reset Value: -

| | | | | | | | |
|-----|----|----|----|----|-------|----|-----|
| 31 | 30 | 29 | 28 | 27 | 26 | 25 | 24 |
| KEY | | | | | | | |
| 23 | 22 | 21 | 20 | 19 | 18 | 17 | 16 |
| - | - | - | - | - | - | - | FCD |
| 15 | 14 | 13 | 12 | 11 | 10 | 9 | 8 |
| - | - | - | - | - | - | - | - |
| 7 | 6 | 5 | 4 | 3 | 2 | 1 | 0 |
| - | - | - | - | - | CALIB | | |

- **KEY: Register Write protection**
 - This field must be written twice, first with key value 0x55, then 0xAA, for a write operation to have an effect.
- **CALIB: Calibration value**
 - Calibration value for Voltage Regulator. The user can change this value to decrease or increase the Voltage Regulator output voltage.
- **FCD: Flash Calibration Done**
 - Set to 1 when the CALIB field has been updated by the Flash fuses after power-on reset or Flash fuses update.
 - 0: Allow subsequent overwriting of the CALIB value by Flash fuses.
 - 1: The CALIB value will not be updated again by Flash fuses.
 -
 -

9.6.17 BOD Level Register

Name: BOD
Access Type: Read/Write
Offset: 0x0D0
Reset Value: -

| | | | | | | | |
|-----|------|-------|----|----|----|------|-----|
| 31 | 30 | 29 | 28 | 27 | 26 | 25 | 24 |
| KEY | | | | | | | |
| 23 | 22 | 21 | 20 | 19 | 18 | 17 | 16 |
| - | - | - | - | - | - | - | FCD |
| 15 | 14 | 13 | 12 | 11 | 10 | 9 | 8 |
| - | - | - | - | - | - | CTRL | |
| 7 | 6 | 5 | 4 | 3 | 2 | 1 | 0 |
| - | HYST | LEVEL | | | | | |

- **KEY: Register Write protection**
 - This field must be written twice, first with key value 0x55, then 0xAA, for a write operation to have an effect.
- **FCD: BOD Fuse calibration done**
 - Set to 1 when CTRL, HYST and LEVEL fields has been updated by the Flash fuses after power-on reset or Flash fuses update.
 - 0: Allow subsequent overwriting of the value by Flash fuses.
 - 1: The CTRL, HYST and LEVEL values will not be updated again by Flash fuses.
- **CTRL: BOD Control**
 - 0: BOD is off.
 - 1: BOD is enabled and can reset the chip.
 - 2: BOD is enabled and but cannot reset the chip. Only interrupt will be sent to interrupt controller, if enabled in the IMR register.
 - 3: BOD is off.
- **HYST: BOD Hysteresis**
 - 0: No hysteresis
 - 1: Hysteresis On
- **LEVEL: BOD Level**
 - This field sets the triggering threshold of the BOD. See Electrical Characteristics for actual voltage levels.
 - Note that any change to the LEVEL field of the BOD register should be done with the BOD deactivated to avoid spurious reset or interrupt.

9.6.18 Reset Cause Register

Name: RCAUSE
Access Type: Read-only
Offset: 0x140
Reset Value: Latest Reset Source

| | | | | | | | |
|----|----|----|------|-----|-----|-----|--------|
| 31 | 30 | 29 | 28 | 27 | 26 | 25 | 24 |
| - | - | - | - | - | - | - | - |
| 23 | 22 | 21 | 20 | 19 | 18 | 17 | 16 |
| - | - | - | - | - | - | - | - |
| 15 | 14 | 13 | 12 | 11 | 10 | 9 | 8 |
| - | - | - | - | - | - | - | OCDRST |
| 7 | 6 | 5 | 4 | 3 | 2 | 1 | 0 |
| - | - | - | JTAG | WDT | EXT | BOD | POR |

- **OCDRST: OCD Reset**
 - The CPU was reset because the RES strobe in the OCD Development Control register has been written to one.
- **JTAG: JTAG reset**
 - The CPU was reset by setting the bit RC_CPU in the JTAG reset register.
- **WDT: Watchdog Reset**
 - The CPU was reset because of a watchdog time-out.
- **EXT: External Reset Pin**
 - The CPU was reset due to the RESET pin being asserted.
- **BOD: Brown-out Reset**
 - The CPU was reset due to the supply voltage being lower than the brown-out threshold level.
- **POR Power-on Reset**
 - The CPU was reset due to the supply voltage being lower than the power-on threshold level.

9.6.19 Asynchronous Wake Up Enable Register

Name: AWEN
Access Type: Read/Write
Offset: 0x144
Reset Value: 0x00000000

| | | | | | | | |
|----|----|----|----|----|----|----|-----------|
| 31 | 30 | 29 | 28 | 27 | 26 | 25 | 24 |
| - | - | - | - | - | - | - | - |
| 23 | 22 | 21 | 20 | 19 | 18 | 17 | 16 |
| - | - | - | - | - | - | - | - |
| 15 | 14 | 13 | 12 | 11 | 10 | 9 | 8 |
| - | - | - | - | - | - | - | - |
| 7 | 6 | 5 | 4 | 3 | 2 | 1 | 0 |
| - | - | - | - | - | - | - | USB_WAKEN |

- **USB_WAKEN : USB Wake Up Enable**
 - 0: The USB wake up is disabled.
 - 1: The USB wake up is enabled.

9.6.20 General Purpose Low-power Register 0/1

Name: GPLP
Access Type: Read/Write
Offset: 0x200
Reset Value: 0x00000000

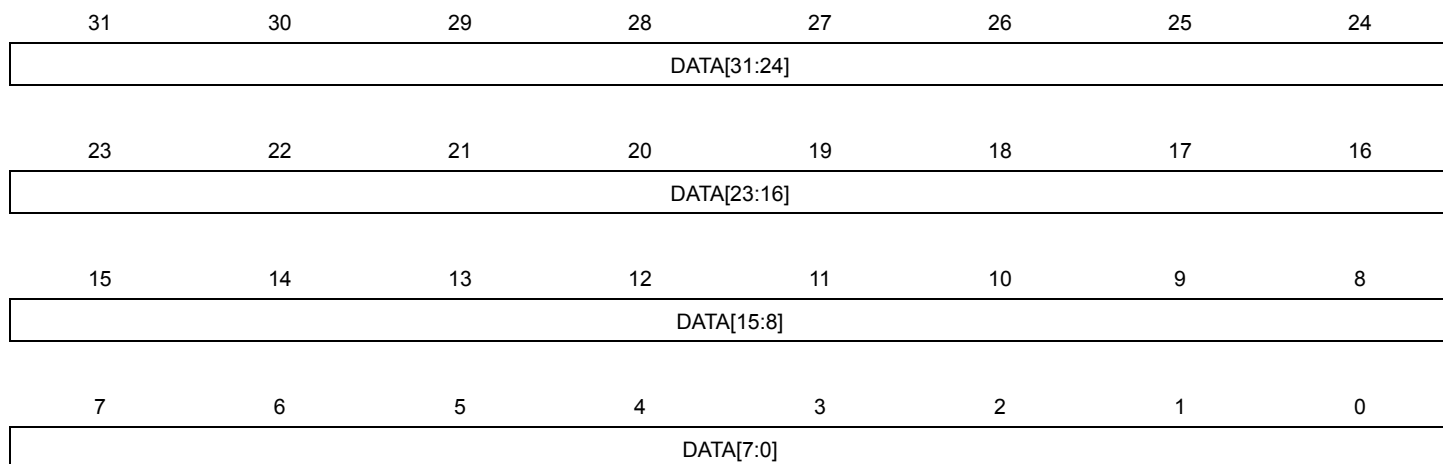

These registers are general purpose 32-bit registers that are reset only by power-on-reset. Any other reset will keep the content of these registers untouched. User software can use these registers to save context variables in a very low power mode. Two GPLP register are implemented in AT32UC3B.

10. Real Time Counter (RTC)

Rev: 2.3.1.1

10.1 Features

- 32-bit real-time counter with 16-bit prescaler
- Clocked from RC oscillator or 32KHz oscillator
- Long delays
 - Max timeout 272years
- High resolution: Max count frequency 16KHz
- Extremely low power consumption
- Available in all sleep modes except Static
- Interrupt on wrap

10.2 Overview

The Real Time Counter (RTC) enables periodic interrupts at long intervals, or accurate measurement of real-time sequences. The RTC is fed from a 16-bit prescaler, which is clocked from the system RC oscillator or the 32KHz crystal oscillator. Any tapping of the prescaler can be selected as clock source for the RTC, enabling both high resolution and long timeouts. The prescaler cannot be written directly, but can be cleared by the user.

The RTC can generate an interrupt when the counter wraps around the value stored in the top register (TOP), producing accurate periodic interrupts.

10.3 Block Diagram

Figure 10-1. Real Time Counter Block Diagram

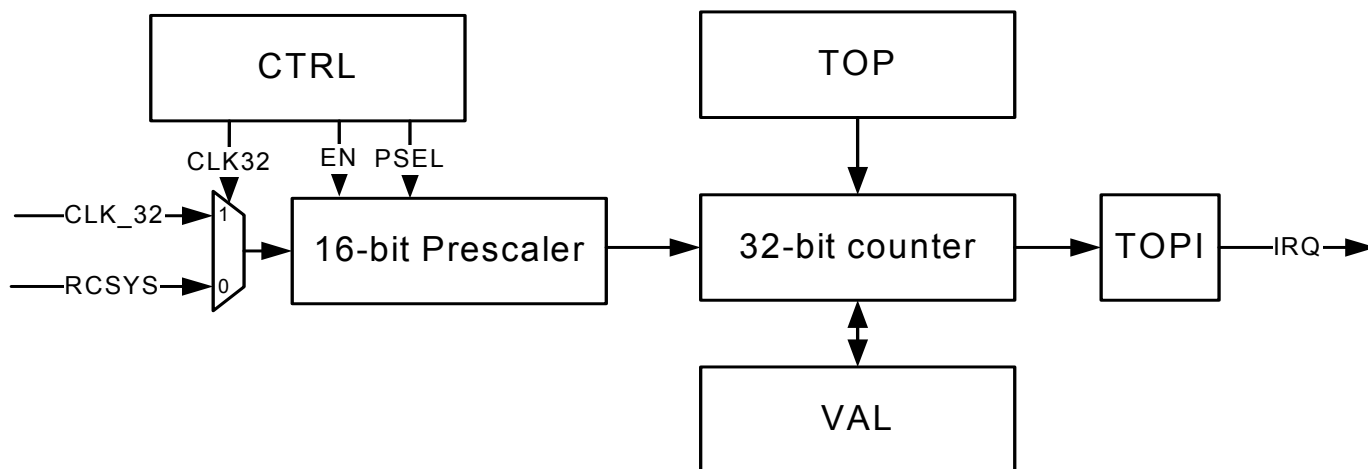

10.4 Product Dependencies

In order to use this module, other parts of the system must be configured correctly, as described below.

10.4.1 Power Management

The RTC remains operating in all sleep modes except Static mode. Interrupts are not available in DeepStop mode.

10.4.2 Clocks

The RTC can use the system RC oscillator as clock source. This oscillator is always enabled whenever this module is active. Please refer to the Electrical Characteristics chapter for the characteristic frequency of this oscillator (f_{RC}).

The RTC can also use the 32 KHz crystal oscillator as clock source. This oscillator must be enabled before use. Please refer to the Power Manager chapter for details.

The clock for the RTC bus interface (CLK_RTC) is generated by the Power Manager. This clock is enabled at reset, and can be disabled in the Power Manager. It is recommended to disable the RTC before disabling the clock, to avoid freezing the RTC in an undefined state.

10.4.3 Interrupts

The RTC interrupt request line is connected to the interrupt controller. Using the RTC interrupt requires the interrupt controller to be programmed first.

10.4.4 Debug Operation

The RTC prescaler is frozen during debug operation, unless the OCD system keeps peripherals running in debug operation.

10.5 Functional Description

10.5.1 RTC Operation

10.5.1.1 Source clock

The RTC is enabled by writing a one to the Enable bit in the Control Register (CTRL.EN). The 16-bit prescaler will then increment on the selected clock. The prescaler cannot be read or written, but it can be reset by writing a one to the Prescaler Clear bit in CTRL register (CTRL.PCLR).

The 32KHz Oscillator Select bit in CTRL register (CTRL.CLK32) selects either the RC oscillator or the 32KHz oscillator as clock source (defined as INPUT in the formula below) for the prescaler.

The Prescale Select field in CTRL register (CTRL.PSEL) selects the prescaler tapping, selecting the source clock for the RTC:

$$f_{RTC} = f_{INPUT} / 2^{(PSEL + 1)}$$

10.5.1.2 Counter operation

When enabled, the RTC will increment until it reaches TOP, and then wraps to 0x0. The status bit TOPI in Interrupt Status Register (ISR) is set to one when this occurs. From 0x0 the counter will count TOP+1 cycles of the source clock before it wraps back to 0x0.

The RTC count value can be read from or written to the Value register (VAL). Due to synchronization, continuous reading of the VAL register with the lowest prescaler setting will skip every other value.

10.5.1.3 *RTC interrupt*

The RTC interrupt is enabled by writing a one to the Top Interrupt bit in the Interrupt Enable Register (IER.TOPI), and is disabled by writing a one to the Top Interrupt bit in the Interrupt Disable Register (IDR.TOPI). The Interrupt Mask Register (IMR) can be read to see whether or not the interrupt is enabled. If enabled, an interrupt will be generated if the TOPI bit in the Interrupt Status Register (ISR) is set. The TOPI bit in ISR can be cleared by writing a one to the TOPI bit in the Interrupt Clear Register (ICR.TOPI).

The RTC interrupt can wake the CPU from all sleep modes except DeepStop and Static modes.

10.5.1.4 *RTC wakeup*

The RTC can also wake up the CPU directly without triggering an interrupt when the ISR.TOPI bit is set. In this case, the CPU will continue executing from the instruction following the sleep instruction.

This direct RTC wake-up is enabled by writing a one to the Wake Enable bit in the CTRL register (CTRL.WAKEN). When the CPU wakes from sleep, the CTRL.WAKEN bit must be written to zero to clear the internal wake signal to the sleep controller, otherwise a new sleep instruction will have no effect.

The RTC wakeup is available in all sleep modes except Static mode. The RTC wakeup can be configured independently of the RTC interrupt.

10.5.1.5 *Busy bit*

Due to the crossing of clock domains, the RTC uses a few clock cycles to propagate the values stored in CTRL, TOP, and VAL to the RTC. The RTC Busy bit in CTRL (CTRL.BUSY) indicates that a register write is still going on and all writes to TOP, CTRL, and VAL will be discarded until the CTRL.BUSY bit goes low again.

10.6 User Interface

Table 10-1. RTC Register Memory Map

| Offset | Register | Register Name | Access | Reset |
|--------|----------------------------|---------------|------------|------------|
| 0x00 | Control Register | CTRL | Read/Write | 0x00010000 |
| 0x04 | Value Register | VAL | Read/Write | 0x00000000 |
| 0x08 | Top Register | TOP | Read/Write | 0xFFFFFFFF |
| 0x10 | Interrupt Enable Register | IER | Write-only | 0x00000000 |
| 0x14 | Interrupt Disable Register | IDR | Write-only | 0x00000000 |
| 0x18 | Interrupt Mask Register | IMR | Read-only | 0x00000000 |
| 0x1C | Interrupt Status Register | ISR | Read-only | 0x00000000 |
| 0x20 | Interrupt Clear Register | ICR | Write-only | 0x00000000 |

10.6.1 Control Register

Name: CTRL
Access Type: Read/Write
Offset: 0x00
Reset Value: 0x00010000

| | | | | | | | |
|----|----|----|------|-------|-------|------|-------|
| 31 | 30 | 29 | 28 | 27 | 26 | 25 | 24 |
| - | - | - | - | - | - | - | - |
| 23 | 22 | 21 | 20 | 19 | 18 | 17 | 16 |
| - | - | - | - | - | - | - | CLKEN |
| 15 | 14 | 13 | 12 | 11 | 10 | 9 | 8 |
| - | - | - | - | PSEL | | | |
| 7 | 6 | 5 | 4 | 3 | 2 | 1 | 0 |
| - | - | - | BUSY | CLK32 | WAKEN | PCLR | EN |

- **CLKEN: Clock Enable**
 1: The clock is enabled.
 0: The clock is disabled.
- **PSEL: Prescale Select**
 Selects prescaler bit PSEL as source clock for the RTC.
- **BUSY: RTC Busy**
 This bit is set when the RTC is busy and will discard writes to TOP, VAL, and CTRL.
 This bit is cleared when the RTC accepts writes to TOP, VAL, and CTRL.
- **CLK32: 32 KHz Oscillator Select**
 1: The RTC uses the 32 KHz oscillator as clock source.
 0: The RTC uses the RC oscillator as clock source.
- **WAKEN: Wakeup Enable**
 1: The RTC wakes up the CPU from sleep modes.
 0: The RTC does not wake up the CPU from sleep modes.
- **PCLR: Prescaler Clear**
 Writing a one to this bit clears the prescaler.
 Writing a zero to this bit has no effect.
 This bit always reads as zero.
- **EN: Enable**
 1: The RTC is enabled.
 0: The RTC is disabled.

10.6.2 Value Register

Name: VAL
Access Type: Read/Write
Offset: 0x04
Reset Value: 0x00000000

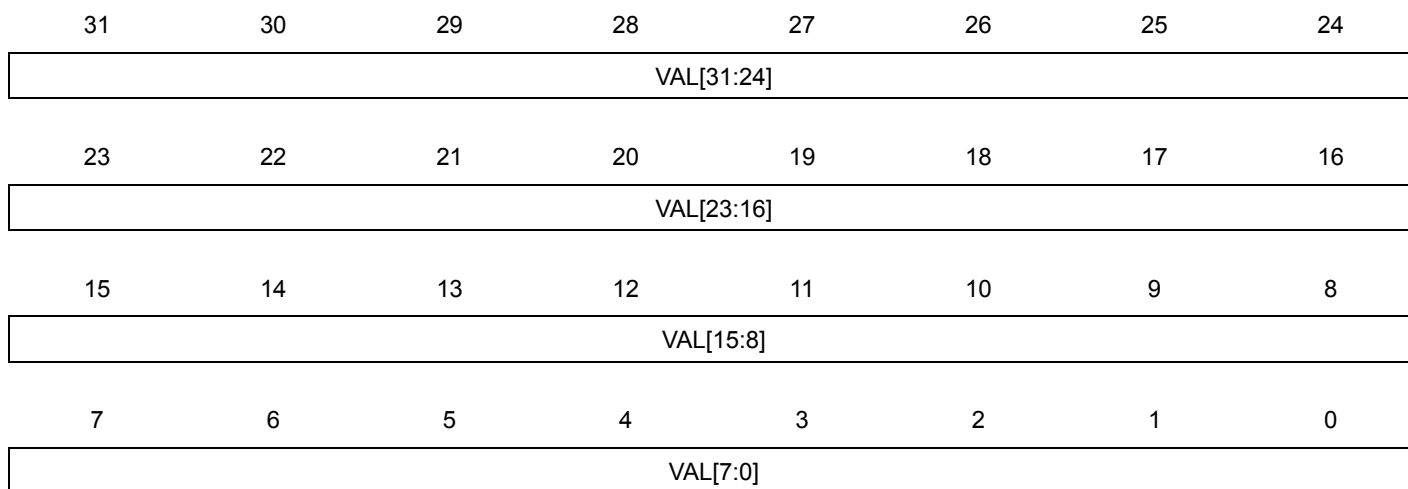

- VAL[31:0]: RTC Value**
 This value is incremented on every rising edge of the source clock.

10.6.3 Top Register

Name: TOP
Access Type: Read/Write
Offset: 0x08
Reset Value: 0xFFFFFFFF

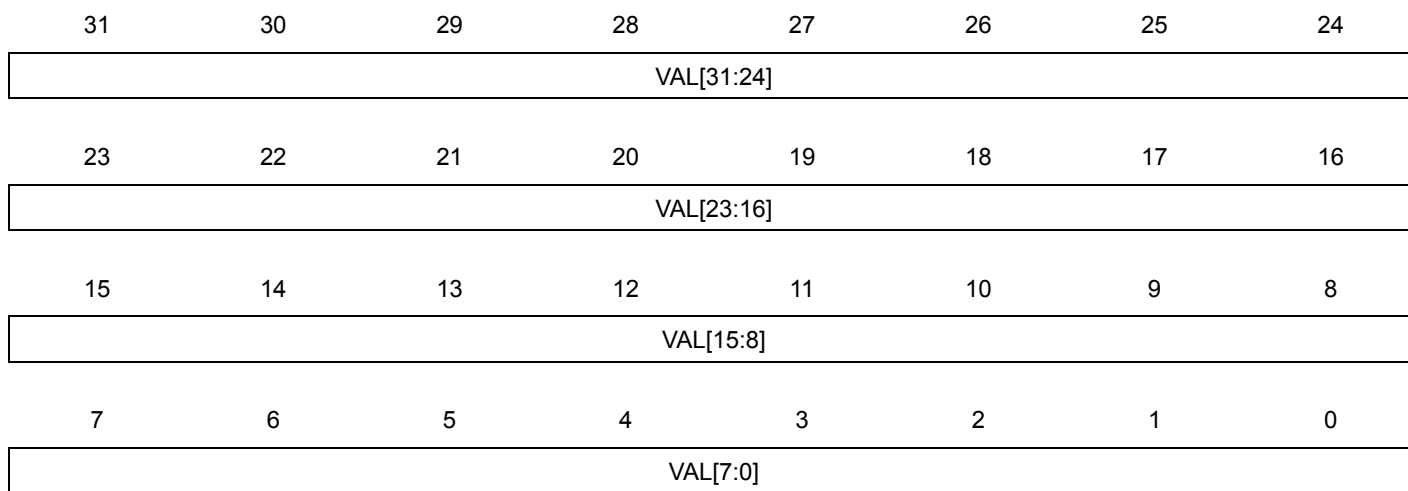

- VAL[31:0]: RTC Top Value**
 VAL wraps at this value.

10.6.4 Interrupt Enable Register

Name: IER
Access Type: Write-only
Offset: 0x10
Reset Value: 0x00000000

| | | | | | | | |
|----|----|----|----|----|----|----|------|
| 31 | 30 | 29 | 28 | 27 | 26 | 25 | 24 |
| - | - | - | - | - | - | - | - |
| 23 | 22 | 21 | 20 | 19 | 18 | 17 | 16 |
| - | - | - | - | - | - | - | - |
| 15 | 14 | 13 | 12 | 11 | 10 | 9 | 8 |
| - | - | - | - | - | - | - | - |
| 7 | 6 | 5 | 4 | 3 | 2 | 1 | 0 |
| - | - | - | - | - | - | - | TOPI |

Writing a zero to a bit in this register has no effect.

Writing a one to a bit in this register will set the corresponding bit in IMR.

10.6.5 Interrupt Disable Register

Name: IDR
Access Type: Write-only
Offset: 0x14
Reset Value: 0x00000000

| | | | | | | | |
|----|----|----|----|----|----|----|------|
| 31 | 30 | 29 | 28 | 27 | 26 | 25 | 24 |
| - | - | - | - | - | - | - | - |
| 23 | 22 | 21 | 20 | 19 | 18 | 17 | 16 |
| - | - | - | - | - | - | - | - |
| 15 | 14 | 13 | 12 | 11 | 10 | 9 | 8 |
| - | - | - | - | - | - | - | - |
| 7 | 6 | 5 | 4 | 3 | 2 | 1 | 0 |
| - | - | - | - | - | - | - | TOPI |

Writing a zero to a bit in this register has no effect.

Writing a one to a bit in this register will clear the corresponding bit in IMR.

10.6.6 Interrupt Mask Register

Name: IMR
Access Type: Read-only
Offset: 0x18
Reset Value: 0x00000000

| | | | | | | | |
|----|----|----|----|----|----|----|------|
| 31 | 30 | 29 | 28 | 27 | 26 | 25 | 24 |
| - | - | - | - | - | - | - | - |
| 23 | 22 | 21 | 20 | 19 | 18 | 17 | 16 |
| - | - | - | - | - | - | - | - |
| 15 | 14 | 13 | 12 | 11 | 10 | 9 | 8 |
| - | - | - | - | - | - | - | - |
| 7 | 6 | 5 | 4 | 3 | 2 | 1 | 0 |
| - | - | - | - | - | - | - | TOPI |

0: The corresponding interrupt is disabled.

1: The corresponding interrupt is enabled.

A bit in this register is cleared when the corresponding bit in IDR is written to one.

A bit in this register is set when the corresponding bit in IER is written to one.

10.6.7 Interrupt Status Register

Name: ISR
Access Type: Read-only
Offset: 0x1C
Reset Value: 0x00000000

| | | | | | | | |
|----|----|----|----|----|----|----|------|
| 31 | 30 | 29 | 28 | 27 | 26 | 25 | 24 |
| - | - | - | - | - | - | - | - |
| 23 | 22 | 21 | 20 | 19 | 18 | 17 | 16 |
| - | - | - | - | - | - | - | - |
| 15 | 14 | 13 | 12 | 11 | 10 | 9 | 8 |
| - | - | - | - | - | - | - | - |
| 7 | 6 | 5 | 4 | 3 | 2 | 1 | 0 |
| - | - | - | - | - | - | - | TOPI |

- **TOPI: Top Interrupt**

This bit is set when VAL has wrapped at its top value.

This bit is cleared when the corresponding bit in ICR is written to one.

10.6.8 Interrupt Clear Register

Name: ICR
Access Type: Write-only
Offset: 0x20
Reset Value: 0x00000000

| | | | | | | | |
|----|----|----|----|----|----|----|------|
| 31 | 30 | 29 | 28 | 27 | 26 | 25 | 24 |
| - | - | - | - | - | - | - | - |
| 23 | 22 | 21 | 20 | 19 | 18 | 17 | 16 |
| - | - | - | - | - | - | - | - |
| 15 | 14 | 13 | 12 | 11 | 10 | 9 | 8 |
| - | - | - | - | - | - | - | - |
| 7 | 6 | 5 | 4 | 3 | 2 | 1 | 0 |
| - | - | - | - | - | - | - | TOPI |

Writing a zero to a bit in this register has no effect.

Writing a one to a bit in this register will clear the corresponding bit in SR and the corresponding interrupt request.

11. Watchdog Timer (WDT)

Rev: 2.3.1.1

11.1 Features

- Watchdog timer counter with 32-bit prescaler
- Clocked from the system RC oscillator (RCSYS)

11.2 Overview

The Watchdog Timer (WDT) has a prescaler generating a time-out period. This prescaler is clocked from the RC oscillator. The watchdog timer must be periodically reset by software within the time-out period, otherwise, the device is reset and starts executing from the boot vector. This allows the device to recover from a condition that has caused the system to be unstable.

11.3 Block Diagram

Figure 11-1. WDT Block Diagram

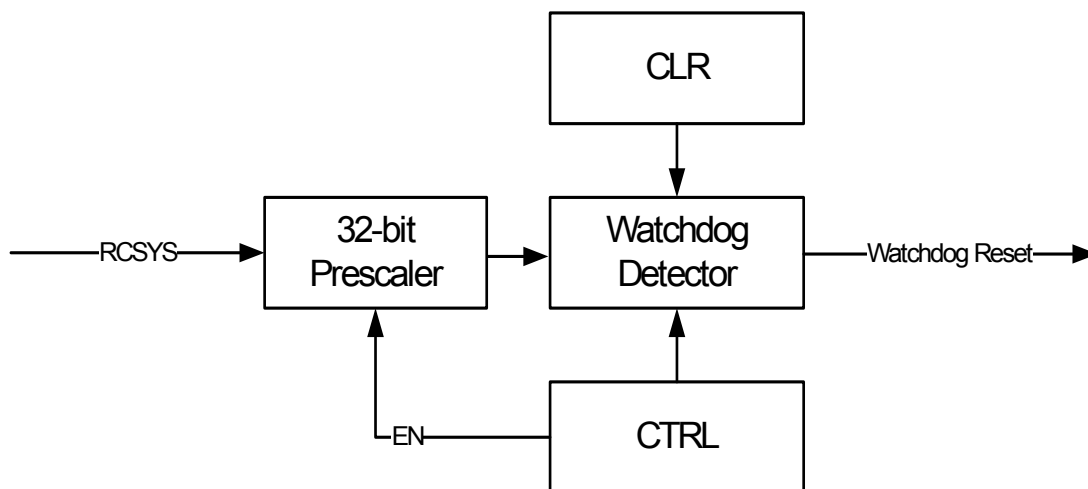

11.4 Product Dependencies

In order to use this module, other parts of the system must be configured correctly, as described below.

11.4.1 Power Management

When the WDT is enabled, the WDT remains clocked in all sleep modes, and it is not possible to enter Static mode.

11.4.2 Clocks

The WDT can use the system RC oscillator (RCSYS) as clock source. This oscillator is always enabled whenever these modules are active. Please refer to the Electrical Characteristics chapter for the characteristic frequency of this oscillator (f_{RC}).

11.4.3 Debug Operation

The WDT prescaler is frozen during debug operation, unless the On-Chip Debug (OCD) system keeps peripherals running in debug operation.

11.5 Functional Description

The WDT is enabled by writing a one to the Enable bit in the Control register (CTRL.EN). This also enables the system RC clock (CLK_RCSYS) for the prescaler. The Prescale Select field (PSEL) in the CTRL register selects the watchdog time-out period:

$$T_{\text{WDT}} = 2^{(\text{PSEL}+1)} / f_{\text{RC}}$$

The next time-out period will begin as soon as the watchdog reset has occurred and count down during the reset sequence. Care must be taken when selecting the PSEL field value so that the time-out period is greater than the startup time of the chip, otherwise a watchdog reset can reset the chip before any code has been run.

To avoid accidental disabling of the watchdog, the CTRL register must be written twice, first with the KEY field set to 0x55, then 0xAA without changing the other bits. Failure to do so will cause the write operation to be ignored, and the CTRL register value will not change.

The Clear register (CLR) must be written with any value with regular intervals shorter than the watchdog time-out period. Otherwise, the device will receive a soft reset, and the code will start executing from the boot vector.

When the WDT is enabled, it is not possible to enter Static mode. Attempting to do so will result in entering Shutdown mode, leaving the WDT operational.

11.6 User Interface

Table 11-1. WDT Register Memory Map

| Offset | Register | Register Name | Access | Reset |
|--------|------------------|---------------|------------|------------|
| 0x00 | Control Register | CTRL | Read/Write | 0x00000000 |
| 0x04 | Clear Register | CLR | Write-only | 0x00000000 |

11.6.1 Control Register

Name: CTRL
Access Type: Read/Write
Offset: 0x00
Reset Value: 0x00000000

| | | | | | | | | |
|-----|----|----|------|----|----|----|----|---|
| 31 | 30 | 29 | 28 | 27 | 26 | 25 | 24 | |
| KEY | | | | | | | | |
| 23 | 22 | 21 | 20 | 19 | 18 | 17 | 16 | |
| - | - | - | - | - | - | - | - | |
| 15 | 14 | 13 | 12 | 11 | 10 | 9 | 8 | |
| - | - | - | PSEL | | | | | - |
| 7 | 6 | 5 | 4 | 3 | 2 | 1 | 0 | |
| - | - | - | - | - | - | - | EN | |

- **KEY: Write protection key**

This field must be written twice, first with key value 0x55, then 0xAA, for a write operation to be effective.
 This field always reads as zero.

- **PSEL: Prescale Select**

PSEL is used as watchdog timeout period.

- **EN: WDT Enable**

1: WDT is enabled.
 0: WDT is disabled.

11.6.2 Clear Register

Name: CLR
Access Type: Write-only
Offset: 0x04
Reset Value: 0x00000000

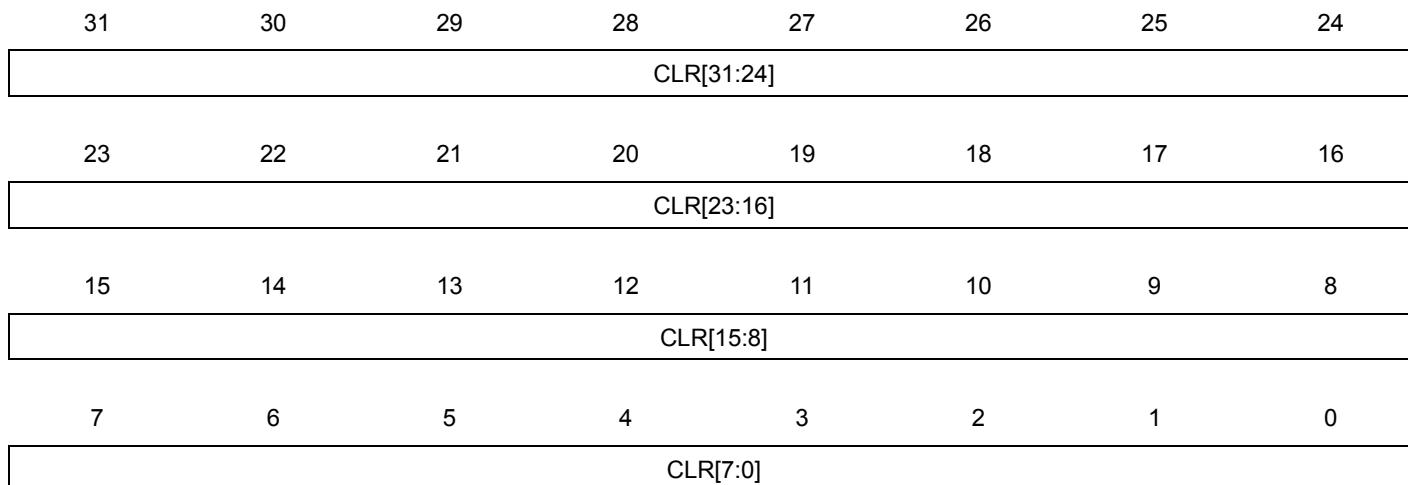

- CLR:** Writing periodically any value to this field when the WDT is enabled, within the watchdog time-out period, will prevent a watchdog reset.
 This field always reads as zero.

12. Interrupt Controller (INTC)

Rev: 1.0.1.5

12.1 Features

- **Autovector low latency interrupt service with programmable priority**
 - 4 priority levels for regular, maskable interrupts
 - One Non-Maskable Interrupt
- **Up to 64 groups of interrupts with up to 32 interrupt requests in each group**

12.2 Overview

The INTC collects interrupt requests from the peripherals, prioritizes them, and delivers an interrupt request and an autovector to the CPU. The AVR32 architecture supports 4 priority levels for regular, maskable interrupts, and a Non-Maskable Interrupt (NMI).

The INTC supports up to 64 groups of interrupts. Each group can have up to 32 interrupt request lines, these lines are connected to the peripherals. Each group has an Interrupt Priority Register (IPR) and an Interrupt Request Register (IRR). The IPRs are used to assign a priority level and an autovector to each group, and the IRRs are used to identify the active interrupt request within each group. If a group has only one interrupt request line, an active interrupt group uniquely identifies the active interrupt request line, and the corresponding IRR is not needed. The INTC also provides one Interrupt Cause Register (ICR) per priority level. These registers identify the group that has a pending interrupt of the corresponding priority level. If several groups have a pending interrupt of the same level, the group with the lowest number takes priority.

12.3 Block Diagram

[Figure 12-1](#) gives an overview of the INTC. The grey boxes represent registers that can be accessed via the user interface. The interrupt requests from the peripherals (IREQ_n) and the NMI are input on the left side of the figure. Signals to and from the CPU are on the right side of the figure.

Figure 12-1. INTC Block Diagram

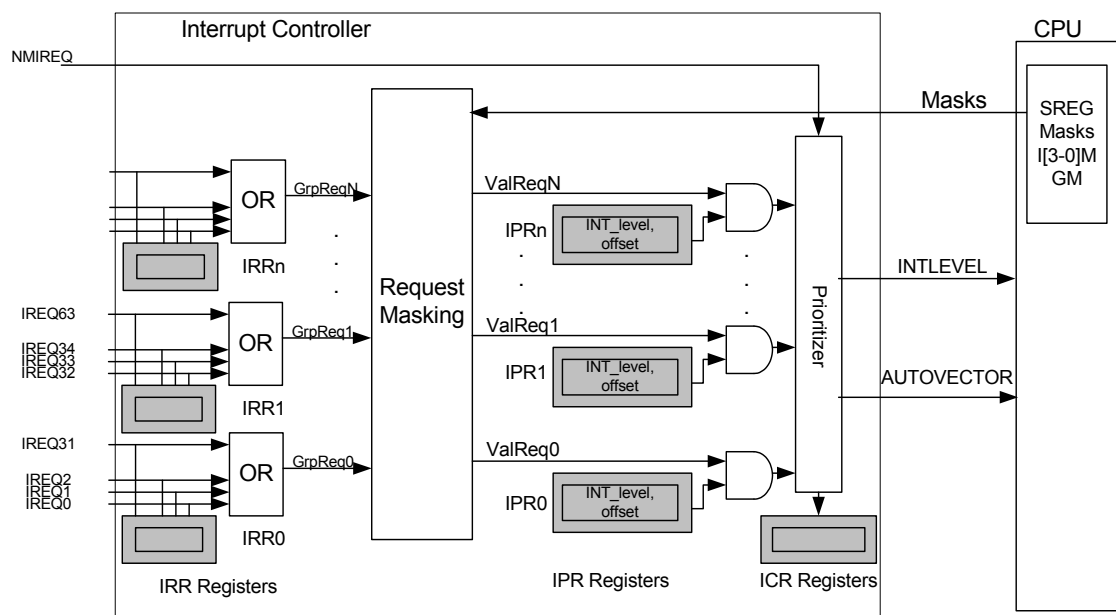

12.4 Product Dependencies

In order to use this module, other parts of the system must be configured correctly, as described below.

12.4.1 Power Management

If the CPU enters a sleep mode that disables CLK_SYNC, the INTC will stop functioning and resume operation after the system wakes up from sleep mode.

12.4.2 Clocks

The clock for the INTC bus interface (CLK_INTC) is generated by the Power Manager. This clock is enabled at reset, and can be disabled in the Power Manager.

The INTC sampling logic runs on a clock which is stopped in any of the sleep modes where the system RC oscillator is not running. This clock is referred to as CLK_SYNC. This clock is enabled at reset, and only turned off in sleep modes where the system RC oscillator is stopped.

12.4.3 Debug Operation

When an external debugger forces the CPU into debug mode, the INTC continues normal operation.

12.5 Functional Description

All of the incoming interrupt requests (IREQs) are sampled into the corresponding Interrupt Request Register (IRR). The IRRs must be accessed to identify which IREQ within a group that is active. If several IREQs within the same group are active, the interrupt service routine must prioritize between them. All of the input lines in each group are logically ORed together to form the GrpReqN lines, indicating if there is a pending interrupt in the corresponding group.

The Request Masking hardware maps each of the GrpReq lines to a priority level from INT0 to INT3 by associating each group with the Interrupt Level (INTLEVEL) field in the corresponding

Interrupt Priority Register (IPR). The GrpReq inputs are then masked by the mask bits from the CPU status register. Any interrupt group that has a pending interrupt of a priority level that is not masked by the CPU status register, gets its corresponding ValReq line asserted.

Masking of the interrupt requests is done based on five interrupt mask bits of the CPU status register, namely Interrupt Level 3 Mask (I3M) to Interrupt Level 0 Mask (I0M), and Global Interrupt Mask (GM). An interrupt request is masked if either the GM or the corresponding interrupt level mask bit is set.

The Prioritizer hardware uses the ValReq lines and the INTLEVEL field in the IPRs to select the pending interrupt of the highest priority. If an NMI interrupt request is pending, it automatically gets the highest priority of any pending interrupt. If several interrupt groups of the highest pending interrupt level have pending interrupts, the interrupt group with the lowest number is selected.

The INTLEVEL and handler autovector offset (AUTOVECTOR) of the selected interrupt are transmitted to the CPU for interrupt handling and context switching. The CPU does not need to know which interrupt is requesting handling, but only the level and the offset of the handler address. The IRR registers contain the interrupt request lines of the groups and can be read via user interface registers for checking which interrupts of the group are actually active.

The delay through the INTC from the peripheral interrupt request is set until the interrupt request to the CPU is set is three cycles of CLK_SYNC.

12.5.1 Non-Maskable Interrupts

A NMI request has priority over all other interrupt requests. NMI has a dedicated exception vector address defined by the AVR32 architecture, so AUTOVECTOR is undefined when INTLEVEL indicates that an NMI is pending.

12.5.2 CPU Response

When the CPU receives an interrupt request it checks if any other exceptions are pending. If no exceptions of higher priority are pending, interrupt handling is initiated. When initiating interrupt handling, the corresponding interrupt mask bit is set automatically for this and lower levels in status register. E.g, if an interrupt of level 3 is approved for handling, the interrupt mask bits I3M, I2M, I1M, and I0M are set in status register. If an interrupt of level 1 is approved, the masking bits I1M and I0M are set in status register. The handler address is calculated by logical OR of the AUTOVECTOR to the CPU system register Exception Vector Base Address (EVBA). The CPU will then jump to the calculated address and start executing the interrupt handler.

Setting the interrupt mask bits prevents the interrupts from the same and lower levels to be passed through the interrupt controller. Setting of the same level mask bit prevents also multiple requests of the same interrupt to happen.

It is the responsibility of the handler software to clear the interrupt request that caused the interrupt before returning from the interrupt handler. If the conditions that caused the interrupt are not cleared, the interrupt request remains active.

12.5.3 Clearing an Interrupt Request

Clearing of the interrupt request is done by writing to registers in the corresponding peripheral module, which then clears the corresponding NMIREQ/IREQ signal.

The recommended way of clearing an interrupt request is a store operation to the controlling peripheral register, followed by a dummy load operation from the same register. This causes a

pipeline stall, which prevents the interrupt from accidentally re-triggering in case the handler is exited and the interrupt mask is cleared before the interrupt request is cleared.

12.6 User Interface

Table 12-1. INTC Register Memory Map

| Offset | Register | Register Name | Access | Reset |
|--------|--------------------------------|---------------|------------|------------|
| 0x000 | Interrupt Priority Register 0 | IPR0 | Read/Write | 0x00000000 |
| 0x004 | Interrupt Priority Register 1 | IPR1 | Read/Write | 0x00000000 |
| ... | ... | ... | ... | ... |
| 0x0FC | Interrupt Priority Register 63 | IPR63 | Read/Write | 0x00000000 |
| 0x100 | Interrupt Request Register 0 | IRR0 | Read-only | N/A |
| 0x104 | Interrupt Request Register 1 | IRR1 | Read-only | N/A |
| ... | ... | ... | ... | ... |
| 0x1FC | Interrupt Request Register 63 | IRR63 | Read-only | N/A |
| 0x200 | Interrupt Cause Register 3 | ICR3 | Read-only | N/A |
| 0x204 | Interrupt Cause Register 2 | ICR2 | Read-only | N/A |
| 0x208 | Interrupt Cause Register 1 | ICR1 | Read-only | N/A |
| 0x20C | Interrupt Cause Register 0 | ICR0 | Read-only | N/A |

12.6.1 Interrupt Priority Registers

Name: IPR0...IPR63
Access Type: Read/Write
Offset: 0x000 - 0x0FC
Reset Value: 0x00000000

| | | | | | | | |
|-----------------|----|------------------|----|----|----|----|----|
| 31 | 30 | 29 | 28 | 27 | 26 | 25 | 24 |
| INTLEVEL | | - | - | - | - | - | - |
| 23 | 22 | 21 | 20 | 19 | 18 | 17 | 16 |
| - | - | - | - | - | - | - | - |
| 15 | 14 | 13 | 12 | 11 | 10 | 9 | 8 |
| - | - | AUTOVECTOR[13:8] | | | | | |
| 7 | 6 | 5 | 4 | 3 | 2 | 1 | 0 |
| AUTOVECTOR[7:0] | | | | | | | |

- INTLEVEL: Interrupt Level**

Indicates the EVBA-relative offset of the interrupt handler of the corresponding group:

00: INT0: Lowest priority

01: INT1

10: INT2

11: INT3: Highest priority

- AUTOVECTOR: Autovector Address**

Handler offset is used to give the address of the interrupt handler. The least significant bit should be written to zero to give halfword alignment.

12.6.2 Interrupt Request Registers

Name: IRR0...IRR63
Access Type: Read-only
Offset: 0x0FF - 0x1FC
Reset Value: N/A

| | | | | | | | |
|--------------|--------------|--------------|--------------|--------------|--------------|--------------|--------------|
| 31 | 30 | 29 | 28 | 27 | 26 | 25 | 24 |
| IRR[32*x+31] | IRR[32*x+30] | IRR[32*x+29] | IRR[32*x+28] | IRR[32*x+27] | IRR[32*x+26] | IRR[32*x+25] | IRR[32*x+24] |
| 23 | 22 | 21 | 20 | 19 | 18 | 17 | 16 |
| IRR[32*x+23] | IRR[32*x+22] | IRR[32*x+21] | IRR[32*x+20] | IRR[32*x+19] | IRR[32*x+18] | IRR[32*x+17] | IRR[32*x+16] |
| 15 | 14 | 13 | 12 | 11 | 10 | 9 | 8 |
| IRR[32*x+15] | IRR[32*x+14] | IRR[32*x+13] | IRR[32*x+12] | IRR[32*x+11] | IRR[32*x+10] | IRR[32*x+9] | IRR[32*x+8] |
| 7 | 6 | 5 | 4 | 3 | 2 | 1 | 0 |
| IRR[32*x+7] | IRR[32*x+6] | IRR[32*x+5] | IRR[32*x+4] | IRR[32*x+3] | IRR[32*x+2] | IRR[32*x+1] | IRR[32*x+0] |

- IRR: Interrupt Request line**

This bit is cleared when no interrupt request is pending on this input request line.

This bit is set when an interrupt request is pending on this input request line.

There are 64 IRRs, one for each group. Each IRR has 32 bits, one for each possible interrupt request, for a total of 2048 possible input lines. The IRRs are read by the software interrupt handler in order to determine which interrupt request is pending. The IRRs are sampled continuously, and are read-only.

12.6.3 Interrupt Cause Registers

Name: ICR0...ICR3

Access Type: Read-only

Offset: 0x200 - 0x20C

Reset Value: N/A

| | | | | | | | | |
|----|----|-------|----|----|----|----|----|--|
| 31 | 30 | 29 | 28 | 27 | 26 | 25 | 24 | |
| - | - | - | - | - | - | - | - | |
| 23 | 22 | 21 | 20 | 19 | 18 | 17 | 16 | |
| - | - | - | - | - | - | - | - | |
| 15 | 14 | 13 | 12 | 11 | 10 | 9 | 8 | |
| - | - | - | - | - | - | - | - | |
| 7 | 6 | 5 | 4 | 3 | 2 | 1 | 0 | |
| - | - | CAUSE | | | | | | |

- **CAUSE: Interrupt Group Causing Interrupt of Priority n**

ICRn identifies the group with the highest priority that has a pending interrupt of level n. This value is only defined when at least one interrupt of level n is pending.

12.7 Interrupt Request Signal Map

The various modules may output Interrupt request signals. These signals are routed to the Interrupt Controller (INTC), described in a later chapter. The Interrupt Controller supports up to 64 groups of interrupt requests. Each group can have up to 32 interrupt request signals. All interrupt signals in the same group share the same autovector address and priority level. Refer to the documentation for the individual submodules for a description of the semantics of the different interrupt requests.

The interrupt request signals are connected to the INTC as follows.

Table 12-2. Interrupt Request Signal Map

| Group | Line | Module | Signal |
|-------|------|---|----------------|
| 0 | 0 | AVR32 UC CPU with optional MPU and optional OCD | SYSREG COMPARE |
| 1 | 0 | External Interrupt Controller | EIC 0 |
| | 1 | External Interrupt Controller | EIC 1 |
| | 2 | External Interrupt Controller | EIC 2 |
| | 3 | External Interrupt Controller | EIC 3 |
| | 4 | External Interrupt Controller | EIC 4 |
| | 5 | External Interrupt Controller | EIC 5 |
| | 6 | External Interrupt Controller | EIC 6 |
| | 7 | External Interrupt Controller | EIC 7 |
| | 8 | Real Time Counter | RTC |
| | 9 | Power Manager | PM |
| 2 | 0 | General Purpose Input/Output Controller | GPIO 0 |
| | 1 | General Purpose Input/Output Controller | GPIO 1 |
| | 2 | General Purpose Input/Output Controller | GPIO 2 |
| | 3 | General Purpose Input/Output Controller | GPIO 3 |
| | 4 | General Purpose Input/Output Controller | GPIO 4 |
| | 5 | General Purpose Input/Output Controller | GPIO 5 |
| 3 | 0 | Peripheral DMA Controller | PDCA 0 |
| | 1 | Peripheral DMA Controller | PDCA 1 |
| | 2 | Peripheral DMA Controller | PDCA 2 |
| | 3 | Peripheral DMA Controller | PDCA 3 |
| | 4 | Peripheral DMA Controller | PDCA 4 |
| | 5 | Peripheral DMA Controller | PDCA 5 |
| | 6 | Peripheral DMA Controller | PDCA 6 |
| 4 | 0 | Flash Controller | FLASHC |
| 5 | 0 | Universal Synchronous/Asynchronous Receiver/Transmitter | USART0 |

Table 12-2. Interrupt Request Signal Map

| | | | |
|----|---|---|--------|
| 6 | 0 | Universal Synchronous/Asynchronous Receiver/Transmitter | USART1 |
| 7 | 0 | Universal Synchronous/Asynchronous Receiver/Transmitter | USART2 |
| 9 | 0 | Serial Peripheral Interface | SPI |
| 11 | 0 | Two-wire Interface | TWI |
| 12 | 0 | Pulse Width Modulation Controller | PWM |
| 13 | 0 | Synchronous Serial Controller | SSC |
| 14 | 0 | Timer/Counter | TC0 |
| | 1 | Timer/Counter | TC1 |
| | 2 | Timer/Counter | TC2 |
| 15 | 0 | Analog to Digital Converter | ADC |
| 17 | 0 | USB 2.0 Interface | USBB |
| 18 | 0 | Audio Bitstream DAC | ABDAC |

13. External Interrupt Controller (EIC)

Rev: 2.3.1.0

13.1 Features

- **Dedicated interrupt request for each interrupt**
- **Individually maskable interrupts**
- **Interrupt on rising or falling edge**
- **Interrupt on high or low level**
- **Asynchronous interrupts for sleep modes without clock**
- **Filtering of interrupt lines**
- **Maskable NMI interrupt**
- **Keypad scan support**

13.2 Overview

The External Interrupt Controller (EIC) allows pins to be configured as external interrupts. Each external interrupt has its own interrupt request and can be individually masked. Each external interrupt can generate an interrupt on rising or falling edge, or high or low level. Every interrupt input has a configurable filter to remove spikes from the interrupt source. Every interrupt pin can also be configured to be asynchronous in order to wake up the part from sleep modes where the CLK_SYNC clock has been disabled.

A Non-Maskable Interrupt (NMI) is also supported. This has the same properties as the other external interrupts, but is connected to the NMI request of the CPU, enabling it to interrupt any other interrupt mode.

The EIC can wake up the part from sleep modes without triggering an interrupt. In this mode, code execution starts from the instruction following the sleep instruction.

The External Interrupt Controller has support for keypad scanning for keypads laid out in rows and columns. Columns are driven by a separate set of scanning outputs, while rows are sensed by the external interrupt lines. The pressed key will trigger an interrupt, which can be identified through the user registers of the module.

13.3 Block Diagram

Figure 13-1. EIC Block Diagram

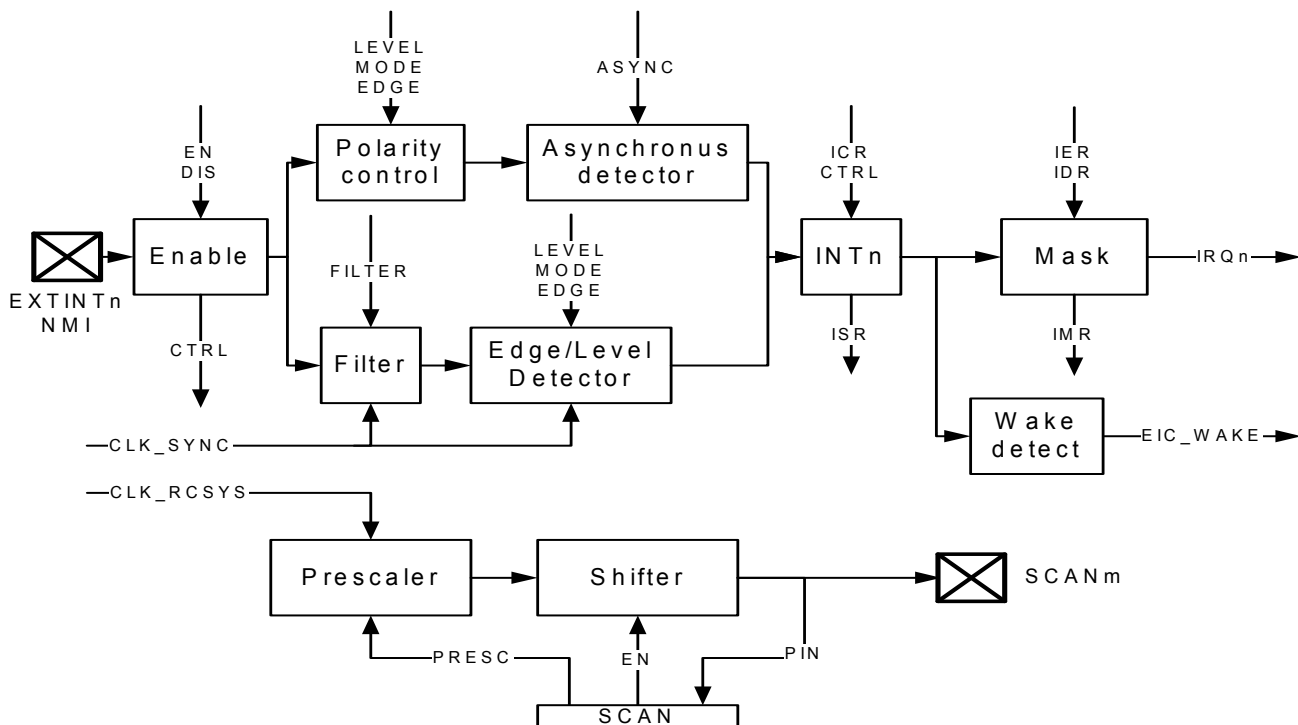

13.4 I/O Lines Description

Table 13-1. I/O Lines Description

| Pin Name | Pin Description | Type |
|----------|------------------------|--------|
| NMI | Non-Maskable Interrupt | Input |
| EXTINTn | External Interrupt | Input |
| SCANm | Keypad scan pin m | Output |

13.5 Product Dependencies

In order to use this module, other parts of the system must be configured correctly, as described below.

13.5.1 I/O Lines

The external interrupt pins (EXTINTn and NMI) are multiplexed with I/O lines. To generate an external interrupt from an external source the source pin must be configured as an input pins by the I/O Controller. It is also possible to trigger the interrupt by driving these pins from registers in the I/O Controller, or another peripheral output connected to the same pin.

13.5.2 Power Management

All interrupts are available in all sleep modes as long as the EIC module is powered. However, in sleep modes where CLK_SYNC is stopped, the interrupt must be configured to asynchronous mode.

13.5.3 Clocks

The clock for the EIC bus interface (CLK_EIC) is generated by the Power Manager. This clock is enabled at reset, and can be disabled in the Power Manager.

The filter and synchronous edge/level detector runs on a clock which is stopped in any of the sleep modes where the system RC oscillator is not running. This clock is referred to as CLK_SYNC. Refer to the Module Configuration section at the end of this chapter for details.

The Keypad scan function operates on the system RC oscillator clock CLK_RCSYS.

13.5.4 Interrupts

The external interrupt request lines are connected to the interrupt controller. Using the external interrupts requires the interrupt controller to be programmed first.

Using the Non-Maskable Interrupt does not require the interrupt controller to be programmed.

13.5.5 Debug Operation

The EIC is frozen during debug operation, unless the OCD system keeps peripherals running during debug operation.

13.6 Functional Description

13.6.1 External Interrupts

The external interrupts are not enabled by default, allowing the proper interrupt vectors to be set up by the CPU before the interrupts are enabled.

Each external interrupt INT_n can be configured to produce an interrupt on rising or falling edge, or high or low level. External interrupts are configured by the MODE, EDGE, and LEVEL registers. Each interrupt *n* has a bit INT_n in each of these registers. Writing a zero to the INT_n bit in the MODE register enables edge triggered interrupts, while writing a one to the bit enables level triggered interrupts.

If INT_n is configured as an edge triggered interrupt, writing a zero to the INT_n bit in the EDGE register will cause the interrupt to be triggered on a falling edge on EXTINT_n, while writing a one to the bit will cause the interrupt to be triggered on a rising edge on EXTINT_n.

If INT_n is configured as a level triggered interrupt, writing a zero to the INT_n bit in the LEVEL register will cause the interrupt to be triggered on a low level on EXTINT_n, while writing a one to the bit will cause the interrupt to be triggered on a high level on EXTINT_n.

Each interrupt has a corresponding bit in each of the interrupt control and status registers. Writing a one to the INT_n bit in the Interrupt Enable Register (IER) enables the external interrupt from pin EXTINT_n to propagate from the EIC to the interrupt controller, while writing a one to INT_n bit in the Interrupt Disable Register (IDR) disables this propagation. The Interrupt Mask Register (IMR) can be read to check which interrupts are enabled. When an interrupt triggers, the corresponding bit in the Interrupt Status Register (ISR) will be set. This bit remains set until a one is written to the corresponding bit in the Interrupt Clear Register (ICR) or the interrupt is disabled.

Writing a one to the INT_n bit in the Enable Register (EN) enables the external interrupt on pin EXTINT_n, while writing a one to INT_n bit in the Disable Register (DIS) disables the external interrupt. The Control Register (CTRL) can be read to check which interrupts are enabled. If a bit in the CTRL register is set, but the corresponding bit in IMR is not set, an interrupt will not propa-

gate to the interrupt controller. However, the corresponding bit in ISR will be set, and EIC_WAKE will be set.

If the CTRL.INTn bit is zero, then the corresponding bit in ISR will always be zero. Disabling an external interrupt by writing to the DIS.INTn bit will clear the corresponding bit in ISR.

13.6.2 Synchronization and Filtering of External Interrupts

In synchronous mode the pin value of the EXTINTn pin is synchronized to CLK_SYNC, so spikes shorter than one CLK_SYNC cycle are not guaranteed to produce an interrupt. The synchronization of the EXTINTn to CLK_SYNC will delay the propagation of the interrupt to the interrupt controller by two cycles of CLK_SYNC, see [Figure 13-2 on page 101](#) and [Figure 13-3 on page 101](#) for examples (FILTER off).

It is also possible to apply a filter on EXTINTn by writing a one to INTn bit in the FILTER register. This filter is a majority voter, if the condition for an interrupt is true for more than one of the latest three cycles of CLK_SYNC the interrupt will be set. This will additionally delay the propagation of the interrupt to the interrupt controller by one or two cycles of CLK_SYNC, see [Figure 13-2 on page 101](#) and [Figure 13-3 on page 101](#) for examples (FILTER on).

Figure 13-2. Timing Diagram, Synchronous Interrupts, High Level or Rising Edge

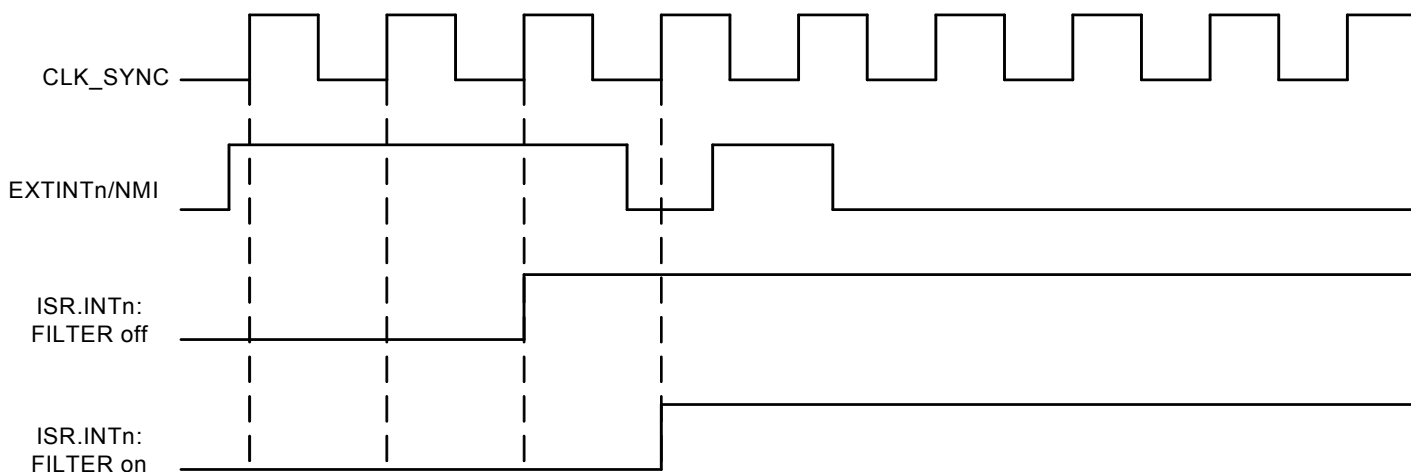
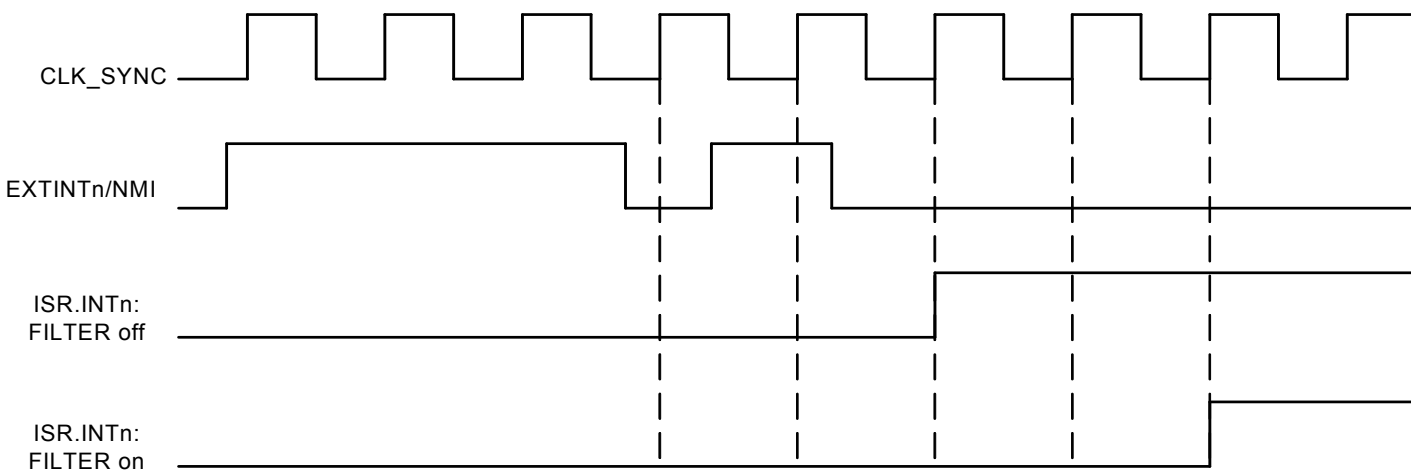

Figure 13-3. Timing Diagram, Synchronous Interrupts, Low Level or Falling Edge



13.6.3 Non-Maskable Interrupt

The NMI supports the same features as the external interrupts, and is accessed through the same registers. The description in [Section 13.6.1](#) should be followed, accessing the NMI bit instead of the INTn bits.

The NMI is non-maskable within the CPU in the sense that it can interrupt any other execution mode. Still, as for the other external interrupts, the actual NMI input can be enabled and disabled by accessing the registers in the EIC.

13.6.4 Asynchronous Interrupts

Each external interrupt can be made asynchronous by writing a one to INTn in the ASYNC register. This will route the interrupt signal through the asynchronous path of the module. All edge interrupts will be interpreted as level interrupts and the filter is disabled. If an interrupt is configured as edge triggered interrupt in asynchronous mode, a zero in EDGE.INTn will be interpreted as low level, and a one in EDGE.INTn will be interpreted as high level.

EIC_WAKE will be set immediately after the source triggers the interrupt, while the corresponding bit in ISR and the interrupt to the interrupt controller will be set on the next rising edge of CLK_SYNC. Please refer to [Figure 13-4 on page 102](#) for details.

When CLK_SYNC is stopped only asynchronous interrupts remain active, and any short spike on this interrupt will wake up the device. EIC_WAKE will restart CLK_SYNC and ISR will be updated on the first rising edge of CLK_SYNC.

Figure 13-4. Timing Diagram, Asynchronous Interrupts

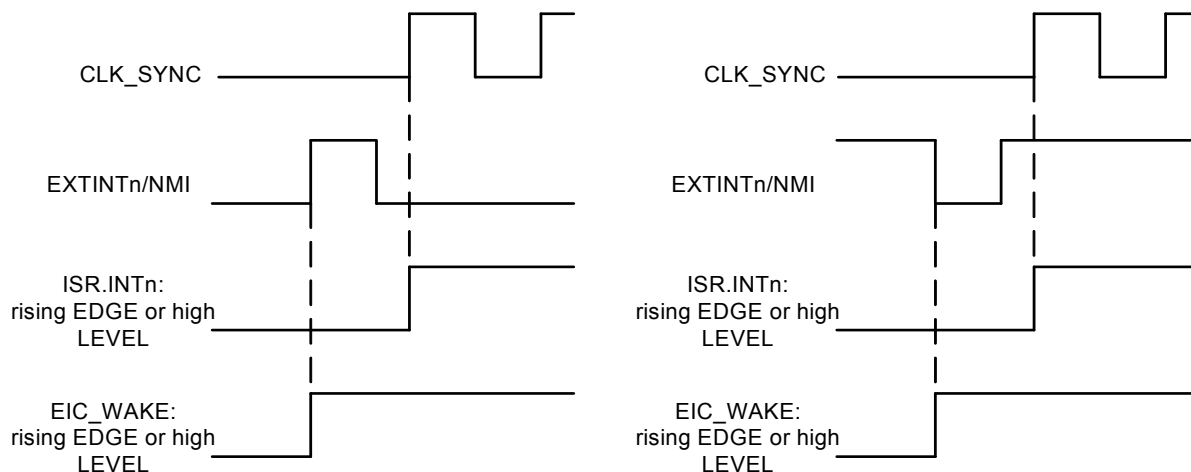

13.6.5 Wakeup

The external interrupts can be used to wake up the part from sleep modes. The wakeup can be interpreted in two ways. If the corresponding bit in IMR is one, then the execution starts at the interrupt handler for this interrupt. If the bit in IMR is zero, then the execution starts from the next instruction after the sleep instruction.

13.6.6 Keypad scan support

The External Interrupt Controller also includes support for keypad scanning. The keypad scan feature is compatible with keypads organized as rows and columns, where a row is shorted against a column when a key is pressed.

The rows should be connected to the external interrupt pins with pull-ups enabled in the I/O Controller. These external interrupts should be enabled as low level or falling edge interrupts. The columns should be connected to the available scan pins. The I/O Controller must be configured to let the required scan pins be controlled by the EIC. Unused external interrupt or scan pins can be left controlled by the I/O Controller or other peripherals.

The Keypad Scan function is enabled by writing SCAN.EN to 1, which starts the keypad scan counter. The SCAN outputs are tri-stated, except SCAN[0], which is driven to zero. After $2^{(\text{SCAN.PRESC}+1)}$ RC clock cycles this pattern is left shifted, so that SCAN[1] is driven to zero while the other outputs are tri-stated. This sequence repeats infinitely, wrapping from the most significant SCAN pin to SCAN[0].

When a key is pressed, the pulled-up row is driven to zero by the column, and an external interrupt triggers. The scanning stops, and the software can then identify the key pressed by the interrupt status register and the SCAN.PINS value.

The scanning stops whenever there is an active interrupt request from the EIC to the CPU. When the CPU clears the interrupt flags, scanning resumes.

13.7 User Interface

Table 13-2. EIC Register Memory Map

| Offset | Register | Register Name | Access | Reset |
|--------|----------------------------|---------------|------------|------------|
| 0x000 | Interrupt Enable Register | IER | Write-only | 0x00000000 |
| 0x004 | Interrupt Disable Register | IDR | Write-only | 0x00000000 |
| 0x008 | Interrupt Mask Register | IMR | Read-only | 0x00000000 |
| 0x00C | Interrupt Status Register | ISR | Read-only | 0x00000000 |
| 0x010 | Interrupt Clear Register | ICR | Write-only | 0x00000000 |
| 0x014 | Mode Register | MODE | Read/Write | 0x00000000 |
| 0x018 | Edge Register | EDGE | Read/Write | 0x00000000 |
| 0x01C | Level Register | LEVEL | Read/Write | 0x00000000 |
| 0x020 | Filter Register | FILTER | Read/Write | 0x00000000 |
| 0x024 | Test Register | TEST | Read/Write | 0x00000000 |
| 0x028 | Asynchronous Register | ASYNC | Read/Write | 0x00000000 |
| 0x2C | Scan Register | SCAN | Read/Write | 0x00000000 |
| 0x030 | Enable Register | EN | Write-only | 0x00000000 |
| 0x034 | Disable Register | DIS | Write-only | 0x00000000 |
| 0x038 | Control Register | CTRL | Read-only | 0x00000000 |

13.7.1 Interrupt Enable Register

Name: IER
Access Type: Write-only
Offset: 0x000
Reset Value: 0x00000000

| | | | | | | | |
|------|------|------|------|------|------|------|------|
| 31 | 30 | 29 | 28 | 27 | 26 | 25 | 24 |
| - | - | - | - | - | - | - | - |
| 23 | 22 | 21 | 20 | 19 | 18 | 17 | 16 |
| - | - | - | - | - | - | - | - |
| 15 | 14 | 13 | 12 | 11 | 10 | 9 | 8 |
| - | - | - | - | - | - | - | NMI |
| 7 | 6 | 5 | 4 | 3 | 2 | 1 | 0 |
| INT7 | INT6 | INT5 | INT4 | INT3 | INT2 | INT1 | INT0 |

- **INTn: External Interrupt n**
 Writing a zero to this bit has no effect.
 Writing a one to this bit will set the corresponding bit in IMR.
- **NMI: Non-Maskable Interrupt**
 Writing a zero to this bit has no effect.
 Writing a one to this bit will set the corresponding bit in IMR.

13.7.2 Interrupt Disable Register

Name: IDR
Access Type: Write-only
Offset: 0x004
Reset Value: 0x00000000

| | | | | | | | |
|------|------|------|------|------|------|------|------|
| 31 | 30 | 29 | 28 | 27 | 26 | 25 | 24 |
| - | - | - | - | - | - | - | - |
| 23 | 22 | 21 | 20 | 19 | 18 | 17 | 16 |
| - | - | - | - | - | - | - | - |
| 15 | 14 | 13 | 12 | 11 | 10 | 9 | 8 |
| - | - | - | - | - | - | - | NMI |
| 7 | 6 | 5 | 4 | 3 | 2 | 1 | 0 |
| INT7 | INT6 | INT5 | INT4 | INT3 | INT2 | INT1 | INT0 |

- INTn: External Interrupt n**
 Writing a zero to this bit has no effect.
 Writing a one to this bit will clear the corresponding bit in IMR.
- NMI: Non-Maskable Interrupt**
 Writing a zero to this bit has no effect.
 Writing a one to this bit will clear the corresponding bit in IMR.

13.7.3 Interrupt Mask Register

Name: IMR
Access Type: Read-only
Offset: 0x008
Reset Value: 0x00000000

| | | | | | | | |
|------|------|------|------|------|------|------|------|
| 31 | 30 | 29 | 28 | 27 | 26 | 25 | 24 |
| - | - | - | - | - | - | - | - |
| 23 | 22 | 21 | 20 | 19 | 18 | 17 | 16 |
| - | - | - | - | - | - | - | - |
| 15 | 14 | 13 | 12 | 11 | 10 | 9 | 8 |
| - | - | - | - | - | - | - | NMI |
| 7 | 6 | 5 | 4 | 3 | 2 | 1 | 0 |
| INT7 | INT6 | INT5 | INT4 | INT3 | INT2 | INT1 | INT0 |

- **INTn: External Interrupt n**
 0: The corresponding interrupt is disabled.
 1: The corresponding interrupt is enabled.
 This bit is cleared when the corresponding bit in IDR is written to one.
 This bit is set when the corresponding bit in IER is written to one.
- **NMI: Non-Maskable Interrupt**
 0: The Non-Maskable Interrupt is disabled.
 1: The Non-Maskable Interrupt is enabled.
 This bit is cleared when the corresponding bit in IDR is written to one.
 This bit is set when the corresponding bit in IER is written to one.

13.7.4 Interrupt Status Register

Name: ISR
Access Type: Read-only
Offset: 0x00C
Reset Value: 0x00000000

| | | | | | | | |
|------|------|------|------|------|------|------|------|
| 31 | 30 | 29 | 28 | 27 | 26 | 25 | 24 |
| - | - | - | - | - | - | - | - |
| 23 | 22 | 21 | 20 | 19 | 18 | 17 | 16 |
| - | - | - | - | - | - | - | - |
| 15 | 14 | 13 | 12 | 11 | 10 | 9 | 8 |
| - | - | - | - | - | - | - | NMI |
| 7 | 6 | 5 | 4 | 3 | 2 | 1 | 0 |
| INT7 | INT6 | INT5 | INT4 | INT3 | INT2 | INT1 | INT0 |

- INTn: External Interrupt n**
 0: An interrupt event has not occurred
 1: An interrupt event has occurred
 This bit is cleared by writing a one to the corresponding bit in ICR.
- NMI: Non-Maskable Interrupt**
 0: An interrupt event has not occurred
 1: An interrupt event has occurred
 This bit is cleared by writing a one to the corresponding bit in ICR.

13.7.5 Interrupt Clear Register

Name: ICR
Access Type: Write-only
Offset: 0x010
Reset Value: 0x00000000

| | | | | | | | |
|------|------|------|------|------|------|------|------|
| 31 | 30 | 29 | 28 | 27 | 26 | 25 | 24 |
| - | - | - | - | - | - | - | - |
| 23 | 22 | 21 | 20 | 19 | 18 | 17 | 16 |
| - | - | - | - | - | - | - | - |
| 15 | 14 | 13 | 12 | 11 | 10 | 9 | 8 |
| - | - | - | - | - | - | - | NMI |
| 7 | 6 | 5 | 4 | 3 | 2 | 1 | 0 |
| INT7 | INT6 | INT5 | INT4 | INT3 | INT2 | INT1 | INT0 |

- INTn: External Interrupt n**
 Writing a zero to this bit has no effect.
 Writing a one to this bit will clear the corresponding bit in ISR.
- NMI: Non-Maskable Interrupt**
 Writing a zero to this bit has no effect.
 Writing a one to this bit will clear the corresponding bit in ISR.

13.7.6 Mode Register

Name: MODE
Access Type: Read/Write
Offset: 0x014
Reset Value: 0x00000000

| | | | | | | | |
|------|------|------|------|------|------|------|------|
| 31 | 30 | 29 | 28 | 27 | 26 | 25 | 24 |
| - | - | - | - | - | - | - | - |
| 23 | 22 | 21 | 20 | 19 | 18 | 17 | 16 |
| - | - | - | - | - | - | - | - |
| 15 | 14 | 13 | 12 | 11 | 10 | 9 | 8 |
| - | - | - | - | - | - | - | NMI |
| 7 | 6 | 5 | 4 | 3 | 2 | 1 | 0 |
| INT7 | INT6 | INT5 | INT4 | INT3 | INT2 | INT1 | INT0 |

- INTn: External Interrupt n**
 0: The external interrupt is edge triggered.
 1: The external interrupt is level triggered.
- NMI: Non-Maskable Interrupt**
 0: The Non-Maskable Interrupt is edge triggered.
 1: The Non-Maskable Interrupt is level triggered.

13.7.7 Edge Register

Name: EDGE
Access Type: Read/Write
Offset: 0x018
Reset Value: 0x00000000

| | | | | | | | |
|------|------|------|------|------|------|------|------|
| 31 | 30 | 29 | 28 | 27 | 26 | 25 | 24 |
| - | - | - | - | - | - | - | - |
| 23 | 22 | 21 | 20 | 19 | 18 | 17 | 16 |
| - | - | - | - | - | - | - | - |
| 15 | 14 | 13 | 12 | 11 | 10 | 9 | 8 |
| - | - | - | - | - | - | - | NMI |
| 7 | 6 | 5 | 4 | 3 | 2 | 1 | 0 |
| INT7 | INT6 | INT5 | INT4 | INT3 | INT2 | INT1 | INT0 |

- INTn: External Interrupt n**
 0: The external interrupt triggers on falling edge.
 1: The external interrupt triggers on rising edge.
- NMI: Non-Maskable Interrupt**
 0: The Non-Maskable Interrupt triggers on falling edge.
 1: The Non-Maskable Interrupt triggers on rising edge.

13.7.8 Level Register

Name: LEVEL
Access Type: Read/Write
Offset: 0x01C
Reset Value: 0x00000000

| | | | | | | | |
|------|------|------|------|------|------|------|------|
| 31 | 30 | 29 | 28 | 27 | 26 | 25 | 24 |
| - | - | - | - | - | - | - | - |
| 23 | 22 | 21 | 20 | 19 | 18 | 17 | 16 |
| - | - | - | - | - | - | - | - |
| 15 | 14 | 13 | 12 | 11 | 10 | 9 | 8 |
| - | - | - | - | - | - | - | NMI |
| 7 | 6 | 5 | 4 | 3 | 2 | 1 | 0 |
| INT7 | INT6 | INT5 | INT4 | INT3 | INT2 | INT1 | INT0 |

- INTn: External Interrupt n**
 0: The external interrupt triggers on low level.
 1: The external interrupt triggers on high level.
- NMI: Non-Maskable Interrupt**
 0: The Non-Maskable Interrupt triggers on low level.
 1: The Non-Maskable Interrupt triggers on high level.

13.7.9 Filter Register

Name: FILTER
Access Type: Read/Write
Offset: 0x020
Reset Value: 0x00000000

| | | | | | | | |
|------|------|------|------|------|------|------|------|
| 31 | 30 | 29 | 28 | 27 | 26 | 25 | 24 |
| - | - | - | - | - | - | - | - |
| 23 | 22 | 21 | 20 | 19 | 18 | 17 | 16 |
| - | - | - | - | - | - | - | - |
| 15 | 14 | 13 | 12 | 11 | 10 | 9 | 8 |
| - | - | - | - | - | - | - | NMI |
| 7 | 6 | 5 | 4 | 3 | 2 | 1 | 0 |
| INT7 | INT6 | INT5 | INT4 | INT3 | INT2 | INT1 | INT0 |

- INTn: External Interrupt n**
 0: The external interrupt is not filtered.
 1: The external interrupt is filtered.
- NMI: Non-Maskable Interrupt**
 0: The Non-Maskable Interrupt is not filtered.
 1: The Non-Maskable Interrupt is filtered.

13.7.10 Test Register

Name: TEST
Access Type: Read/Write
Offset: 0x024
Reset Value: 0x00000000

| | | | | | | | |
|------|------|------|------|------|------|------|------|
| 31 | 30 | 29 | 28 | 27 | 26 | 25 | 24 |
| - | - | - | - | - | - | - | - |
| 23 | 22 | 21 | 20 | 19 | 18 | 17 | 16 |
| - | - | - | - | - | - | - | - |
| 15 | 14 | 13 | 12 | 11 | 10 | 9 | 8 |
| - | - | - | - | - | - | - | NMI |
| 7 | 6 | 5 | 4 | 3 | 2 | 1 | 0 |
| INT7 | INT6 | INT5 | INT4 | INT3 | INT2 | INT1 | INT0 |

- TESTEN: Test Enable**
 0: This bit disables external interrupt test mode.
 1: This bit enables external interrupt test mode.
- INTn: External Interrupt n**
 If TESTEN is 1, the value written to this bit will be the value to the interrupt detector and the value on the pad will be ignored.
- NMI: Non-Maskable Interrupt**
 If TESTEN is 1, the value written to this bit will be the value to the interrupt detector and the value on the pad will be ignored.

13.7.11 Asynchronous Register

Name: ASYNC
Access Type: Read/Write
Offset: 0x028
Reset Value: 0x00000000

| | | | | | | | |
|------|------|------|------|------|------|------|------|
| 31 | 30 | 29 | 28 | 27 | 26 | 25 | 24 |
| - | - | - | - | - | - | - | - |
| 23 | 22 | 21 | 20 | 19 | 18 | 17 | 16 |
| - | - | - | - | - | - | - | - |
| 15 | 14 | 13 | 12 | 11 | 10 | 9 | 8 |
| - | - | - | - | - | - | - | NMI |
| 7 | 6 | 5 | 4 | 3 | 2 | 1 | 0 |
| INT7 | INT6 | INT5 | INT4 | INT3 | INT2 | INT1 | INT0 |

- INTn: External Interrupt n**
 0: The external interrupt is synchronized to CLK_SYNC.
 1: The external interrupt is asynchronous.
- NMI: Non-Maskable Interrupt**
 0: The Non-Maskable Interrupt is synchronized to CLK_SYNC
 1: The Non-Maskable Interrupt is asynchronous.

13.7.12 Scan Register

Name: SCAN
Access Type: Read/Write
Offset: 0x2C
Reset Value: 0x0000000

| | | | | | | | |
|----|----|----|------------|----|----------|----|----|
| 31 | 30 | 29 | 28 | 27 | 26 | 25 | 24 |
| - | - | - | - | - | PIN[2:0] | | |
| 23 | 22 | 21 | 20 | 19 | 18 | 17 | 16 |
| - | - | - | - | - | - | - | - |
| 15 | 14 | 13 | 12 | 11 | 10 | 9 | 8 |
| - | - | - | PRESC[4:0] | | | | |
| 7 | 6 | 5 | 4 | 3 | 2 | 1 | 0 |
| - | - | - | - | - | - | - | EN |

- **EN**

0: Keypad scanning is disabled

1: Keypad scanning is enabled

- **PRESC**

Prescale select for the keypad scan rate:

$$\text{Scan rate} = 2^{(\text{SCAN.PRESC}+1)} T_{RC}$$

The RC clock period can be found in the Electrical Characteristics section.

- **PIN**

The index of the currently active scan pin. Writing to this bitfield has no effect.

13.7.13 Enable Register

Name: EN
Access Type: Write-only
Offset: 0x030
Reset Value: 0x00000000

| | | | | | | | |
|------|------|------|------|------|------|------|------|
| 31 | 30 | 29 | 28 | 27 | 26 | 25 | 24 |
| - | - | - | - | - | - | - | - |
| 23 | 22 | 21 | 20 | 19 | 18 | 17 | 16 |
| - | - | - | - | - | - | - | - |
| 15 | 14 | 13 | 12 | 11 | 10 | 9 | 8 |
| - | - | - | - | - | - | - | NMI |
| 7 | 6 | 5 | 4 | 3 | 2 | 1 | 0 |
| INT7 | INT6 | INT5 | INT4 | INT3 | INT2 | INT1 | INT0 |

- INTn: External Interrupt n**
 Writing a zero to this bit has no effect.
 Writing a one to this bit will enable the corresponding external interrupt.
- NMI: Non-Maskable Interrupt**
 Writing a zero to this bit has no effect.
 Writing a one to this bit will enable the Non-Maskable Interrupt.

13.7.14 Disable Register

Name: DIS
Access Type: Write-only
Offset: 0x034
Reset Value: 0x00000000

| | | | | | | | |
|------|------|------|------|------|------|------|------|
| 31 | 30 | 29 | 28 | 27 | 26 | 25 | 24 |
| - | - | - | - | - | - | - | - |
| 23 | 22 | 21 | 20 | 19 | 18 | 17 | 16 |
| - | - | - | - | - | - | - | - |
| 15 | 14 | 13 | 12 | 11 | 10 | 9 | 8 |
| - | - | - | - | - | - | - | NMI |
| 7 | 6 | 5 | 4 | 3 | 2 | 1 | 0 |
| INT7 | INT6 | INT5 | INT4 | INT3 | INT2 | INT1 | INT0 |

- INTn: External Interrupt n**
 Writing a zero to this bit has no effect.
 Writing a one to this bit will disable the corresponding external interrupt.
- NMI: Non-Maskable Interrupt**
 Writing a zero to this bit has no effect.
 Writing a one to this bit will disable the Non-Maskable Interrupt.

13.7.15 Control Register

Name: CTRL
Access Type: Read-only
Offset: 0x038
Reset Value: 0x00000000

| | | | | | | | |
|------|------|------|------|------|------|------|------|
| 31 | 30 | 29 | 28 | 27 | 26 | 25 | 24 |
| - | - | - | - | - | - | - | - |
| 23 | 22 | 21 | 20 | 19 | 18 | 17 | 16 |
| - | - | - | - | - | - | - | - |
| 15 | 14 | 13 | 12 | 11 | 10 | 9 | 8 |
| - | - | - | - | - | - | - | NMI |
| 7 | 6 | 5 | 4 | 3 | 2 | 1 | 0 |
| INT7 | INT6 | INT5 | INT4 | INT3 | INT2 | INT1 | INT0 |

- INTn: External Interrupt n**
 0: The corresponding external interrupt is disabled.
 1: The corresponding external interrupt is enabled.
- NMI: Non-Maskable Interrupt**
 0: The Non-Maskable Interrupt is disabled.
 1: The Non-Maskable Interrupt is enabled.

14. Flash Controller (FLASHC)

Rev: 2.1.2.4

14.1 Features

- Controls flash block with dual read ports allowing staggered reads.
- Supports 0 and 1 wait state bus access.
- Allows interleaved burst reads for systems with one wait state, outputting one 32-bit word per clock cycle.
- 32-bit HSB interface for reads from flash array and writes to page buffer.
- 32-bit PB interface for issuing commands to and configuration of the controller.
- 16 lock bits, each protecting a region consisting of (total number of pages in the flash block / 16) pages.
- Regions can be individually protected or unprotected.
- Additional protection of the Boot Loader pages.
- Supports reads and writes of general-purpose NVM bits.
- Supports reads and writes of additional NVM pages.
- Supports device protection through a security bit.
- Dedicated command for chip-erase, first erasing all on-chip volatile memories before erasing flash and clearing security bit.
- Interface to Power Manager for power-down of flash-blocks in sleep mode.
-

14.2 Overview

The flash controller (FLASHC) interfaces a flash block with the 32-bit internal High-Speed Bus (HSB). Performance for uncached systems with high clock-frequency and one wait state is increased by placing words with sequential addresses in alternating flash subblocks. Having one read interface per subblock allows them to be read in parallel. While data from one flash subblock is being output on the bus, the sequential address is being read from the other flash subblock and will be ready in the next clock cycle.

The controller also manages the programming, erasing, locking and unlocking sequences with dedicated commands.

14.3 Product dependencies

14.3.1 Power Manager

The FLASHC has two bus clocks connected: One High speed bus clock (CLK_FLASHC_HSB) and one Peripheral bus clock (CLK_FLASHC_PB). These clocks are generated by the Power manager. Both clocks are turned on by default, but the user has to ensure that CLK_FLASHC_HSB is not turned off before reading the flash or writing the pagebuffer and that CLK_FLASHC_PB is not turned off before accessing the FLASHC configuration and control registers.

14.3.2 Interrupt Controller

The FLASHC interrupt lines are connected to internal sources of the interrupt controller. Using FLASHC interrupts requires the interrupt controller to be programmed first.

14.4 Functional description

14.4.1 Bus interfaces

The FLASHC has two bus interfaces, one HSB interface for reads from the flash array and writes to the page buffer, and one Peripheral Bus (PB) interface for writing commands and control to and reading status from the controller.

14.4.2 Memory organization

To maximize performance for high clock-frequency systems, FLASHC interfaces to a flash block with two read ports. The flash block has several parameters, given by the design of the flash block. Refer to the “Memories” chapter for the device-specific values of the parameters.

- p pages (*FLASH_P*)
- w words in each page and in the page buffer (*FLASH_W*)
- pw words in total (*FLASH_PW*)
- f general-purpose fuse bits (*FLASH_F*)
- 1 security fuse bit
- 1 User Page

14.4.3 User page

The User page is an additional page, outside the regular flash array, that can be used to store various data, like calibration data and serial numbers. This page is not erased by regular chip erase. The User page can only be written and erased by proprietary commands. Read accesses to the User page is performed just as any other read access to the flash. The address map of the User page is given in [Figure 14-1](#).

14.4.4 Read operations

The FLASHC provides two different read modes:

- 0 wait state (0ws) for clock frequencies $<$ (access time of the flash plus the bus delay)
- 1 wait state (1ws) for clock frequencies $<$ (access time of the flash plus the bus delay)/2

Higher clock frequencies that would require more wait states are not supported by the flash controller.

The programmer can select the wait states required by writing to the FWS field in the Flash Control Register (FCR). It is the responsibility of the programmer to select a number of wait states compatible with the clock frequency and timing characteristics of the flash block.

In 0ws mode, only one of the two flash read ports is accessed. The other flash read port is idle. In 1ws mode, both flash read ports are active. One read port reading the addressed word, and the other reading the next sequential word.

If the clock frequency allows, the user should use 0ws mode, because this gives the lowest power consumption for low-frequency systems as only one flash read port is read. Using 1ws mode has a power/performance ratio approaching 0ws mode as the clock frequency approaches twice the max frequency of 0ws mode. Using two flash read ports use twice the power, but also give twice the performance.

The flash controller supports flash blocks with up to 2^{21} word addresses, as displayed in Figure 14-1. Reading the memory space between address pw and $2^{21}-1$ returns an undefined result. The User page is permanently mapped to word address 2^{21} .

Table 14-1. User page addresses

| Memory type | Start address, byte sized | Size |
|-------------|---------------------------|--------------------------|
| Main array | 0 | pw words = $4pw$ bytes |
| User | $2^{23} = 8388608$ | w words = $4w$ bytes |

Figure 14-1. Memory map for the Flash memories

All addresses are word addresses

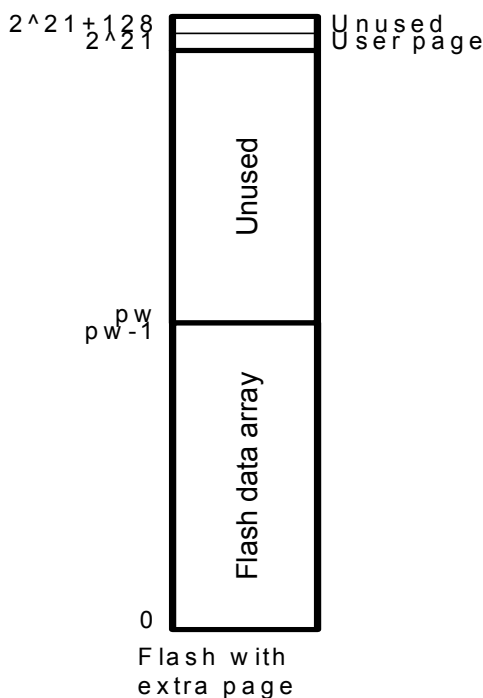

14.4.5 Quick Page Read

A dedicated command, Quick Page Read (QPR), is provided to read all words in an addressed page. All bits in all words in this page are AND'ed together, returning a 1-bit result. This result is placed in the Quick Page Read Result (QPRR) bit in Flash Status Register (FSR). The QPR command is useful to check that a page is in an erased state. The QPR instruction is much faster than performing the erased-page check using a regular software subroutine.

14.4.6 Write page buffer operations

The internal memory area reserved for the embedded flash can also be written through a write-only page buffer. The page buffer is addressed only by the address bits required to address w words (since the page buffer is word addressable) and thus wrap around within the internal memory area address space and appear to be repeated within it.

When writing to the page buffer, the PAGEN field in the Flash Command register (FCMD) is updated with the page number corresponding to page address of the latest word written into the page buffer.

The page buffer is also used for writes to the User page.

Write operations can be prevented by programming the Memory Protection Unit of the CPU. Writing 8-bit and 16-bit data to the page buffer is not allowed and may lead to unpredictable data corruption.

Page buffer write operations are performed with 4 wait states.

Writing to the page buffer can only change page buffer bits from one to zero, i.e. writing 0xaaaaaaaa to a page buffer location that has the value 0x00000000, will not change the page buffer value. The only way to change a bit from zero to one, is to reset the entire page buffer with the Clear Page Buffer command.

The page buffer is not automatically reset after a page write. The programmer should do this manually by issuing the Clear Page Buffer flash command. This can be done after a page write, or before the page buffer is loaded with data to be stored to the flash page.

Example: Writing a word into word address 130 of a flash with 128 words in the page buffer. PAGEN will be updated with the value 1, and the word will be written into word 2 in the page buffer.

14.4.7 Writing words to a page that is not completely erased

This can be used for EEPROM emulation, i.e. writes with granularity of one word instead of an entire page. Only words that are in a completely erased state (0xFFFFFFFF) can be changed. The procedure is as follows:

1. Clear page buffer
2. Write to the page buffer the result of the logical bitwise AND operation between the contents of the flash page and the new data to write. Only words that were in an erased state can be changed from the original page.
3. Write Page.

14.5 Flash commands

The FLASHC offers a command set to manage programming of the flash memory, locking and unlocking of regions, and full flash erasing. See chapter 14.8.2 for a complete list of commands.

To run a command, the field FCMD.CMD has to be written with the command number. As soon as FCMD is written, the FRDY bit is automatically cleared. Once the current command is complete, the FRDY bit is automatically set. If an interrupt has been enabled by setting the bit FRDY in FCR, the interrupt line of the flash controller is activated. All flash commands except for Quick Page Read (QPR) will generate an interrupt request upon completion if FRDY is set.

After a command has been written to FCMD, the programming algorithm should wait until the command has been executed before attempting to read instructions or data from the flash or writing to the page buffer, as the flash will be busy. The waiting can be performed either by polling the Flash Status Register (FSR) or by waiting for the flash ready interrupt. The command written to FCMD is initiated on the first clock cycle where the HSB bus interface in FLASHC is IDLE. The user must make sure that the access pattern to the FLASHC HSB interface contains an IDLE cycle so that the command is allowed to start. Make sure that no bus masters such as DMA controllers are performing endless burst transfers from the flash. Also, make sure that the CPU does not perform endless burst transfers from flash. This is done by letting the CPU enter sleep mode after writing to FCMD, or by polling FSR for command completion. This polling will result in an access pattern with IDLE HSB cycles.

All the commands are protected by the same keyword, which has to be written in the eight highest bits of FCMD. Writing FCMD with data that does not contain the correct key and/or with an invalid command has no effect on the flash memory; however, the PROGE bit is set in FSR. This bit is automatically cleared by a read access to FSR.

Writing a command to FCMD while another command is being executed has no effect on the flash memory; however, the PROGE bit is set in FSR. This bit is automatically cleared by a read access to FSR.

If the current command writes or erases a page in a locked region, or a page protected by the BOOTPROT fuses, the command has no effect on the flash memory; however, the LOCKE bit is set in FSR. This bit is automatically cleared by a read access to FSR.

14.5.1 Write/erase page operation

Flash technology requires that an erase must be done before programming. The entire flash can be erased by an Erase All command. Alternatively, pages can be individually erased by the Erase Page command.

The User page can be written and erased using the mechanisms described in this chapter.

After programming, the page can be locked to prevent miscellaneous write or erase sequences. Locking is performed on a per-region basis, so locking a region locks all pages inside the region. Additional protection is provided for the lowermost address space of the flash. This address space is allocated for the Boot Loader, and is protected both by the lock bit(s) corresponding to this address space, and the BOOTPROT[2:0] fuses.

Data to be written are stored in an internal buffer called page buffer. The page buffer contains *w* words. The page buffer wraps around within the internal memory area address space and appears to be repeated by the number of pages in it. Writing of 8-bit and 16-bit data to the page buffer is not allowed and may lead to unpredictable data corruption.

Data must be written to the page buffer before the programming command is written to FCMD. The sequence is as follows:

- Reset the page buffer with the Clear Page Buffer command.
- Fill the page buffer with the desired contents, using only 32-bit access.
- Programming starts as soon as the programming key and the programming command are written to the Flash Command Register. The FCMD.PAGEN field must contain the address of the page to write. PAGEN is automatically updated when writing to the page buffer, but can also be written to directly. The FRDY bit in FSR is automatically cleared when the page write operation starts.
- When programming is completed, the bit FRDY in FSR is set. If an interrupt was enabled by setting the bit FRDY in FCR, the interrupt line of the flash controller is set.

Two errors can be detected in FSR after a programming sequence:

- Programming Error: A bad keyword and/or an invalid command have been written in FCMD.
- Lock Error: The page to be programmed belongs to a locked region. A command must be executed to unlock the corresponding region before programming can start.

14.5.2 Erase All operation

The entire memory is erased if the Erase All command (EA) is written to FCMD. Erase All erases all bits in the flash array. The User page is not erased. All flash memory locations, the general-purpose fuse bits, and the security bit are erased (reset to 0xFF) after an Erase All.

The EA command also ensures that all volatile memories, such as register file and RAMs, are erased before the security bit is erased.

Erase All operation is allowed only if no regions are locked, and the BOOTPROT fuses are programmed with a region size of 0. Thus, if at least one region is locked, the bit LOCKE in FSR is set and the command is cancelled. If the bit LOCKE has been written to 1 in FCR, the interrupt line rises.

When the command is complete, the bit FRDY bit in FSR is set. If an interrupt has been enabled by setting the bit FRDY in FCR, the interrupt line of the flash controller is set. Two errors can be detected in FSR after issuing the command:

- Programming Error: A bad keyword and/or an invalid command have been written in FCMD.
- Lock Error: At least one lock region to be erased is protected, or BOOTPROT is different from 0. The erase command has been refused and no page has been erased. A Clear Lock Bit command must be executed previously to unlock the corresponding lock regions.

14.5.3 Region lock bits

The flash block has p pages, and these pages are grouped into 16 lock regions, each region containing $p/16$ pages. Each region has a dedicated lock bit preventing writing and erasing pages in the region. After production, the device may have some regions locked. These locked regions are reserved for a boot or default application. Locked regions can be unlocked to be erased and then programmed with another application or other data.

To lock or unlock a region, the commands Lock Region Containing Page (LP) and Unlock Region Containing Page (UP) are provided. Writing one of these commands, together with the number of the page whose region should be locked/unlocked, performs the desired operation.

One error can be detected in FSR after issuing the command:

- Programming Error: A bad keyword and/or an invalid command have been written in FCMD.

The lock bits are implemented using the lowest 16 general-purpose fuse bits. This means that lock bits can also be set/cleared using the commands for writing/erasing general-purpose fuse bits, see chapter 14.6. The general-purpose bit being in an erased (1) state means that the region is unlocked.

The lowermost pages in the Flash can additionally be protected by the BOOTPROT fuses, see [Section 14.6](#).

14.6 General-purpose fuse bits

Each flash block has a number of general-purpose fuse bits that the application programmer can use freely. The fuse bits can be written and erased using dedicated commands, and read

through a dedicated Peripheral Bus address. Some of the general-purpose fuse bits are reserved for special purposes, and should not be used for other functions.:

Table 14-2. General-purpose fuses with special functions

| General-Purpose fuse number | Name | Usage |
|-----------------------------|----------|--|
| 15:0 | LOCK | Region lock bits. |
| 16 | EPFL | <p>External Privileged Fetch Lock. Used to prevent the CPU from fetching instructions from external memories when in privileged mode. This bit can only be changed when the security bit is cleared. The address range corresponding to external memories is device-specific, and not known to the flash controller. This fuse bit is simply routed out of the CPU or bus system, the flash controller does not treat this fuse in any special way, except that it can not be altered when the security bit is set.</p> <p>If the security bit is set, only an external JTAG Chip Erase can clear EPFL. No internal commands can alter EPFL if the security bit is set.</p> <p>When the fuse is erased (i.e. "1"), the CPU can execute instructions fetched from external memories. When the fuse is programmed (i.e. "0"), instructions can not be executed from external memories.</p> |
| 19:17 | BOOTPROT | <p>Used to select one of eight different boot loader sizes. Pages included in the bootlegger area can not be erased or programmed except by a JTAG chip erase. BOOTPROT can only be changed when the security bit is cleared.</p> <p>If the security bit is set, only an external JTAG Chip Erase can clear BOOTPROT, and thereby allow the pages protected by BOOTPROT to be programmed. No internal commands can alter BOOTPROT or the pages protected by BOOTPROT if the security bit is set.</p> |

The BOOTPROT fuses protects the following address space for the Boot Loader:

Table 14-3. Boot Loader area specified by BOOTPROT

| BOOTPROT | Pages protected by BOOTPROT | Size of protected memory |
|----------|-----------------------------|--------------------------|
| 7 | None | 0 |
| 6 | 0-1 | 1kByte |
| 5 | 0-3 | 2kByte |
| 4 | 0-7 | 4kByte |
| 3 | 0-15 | 8kByte |
| 2 | 0-31 | 16kByte |
| 1 | 0-63 | 32kByte |
| 0 | 0-127 | 64kByte |

To erase or write a general-purpose fuse bit, the commands Write General-Purpose Fuse Bit (WGPB) and Erase General-Purpose Fuse Bit (EGPB) are provided. Writing one of these commands, together with the number of the fuse to write/erase, performs the desired operation.

An entire General-Purpose Fuse byte can be written at a time by using the Program GP Fuse Byte (PGPFB) instruction. A PGPFB to GP fuse byte 2 is not allowed if the flash is locked by the security bit. The PFB command is issued with a parameter in the PAGEN field:

- PAGEN[2:0] - byte to write
- PAGEN[10:3] - Fuse value to write

All General-Purpose fuses can be erased by the Erase All General-Purpose fuses (EAGP) command. An EAGP command is not allowed if the flash is locked by the security bit.

Two errors can be detected in FSR after issuing these commands:

- Programming Error: A bad keyword and/or an invalid command have been written in FCMD.
- Lock Error: A write or erase of any of the special-function fuse bits in [Table 14-3](#) was attempted while the flash is locked by the security bit.

The lock bits are implemented using the lowest 16 general-purpose fuse bits. This means that the 16 lowest general-purpose fuse bits can also be written/erased using the commands for locking/unlocking regions, see [Section 14.5.3](#).

14.7 Security bit

The security bit allows the entire chip to be locked from external JTAG or other debug access for code security. The security bit can be written by a dedicated command, Set Security Bit (SSB). Once set, the only way to clear the security bit is through the JTAG Chip Erase command.

Once the Security bit is set, the following Flash controller commands will be unavailable and return a lock error if attempted:

- Write General-Purpose Fuse Bit (WGPB) to BOOTPROT or EPFL fuses
- Erase General-Purpose Fuse Bit (EGPB) to BOOTPROT or EPFL fuses
- Program General-Purpose Fuse Byte (PGPFB) of fuse byte 2
- Erase All General-Purpose Fuses (EAGPF)

One error can be detected in FSR after issuing the command:

- Programming Error: A bad keyword and/or an invalid command have been written in FCMD.

14.8 User Interface

Table 14-4. FLASHC Register Memory Map

| Offset | Register | Name | Access | Reset |
|--------|--|---------|--------|----------------|
| 0x0 | Flash Control Register | FCR | R/W | 0x00000000 |
| 0x4 | Flash Command Register | FCMD | R/W | 0x00000000 |
| 0x8 | Flash Status Register | FSR | R/W | 0x00000000 (*) |
| 0xc | Flash General Purpose Fuse Register Hi | FGPFRHI | R | NA (*) |
| 0x10 | Flash General Purpose Fuse Register Lo | FGPFRLO | R | NA (*) |

(*) The value of the Lock bits is dependent of their programmed state. All other bits in FSR are 0. All bits in FGPFR and FCFR are dependent on the programmed state of the fuses they map to. Any bits in these registers not mapped to a fuse read 0.

14.8.1 Flash Control Register

Name: FCR
Access Type: Read/Write
Offset: 0x00
Reset value: 0x00000000

| | | | | | | | |
|----|-----|----|----|-------|-------|----|------|
| 31 | 30 | 29 | 28 | 27 | 26 | 25 | 24 |
| - | - | - | - | - | - | - | - |
| 23 | 22 | 21 | 20 | 19 | 18 | 17 | 16 |
| - | - | - | - | - | - | - | - |
| 15 | 14 | 13 | 12 | 11 | 10 | 9 | 8 |
| - | - | - | - | - | - | - | - |
| 7 | 6 | 5 | 4 | 3 | 2 | 1 | 0 |
| - | FWS | - | - | PROGE | LOCKE | - | FRDY |

- **FRDY: Flash Ready Interrupt Enable**
 0: Flash Ready does not generate an interrupt.
 1: Flash Ready generates an interrupt.
- **LOCKE: Lock Error Interrupt Enable**
 0: Lock Error does not generate an interrupt.
 1: Lock Error generates an interrupt.
- **PROGE: Programming Error Interrupt Enable**
 0: Programming Error does not generate an interrupt.
 1: Programming Error generates an interrupt.
- **FWS: Flash Wait State**
 0: The flash is read with 0 wait states.
 1: The flash is read with 1 wait state.



14.8.2 Flash Command Register

Name: FCMD
Access Type: Read/Write
Offset: 0x04
Reset value: 0x00000000

FCMD can not be written if the flash is in the process of performing a flash command. Doing so will cause the FCR write to be ignored, and the PROGE bit to be set.

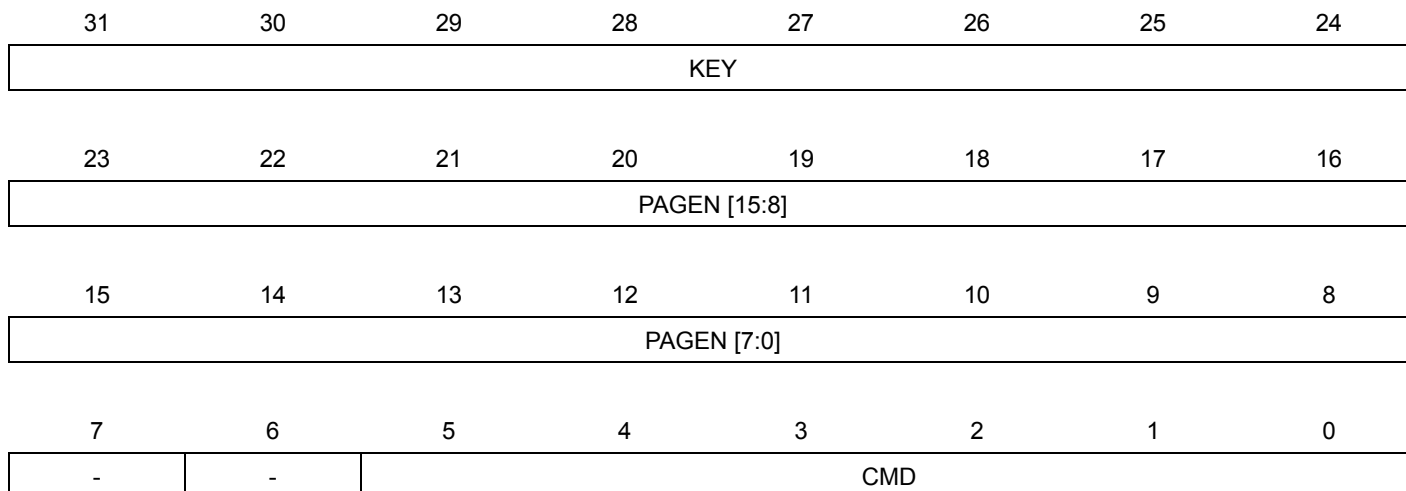

- **CMD: Command**

This field defines the flash command. Issuing any unused command will cause the Programming Error bit to be set, and the corresponding interrupt to be requested if FCR.PROGE is set.

Table 14-5. Set of commands

| Command | Value | Mnemonic |
|-------------------------------------|-------|----------|
| No operation | 0 | NOP |
| Write Page | 1 | WP |
| Erase Page | 2 | EP |
| Clear Page Buffer | 3 | CPB |
| Lock region containing given Page | 4 | LP |
| Unlock region containing given Page | 5 | UP |
| Erase All | 6 | EA |
| Write General-Purpose Fuse Bit | 7 | WGPB |
| Erase General-Purpose Fuse Bit | 8 | EGPB |
| Set Security Bit | 9 | SSB |
| Program GP Fuse Byte | 10 | PGPFB |
| Erase All GPFuses | 11 | EAGPF |
| Quick Page Read | 12 | QPR |

Table 14-5. Set of commands

| Command | Value | Mnemonic |
|---------------------------|-------|----------|
| Write User Page | 13 | WUP |
| Erase User Page | 14 | EUP |
| Quick Page Read User Page | 15 | QPRUP |

- **PAGEN: Page number**

The PAGEN field is used to address a page or fuse bit for certain operations. In order to simplify programming, the PAGEN field is automatically updated every time the page buffer is written to. For every page buffer write, the PAGEN field is updated with the page number of the address being written to. Hardware automatically masks writes to the PAGEN field so that only bits representing valid page numbers can be written, all other bits in PAGEN are always 0. As an example, in a flash with 1024 pages (page 0 - page 1023), bits 15:10 will always be 0.

Table 14-6. Semantic of PAGEN field in different commands

| Command | PAGEN description |
|-------------------------------------|---|
| No operation | Not used |
| Write Page | The number of the page to write |
| Clear Page Buffer | Not used |
| Lock region containing given Page | Page number whose region should be locked |
| Unlock region containing given Page | Page number whose region should be unlocked |
| Erase All | Not used |
| Write General-Purpose Fuse Bit | GPFUSE # |
| Erase General-Purpose Fuse Bit | GPFUSE # |
| Set Security Bit | Not used |
| Program GP Fuse Byte | WriteData[7:0], ByteAddress[2:0] |
| Erase All GP Fuses | Not used |
| Quick Page Read | Page number |
| Write User Page | Not used |
| Erase User Page | Not used |
| Quick Page Read User Page | Not used |

- **KEY: Write protection key**

This field should be written with the value 0xA5 to enable the command defined by the bits of the register. If the field is written with a different value, the write is not performed and no action is started.

This field always reads as 0.

14.8.3 Flash Status Register

Name: FSR
Access Type: Read/Write
Offset: 0x08
Reset value: 0x00000000

| | | | | | | | |
|--------|--------|--------|----------|--------|--------|-------|-------|
| 31 | 30 | 29 | 28 | 27 | 26 | 25 | 24 |
| LOCK15 | LOCK14 | LOCK13 | LOCK12 | LOCK11 | LOCK10 | LOCK9 | LOCK8 |
| 23 | 22 | 21 | 20 | 19 | 18 | 17 | 16 |
| LOCK7 | LOCK6 | LOCK5 | LOCK4 | LOCK3 | LOCK2 | LOCK1 | LOCK0 |
| 15 | 14 | 13 | 12 | 11 | 10 | 9 | 8 |
| FSZ | | - | - | - | - | - | - |
| 7 | 6 | 5 | 4 | 3 | 2 | 1 | 0 |
| - | - | QPRR | SECURITY | PROGE | LOCKE | - | FRDY |

- FRDY: Flash Ready Status**
 0: The flash controller is busy and the application must wait before running a new command.
 1: The flash controller is ready to run a new command.
- LOCKE: Lock Error Status**
 Automatically cleared when FSR is read.
 0: No programming of at least one locked lock region has happened since the last read of FSR.
 1: Programming of at least one locked lock region has happened since the last read of FSR.
- PROGE: Programming Error Status**
 Automatically cleared when FSR is read.
 0: No invalid commands and no bad keywords were written in FCMD.
 1: An invalid command and/or a bad keyword was/were written in FCMD.
- SECURITY: Security Bit Status**
 0: The security bit is inactive.
 1: The security bit is active.
- QPRR: Quick Page Read Result**
 0: The result is zero, i.e. the page is not erased.
 1: The result is one, i.e. the page is erased.

- **FSZ: Flash Size**

The size of the flash. Not all device families will provide all flash sizes indicated in the table.

Table 14-7. Flash size

| FSZ | Flash Size |
|-----|-------------|
| 0 | 32 Kbytes |
| 1 | 64 Kbytes |
| 2 | 128 Kbytes |
| 3 | 256 Kbytes |
| 4 | 384 Kbytes |
| 5 | 512 Kbytes |
| 6 | 768 Kbytes |
| 7 | 1024 Kbytes |

- **LOCKx: Lock Region x Lock Status**

0: The corresponding lock region is not locked.

1: The corresponding lock region is locked.

14.8.4 Flash General Purpose Fuse Register High

Name: FGPF RH
Access Type: Read
Offset: 0x0C
Reset value: N/A

| | | | | | | | |
|-------|-------|-------|-------|-------|-------|-------|-------|
| 31 | 30 | 29 | 28 | 27 | 26 | 25 | 24 |
| GPF63 | GPF62 | GPF61 | GPF60 | GPF59 | GPF58 | GPF57 | GPF56 |
| 23 | 22 | 21 | 20 | 19 | 18 | 17 | 16 |
| GPF55 | GPF54 | GPF53 | GPF52 | GPF51 | GPF50 | GPF49 | GPF48 |
| 15 | 14 | 13 | 12 | 11 | 10 | 9 | 8 |
| GPF47 | GPF46 | GPF45 | GPF44 | GPF43 | GPF42 | GPF41 | GPF40 |
| 7 | 6 | 5 | 4 | 3 | 2 | 1 | 0 |
| GPF39 | GPF38 | GPF37 | GPF36 | GPF35 | GPF34 | GPF33 | GPF32 |

This register is only used in systems with more than 32 GP fuses.

- GPFxx: General Purpose Fuse xx**
 0: The fuse has a written/programmed state.
 1: The fuse has an erased state.

14.8.5 Flash General Purpose Fuse Register Low

Name: FGPFRL0
Access Type: Read
Offset: 0x10
Reset value: N/A

| | | | | | | | |
|-------|-------|-------|-------|-------|-------|-------|-------|
| 31 | 30 | 29 | 28 | 27 | 26 | 25 | 24 |
| GPF31 | GPF30 | GPF29 | GPF28 | GPF27 | GPF26 | GPF25 | GPF24 |
| 23 | 22 | 21 | 20 | 19 | 18 | 17 | 16 |
| GPF23 | GPF22 | GPF21 | GPF20 | GPF19 | GPF18 | GPF17 | GPF16 |
| 15 | 14 | 13 | 12 | 11 | 10 | 9 | 8 |
| GPF15 | GPF14 | GPF13 | GPF12 | GPF11 | GPF10 | GPF09 | GPF08 |
| 7 | 6 | 5 | 4 | 3 | 2 | 1 | 0 |
| GPF07 | GPF06 | GPF05 | GPF04 | GPF03 | GPF02 | GPF01 | GPF00 |

- GPFxx: General Purpose Fuse xx**
 0: The fuse has a written/programmed state.
 1: The fuse has an erased state.

14.9 Fuses Settings

The flash block contains a number of general purpose fuses. Some of these fuses have defined meanings outside the flash controller and are described in this section.

The general purpose fuses are erase by a JTAG chip erase.

14.9.1 Flash General Purpose Fuse Register Low (FGPFRLO)

| | | | | | | | |
|---------------|-------|-------|-------|----------|---------|---------------|------|
| 31 | 30 | 29 | 28 | 27 | 26 | 25 | 24 |
| GPF31 | GPF30 | GPF29 | BODEN | | BODHYST | BODLEVEL[5:4] | |
| 23 | 22 | 21 | 20 | 19 | 18 | 17 | 16 |
| BODLEVEL[3:0] | | | | BOOTPROT | | | EPFL |
| 15 | 14 | 13 | 12 | 11 | 10 | 9 | 8 |
| LOCK[15:8] | | | | | | | |
| 7 | 6 | 5 | 4 | 3 | 2 | 1 | 0 |
| LOCK[7:0] | | | | | | | |

BODEN: Brown Out Detector Enable

| BODEN | Description |
|-------|---------------------------------|
| 0x0 | BOD disabled |
| 0x1 | BOD enabled, BOD reset enabled |
| 0x2 | BOD enabled, BOD reset disabled |
| 0x3 | BOD disabled |

BODHYST: Brown Out Detector Hysteresis

0: The Brown out detector hysteresis is disabled

1: The Brown out detector hysteresis is enabled

BODLEVEL: Brown Out Detector Trigger Level

This controls the voltage trigger level for the Brown out detector. Refer to Electrical Characteristics section. If the BODLEVEL is set higher than VDDCORE and enabled by fuses, the part will be in constant reset. To recover from this situation, apply an external voltage on VDDCORE that is higher than the BOD level and disable the BOD.

LOCK, EPFL, BOOTPROT

These are Flash controller fuses and are described in the FLASHC section.

As no external memories can be connected to AT32UC3B the EPFL bit has no effect.

14.9.2 Default Fuse Value

The devices are shipped with the FGPFRL0 register value: 0xFC07FFFF:

- GPF31 fuse set to 1b. This fuse is used by the pre-programmed USB bootloader.
- GPF30 fuse set to 1b. This fuse is used by the pre-programmed USB bootloader.
- GPF29 fuse set to 1b. This fuse is used by the pre-programmed USB bootloader.
- BODEN fuses set to 11b. BOD is disabled.
- BODHYST fuse set to 1b. The BOD hysteresis is enabled.
- BODLEVEL fuses set to 000000b. This is the minimum voltage trigger level. BOD will never trigger as this level is below the POR level.
- BOOTPROT fuses set to 011b. The bootloader protected size is 8 Ko.
- EPFL fuse set to 1b. External privileged fetch is not locked.
- LOCK fuses set to 1111111111111111b. No region locked.

See also the AT32UC3B Bootloader user guide document.

After the JTAG chip erase command, the FGPFRL0 register value is 0xFFFFFFFF.

14.10 Bootloader Configuration

The bootloader uses one word in the flash User page to store its configuration. This configuration word is located at address 0x808001FC and its default value is 0x929E0D6B.

Refer to the bootloader documentation for more information.

14.11 Serial Number

Each device has a unique 120 bits serial number readable from address 0x80800204 to 0x80800212.

14.12 Module configuration

Table 14-8. Flash Memory Parameters

| Part Number | Flash Size (FLASH_PW) | Number of pages (FLASH_P) | Page size (FLASH_W) | General Purpose Fuse bits (FLASH_L) |
|--------------|--------------------------|------------------------------|------------------------|---|
| AT32UC3B0512 | 512 Kbytes | 1024 | 128 words | 32 fuses |
| AT32UC3B1512 | 512 Kbytes | 1024 | 128 words | 32 fuses |
| AT32UC3B0256 | 256 Kbytes | 512 | 128 words | 32 fuses |
| AT32UC3B1256 | 256 Kbytes | 512 | 128 words | 32 fuses |
| AT32UC3B0128 | 128 Kbytes | 256 | 128 words | 32 fuses |
| AT32UC3B1128 | 128 Kbytes | 256 | 128 words | 32 fuses |
| AT32UC3B064 | 64 Kbytes | 128 | 128 words | 32 fuses |
| AT32UC3B164 | 64 Kbytes | 128 | 128 words | 32 fuses |

15. HSB Bus Matrix (HMATRIX)

Rev: 2.3.0.2

15.1 Features

- User Interface on peripheral bus
- Configurable Number of Masters (Up to sixteen)
- Configurable Number of Slaves (Up to sixteen)
- One Decoder for Each Master
-
- Programmable Arbitration for Each Slave
 - Round-Robin
 - Fixed Priority
- Programmable Default Master for Each Slave
 - No Default Master
 - Last Accessed Default Master
 - Fixed Default Master
- One Cycle Latency for the First Access of a Burst
- Zero Cycle Latency for Default Master
- One Special Function Register for Each Slave (Not dedicated)

15.2 Overview

The Bus Matrix implements a multi-layer bus structure, that enables parallel access paths between multiple High Speed Bus (HSB) masters and slaves in a system, thus increasing the overall bandwidth. The Bus Matrix interconnects up to 16 HSB Masters to up to 16 HSB Slaves. The normal latency to connect a master to a slave is one cycle except for the default master of the accessed slave which is connected directly (zero cycle latency). The Bus Matrix provides 16 Special Function Registers (SFR) that allow the Bus Matrix to support application specific features.

15.3 Product Dependencies

In order to use this module, other parts of the system must be configured correctly, as described below.

15.3.1 Clocks

The clock for the HMATRIX bus interface (CLK_HMATRIX) is generated by the Power Manager. This clock is enabled at reset, and can be disabled in the Power Manager. It is recommended to disable the HMATRIX before disabling the clock, to avoid freezing the HMATRIX in an undefined state.

15.4 Functional Description

15.4.1 Special Bus Granting Mechanism

The Bus Matrix provides some speculative bus granting techniques in order to anticipate access requests from some masters. This mechanism reduces latency at first access of a burst or single transfer. This bus granting mechanism sets a different default master for every slave.

At the end of the current access, if no other request is pending, the slave remains connected to its associated default master. A slave can be associated with three kinds of default masters: no default master, last access master and fixed default master.

15.4.1.1 *No Default Master*

At the end of the current access, if no other request is pending, the slave is disconnected from all masters. No Default Master suits low-power mode.

15.4.1.2 *Last Access Master*

At the end of the current access, if no other request is pending, the slave remains connected to the last master that performed an access request.

15.4.1.3 *Fixed Default Master*

At the end of the current access, if no other request is pending, the slave connects to its fixed default master. Unlike last access master, the fixed master does not change unless the user modifies it by a software action (field `FIXED_DEFMSTR` of the related SCFG).

To change from one kind of default master to another, the Bus Matrix user interface provides the Slave Configuration Registers, one for each slave, that set a default master for each slave. The Slave Configuration Register contains two fields: `DEFMSTR_TYPE` and `FIXED_DEFMSTR`. The 2-bit `DEFMSTR_TYPE` field selects the default master type (no default, last access master, fixed default master), whereas the 4-bit `FIXED_DEFMSTR` field selects a fixed default master provided that `DEFMSTR_TYPE` is set to fixed default master. Please refer to the Bus Matrix user interface description.

15.4.2 **Arbitration**

The Bus Matrix provides an arbitration mechanism that reduces latency when conflict cases occur, i.e. when two or more masters try to access the same slave at the same time. One arbiter per HSB slave is provided, thus arbitrating each slave differently.

The Bus Matrix provides the user with the possibility of choosing between 2 arbitration types for each slave:

1. Round-Robin Arbitration (default)
2. Fixed Priority Arbitration

This choice is made via the field `ARBT` of the Slave Configuration Registers (SCFG).

Each algorithm may be complemented by selecting a default master configuration for each slave.

When a re-arbitration must be done, specific conditions apply. See [Section 15.4.2.1 "Arbitration Rules" on page 139](#).

15.4.2.1 *Arbitration Rules*

Each arbiter has the ability to arbitrate between two or more different master requests. In order to avoid burst breaking and also to provide the maximum throughput for slave interfaces, arbitration may only take place during the following cycles:

1. Idle Cycles: When a slave is not connected to any master or is connected to a master which is not currently accessing it.
2. Single Cycles: When a slave is currently doing a single access.

3. End of Burst Cycles: When the current cycle is the last cycle of a burst transfer. For defined length burst, predicted end of burst matches the size of the transfer but is managed differently for undefined length burst.
4. Slot Cycle Limit: When the slot cycle counter has reached the limit value indicating that the current master access is too long and must be broken.

- Undefined Length Burst Arbitration

In order to avoid long slave handling during undefined length bursts (INCR), the Bus Matrix provides specific logic in order to re-arbitrate before the end of the INCR transfer. A predicted end of burst is used as a defined length burst transfer and can be selected from among the following five possibilities:

1. Infinite: No predicted end of burst is generated and therefore INCR burst transfer will never be broken.
2. One beat bursts: Predicted end of burst is generated at each single transfer inside the INCP transfer.
3. Four beat bursts: Predicted end of burst is generated at the end of each four beat boundary inside INCR transfer.
4. Eight beat bursts: Predicted end of burst is generated at the end of each eight beat boundary inside INCR transfer.
5. Sixteen beat bursts: Predicted end of burst is generated at the end of each sixteen beat boundary inside INCR transfer.

This selection can be done through the field ULBT of the Master Configuration Registers (MCFG).

- Slot Cycle Limit Arbitration

The Bus Matrix contains specific logic to break long accesses, such as very long bursts on a very slow slave (e.g., an external low speed memory). At the beginning of the burst access, a counter is loaded with the value previously written in the SLOT_CYCLE field of the related Slave Configuration Register (SCFG) and decreased at each clock cycle. When the counter reaches zero, the arbiter has the ability to re-arbitrate at the end of the current byte, half word or word transfer.

15.4.2.2 Round-Robin Arbitration

This algorithm allows the Bus Matrix arbiters to dispatch the requests from different masters to the same slave in a round-robin manner. If two or more master requests arise at the same time, the master with the lowest number is first serviced, then the others are serviced in a round-robin manner.

There are three round-robin algorithms implemented:

1. Round-Robin arbitration without default master
2. Round-Robin arbitration with last default master
3. Round-Robin arbitration with fixed default master

- Round-Robin Arbitration without Default Master

This is the main algorithm used by Bus Matrix arbiters. It allows the Bus Matrix to dispatch requests from different masters to the same slave in a pure round-robin manner. At the end of

the current access, if no other request is pending, the slave is disconnected from all masters. This configuration incurs one latency cycle for the first access of a burst. Arbitration without default master can be used for masters that perform significant bursts.

- Round-Robin Arbitration with Last Default Master

This is a biased round-robin algorithm used by Bus Matrix arbiters. It allows the Bus Matrix to remove the one latency cycle for the last master that accessed the slave. In fact, at the end of the current transfer, if no other master request is pending, the slave remains connected to the last master that performed the access. Other non privileged masters still get one latency cycle if they want to access the same slave. This technique can be used for masters that mainly perform single accesses.

- Round-Robin Arbitration with Fixed Default Master

This is another biased round-robin algorithm. It allows the Bus Matrix arbiters to remove the one latency cycle for the fixed default master per slave. At the end of the current access, the slave remains connected to its fixed default master. Every request attempted by this fixed default master will not cause any latency whereas other non privileged masters will still get one latency cycle. This technique can be used for masters that mainly perform single accesses.

15.4.2.3 Fixed Priority Arbitration

This algorithm allows the Bus Matrix arbiters to dispatch the requests from different masters to the same slave by using the fixed priority defined by the user. If two or more master requests are active at the same time, the master with the highest priority number is serviced first. If two or more master requests with the same priority are active at the same time, the master with the highest number is serviced first.

For each slave, the priority of each master may be defined through the Priority Registers for Slaves (PRAS and PRBS).

15.4.3 Slave and Master assignation

The index number assigned to Bus Matrix slaves and masters are described in Memories chapter.

15.5 User Interface

Table 15-1. HMATRIX Register Memory Map

| Offset | Register | Name | Access | Reset Value |
|--------|----------------------------------|--------|------------|-------------|
| 0x0000 | Master Configuration Register 0 | MCFG0 | Read/Write | 0x00000002 |
| 0x0004 | Master Configuration Register 1 | MCFG1 | Read/Write | 0x00000002 |
| 0x0008 | Master Configuration Register 2 | MCFG2 | Read/Write | 0x00000002 |
| 0x000C | Master Configuration Register 3 | MCFG3 | Read/Write | 0x00000002 |
| 0x0010 | Master Configuration Register 4 | MCFG4 | Read/Write | 0x00000002 |
| 0x0014 | Master Configuration Register 5 | MCFG5 | Read/Write | 0x00000002 |
| 0x0018 | Master Configuration Register 6 | MCFG6 | Read/Write | 0x00000002 |
| 0x001C | Master Configuration Register 7 | MCFG7 | Read/Write | 0x00000002 |
| 0x0020 | Master Configuration Register 8 | MCFG8 | Read/Write | 0x00000002 |
| 0x0024 | Master Configuration Register 9 | MCFG9 | Read/Write | 0x00000002 |
| 0x0028 | Master Configuration Register 10 | MCFG10 | Read/Write | 0x00000002 |
| 0x002C | Master Configuration Register 11 | MCFG11 | Read/Write | 0x00000002 |
| 0x0030 | Master Configuration Register 12 | MCFG12 | Read/Write | 0x00000002 |
| 0x0034 | Master Configuration Register 13 | MCFG13 | Read/Write | 0x00000002 |
| 0x0038 | Master Configuration Register 14 | MCFG14 | Read/Write | 0x00000002 |
| 0x003C | Master Configuration Register 15 | MCFG15 | Read/Write | 0x00000002 |
| 0x0040 | Slave Configuration Register 0 | SCFG0 | Read/Write | 0x00000010 |
| 0x0044 | Slave Configuration Register 1 | SCFG1 | Read/Write | 0x00000010 |
| 0x0048 | Slave Configuration Register 2 | SCFG2 | Read/Write | 0x00000010 |
| 0x004C | Slave Configuration Register 3 | SCFG3 | Read/Write | 0x00000010 |
| 0x0050 | Slave Configuration Register 4 | SCFG4 | Read/Write | 0x00000010 |
| 0x0054 | Slave Configuration Register 5 | SCFG5 | Read/Write | 0x00000010 |
| 0x0058 | Slave Configuration Register 6 | SCFG6 | Read/Write | 0x00000010 |
| 0x005C | Slave Configuration Register 7 | SCFG7 | Read/Write | 0x00000010 |
| 0x0060 | Slave Configuration Register 8 | SCFG8 | Read/Write | 0x00000010 |
| 0x0064 | Slave Configuration Register 9 | SCFG9 | Read/Write | 0x00000010 |
| 0x0068 | Slave Configuration Register 10 | SCFG10 | Read/Write | 0x00000010 |
| 0x006C | Slave Configuration Register 11 | SCFG11 | Read/Write | 0x00000010 |
| 0x0070 | Slave Configuration Register 12 | SCFG12 | Read/Write | 0x00000010 |
| 0x0074 | Slave Configuration Register 13 | SCFG13 | Read/Write | 0x00000010 |
| 0x0078 | Slave Configuration Register 14 | SCFG14 | Read/Write | 0x00000010 |
| 0x007C | Slave Configuration Register 15 | SCFG15 | Read/Write | 0x00000010 |
| 0x0080 | Priority Register A for Slave 0 | PRAS0 | Read/Write | 0x00000000 |
| 0x0084 | Priority Register B for Slave 0 | PRBS0 | Read/Write | 0x00000000 |
| 0x0088 | Priority Register A for Slave 1 | PRAS1 | Read/Write | 0x00000000 |

Table 15-1. HMATRIX Register Memory Map (Continued)

| Offset | Register | Name | Access | Reset Value |
|--------|----------------------------------|--------|------------|-------------|
| 0x008C | Priority Register B for Slave 1 | PRBS1 | Read/Write | 0x00000000 |
| 0x0090 | Priority Register A for Slave 2 | PRAS2 | Read/Write | 0x00000000 |
| 0x0094 | Priority Register B for Slave 2 | PRBS2 | Read/Write | 0x00000000 |
| 0x0098 | Priority Register A for Slave 3 | PRAS3 | Read/Write | 0x00000000 |
| 0x009C | Priority Register B for Slave 3 | PRBS3 | Read/Write | 0x00000000 |
| 0x00A0 | Priority Register A for Slave 4 | PRAS4 | Read/Write | 0x00000000 |
| 0x00A4 | Priority Register B for Slave 4 | PRBS4 | Read/Write | 0x00000000 |
| 0x00A8 | Priority Register A for Slave 5 | PRAS5 | Read/Write | 0x00000000 |
| 0x00AC | Priority Register B for Slave 5 | PRBS5 | Read/Write | 0x00000000 |
| 0x00B0 | Priority Register A for Slave 6 | PRAS6 | Read/Write | 0x00000000 |
| 0x00B4 | Priority Register B for Slave 6 | PRBS6 | Read/Write | 0x00000000 |
| 0x00B8 | Priority Register A for Slave 7 | PRAS7 | Read/Write | 0x00000000 |
| 0x00BC | Priority Register B for Slave 7 | PRBS7 | Read/Write | 0x00000000 |
| 0x00C0 | Priority Register A for Slave 8 | PRAS8 | Read/Write | 0x00000000 |
| 0x00C4 | Priority Register B for Slave 8 | PRBS8 | Read/Write | 0x00000000 |
| 0x00C8 | Priority Register A for Slave 9 | PRAS9 | Read/Write | 0x00000000 |
| 0x00CC | Priority Register B for Slave 9 | PRBS9 | Read/Write | 0x00000000 |
| 0x00D0 | Priority Register A for Slave 10 | PRAS10 | Read/Write | 0x00000000 |
| 0x00D4 | Priority Register B for Slave 10 | PRBS10 | Read/Write | 0x00000000 |
| 0x00D8 | Priority Register A for Slave 11 | PRAS11 | Read/Write | 0x00000000 |
| 0x00DC | Priority Register B for Slave 11 | PRBS11 | Read/Write | 0x00000000 |
| 0x00E0 | Priority Register A for Slave 12 | PRAS12 | Read/Write | 0x00000000 |
| 0x00E4 | Priority Register B for Slave 12 | PRBS12 | Read/Write | 0x00000000 |
| 0x00E8 | Priority Register A for Slave 13 | PRAS13 | Read/Write | 0x00000000 |
| 0x00EC | Priority Register B for Slave 13 | PRBS13 | Read/Write | 0x00000000 |
| 0x00F0 | Priority Register A for Slave 14 | PRAS14 | Read/Write | 0x00000000 |
| 0x00F4 | Priority Register B for Slave 14 | PRBS14 | Read/Write | 0x00000000 |
| 0x00F8 | Priority Register A for Slave 15 | PRAS15 | Read/Write | 0x00000000 |
| 0x00FC | Priority Register B for Slave 15 | PRBS15 | Read/Write | 0x00000000 |
| 0x0110 | Special Function Register 0 | SFR0 | Read/Write | – |
| 0x0114 | Special Function Register 1 | SFR1 | Read/Write | – |
| 0x0118 | Special Function Register 2 | SFR2 | Read/Write | – |
| 0x011C | Special Function Register 3 | SFR3 | Read/Write | – |
| 0x0120 | Special Function Register 4 | SFR4 | Read/Write | – |
| 0x0124 | Special Function Register 5 | SFR5 | Read/Write | – |
| 0x0128 | Special Function Register 6 | SFR6 | Read/Write | – |



Table 15-1. HMATRIX Register Memory Map (Continued)

| Offset | Register | Name | Access | Reset Value |
|--------|------------------------------|-------|------------|-------------|
| 0x012C | Special Function Register 7 | SFR7 | Read/Write | – |
| 0x0130 | Special Function Register 8 | SFR8 | Read/Write | – |
| 0x0134 | Special Function Register 9 | SFR9 | Read/Write | – |
| 0x0138 | Special Function Register 10 | SFR10 | Read/Write | – |
| 0x013C | Special Function Register 11 | SFR11 | Read/Write | – |
| 0x0140 | Special Function Register 12 | SFR12 | Read/Write | – |
| 0x0144 | Special Function Register 13 | SFR13 | Read/Write | – |
| 0x0148 | Special Function Register 14 | SFR14 | Read/Write | – |
| 0x014C | Special Function Register 15 | SFR15 | Read/Write | – |

15.5.1 Master Configuration Registers

Name: MCFG0...MCFG15

Access Type: Read/Write

Offset: 0x00 - 0x3C

Reset Value: 0x00000002

| | | | | | | | |
|----|----|----|----|----|------|----|----|
| 31 | 30 | 29 | 28 | 27 | 26 | 25 | 24 |
| - | - | - | - | - | - | - | - |
| 23 | 22 | 21 | 20 | 19 | 18 | 17 | 16 |
| - | - | - | - | - | - | - | - |
| 15 | 14 | 13 | 12 | 11 | 10 | 9 | 8 |
| - | - | - | - | - | - | - | - |
| 7 | 6 | 5 | 4 | 3 | 2 | 1 | 0 |
| - | - | - | - | - | ULBT | | |

- **ULBT: Undefined Length Burst Type**

0: Infinite Length Burst

No predicted end of burst is generated and therefore INCR bursts coming from this master cannot be broken.

1: Single Access

The undefined length burst is treated as a succession of single accesses, allowing re-arbitration at each beat of the INCR burst.

2: Four Beat Burst

The undefined length burst is split into a four-beat burst, allowing re-arbitration at each four-beat burst end.

3: Eight Beat Burst

The undefined length burst is split into an eight-beat burst, allowing re-arbitration at each eight-beat burst end.

4: Sixteen Beat Burst

The undefined length burst is split into a sixteen-beat burst, allowing re-arbitration at each sixteen-beat burst end.

15.5.2 Slave Configuration Registers

Name: SCFG0...SCFG15

Access Type: Read/Write

Offset: 0x40 - 0x7C

Reset Value: 0x00000010

| | | | | | | | |
|------------|----|---------------|----|----|----|--------------|------|
| 31 | 30 | 29 | 28 | 27 | 26 | 25 | 24 |
| – | – | – | – | – | – | – | ARBT |
| 23 | 22 | 21 | 20 | 19 | 18 | 17 | 16 |
| – | – | FIXED_DEFMSTR | | | | DEFMSTR_TYPE | |
| 15 | 14 | 13 | 12 | 11 | 10 | 9 | 8 |
| – | – | – | – | – | – | – | – |
| 7 | 6 | 5 | 4 | 3 | 2 | 1 | 0 |
| SLOT_CYCLE | | | | | | | |

- **ARBT: Arbitration Type**

0: Round-Robin Arbitration

1: Fixed Priority Arbitration

- **FIXED_DEFMSTR: Fixed Default Master**

This is the number of the Default Master for this slave. Only used if DEFMSTR_TYPE is 2. Specifying the number of a master which is not connected to the selected slave is equivalent to setting DEFMSTR_TYPE to 0.

The size of this field depends on the number of masters. This size is $\log_2(\text{number of masters})$.

- **DEFMSTR_TYPE: Default Master Type**

0: No Default Master

At the end of the current slave access, if no other master request is pending, the slave is disconnected from all masters.

This results in a one cycle latency for the first access of a burst transfer or for a single access.

1: Last Default Master

At the end of the current slave access, if no other master request is pending, the slave stays connected to the last master having accessed it.

This results in not having one cycle latency when the last master tries to access the slave again.

2: Fixed Default Master

At the end of the current slave access, if no other master request is pending, the slave connects to the fixed master the number that has been written in the FIXED_DEFMSTR field.

This results in not having one cycle latency when the fixed master tries to access the slave again.

- **SLOT_CYCLE: Maximum Number of Allowed Cycles for a Burst**

When the SLOT_CYCLE limit is reached for a burst, it may be broken by another master trying to access this slave.

This limit has been placed to avoid locking a very slow slave when very long bursts are used.

This limit must not be very small. Unreasonably small values break every burst and the Bus Matrix arbitrates without performing any data transfer. 16 cycles is a reasonable value for SLOT_CYCLE.

15.5.3 Priority Registers A For Slaves

Name: PRAS0...PRAS15

Access Type: Read/Write

Offset: -

Reset Value: 0x00000000

| | | | | | | | |
|----|----|------|----|----|----|------|----|
| 31 | 30 | 29 | 28 | 27 | 26 | 25 | 24 |
| - | - | M7PR | | - | - | M6PR | |
| 23 | 22 | 21 | 20 | 19 | 18 | 17 | 16 |
| - | - | M5PR | | - | - | M4PR | |
| 15 | 14 | 13 | 12 | 11 | 10 | 9 | 8 |
| - | - | M3PR | | - | - | M2PR | |
| 7 | 6 | 5 | 4 | 3 | 2 | 1 | 0 |
| - | - | M1PR | | - | - | M0PR | |

• **MxPR: Master x Priority**

Fixed priority of Master x for accessing the selected slave. The higher the number, the higher the priority.

15.5.4 Priority Registers B For Slaves

Name: PRBS0...PRBS15

Access Type: Read/Write

Offset: -

Reset Value: 0x00000000

| | | | | | | | |
|----|----|-------|----|----|----|-------|----|
| 31 | 30 | 29 | 28 | 27 | 26 | 25 | 24 |
| - | - | M15PR | | - | - | M14PR | |
| 23 | 22 | 21 | 20 | 19 | 18 | 17 | 16 |
| - | - | M13PR | | - | - | M12PR | |
| 15 | 14 | 13 | 12 | 11 | 10 | 9 | 8 |
| - | - | M11PR | | - | - | M10PR | |
| 7 | 6 | 5 | 4 | 3 | 2 | 1 | 0 |
| - | - | M9PR | | - | - | M8PR | |

- **MxPR: Master x Priority**

Fixed priority of Master x for accessing the selected slave. The higher the number, the higher the priority.

15.5.5 Special Function Registers

Name: SFR0...SFR15

Access Type: Read/Write

Offset: 0x110 - 0x115

Reset Value: -

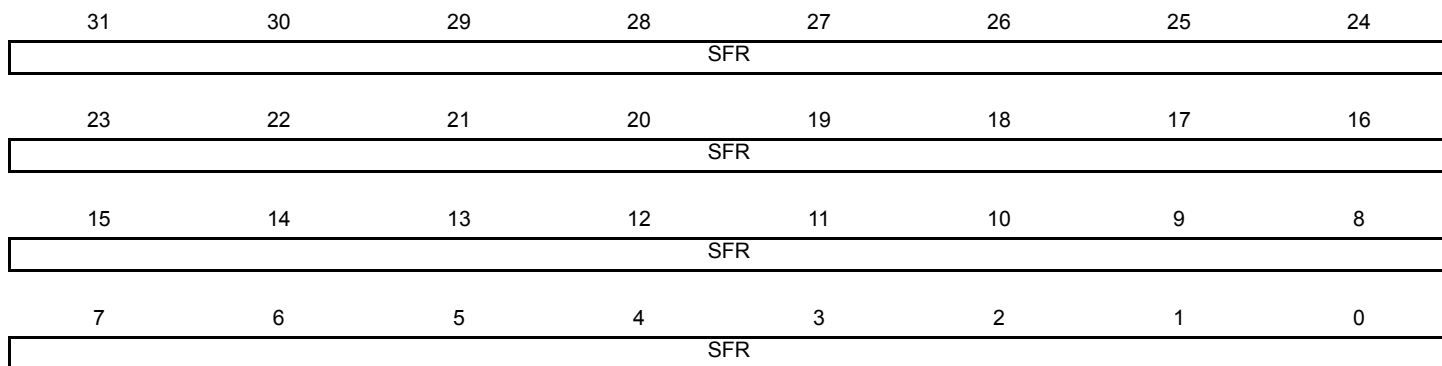

- **SFR: Special Function Register Fields**

Those registers are not a HMATRIX specific register. The field of those will be defined where they are used.

15.6 Bus Matrix Connections

Accesses to unused areas returns an error result to the master requesting such an access.

The bus matrix has the several masters and slaves. Each master has its own bus and its own decoder, thus allowing a different memory mapping per master. The master number in the table below can be used to index the HMATRIX control registers. For example, HMATRIX MCFG0 register is associated with the CPU Data master interface.

Table 15-2. High Speed Bus masters

| | |
|----------|-----------------|
| Master 0 | CPU Data |
| Master 1 | CPU Instruction |
| Master 2 | CPU SAB |
| Master 3 | PDCA |
| Master 4 | USBB DMA |

Each slave has its own arbiter, thus allowing a different arbitration per slave. The slave number in the table below can be used to index the HMATRIX control registers. For example, SCFG3 is associated with the Internal SRAM Slave Interface.

Table 15-3. High Speed Bus slaves

| | |
|---------|-----------------|
| Slave 0 | Internal Flash |
| Slave 1 | HSB-PB Bridge A |
| Slave 2 | HSB-PB Bridge B |
| Slave 3 | Internal SRAM |
| Slave 4 | USBB DPRAM |

Figure 15-1. HMatrix Master / Slave Connections

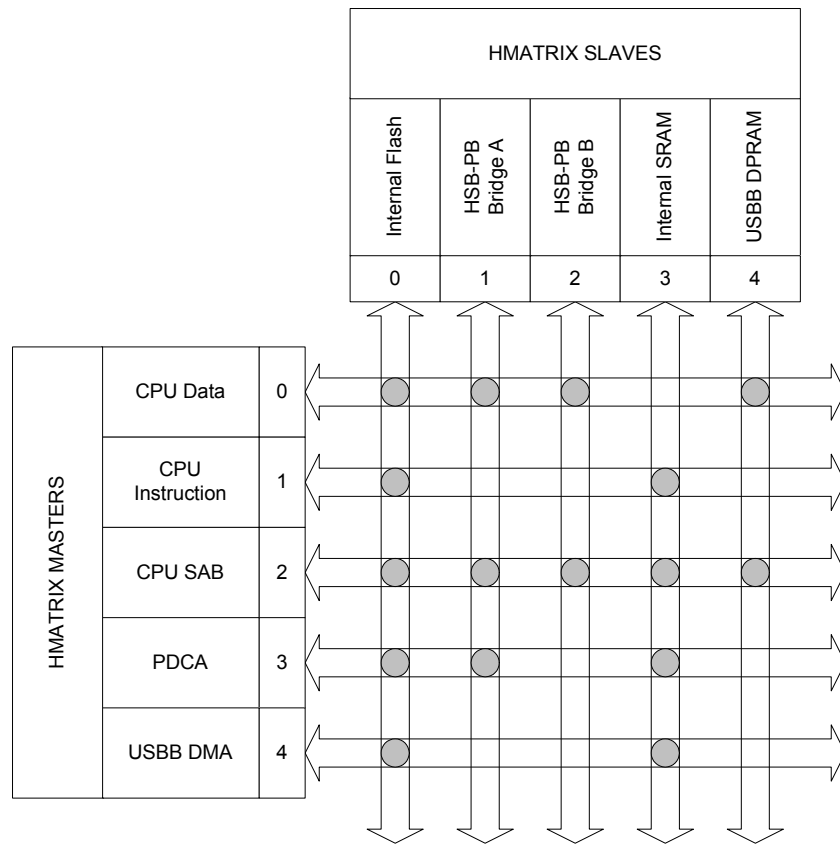

16. Peripheral DMA Controller (PDCA)

Rev: 1.0.2.1

16.1 Features

- **Multiple channels**
- **Generates transfers between memories and peripherals such as USART and SPI**
- **Two address pointers/counters per channel allowing double buffering**

16.2 Overview

The Peripheral DMA Controller (PDCA) transfers data between on-chip peripheral modules such as USART, SPI and memories (those memories may be on- and off-chip memories). Using the PDCA avoids CPU intervention for data transfers, improving the performance of the microcontroller. The PDCA can transfer data from memory to a peripheral or from a peripheral to memory.

The PDCA consists of multiple DMA channels. Each channel has:

- A Peripheral Select Register
- A 32-bit memory pointer
- A 16-bit transfer counter
- A 32-bit memory pointer reload value
- A 16-bit transfer counter reload value

The PDCA communicates with the peripheral modules over a set of handshake interfaces. The peripheral signals the PDCA when it is ready to receive or transmit data. The PDCA acknowledges the request when the transmission has started.

When a transmit buffer is empty or a receive buffer is full, an optional interrupt request can be generated.

16.3 Block Diagram

Figure 16-1. PDCA Block Diagram

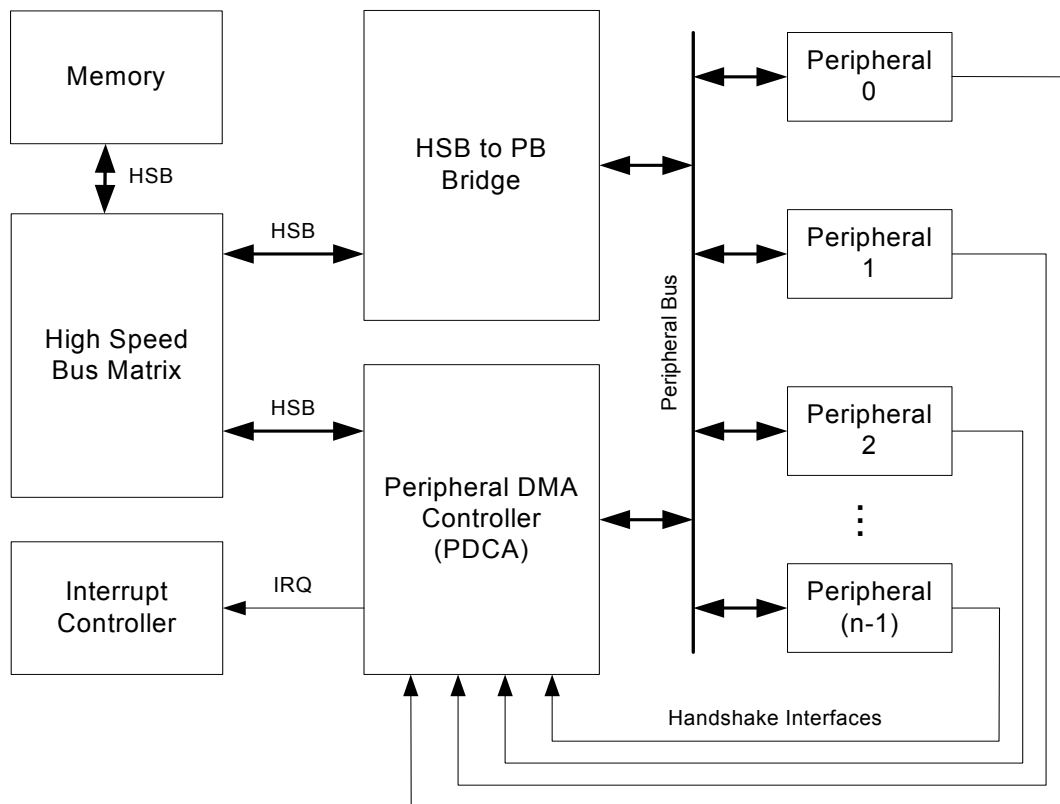

16.4 Product Dependencies

In order to use this module, other parts of the system must be configured correctly, as described below.

16.4.1 Power Management

If the CPU enters a sleep mode that disables the PDCA clocks, the PDCA will stop functioning and resume operation after the system wakes up from sleep mode.

16.4.2 Clocks

The PDCA has two bus clocks connected: One High Speed Bus clock (CLK_PDCA_HSB) and one Peripheral Bus clock (CLK_PDCA_PB). These clocks are generated by the Power Manager. Both clocks are enabled at reset, and can be disabled in the Power Manager. It is recommended to disable the PDCA before disabling the clocks, to avoid freezing the PDCA in an undefined state.

16.4.3 Interrupts

The PDCA interrupt request lines are connected to the interrupt controller. Using the PDCA interrupts requires the interrupt controller to be programmed first.

16.5 Functional Description

16.5.1 Basic Operation

The PDCA consists of multiple independent PDCA channels, each capable of handling DMA requests in parallel. Each PDCA channels contains a set of configuration registers which must be configured to start a DMA transfer.

In this section the steps necessary to configure one PDCA channel is outlined.

The peripheral to transfer data to or from must be configured correctly in the Peripheral Select Register (PSR). This is performed by writing the Peripheral Identity (PID) value for the corresponding peripheral to the PID field in the PSR register. The PID also encodes the transfer direction, i.e. memory to peripheral or peripheral to memory. See [Section 16.5.5](#).

The transfer size must be written to the Transfer Size field in the Mode Register (MR.SIZE). The size must match the data size produced or consumed by the selected peripheral. See [Section 16.5.6](#).

The memory address to transfer to or from, depending on the PSR, must be written to the Memory Address Register (MAR). For each transfer the memory address is increased by either a one, two or four, depending on the size set in MR. See [Section 16.5.2](#).

The number of data items to transfer is written to the TCR register. If the PDCA channel is enabled, a transfer will start immediately after writing a non-zero value to TCR or the reload version of TCR, TCRR. After each transfer the TCR value is decreased by one. Both MAR and TCR can be read while the PDCA channel is active to monitor the DMA progress. See [Section 16.5.3](#).

The channel must be enabled for a transfer to start. A channel is enable by writing a one to the EN bit in the Control Register (CR).

16.5.2 Memory Pointer

Each channel has a 32-bit Memory Address Register (MAR). This register holds the memory address for the next transfer to be performed. The register is automatically updated after each transfer. The address will be increased by either one, two or four depending on the size of the DMA transfer (byte, halfword or word). The MAR can be read at any time during transfer.

16.5.3 Transfer Counter

Each channel has a 16-bit Transfer Counter Register (TCR). This register must be written with the number of transfers to be performed. The TCR register should contain the number of data items to be transferred independently of the transfer size. The TCR can be read at any time during transfer to see the number of remaining transfers.

16.5.4 Reload Registers

Both the MAR and the TCR have a reload register, respectively Memory Address Reload Register (MARR) and Transfer Counter Reload Register (TCRR). These registers provide the possibility for the PDCA to work on two memory buffers for each channel. When one buffer has completed, MAR and TCR will be reloaded with the values in MARR and TCRR. The reload logic is always enabled and will trigger if the TCR reaches zero while TCRR holds a non-zero value. After reload, the MARR and TCRR registers are cleared.

If TCR is zero when writing to TCRR, the TCR and MAR are automatically updated with the value written in TCRR and MARR.

16.5.5 Peripheral Selection

The Peripheral Select Register (PSR) decides which peripheral should be connected to the PDCA channel. A peripheral is selected by writing the corresponding Peripheral Identity (PID) to the PID field in the PSR register. Writing the PID will both select the direction of the transfer (memory to peripheral or peripheral to memory), which handshake interface to use, and the address of the peripheral holding register. Refer to the Peripheral Identity (PID) table in the Module Configuration section for the peripheral PID values.

16.5.6 Transfer Size

The transfer size can be set individually for each channel to be either byte, halfword or word (8-bit, 16-bit or 32-bit respectively). Transfer size is set by writing the desired value to the Transfer Size field in the Mode Register (MR.SIZE).

When the PDCA moves data between peripherals and memory, data is automatically sized and aligned. When memory is accessed, the size specified in MR.SIZE and system alignment is used. When a peripheral register is accessed the data to be transferred is converted to a word where bit *n* in the data corresponds to bit *n* in the peripheral register. If the transfer size is byte or halfword, bits greater than 8 and 16 respectively are set to zero.

Refer to the Module Configuration section for information regarding what peripheral registers are used for the different peripherals and then to the peripheral specific chapter for information about the size option available for the different registers.

16.5.7 Enabling and Disabling

Each DMA channel is enabled by writing a one to the Transfer Enable bit in the Control Register (CR.TEN) and disabled by writing a one to the Transfer Disable bit (CR.TDIS). The current status can be read from the Status Register (SR).

While the PDCA channel is enabled all DMA request will be handled as long the TCR and TCRR is not zero.

16.5.8 Interrupts

Interrupts can be enabled by writing a one to the corresponding bit in the Interrupt Enable Register (IER) and disabled by writing a one to the corresponding bit in the Interrupt Disable Register (IDR). The Interrupt Mask Register (IMR) can be read to see whether an interrupt is enabled or not. The current status of an interrupt source can be read through the Interrupt Status Register (ISR).

The PDCA has three interrupt sources:

- Reload Counter Zero - The TCRR register is zero.
- Transfer Finished - Both the TCR and TCRR registers are zero.
- Transfer Error - An error has occurred in accessing memory.

16.5.9 Priority

If more than one PDCA channel is requesting transfer at a given time, the PDCA channels are prioritized by their channel number. Channels with lower numbers have priority over channels with higher numbers, giving channel zero the highest priority.

16.5.10 Error Handling

If the Memory Address Register (MAR) is set to point to an invalid location in memory, an error will occur when the PDCA tries to perform a transfer. When an error occurs, the Transfer Error

bit in the Interrupt Status Register (ISR.TERR) will be set and the DMA channel that caused the error will be stopped. In order to restart the channel, the user must program the Memory Address Register to a valid address and then write a one to the Error Clear bit in the Control Register (CR.ECLR). If the Transfer Error interrupt is enabled, an interrupt request will be generated when a transfer error occurs.

16.6 User Interface

16.6.1 Memory Map Overview

Table 16-1. PDCA Register Memory Map

| Address Range | Contents |
|-------------------------|---------------------------------------|
| 0x000 - 0x03F | DMA channel 0 configuration registers |
| 0x040 - 0x07F | DMA channel 1 configuration registers |
| ... | ... |
| (0x000 - 0x03F)+m*0x040 | DMA channel m configuration registers |

The channels are mapped as shown in [Table 16-1](#). Each channel has a set of configuration registers, shown in [Table 16-2](#), where n is the channel number.

16.6.2 Channel Memory Map

Table 16-2. PDCA Channel Configuration Registers

| Offset | Register | Register Name | Access | Reset |
|-----------------|----------------------------------|---------------|------------|------------------|
| 0x000 + n*0x040 | Memory Address Register | MAR | Read/Write | 0x00000000 |
| 0x004 + n*0x040 | Peripheral Select Register | PSR | Read/Write | - ⁽¹⁾ |
| 0x008 + n*0x040 | Transfer Counter Register | TCR | Read/Write | 0x00000000 |
| 0x00C + n*0x040 | Memory Address Reload Register | MARR | Read/Write | 0x00000000 |
| 0x010 + n*0x040 | Transfer Counter Reload Register | TCRR | Read/Write | 0x00000000 |
| 0x014 + n*0x040 | Control Register | CR | Write-only | 0x00000000 |
| 0x018 + n*0x040 | Mode Register | MR | Read/Write | 0x00000000 |
| 0x01C + n*0x040 | Status Register | SR | Read-only | 0x00000000 |
| 0x020 + n*0x040 | Interrupt Enable Register | IER | Write-only | 0x00000000 |
| 0x024 + n*0x040 | Interrupt Disable Register | IDR | Write-only | 0x00000000 |
| 0x028 + n*0x040 | Interrupt Mask Register | IMR | Read-only | 0x00000000 |
| 0x02C + n*0x040 | Interrupt Status Register | ISR | Read-only | 0x00000000 |

Note: 1. The reset values are device specific. Please refer to the Module Configuration section at the end of this chapter.

Note: 1. The reset values are device specific. Please refer to the Module Configuration section at the end of this chapter.

16.6.3 Memory Address Register

Name: MAR
Access Type: Read/Write
Offset: 0x000 + n*0x040
Reset Value: 0x00000000

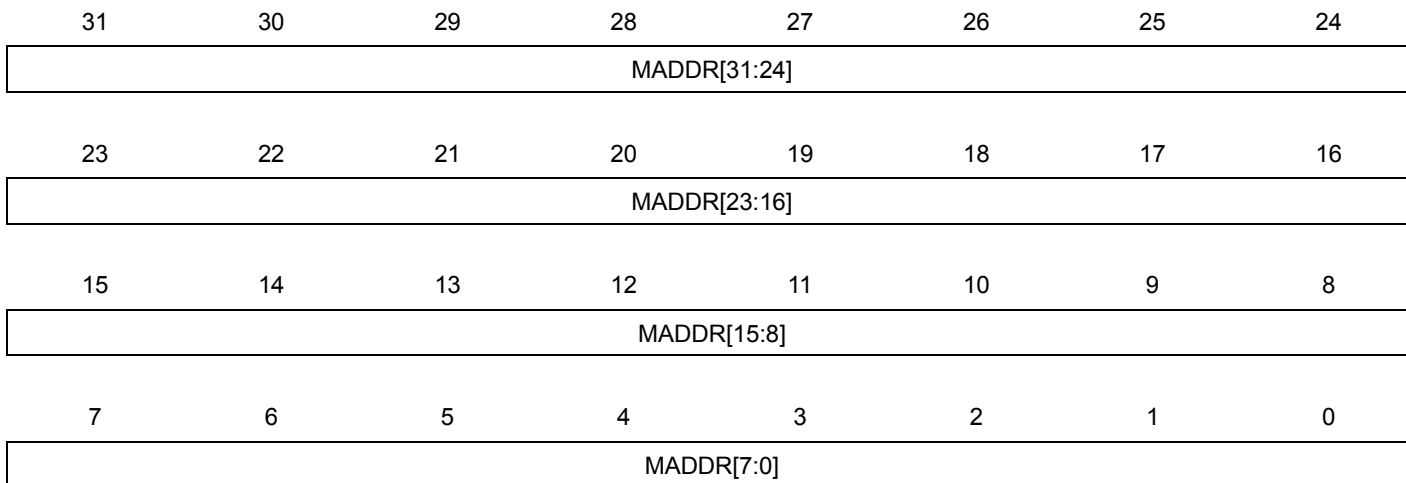

- **MADDR: Memory Address**
 Address of memory buffer. MADDR should be programmed to point to the start of the memory buffer when configuring the PDCA. During transfer, MADDR will point to the next memory location to be read/written.

16.6.4 Peripheral Select Register

Name: PSR
Access Type: Read/Write
Offset: 0x004 + n*0x040
Reset Value: -

| | | | | | | | |
|-----|----|----|----|----|----|----|----|
| 31 | 30 | 29 | 28 | 27 | 26 | 25 | 24 |
| - | - | - | - | - | - | - | - |
| 23 | 22 | 21 | 20 | 19 | 18 | 17 | 16 |
| - | - | - | - | - | - | - | - |
| 15 | 14 | 13 | 12 | 11 | 10 | 9 | 8 |
| - | - | - | - | - | - | - | - |
| 7 | 6 | 5 | 4 | 3 | 2 | 1 | 0 |
| PID | | | | | | | |

- **PID: Peripheral Identifier**

The Peripheral Identifier selects which peripheral should be connected to the DMA channel. Writing a PID will select both which handshake interface to use, the direction of the transfer and also the address of the Receive/Transfer Holding Register for the peripheral. See the Module Configuration section of PDCA for details. The width of the PID field is device specific and dependent on the number of peripheral modules in the device.

16.6.5 Transfer Counter Register

Name: TCR
Access Type: Read/Write
Offset: 0x008 + n*0x040
Reset Value: 0x00000000

| | | | | | | | |
|-----------|----|----|----|----|----|----|----|
| 31 | 30 | 29 | 28 | 27 | 26 | 25 | 24 |
| - | - | - | - | - | - | - | - |
| 23 | 22 | 21 | 20 | 19 | 18 | 17 | 16 |
| - | - | - | - | - | - | - | - |
| 15 | 14 | 13 | 12 | 11 | 10 | 9 | 8 |
| TCV[15:8] | | | | | | | |
| 7 | 6 | 5 | 4 | 3 | 2 | 1 | 0 |
| TCV[7:0] | | | | | | | |

- **TCV: Transfer Counter Value**

Number of data items to be transferred by the PDCA. TCV must be programmed with the total number of transfers to be made. During transfer, TCV contains the number of remaining transfers to be done.

16.6.6 Memory Address Reload Register

Name: MARR
Access Type: Read/Write
Offset: 0x00C + n*0x040
Reset Value: 0x00000000

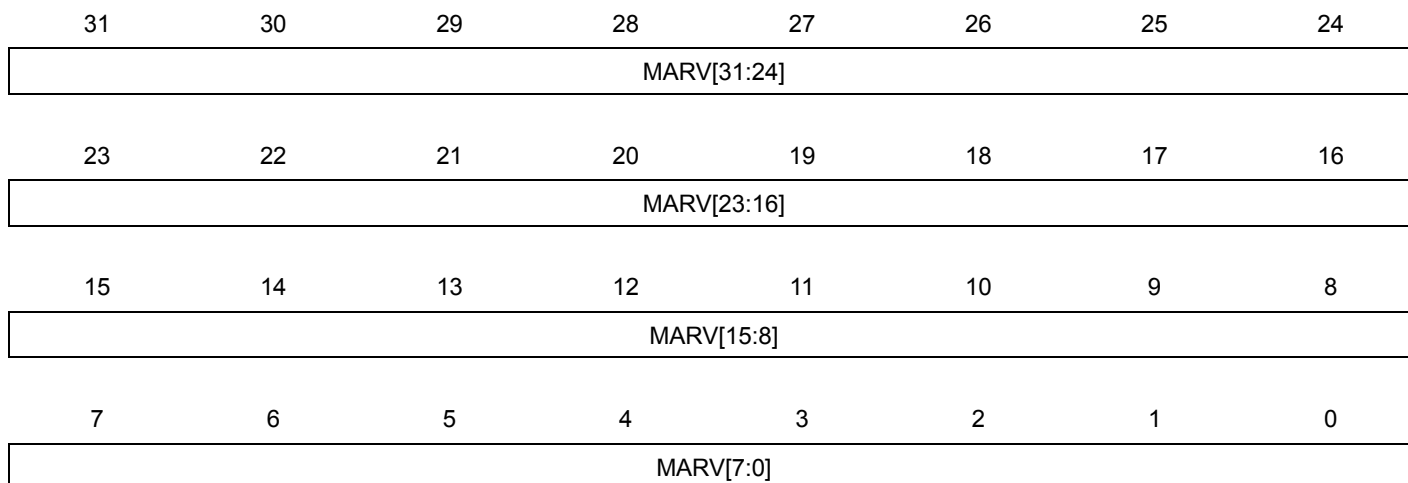

- **MARV: Memory Address Reload Value**

Reload Value for the MAR register. This value will be loaded into MAR when TCR reaches zero if the TCRR register has a non-zero value.

16.6.7 Transfer Counter Reload Register

Name: TCRR
Access Type: Read/Write
Offset: 0x010 + n*0x040
Reset Value: 0x00000000

| | | | | | | | |
|------------|----|----|----|----|----|----|----|
| 31 | 30 | 29 | 28 | 27 | 26 | 25 | 24 |
| - | - | - | - | - | - | - | - |
| 23 | 22 | 21 | 20 | 19 | 18 | 17 | 16 |
| - | - | - | - | - | - | - | - |
| 15 | 14 | 13 | 12 | 11 | 10 | 9 | 8 |
| TCRV[15:8] | | | | | | | |
| 7 | 6 | 5 | 4 | 3 | 2 | 1 | 0 |
| TCRV[7:0] | | | | | | | |

- **TCRV: Transfer Counter Reload Value**

Reload value for the TCR register. When TCR reaches zero, it will be reloaded with TCRV if TCRV has a positive value. If TCRV is zero, no more transfers will be performed for the channel. When TCR is reloaded, the TCRR register is cleared.

16.6.8 Control Register

Name: CR
Access Type: Write-only
Offset: 0x014 + n*0x040
Reset Value: 0x00000000

| | | | | | | | |
|----|----|----|----|----|----|------|------|
| 31 | 30 | 29 | 28 | 27 | 26 | 25 | 24 |
| - | - | - | - | - | - | - | - |
| 23 | 22 | 21 | 20 | 19 | 18 | 17 | 16 |
| - | - | - | - | - | - | - | - |
| 15 | 14 | 13 | 12 | 11 | 10 | 9 | 8 |
| - | - | - | - | - | - | - | ECLR |
| 7 | 6 | 5 | 4 | 3 | 2 | 1 | 0 |
| - | - | - | - | - | - | TDIS | TEN |

- ECLR: Transfer Error Clear**
 Writing a zero to this bit has no effect.
 Writing a one to this bit will clear the Transfer Error bit in the Status Register (SR.TERR). Clearing the SR.TERR bit will allow the channel to transmit data. The memory address must first be set to point to a valid location.
- TDIS: Transfer Disable**
 Writing a zero to this bit has no effect.
 Writing a one to this bit will disable transfer for the DMA channel.
- TEN: Transfer Enable**
 Writing a zero to this bit has no effect.
 Writing a one to this bit will enable transfer for the DMA channel.

16.6.9 Mode Register

Name: MR
Access Type: Read/Write
Offset: 0x018 + n*0x040
Reset Value: 0x00000000

| | | | | | | | |
|----|----|----|----|----|----|------|----|
| 31 | 30 | 29 | 28 | 27 | 26 | 25 | 24 |
| - | - | - | - | - | - | - | - |
| 23 | 22 | 21 | 20 | 19 | 18 | 17 | 16 |
| - | - | - | - | - | - | - | - |
| 15 | 14 | 13 | 12 | 11 | 10 | 9 | 8 |
| - | - | - | - | - | - | - | - |
| 7 | 6 | 5 | 4 | 3 | 2 | 1 | 0 |
| - | - | - | - | - | - | SIZE | |

• **SIZE: Size of Transfer**

Table 16-3. Size of Transfer

| SIZE | Size of Transfer |
|------|------------------|
| 0 | Byte |
| 1 | Halfword |
| 2 | Word |
| 3 | Reserved |

16.6.10 Status Register

Name: SR
Access Type: Read-only
Offset: 0x01C + n*0x040
Reset Value: 0x00000000

| | | | | | | | |
|----|----|----|----|----|----|----|-----|
| 31 | 30 | 29 | 28 | 27 | 26 | 25 | 24 |
| - | - | - | - | - | - | - | - |
| 23 | 22 | 21 | 20 | 19 | 18 | 17 | 16 |
| - | - | - | - | - | - | - | - |
| 15 | 14 | 13 | 12 | 11 | 10 | 9 | 8 |
| - | - | - | - | - | - | - | - |
| 7 | 6 | 5 | 4 | 3 | 2 | 1 | 0 |
| - | - | - | - | - | - | - | TEN |

- **TEN: Transfer Enabled**

This bit is cleared when the TDIS bit in CR is written to one.

This bit is set when the TEN bit in CR is written to one.

0: Transfer is disabled for the DMA channel.

1: Transfer is enabled for the DMA channel.

16.6.11 Interrupt Enable Register

Name: IER
Access Type: Write-only
Offset: 0x020 + n*0x040
Reset Value: 0x00000000

| | | | | | | | |
|----|----|----|----|----|------|-----|-----|
| 31 | 30 | 29 | 28 | 27 | 26 | 25 | 24 |
| - | - | - | - | - | - | - | - |
| 23 | 22 | 21 | 20 | 19 | 18 | 17 | 16 |
| - | - | - | - | - | - | - | - |
| 15 | 14 | 13 | 12 | 11 | 10 | 9 | 8 |
| - | - | - | - | - | - | - | - |
| 7 | 6 | 5 | 4 | 3 | 2 | 1 | 0 |
| - | - | - | - | - | TERR | TRC | RCZ |

Writing a zero to a bit in this register has no effect.

Writing a one to a bit in this register will set the corresponding bit in IMR.

16.6.12 Interrupt Disable Register

Name: IDR
Access Type: Write-only
Offset: 0x024 + n*0x040
Reset Value: 0x00000000

| | | | | | | | |
|----|----|----|----|----|------|-----|-----|
| 31 | 30 | 29 | 28 | 27 | 26 | 25 | 24 |
| - | - | - | - | - | - | - | - |
| 23 | 22 | 21 | 20 | 19 | 18 | 17 | 16 |
| - | - | - | - | - | - | - | - |
| 15 | 14 | 13 | 12 | 11 | 10 | 9 | 8 |
| - | - | - | - | - | - | - | - |
| 7 | 6 | 5 | 4 | 3 | 2 | 1 | 0 |
| - | - | - | - | - | TERR | TRC | RCZ |

Writing a zero to a bit in this register has no effect.

Writing a one to a bit in this register will clear the corresponding bit in IMR.

16.6.13 Interrupt Mask Register

Name: IMR
Access Type: Read-only
Offset: 0x028 + n*0x040
Reset Value: 0x00000000

| | | | | | | | |
|----|----|----|----|----|------|-----|-----|
| 31 | 30 | 29 | 28 | 27 | 26 | 25 | 24 |
| - | - | - | - | - | - | - | - |
| 23 | 22 | 21 | 20 | 19 | 18 | 17 | 16 |
| - | - | - | - | - | - | - | - |
| 15 | 14 | 13 | 12 | 11 | 10 | 9 | 8 |
| - | - | - | - | - | - | - | - |
| 7 | 6 | 5 | 4 | 3 | 2 | 1 | 0 |
| - | - | - | - | - | TERR | TRC | RCZ |

0: The corresponding interrupt is disabled.

1: The corresponding interrupt is enabled.

A bit in this register is cleared when the corresponding bit in IDR is written to one.

A bit in this register is set when the corresponding bit in IER is written to one.

16.6.14 Interrupt Status Register

Name: ISR
Access Type: Read-only
Offset: 0x02C + n*0x040
Reset Value: 0x00000000

| | | | | | | | |
|----|----|----|----|----|------|-----|-----|
| 31 | 30 | 29 | 28 | 27 | 26 | 25 | 24 |
| - | - | - | - | - | - | - | - |
| 23 | 22 | 21 | 20 | 19 | 18 | 17 | 16 |
| - | - | - | - | - | - | - | - |
| 15 | 14 | 13 | 12 | 11 | 10 | 9 | 8 |
| - | - | - | - | - | - | - | - |
| 7 | 6 | 5 | 4 | 3 | 2 | 1 | 0 |
| - | - | - | - | - | TERR | TRC | RCZ |

- **TERR: Transfer Error**
 This bit is cleared when no transfer errors have occurred since the last write to CR.ECLR.
 This bit is set when one or more transfer errors has occurred since reset or the last write to CR.ECLR.
- **TRC: Transfer Complete**
 This bit is cleared when the TCR and/or the TCRR holds a non-zero value.
 This bit is set when both the TCR and the TCRR are zero.
- **RCZ: Reload Counter Zero**
 This bit is cleared when the TCRR holds a non-zero value.
 This bit is set when TCRR is zero.
-

16.7 Module Configuration

The specific configuration for the PDCA instance is listed in the following tables.

Table 16-4. PDCA Configuration

| Features | PDCA |
|--------------------|------|
| Number of channels | 7 |

Table 16-5. Register Reset Values

| Register | Reset Value |
|----------|-------------|
| PSRn | n |

16.7.1 DMA Handshake Signals

The following table defines the valid settings for the Peripheral Identifier (PID) in the PDCA Peripheral Select Register (PSR).

Table 16-6. PDCA Handshake Signals

| PID Value | Peripheral module & direction |
|-----------|-------------------------------|
| 0 | ADC |
| 1 | SSC - RX |
| 2 | USART0 - RX |
| 3 | USART1 - RX |
| 4 | USART2 - RX |
| 5 | TWI - RX |
| 6 | SPI0 - RX |
| 7 | SSC - TX |
| 8 | USART0 - TX |
| 9 | USART1 - TX |
| 10 | USART2 - TX |
| 11 | TWI - TX |
| 12 | SPI0 - TX |
| 13 | ABDAC - TX |

17. General-Purpose Input/Output Controller (GPIO)

Rev: 1.1.0.4

17.1 Features

Each I/O line of the GPIO features:

- Configurable pin-change, rising-edge or falling-edge interrupt on any I/O line
- A glitch filter providing rejection of pulses shorter than one clock cycle
- Input visibility and output control
- Multiplexing of up to four peripheral functions per I/O line
- Programmable internal pull-up resistor

17.2 Overview

The General Purpose Input/Output Controller manages the I/O pins of the microcontroller. Each I/O line may be dedicated as a general-purpose I/O or be assigned to a function of an embedded peripheral. This assures effective optimization of the pins of a product.

17.3 Block Diagram

Figure 17-1. GPIO Block Diagram

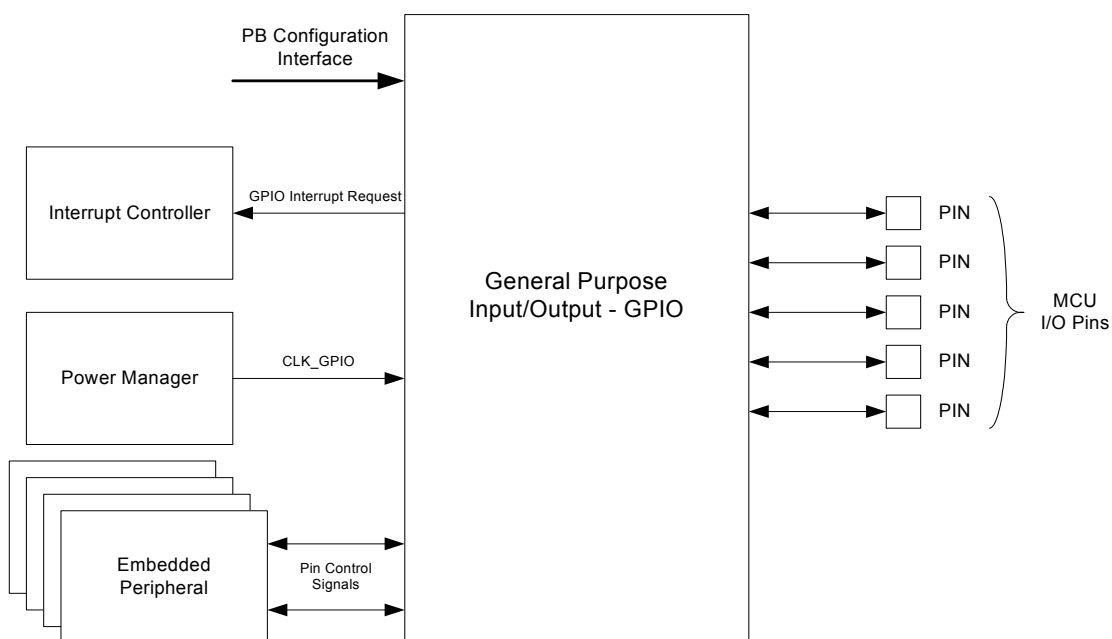

17.4 Product Dependencies

In order to use this module, other parts of the system must be configured correctly, as described below.

17.4.1 Module Configuration

Most of the features of the GPIO are configurable for each product. The user must refer to the Package and Pinout chapter for these settings.

Product specific settings includes:

- Number of I/O pins.
- Functions implemented on each pin
- Peripheral function(s) multiplexed on each I/O pin
- Reset value of registers

17.4.2 Clocks

The clock for the GPIO bus interface (CLK_GPIO) is generated by the Power Manager. This clock is enabled at reset, and can be disabled in the Power Manager.

The CLK_GPIO must be enabled in order to access the configuration registers of the GPIO or to use the GPIO interrupts. After configuring the GPIO, the CLK_GPIO can be disabled if interrupts are not used.

17.4.3 Interrupts

The GPIO interrupt lines are connected to the interrupt controller. Using the GPIO interrupt requires the interrupt controller to be configured first.

17.5 Functional Description

The GPIO controls the I/O lines of the microcontroller. The control logic associated with each pin is represented in the figure below:

Figure 17-2. Overview of the GPIO Pad Connections

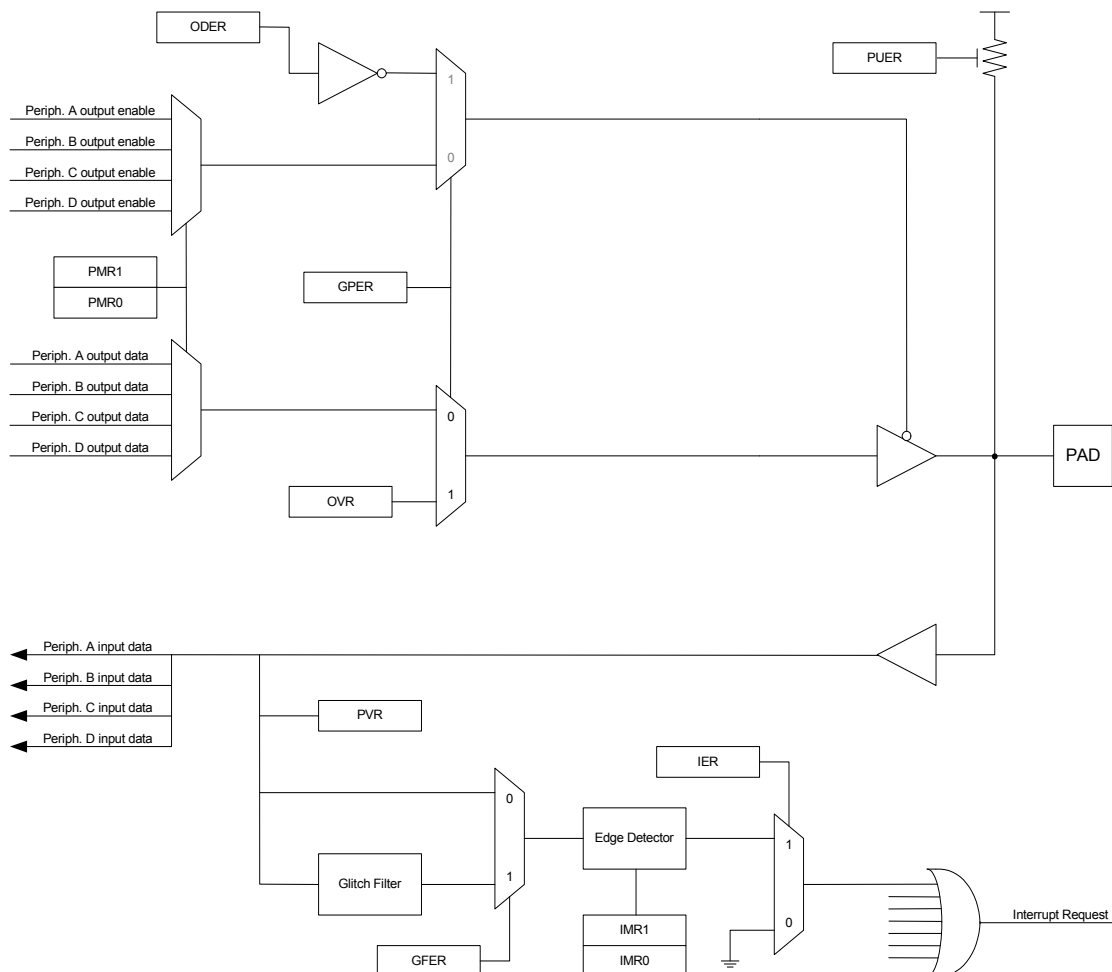

17.5.1 Basic Operation

17.5.1.1 I/O Line or peripheral function selection

When a pin is multiplexed with one or more peripheral functions, the selection is controlled with the GPIO Enable Register (GPER). If a bit in GPER is written to one, the corresponding pin is controlled by the GPIO. If a bit is written to zero, the corresponding pin is controlled by a peripheral function.

17.5.1.2 Peripheral selection

The GPIO provides multiplexing of up to four peripheral functions on a single pin. The selection is performed by accessing Peripheral Mux Register 0 (PMR0) and Peripheral Mux Register 1 (PMR1).

17.5.1.3 Output control

When the I/O line is assigned to a peripheral function, i.e. the corresponding bit in GPER is written to zero, the drive of the I/O line is controlled by the peripheral. The peripheral, depending on the value in PMR0 and PMR1, determines whether the pin is driven or not.

When the I/O line is controlled by the GPIO, the value of the Output Driver Enable Register (ODER) determines if the pin is driven or not. When a bit in this register is written to one, the cor-

responding I/O line is driven by the GPIO. When the bit is written to zero, the GPIO does not drive the line.

The level driven on an I/O line can be determined by writing to the Output Value Register (OVR).

17.5.1.4 Inputs

The level on each I/O line can be read through the Pin Value Register (PVR). This register indicates the level of the I/O lines regardless of whether the lines are driven by the GPIO or by an external component. Note that due to power saving measures, the PVR register can only be read when GPER is written to one for the corresponding pin or if interrupt is enabled for the pin.

17.5.1.5 Output line timings

The figure below shows the timing of the I/O line when writing a one and a zero to OVR. The same timing applies when performing a 'set' or 'clear' access, i.e., writing a one to the Output Value Set Register (OVRS) or the Output Value Clear Register (OVRCL). The timing of PVR is also shown.

Figure 17-3. Output Line Timings

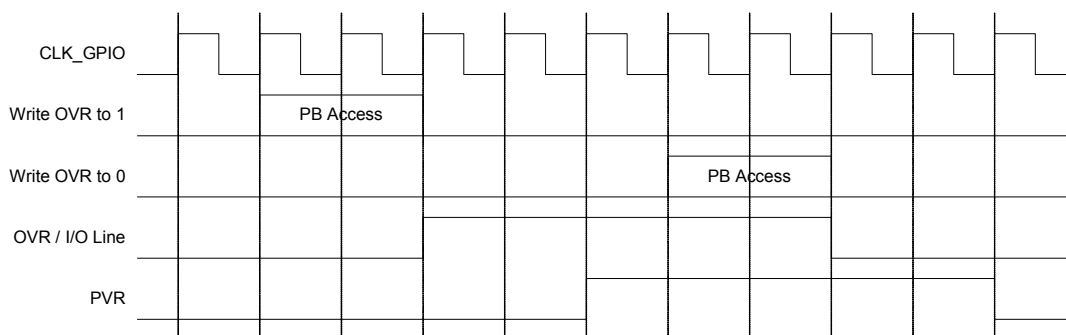

17.5.2 Advanced Operation

17.5.2.1 Pull-up resistor control

Each I/O line is designed with an embedded pull-up resistor. The pull-up resistor can be enabled or disabled by writing a one or a zero to the corresponding bit in the Pull-up Enable Register (PUER). Control of the pull-up resistor is possible whether an I/O line is controlled by a peripheral or the GPIO.

17.5.2.2 Input glitch filter

Optional input glitch filters can be enabled on each I/O line. When the glitch filter is enabled, a glitch with duration of less than 1 clock cycle is automatically rejected, while a pulse with duration of 2 clock cycles or more is accepted. For pulse durations between 1 clock cycle and 2 clock cycles, the pulse may or may not be taken into account, depending on the precise timing of its occurrence. Thus for a pulse to be guaranteed visible it must exceed 2 clock cycles, whereas for a glitch to be reliably filtered out, its duration must not exceed 1 clock cycle. The filter introduces 2 clock cycles of latency.

The glitch filters are controlled by the Glitch Filter Enable Register (GFER). When a bit is written to one in GFER, the glitch filter on the corresponding pin is enabled. The glitch filter affects only interrupt inputs. Inputs to peripherals or the value read through PVR are not affected by the glitch filters.

17.5.3 Interrupts

The GPIO can be configured to generate an interrupt when it detects an input change on an I/O line. The module can be configured to signal an interrupt whenever a pin changes value or only to trigger on rising edges or falling edges. Interrupts are enabled on a pin by writing a one to the corresponding bit in the Interrupt Enable Register (IER). The interrupt mode is set by writing to the Interrupt Mode Register 0 (IMR0) and the Interrupt Mode Register 1 (IMR1). Interrupts can be enabled on a pin, regardless of the configuration of the I/O line, i.e. whether it is controlled by the GPIO or assigned to a peripheral function.

In every port there are four interrupt lines connected to the interrupt controller. Groups of eight interrupts in the port are ORed together to form an interrupt line.

When an interrupt event is detected on an I/O line, and the corresponding bit in IER is written to one, the GPIO interrupt request line is asserted. A number of interrupt signals are ORed-wired together to generate a single interrupt signal to the interrupt controller.

The Interrupt Flag Register (IFR) can be read to determine which pin(s) caused the interrupt. The interrupt bit must be cleared by writing a one to the Interrupt Flag Clear Register (IFRC). To take effect, the clear operation must be performed when the interrupt line is enabled in IER. Otherwise, it will be ignored.

GPIO interrupts can only be triggered when the CLK_GPIO is enabled.

17.5.4 Interrupt Timings

The figure below shows the timing for rising edge (or pin-change) interrupts when the glitch filter is disabled. For the pulse to be registered, it must be sampled at the rising edge of the clock. In this example, this is not the case for the first pulse. The second pulse is however sampled on a rising edge and will trigger an interrupt request.

Figure 17-4. Interrupt Timing With Glitch Filter Disabled

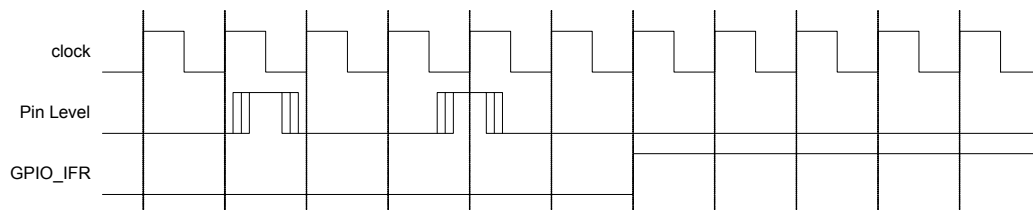

The figure below shows the timing for rising edge (or pin-change) interrupts when the glitch filter is enabled. For the pulse to be registered, it must be sampled on two subsequent rising edges. In the example, the first pulse is rejected while the second pulse is accepted and causes an interrupt request.

Figure 17-5. Interrupt Timing With Glitch Filter Enabled

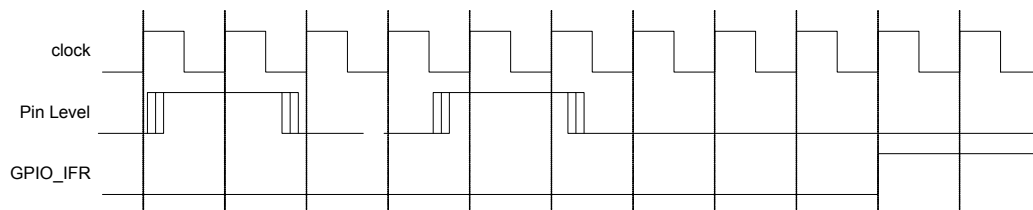

17.6 User Interface

The GPIO controls all the I/O pins on the AVR32 microcontroller. The pins are managed as 32-bit ports that are configurable through a PB interface. Each port has a set of configuration registers. The overall memory map of the GPIO is shown below. The number of pins and hence the number of ports are product specific.

Figure 17-6. Overall Memory Map

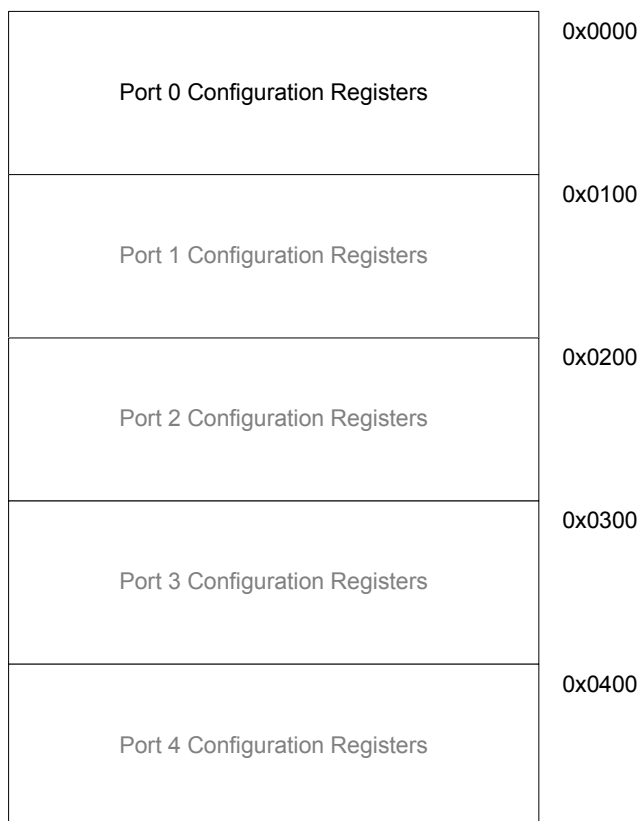

In the GPIO Controller Function Multiplexing table in the Package and Pinout chapter, each GPIO line has a unique number. Note that the PA, PB, PC and PX ports do not directly correspond to the GPIO ports. To find the corresponding port and pin the following formula can be used:

GPIO port = $\text{floor}(\text{GPIO number} / 32)$, example: $\text{floor}((36)/32) = 1$

GPIO pin = $\text{GPIO number} \bmod 32$, example: $36 \bmod 32 = 4$

The table below shows the configuration registers for one port. Addresses shown are relative to the port address offset. The specific address of a configuration register is found by adding the

register offset and the port offset to the GPIO start address. One bit in each of the configuration registers corresponds to an I/O pin.

Table 17-1. GPIO Register Memory Map

| Offset | Register | Function | Name | Access | Reset value |
|--------|-------------------------------|------------|-------|------------|-------------|
| 0x00 | GPIO Enable Register | Read/Write | GPER | Read/Write | (1) |
| 0x04 | GPIO Enable Register | Set | GPERS | Write-Only | |
| 0x08 | GPIO Enable Register | Clear | GPERC | Write-Only | |
| 0x0C | GPIO Enable Register | Toggle | GPERT | Write-Only | |
| 0x10 | Peripheral Mux Register 0 | Read/Write | PMR0 | Read/Write | (1) |
| 0x14 | Peripheral Mux Register 0 | Set | PMR0S | Write-Only | |
| 0x18 | Peripheral Mux Register 0 | Clear | PMR0C | Write-Only | |
| 0x1C | Peripheral Mux Register 0 | Toggle | PMR0T | Write-Only | |
| 0x20 | Peripheral Mux Register 1 | Read/Write | PMR1 | Read/Write | (1) |
| 0x24 | Peripheral Mux Register 1 | Set | PMR1S | Write-Only | |
| 0x28 | Peripheral Mux Register 1 | Clear | PMR1C | Write-Only | |
| 0x2C | Peripheral Mux Register 1 | Toggle | PMR1T | Write-Only | |
| 0x40 | Output Driver Enable Register | Read/Write | ODER | Read/Write | (1) |
| 0x44 | Output Driver Enable Register | Set | ODERS | Write-Only | |
| 0x48 | Output Driver Enable Register | Clear | ODERC | Write-Only | |
| 0x4C | Output Driver Enable Register | Toggle | ODERT | Write-Only | |
| 0x50 | Output Value Register | Read/Write | OVR | Read/Write | (1) |
| 0x54 | Output Value Register | Set | OVRS | Write-Only | |
| 0x58 | Output Value Register | Clear | OVRC | Write-Only | |
| 0x5c | Output Value Register | Toggle | OVRT | Write-Only | |
| 0x60 | Pin Value Register | Read | PVR | Read-Only | (2) |
| 0x70 | Pull-up Enable Register | Read/Write | PUER | Read/Write | (1) |
| 0x74 | Pull-up Enable Register | Set | PUERS | Write-Only | |
| 0x78 | Pull-up Enable Register | Clear | PUERC | Write-Only | |
| 0x7C | Pull-up Enable Register | Toggle | PUERT | Write-Only | |
| 0x90 | Interrupt Enable Register | Read/Write | IER | Read/Write | (1) |
| 0x94 | Interrupt Enable Register | Set | IERS | Write-Only | |
| 0x98 | Interrupt Enable Register | Clear | IERC | Write-Only | |
| 0x9C | Interrupt Enable Register | Toggle | IERT | Write-Only | |
| 0xA0 | Interrupt Mode Register 0 | Read/Write | IMR0 | Read/Write | (1) |
| 0xA4 | Interrupt Mode Register 0 | Set | IMR0S | Write-Only | |
| 0xA8 | Interrupt Mode Register 0 | Clear | IMR0C | Write-Only | |
| 0xAC | Interrupt Mode Register 0 | Toggle | IMR0T | Write-Only | |
| 0xB0 | Interrupt Mode Register 1 | Read/Write | IMR1 | Read/Write | (1) |

Table 17-1. GPIO Register Memory Map

| Offset | Register | Function | Name | Access | Reset value |
|--------|-------------------------------|------------|-------|------------|-------------|
| 0xB4 | Interrupt Mode Register 1 | Set | IMR1S | Write-Only | |
| 0xB8 | Interrupt Mode Register 1 | Clear | IMR1C | Write-Only | |
| 0xBC | Interrupt Mode Register 1 | Toggle | IMR1T | Write-Only | |
| 0xC0 | Glitch Filter Enable Register | Read/Write | GFER | Read/Write | (1) |
| 0xC4 | Glitch Filter Enable Register | Set | GFERS | Write-Only | |
| 0xC8 | Glitch Filter Enable Register | Clear | GFERC | Write-Only | |
| 0xCC | Glitch Filter Enable Register | Toggle | GFERT | Write-Only | |
| 0xD0 | Interrupt Flag Register | Read | IFR | Read-Only | (1) |
| 0xD4 | Interrupt Flag Register | - | - | - | |
| 0xD8 | Interrupt Flag Register | Clear | IFRC | Write-Only | |
| 0xDC | Interrupt Flag Register | - | - | - | |

- 1) The reset value for these registers are device specific. Please refer to the Module Configuration section at the end of this chapter.
- 2) The reset value is undefined depending on the pin states.

17.6.1 Access Types

Each configuration register can be accessed in four different ways. The first address location can be used to write the register directly. This address can also be used to read the register value. The following addresses facilitate three different types of write access to the register. Performing a “set” access, all bits written to one will be set. Bits written to zero will be unchanged by the operation. Performing a “clear” access, all bits written to one will be cleared. Bits written to zero will be unchanged by the operation. Finally, a toggle access will toggle the value of all bits written to one. Again all bits written to zero remain unchanged. Note that for some registers (e.g. IFR), not all access methods are permitted.

Note that for ports with less than 32 bits, the corresponding control registers will have unused bits. This is also the case for features that are not implemented for a specific pin. Writing to an unused bit will have no effect. Reading unused bits will always return 0.

17.6.2 Enable Register

Name: GPER

Access Type: Read, Write, Set, Clear, Toggle

Offset: 0x00, 0x04, 0x08, 0x0C

Reset Value: -

| | | | | | | | |
|-----|-----|-----|-----|-----|-----|-----|-----|
| 31 | 30 | 29 | 28 | 27 | 26 | 25 | 24 |
| P31 | P30 | P29 | P28 | P27 | P26 | P25 | P24 |
| 23 | 22 | 21 | 20 | 19 | 18 | 17 | 16 |
| P23 | P22 | P21 | P20 | P19 | P18 | P17 | P16 |
| 15 | 14 | 13 | 12 | 11 | 10 | 9 | 8 |
| P15 | P14 | P13 | P12 | P11 | P10 | P9 | P8 |
| 7 | 6 | 5 | 4 | 3 | 2 | 1 | 0 |
| P7 | P6 | P5 | P4 | P3 | P2 | P1 | P0 |

- **P0-P31: Pin Enable**

0: A peripheral function controls the corresponding pin.

1: The GPIO controls the corresponding pin.

17.6.3 Peripheral Mux Register 0

Name: PMR0

Access Type: Read, Write, Set, Clear, Toggle

Offset: 0x10, 0x14, 0x18, 0x1C

Reset Value: -

| | | | | | | | |
|-----|-----|-----|-----|-----|-----|-----|-----|
| 31 | 30 | 29 | 28 | 27 | 26 | 25 | 24 |
| P31 | P30 | P29 | P28 | P27 | P26 | P25 | P24 |
| 23 | 22 | 21 | 20 | 19 | 18 | 17 | 16 |
| P23 | P22 | P21 | P20 | P19 | P18 | P17 | P16 |
| 15 | 14 | 13 | 12 | 11 | 10 | 9 | 8 |
| P15 | P14 | P13 | P12 | P11 | P10 | P9 | P8 |
| 7 | 6 | 5 | 4 | 3 | 2 | 1 | 0 |
| P7 | P6 | P5 | P4 | P3 | P2 | P1 | P0 |

- **P0-31: Peripheral Multiplexer Select bit 0**

17.6.4 Peripheral Mux Register 1

Name: PMR1

Access Type: Read, Write, Set, Clear, Toggle

Offset: 0x20, 0x24, 0x28, 0x2C

Reset Value: -

| | | | | | | | |
|-----|-----|-----|-----|-----|-----|-----|-----|
| 31 | 30 | 29 | 28 | 27 | 26 | 25 | 24 |
| P31 | P30 | P29 | P28 | P27 | P26 | P25 | P24 |
| 23 | 22 | 21 | 20 | 19 | 18 | 17 | 16 |
| P23 | P22 | P21 | P20 | P19 | P18 | P17 | P16 |
| 15 | 14 | 13 | 12 | 11 | 10 | 9 | 8 |
| P15 | P14 | P13 | P12 | P11 | P10 | P9 | P8 |
| 7 | 6 | 5 | 4 | 3 | 2 | 1 | 0 |
| P7 | P6 | P5 | P4 | P3 | P2 | P1 | P0 |

- **P0-31: Peripheral Multiplexer Select bit 1**

| {PMR1, PMR0} | Selected Peripheral Function |
|--------------|------------------------------|
| 00 | A |
| 01 | B |
| 10 | C |
| 11 | D |

17.6.5 Output Driver Enable Register

Name: ODER

Access Type: Read, Write, Set, Clear, Toggle

Offset: 0x40, 0x44, 0x48, 0x4C

Reset Value: -

| | | | | | | | |
|-----|-----|-----|-----|-----|-----|-----|-----|
| 31 | 30 | 29 | 28 | 27 | 26 | 25 | 24 |
| P31 | P30 | P29 | P28 | P27 | P26 | P25 | P24 |
| 23 | 22 | 21 | 20 | 19 | 18 | 17 | 16 |
| P23 | P22 | P21 | P20 | P19 | P18 | P17 | P16 |
| 15 | 14 | 13 | 12 | 11 | 10 | 9 | 8 |
| P15 | P14 | P13 | P12 | P11 | P10 | P9 | P8 |
| 7 | 6 | 5 | 4 | 3 | 2 | 1 | 0 |
| P7 | P6 | P5 | P4 | P3 | P2 | P1 | P0 |

- **P0-31: Output Driver Enable**

0: The output driver is disabled for the corresponding pin.

1: The output driver is enabled for the corresponding pin.

17.6.6 Output Value Register

Name: OVR

Access Type: Read, Write, Set, Clear, Toggle

Offset: 0x50, 0x54, 0x58, 0x5C

Reset Value: -

| | | | | | | | |
|-----|-----|-----|-----|-----|-----|-----|-----|
| 31 | 30 | 29 | 28 | 27 | 26 | 25 | 24 |
| P31 | P30 | P29 | P28 | P27 | P26 | P25 | P24 |
| 23 | 22 | 21 | 20 | 19 | 18 | 17 | 16 |
| P23 | P22 | P21 | P20 | P19 | P18 | P17 | P16 |
| 15 | 14 | 13 | 12 | 11 | 10 | 9 | 8 |
| P15 | P14 | P13 | P12 | P11 | P10 | P9 | P8 |
| 7 | 6 | 5 | 4 | 3 | 2 | 1 | 0 |
| P7 | P6 | P5 | P4 | P3 | P2 | P1 | P0 |

- **P0-31: Output Value**

0: The value to be driven on the I/O line is 0.

1: The value to be driven on the I/O line is 1.

17.6.7 Pin Value Register

Name: PVR

Access Type: Read

Offset: 0x60, 0x64, 0x68, 0x6C

Reset Value: -

| | | | | | | | |
|-----|-----|-----|-----|-----|-----|-----|-----|
| 31 | 30 | 29 | 28 | 27 | 26 | 25 | 24 |
| P31 | P30 | P29 | P28 | P27 | P26 | P25 | P24 |
| 23 | 22 | 21 | 20 | 19 | 18 | 17 | 16 |
| P23 | P22 | P21 | P20 | P19 | P18 | P17 | P16 |
| 15 | 14 | 13 | 12 | 11 | 10 | 9 | 8 |
| P15 | P14 | P13 | P12 | P11 | P10 | P9 | P8 |
| 7 | 6 | 5 | 4 | 3 | 2 | 1 | 0 |
| P7 | P6 | P5 | P4 | P3 | P2 | P1 | P0 |

- **P0-31: Pin Value**

0: The I/O line is at level '0'.

1: The I/O line is at level '1'.

Note that the level of a pin can only be read when GPER is set or interrupt is enabled for the pin.

17.6.8 Pull-up Enable Register

Name: PUER

Access Type: Read, Write, Set, Clear, Toggle

Offset: 0x70, 0x74, 0x78, 0x7C

Reset Value: -

| | | | | | | | |
|-----|-----|-----|-----|-----|-----|-----|-----|
| 31 | 30 | 29 | 28 | 27 | 26 | 25 | 24 |
| P31 | P30 | P29 | P28 | P27 | P26 | P25 | P24 |
| 23 | 22 | 21 | 20 | 19 | 18 | 17 | 16 |
| P23 | P22 | P21 | P20 | P19 | P18 | P17 | P16 |
| 15 | 14 | 13 | 12 | 11 | 10 | 9 | 8 |
| P15 | P14 | P13 | P12 | P11 | P10 | P9 | P8 |
| 7 | 6 | 5 | 4 | 3 | 2 | 1 | 0 |
| P7 | P6 | P5 | P4 | P3 | P2 | P1 | P0 |

- **P0-31: Pull-up Enable**

0: The internal pull-up resistor is disabled for the corresponding pin.

1: The internal pull-up resistor is enabled for the corresponding pin.

17.6.9 Interrupt Enable Register

Name: IER

Access Type: Read, Write, Set, Clear, Toggle

Offset: 0x90, 0x94, 0x98, 0x9C

Reset Value: -

| | | | | | | | |
|-----|-----|-----|-----|-----|-----|-----|-----|
| 31 | 30 | 29 | 28 | 27 | 26 | 25 | 24 |
| P31 | P30 | P29 | P28 | P27 | P26 | P25 | P24 |
| 23 | 22 | 21 | 20 | 19 | 18 | 17 | 16 |
| P23 | P22 | P21 | P20 | P19 | P18 | P17 | P16 |
| 15 | 14 | 13 | 12 | 11 | 10 | 9 | 8 |
| P15 | P14 | P13 | P12 | P11 | P10 | P9 | P8 |
| 7 | 6 | 5 | 4 | 3 | 2 | 1 | 0 |
| P7 | P6 | P5 | P4 | P3 | P2 | P1 | P0 |

- **P0-31: Interrupt Enable**

0: Interrupt is disabled for the corresponding pin.

1: Interrupt is enabled for the corresponding pin.

17.6.10 Interrupt Mode Register 0

Name: IMR0

Access Type: Read, Write, Set, Clear, Toggle

Offset: 0xA0, 0xA4, 0xA8, 0xAC

Reset Value: -

| | | | | | | | |
|-----|-----|-----|-----|-----|-----|-----|-----|
| 31 | 30 | 29 | 28 | 27 | 26 | 25 | 24 |
| P31 | P30 | P29 | P28 | P27 | P26 | P25 | P24 |
| 23 | 22 | 21 | 20 | 19 | 18 | 17 | 16 |
| P23 | P22 | P21 | P20 | P19 | P18 | P17 | P16 |
| 15 | 14 | 13 | 12 | 11 | 10 | 9 | 8 |
| P15 | P14 | P13 | P12 | P11 | P10 | P9 | P8 |
| 7 | 6 | 5 | 4 | 3 | 2 | 1 | 0 |
| P7 | P6 | P5 | P4 | P3 | P2 | P1 | P0 |

- **P0-31: Interrupt Mode Bit 0**

17.6.11 Interrupt Mode Register 1

Name: IMR1

Access Type: Read, Write, Set, Clear, Toggle

Offset: 0xB0, 0xB4, 0xB8, 0xBC

Reset Value: -

| | | | | | | | |
|-----|-----|-----|-----|-----|-----|-----|-----|
| 31 | 30 | 29 | 28 | 27 | 26 | 25 | 24 |
| P31 | P30 | P29 | P28 | P27 | P26 | P25 | P24 |
| 23 | 22 | 21 | 20 | 19 | 18 | 17 | 16 |
| P23 | P22 | P21 | P20 | P19 | P18 | P17 | P16 |
| 15 | 14 | 13 | 12 | 11 | 10 | 9 | 8 |
| P15 | P14 | P13 | P12 | P11 | P10 | P9 | P8 |
| 7 | 6 | 5 | 4 | 3 | 2 | 1 | 0 |
| P7 | P6 | P5 | P4 | P3 | P2 | P1 | P0 |

- **P0-31: Interrupt Mode Bit 1**

| {IMR1, IMR0} | Interrupt Mode |
|--------------|----------------|
| 00 | Pin Change |
| 01 | Rising Edge |
| 10 | Falling Edge |
| 11 | Reserved |

17.6.12 Glitch Filter Enable Register

Name: GFER

Access Type: Read, Write, Set, Clear, Toggle

Offset: 0xC0, 0xC4, 0xC8, 0xCC

Reset Value: -

| | | | | | | | |
|-----|-----|-----|-----|-----|-----|-----|-----|
| 31 | 30 | 29 | 28 | 27 | 26 | 25 | 24 |
| P31 | P30 | P29 | P28 | P27 | P26 | P25 | P24 |
| 23 | 22 | 21 | 20 | 19 | 18 | 17 | 16 |
| P23 | P22 | P21 | P20 | P19 | P18 | P17 | P16 |
| 15 | 14 | 13 | 12 | 11 | 10 | 9 | 8 |
| P15 | P14 | P13 | P12 | P11 | P10 | P9 | P8 |
| 7 | 6 | 5 | 4 | 3 | 2 | 1 | 0 |
| P7 | P6 | P5 | P4 | P3 | P2 | P1 | P0 |

- P0-31: Glitch Filter Enable**

0: Glitch filter is disabled for the corresponding pin.

1: Glitch filter is enabled for the corresponding pin.

NOTE! The value of this register should only be changed when IER is '0'. Updating this GFER while interrupt on the corresponding pin is enabled can cause an unintentional interrupt to be triggered.

17.6.13 Interrupt Flag Register

Name: IFR
Access Type: Read, Clear
Offset: 0xD0, 0xD8
Reset Value: -

| | | | | | | | |
|-----|-----|-----|-----|-----|-----|-----|-----|
| 31 | 30 | 29 | 28 | 27 | 26 | 25 | 24 |
| P31 | P30 | P29 | P28 | P27 | P26 | P25 | P24 |
| 23 | 22 | 21 | 20 | 19 | 18 | 17 | 16 |
| P23 | P22 | P21 | P20 | P19 | P18 | P17 | P16 |
| 15 | 14 | 13 | 12 | 11 | 10 | 9 | 8 |
| P15 | P14 | P13 | P12 | P11 | P10 | P9 | P8 |
| 7 | 6 | 5 | 4 | 3 | 2 | 1 | 0 |
| P7 | P6 | P5 | P4 | P3 | P2 | P1 | P0 |

- **P0-31: Interrupt Flag**

1: An interrupt condition has been detected on the corresponding pin.

0: No interrupt condition has been detected on the corresponding pin since reset or the last time it was cleared.

The number of interrupt request lines is dependant on the number of I/O pins on the MCU. Refer to the product specific data for details. Note also that a bit in the Interrupt Flag register is only valid if the corresponding bit in IER is set.

17.7 Programming Examples

17.7.1 8-bit LED-Chaser

```

// Set R0 to GPIO base address
mov    R0, LO(AVR32_GPIO_ADDRESS)
orh    R0, HI(AVR32_GPIO_ADDRESS)

// Enable GPIO control of pin 0-8
mov    R1, 0xFF
st.w   R0[AVR32_GPIO_GPERS], R1

// Set initial value of port
mov    R2, 0x01
st.w   R0[AVR32_GPIO_OVRS], R2

// Set up toggle value. Two pins are toggled
// in each round. The bit that is currently set,
// and the next bit to be set.
mov    R2, 0x0303
orh    R2, 0x0303

loop:
// Only change 8 LSB
mov    R3, 0x00FF
and    R3, R2
st.w   R0[AVR32_GPIO_OVRT], R3
rol    R2
rcall  delay
rjmp   loop

```

It is assumed in this example that a subroutine "delay" exists that returns after a given time.

17.7.2 Configuration of USART pins

The example below shows how to configure a peripheral module to control I/O pins. It is assumed in this example that the USART receive pin (RXD) is connected to PC16 and that the USART transmit pin (TXD) is connected to PC17. For both pins, the USART is peripheral B. In this example, the state of the GPIO registers is assumed to be unknown. The two USART pins are therefore first set to be controlled by the GPIO with output drivers disabled. The pins can then be assured to be tri-stated while changing the Peripheral Mux Registers.

```

// Set up pointer to GPIO, PORTC
mov    R0, LO(AVR32_GPIO_ADDRESS + PORTC_OFFSET)
orh    R0, HI(AVR32_GPIO_ADDRESS + PORTC_OFFSET)

// Disable output drivers

```

```
mov    R1, 0x0000
orh    R1, 0x0003
st.w   R0[AVR32_GPIO_ODERC], R1

// Make the GPIO control the pins
st.w   R0[AVR32_GPIO_GPERS], R1

// Select peripheral B on PC16-PC17
st.w   R0[AVR32_GPIO_PMR0S], R1
st.w   R0[AVR32_GPIO_PMR1C], R1

// Enable peripheral control
st.w   R0[AVR32_GPIO_GPERC], R1
```

17.8 Module Configuration

The specific configuration for each GPIO instance is listed in the following tables. The module bus clocks listed here are connected to the system bus clocks. Refer to the Power Manager chapter for details.

Table 17-2. Module Configuration

| Feature | GPIO |
|--------------------------------|------|
| Number of GPIO ports | 2 |
| Number of peripheral functions | 4 |

Table 17-3. Module Clock Name

| Module Name | Clock Name |
|-------------|------------|
| GPIO | CLK_GPIO |

The reset values for all GPIO registers are zero, with the following exceptions:

Table 17-4. Register Reset Values

| Port | Register | Reset Value |
|------|----------|-------------|
| 0 | GPER | 0xFFFFFFFF |
| 0 | PMR0 | 0x00000000 |
| 0 | PMR1 | 0x00000000 |
| 0 | ODER | 0x00000000 |
| 0 | OVR | 0x00000000 |
| 0 | PUER | 0x00000000 |
| 0 | IER | 0x00000000 |
| 0 | IMR0 | 0x00000000 |
| 0 | IMR1 | 0x00000000 |
| 0 | GFER | 0x00000000 |
| 0 | IFR | 0xFFFFFFFF |
| 1 | GPER | 0x00000FFF |
| 1 | PMR0 | 0x00000000 |
| 1 | PMR1 | 0x00000000 |
| 1 | ODER | 0x00000000 |
| 1 | OVR | 0x00000000 |
| 1 | PUER | 0x00000000 |
| 1 | IER | 0x00000000 |
| 1 | IMR0 | 0x00000000 |
| 1 | IMR1 | 0x00000000 |
| 1 | GFER | 0x00000000 |
| 1 | IFR | 0x00000FFF |

18. Serial Peripheral Interface (SPI)

Rev. 1.9.9.2

18.1 Features

- **Supports Communication with Serial External Devices**
 - Four Chip Selects with External Decoder Support Allow Communication with Up to 15 Peripherals
 - Serial Memories, such as DataFlash and 3-wire EEPROMs
 - Serial Peripherals, such as ADCs, DACs, LCD Controllers, CAN Controllers and Sensors
 - External Co-processors
- **Master or Slave Serial Peripheral Bus Interface**
 - 8 - to 16-bit Programmable Data Length Per Chip Select
 - Programmable Phase and Polarity Per Chip Select
 - Programmable Transfer Delays Between Consecutive Transfers and Between Clock and Data Per Chip Select
 - Programmable Delay Between Consecutive Transfers
 - Selectable Mode Fault Detection
- **Connection to PDCA Channel Capabilities Optimizes Data Transfers**
 - One Channel for the Receiver, One Channel for the Transmitter
 - Next Buffer Support

18.2 Overview

The Serial Peripheral Interface (SPI) circuit is a synchronous serial data link that provides communication with external devices in Master or Slave Mode. It also enables communication between processors if an external processor is connected to the system.

The Serial Peripheral Interface is essentially a shift register that serially transmits data bits to other SPIs. During a data transfer, one SPI system acts as the “master” which controls the data flow, while the other devices act as “slaves” which have data shifted into and out by the master. Different CPUs can take turn being masters (Multiple Master Protocol opposite to Single Master Protocol where one CPU is always the master while all of the others are always slaves) and one master may simultaneously shift data into multiple slaves. However, only one slave may drive its output to write data back to the master at any given time.

A slave device is selected when the master asserts its NSS signal. If multiple slave devices exist, the master generates a separate slave select signal for each slave (NPCS).

The SPI system consists of two data lines and two control lines:

- **Master Out Slave In (MOSI):** This data line supplies the output data from the master shifted into the input(s) of the slave(s).
- **Master In Slave Out (MISO):** This data line supplies the output data from a slave to the input of the master. There may be no more than one slave transmitting data during any particular transfer.
- **Serial Clock (SPCK):** This control line is driven by the master and regulates the flow of the data bits. The master may transmit data at a variety of baud rates; the SPCK line cycles once for each bit that is transmitted.
- **Slave Select (NSS):** This control line allows slaves to be turned on and off by hardware.

18.3 Block Diagram

Figure 18-1. Block Diagram

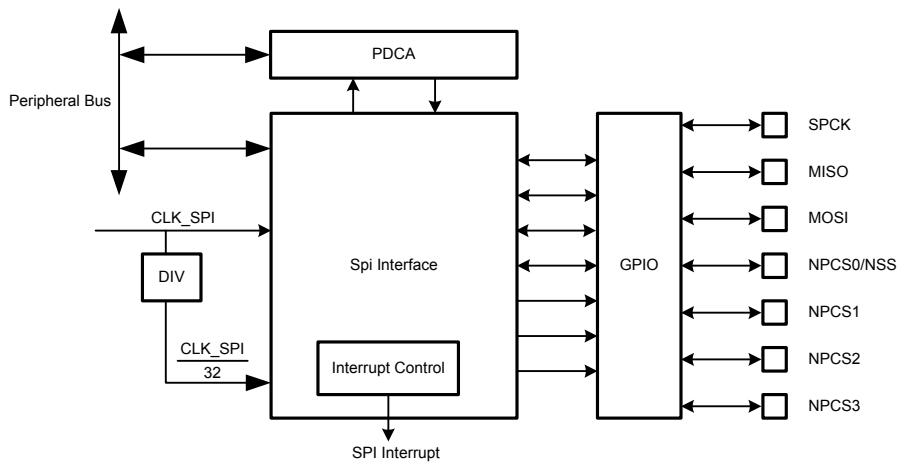

18.4 Application Block Diagram

Figure 18-2. Application Block Diagram: Single Master/Multiple Slave Implementation

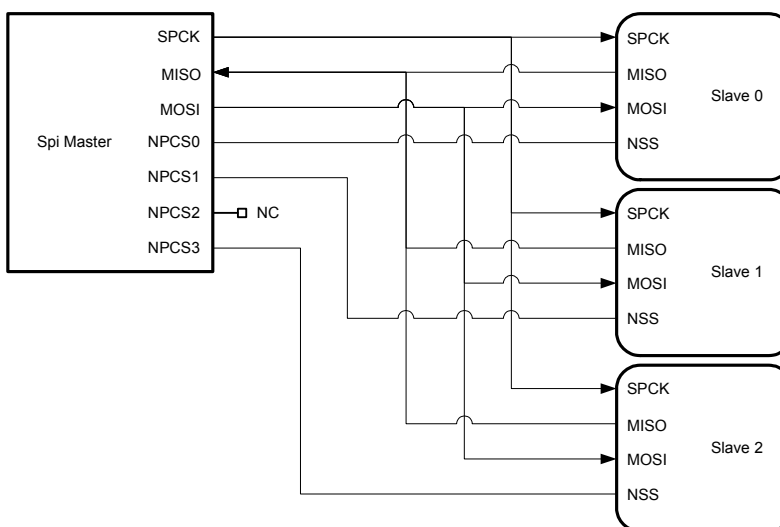

18.5 Signal Description

Table 18-1.

| Pin Name | Pin Description | Type | |
|-------------|-------------------------------------|--------|--------|
| | | Master | Slave |
| MISO | Master In Slave Out | Input | Output |
| MOSI | Master Out Slave In | Output | Input |
| SPCK | Serial Clock | Output | Input |
| NPCS1-NPCS3 | Peripheral Chip Selects | Output | Unused |
| NPCS0/NSS | Peripheral Chip Select/Slave Select | Output | Input |

18.6 Product Dependencies

18.6.1 I/O Lines

The pins used for interfacing the compliant external devices may be multiplexed with GPIO lines. The programmer must first program the GPIO controller to assign the SPI pins to their peripheral functions. To use the local loopback function the SPI pins must be controlled by the SPI.

18.6.2 Power Management

The SPI may be clocked through the Power Manager. Before using the SPI, the programmer must ensure that the SPI clock is enabled in the Power Manager.

In the SPI description, CLK_SPI is the clock of the peripheral bus to which the SPI is connected.

18.6.3 Interrupt

The SPI interface has an interrupt line connected to the Interrupt Controller (INTC). Handling the SPI interrupt requires programming the INTC before configuring the SPI.

18.7 Functional Description

18.7.1 Modes of Operation

The SPI operates in Master Mode or in Slave Mode.

Operation in Master Mode is programmed by writing at 1 the MSTR bit in the Mode Register. The pins NPCS0 to NPCS3 are all configured as outputs, the SPCK pin is driven, the MISO line is wired on the receiver input and the MOSI line driven as an output by the transmitter.

If the MSTR bit is written at 0, the SPI operates in Slave Mode. The MISO line is driven by the transmitter output, the MOSI line is wired on the receiver input, the SPCK pin is driven by the transmitter to synchronize the receiver. The NPCS0 pin becomes an input, and is used as a Slave Select signal (NSS). The pins NPCS1 to NPCS3 are not driven and can be used for other purposes.

The data transfers are identically programmable for both modes of operations. The baud rate generator is activated only in Master Mode.

18.7.2 Data Transfer

Four combinations of polarity and phase are available for data transfers. The clock polarity is programmed with the CPOL bit in the Chip Select Register. The clock phase is programmed with

the NCPHA bit. These two parameters determine the edges of the clock signal on which data is driven and sampled. Each of the two parameters has two possible states, resulting in four possible combinations that are incompatible with one another. Thus, a master/slave pair must use the same parameter pair values to communicate. If multiple slaves are used and fixed in different configurations, the master must reconfigure itself each time it needs to communicate with a different slave.

Table 18-2 shows the four modes and corresponding parameter settings.

Table 18-2. SPI modes

| SPI Mode | CPOL | NCPHA |
|----------|------|-------|
| 0 | 0 | 1 |
| 1 | 0 | 0 |
| 2 | 1 | 1 |
| 3 | 1 | 0 |

Figure 18-3 on page 197 and Figure 18-4 on page 197 show examples of data transfers.

Figure 18-3. SPI Transfer Format (NCPHA = 1, 8 bits per transfer)

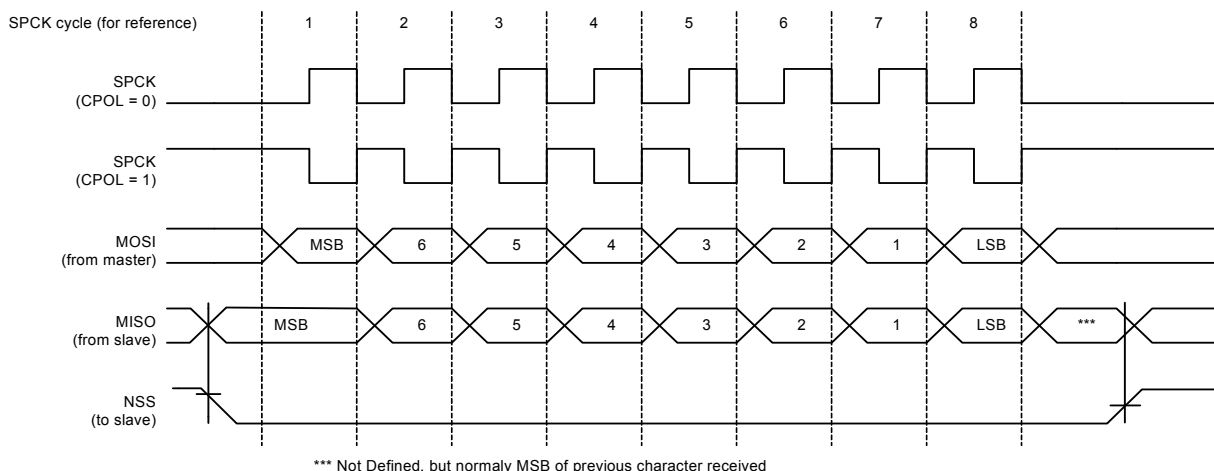
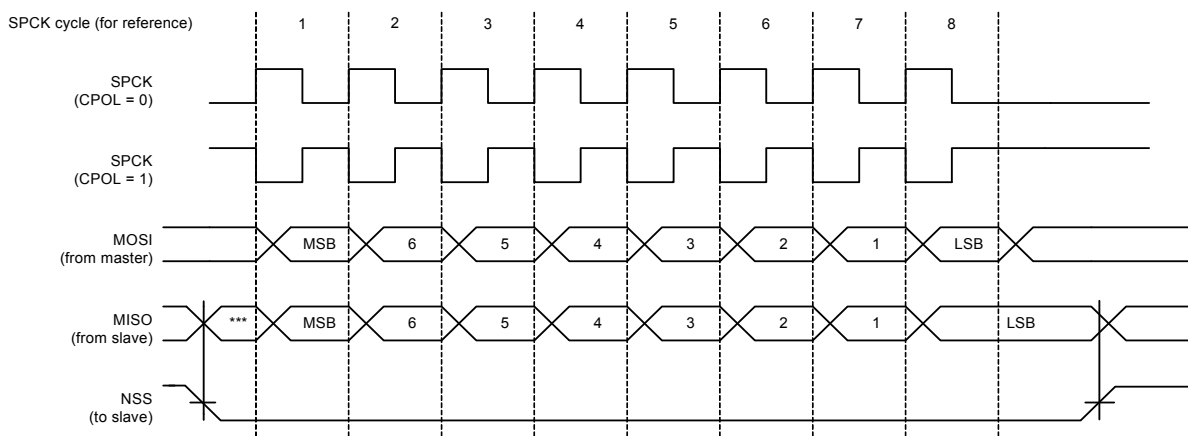

Figure 18-4. SPI Transfer Format (NCPHA = 0, 8 bits per transfer)



18.7.3 Master Mode Operations

When configured in Master Mode, the SPI uses the internal programmable baud rate generator as clock source. It fully controls the data transfers to and from the slave(s) connected to the SPI bus. The SPI drives the chip select line to the slave and the serial clock signal (SPCK).

The SPI features two holding registers, the Transmit Data Register and the Receive Data Register, and a single Shift Register. The holding registers maintain the data flow at a constant rate.

After enabling the SPI, a data transfer begins when the processor writes to the TDR (Transmit Data Register). The written data is immediately transferred in the Shift Register and transfer on the SPI bus starts. While the data in the Shift Register is shifted on the MOSI line, the MISO line is sampled and shifted in the Shift Register. Transmission cannot occur without reception.

Before writing the TDR, the PCS field must be set in order to select a slave.

If new data is written in TDR during the transfer, it stays in it until the current transfer is completed. Then, the received data is transferred from the Shift Register to RDR, the data in TDR is loaded in the Shift Register and a new transfer starts.

The transfer of a data written in TDR in the Shift Register is indicated by the TDRE bit (Transmit Data Register Empty) in the Status Register (SR). When new data is written in TDR, this bit is cleared. The TDRE bit is used to trigger the Transmit Peripheral DMA Controller channel.

The end of transfer is indicated by the TXEMPTY flag in the SR register. If a transfer delay (DLY-BCT) is greater than 0 for the last transfer, TXEMPTY is set after the completion of said delay. The CLK_SPI can be switched off at this time.

The transfer of received data from the Shift Register in RDR is indicated by the RDRF bit (Receive Data Register Full) in the Status Register (SR). When the received data is read, the RDRF bit is cleared.

If the RDR (Receive Data Register) has not been read before new data is received, the Overrun Error bit (OVRES) in SR is set. When this bit is set the SPI will continue to update RDR when data is received, overwriting the previously received data. The user has to read the status register to clear the OVRES bit.

[Figure 18-5 on page 199](#) shows a block diagram of the SPI when operating in Master Mode. [Figure 18-6 on page 200](#) shows a flow chart describing how transfers are handled.

18.7.3.1 Master Mode Block Diagram

Figure 18-5. Master Mode Block Diagram

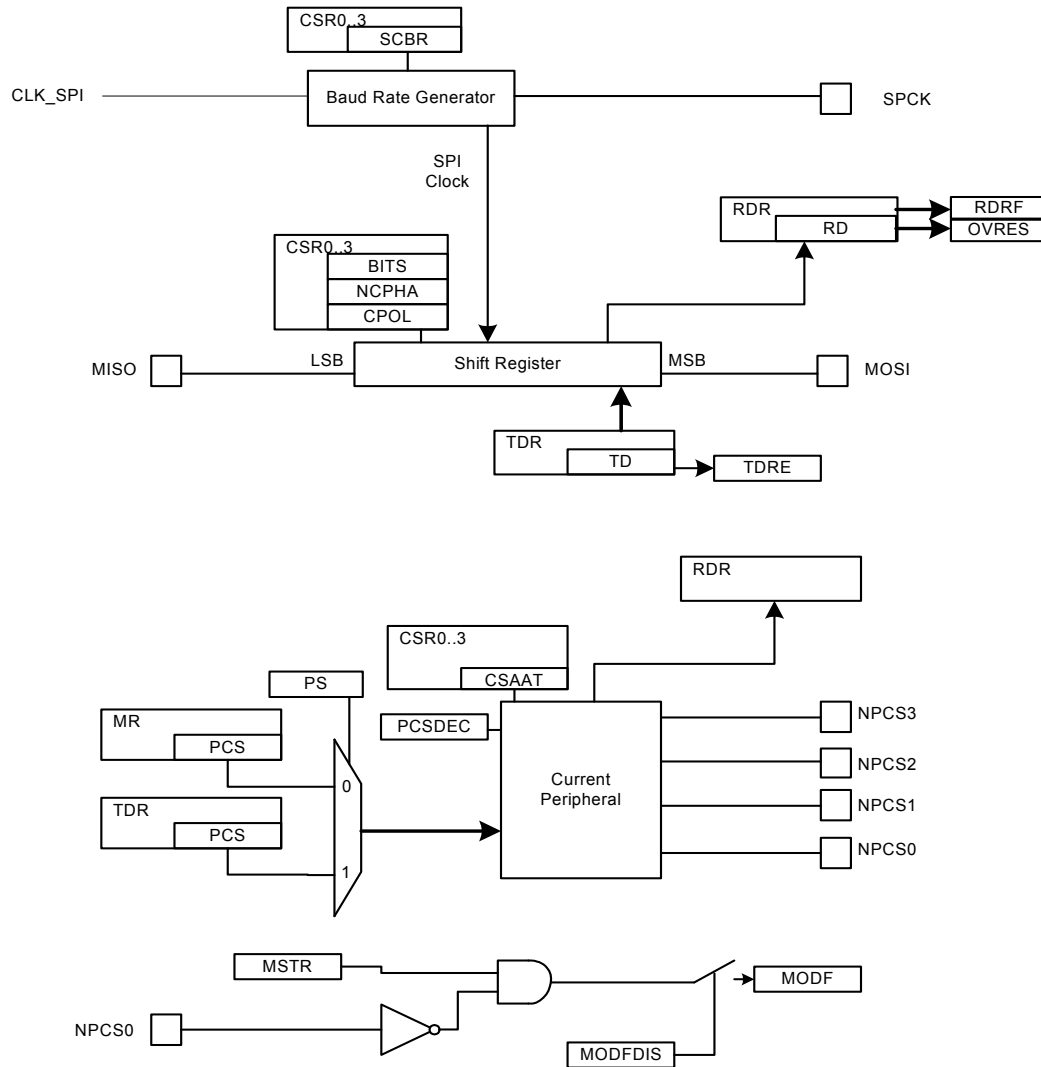

18.7.3.2 Master Mode Flow Diagram

Figure 18-6. Master Mode Flow Diagram

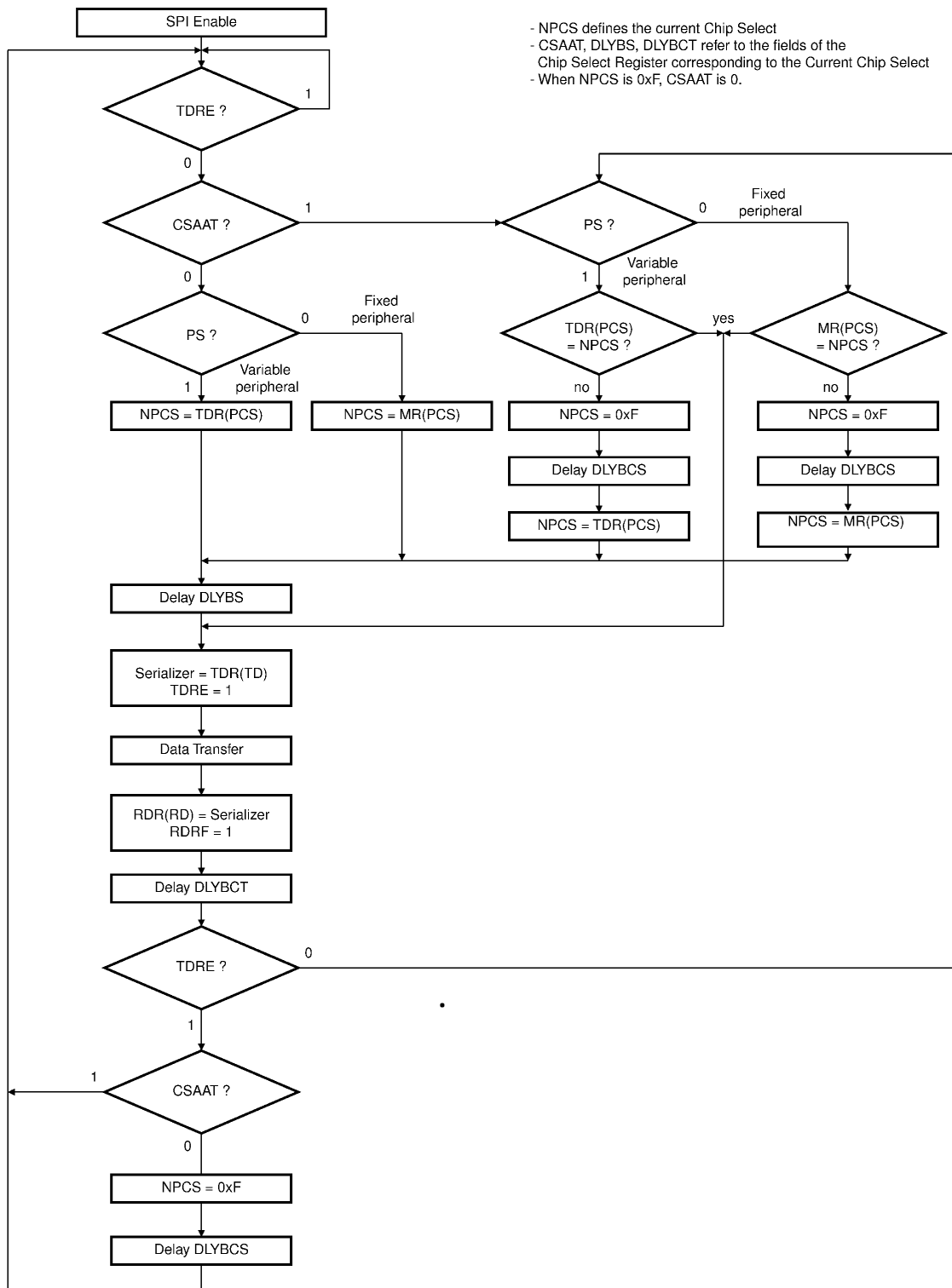

18.7.3.3 Clock Generation

The SPI Baud rate clock is generated by dividing the CLK_SPI by a value between 1 and 255.

This allows a maximum operating baud rate at up to CLK_SPI and a minimum operating baud rate of CLK_SPI divided by 255.

Programming the SCBR field at 0 is forbidden. Triggering a transfer while SCBR is at 0 can lead to unpredictable results.

At reset, SCBR is 0 and the user has to program it at a valid value before performing the first transfer.

The divisor can be defined independently for each chip select, as it has to be programmed in the SCBR field of the Chip Select Registers. This allows the SPI to automatically adapt the baud rate for each interfaced peripheral without reprogramming.

18.7.3.4 Transfer Delays

Figure 18-7 on page 201 shows a chip select transfer change and consecutive transfers on the same chip select. Three delays can be programmed to modify the transfer waveforms:

- The delay between chip selects, programmable only once for all the chip selects by writing the DLYBCS field in the Mode Register. Allows insertion of a delay between release of one chip select and before assertion of a new one.
- The delay before SPCK, independently programmable for each chip select by writing the field DLYBS. Allows the start of SPCK to be delayed after the chip select has been asserted.
- The delay between consecutive transfers, independently programmable for each chip select by writing the DLYBCT field. Allows insertion of a delay between two transfers occurring on the same chip select

These delays allow the SPI to be adapted to the interfaced peripherals and their speed and bus release time.

Figure 18-7. Programmable Delays

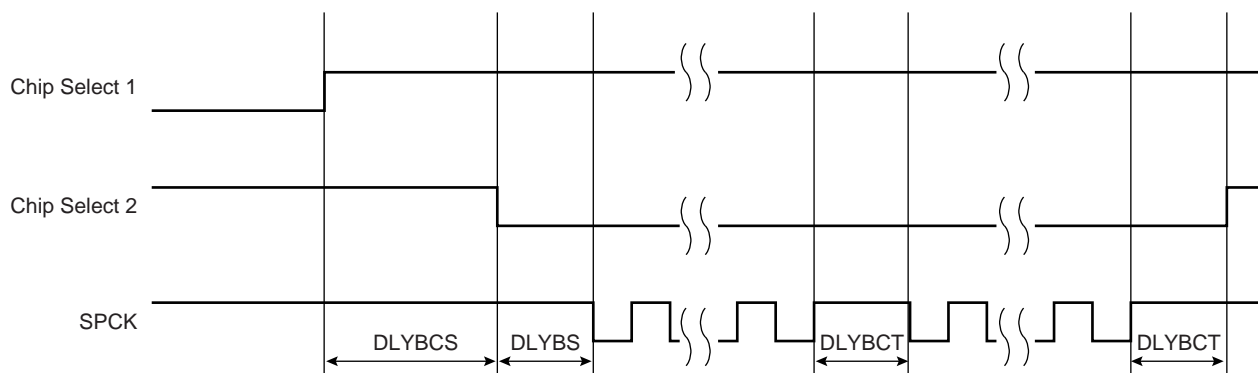

18.7.3.5 Peripheral Selection

The serial peripherals are selected through the assertion of the NPCS0 to NPCS3 signals. By default, all the NPCS signals are high before and after each transfer.

The peripheral selection can be performed in two different ways:

- Fixed Peripheral Select: SPI exchanges data with only one peripheral
- Variable Peripheral Select: Data can be exchanged with more than one peripheral

Fixed Peripheral Select is activated by writing the PS bit to zero in MR (Mode Register). In this case, the current peripheral is defined by the PCS field in MR and the PCS field in the TDR has no effect.

Variable Peripheral Select is activated by setting PS bit to one. The PCS field in TDR is used to select the current peripheral. This means that the peripheral selection can be defined for each new data.

The Fixed Peripheral Selection allows buffer transfers with a single peripheral. Using the Peripheral DMA Controller is an optimal means, as the size of the data transfer between the memory and the SPI is either 8 bits or 16 bits. However, changing the peripheral selection requires the Mode Register to be reprogrammed.

The Variable Peripheral Selection allows buffer transfers with multiple peripherals without reprogramming the Mode Register. Data written in TDR is 32 bits wide and defines the real data to be transmitted and the peripheral it is destined to. Using the Peripheral DMA Controller in this mode requires 32-bit wide buffers, with the data in the LSBs and the PCS and LASTXFER fields in the MSBs, however the SPI still controls the number of bits (8 to 16) to be transferred through MISO and MOSI lines with the chip select configuration registers. This is not the optimal means in terms of memory size for the buffers, but it provides a very effective means to exchange data with several peripherals without any intervention of the processor.

18.7.3.6 Peripheral Chip Select Decoding

The user can program the SPI to operate with up to 15 peripherals by decoding the four Chip Select lines, NPCS0 to NPCS3 with an external logic. This can be enabled by writing the PCS-DEC bit at 1 in the Mode Register (MR).

When operating without decoding, the SPI makes sure that in any case only one chip select line is activated, i.e. driven low at a time. If two bits are defined low in a PCS field, only the lowest numbered chip select is driven low.

When operating with decoding, the SPI directly outputs the value defined by the PCS field of either the Mode Register or the Transmit Data Register (depending on PS).

As the SPI sets a default value of 0xF on the chip select lines (i.e. all chip select lines at 1) when not processing any transfer, only 15 peripherals can be decoded.

The SPI has only four Chip Select Registers, not 15. As a result, when decoding is activated, each chip select defines the characteristics of up to four peripherals. As an example, CRS0 defines the characteristics of the externally decoded peripherals 0 to 3, corresponding to the PCS values 0x0 to 0x3. Thus, the user has to make sure to connect compatible peripherals on the decoded chip select lines 0 to 3, 4 to 7, 8 to 11 and 12 to 14.

18.7.3.7 Peripheral Deselection

When operating normally, as soon as the transfer of the last data written in TDR is completed, the NPCS lines all rise. This might lead to runtime error if the processor is too long in responding

to an interrupt, and thus might lead to difficulties for interfacing with some serial peripherals requiring the chip select line to remain active during a full set of transfers.

To facilitate interfacing with such devices, the Chip Select Register can be programmed with the CSAAT bit (Chip Select Active After Transfer) at 1. This allows the chip select lines to remain in their current state (low = active) until transfer to another peripheral is required.

Figure 18-8 on page 203 shows different peripheral deselection cases and the effect of the CSAAT bits.

Figure 18-8. Peripheral Deselection

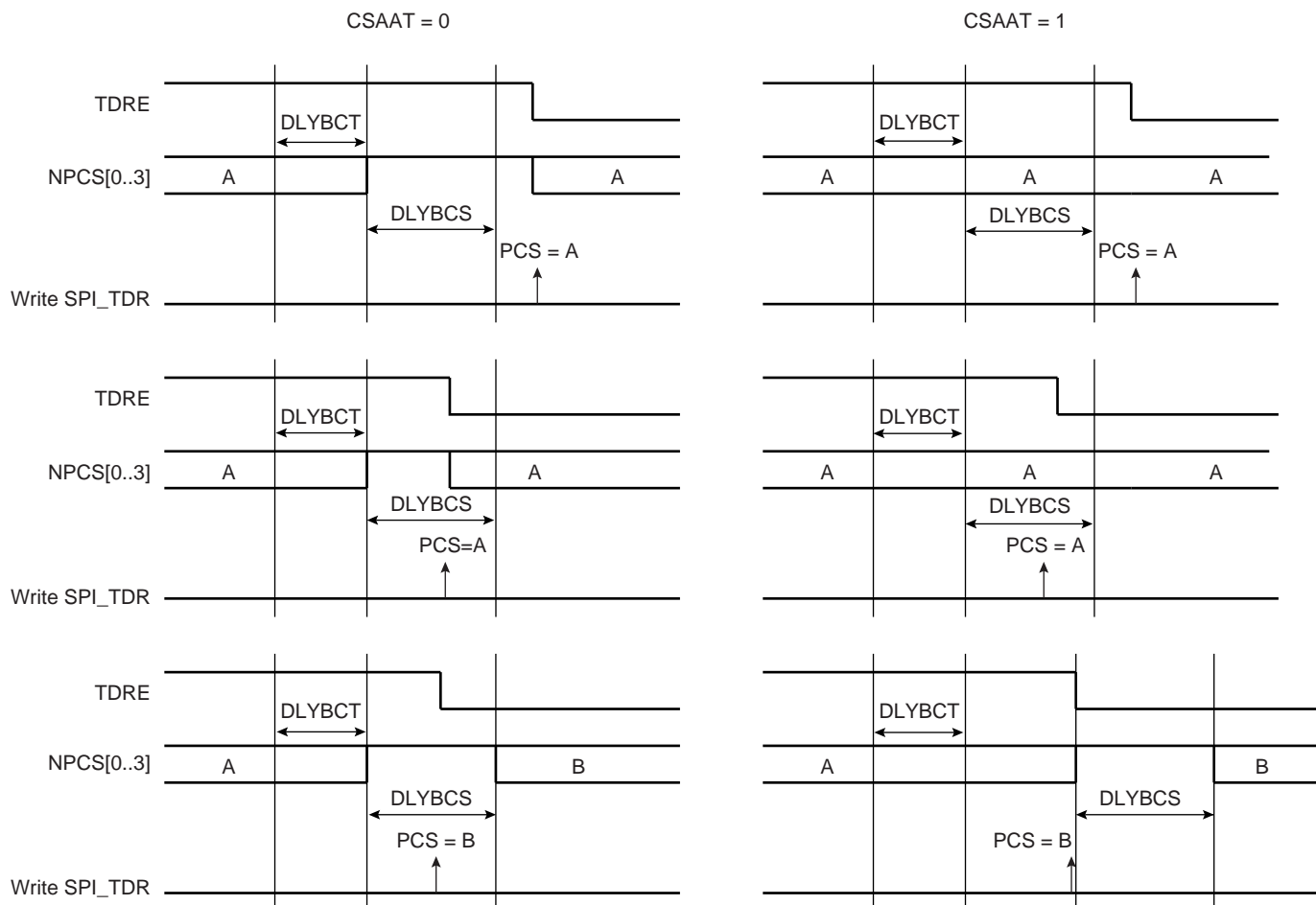

18.7.3.8 Mode Fault Detection

A mode fault is detected when the SPI is programmed in Master Mode and a low level is driven by an external master on the NPCS0/NSS signal. NPCS0, MOSI, MISO and SPCK must be configured in open drain through the GPIO controller, so that external pull up resistors are needed to guarantee high level.

When a mode fault is detected, the MODF bit in the SR is set until the SR is read and the SPI is automatically disabled until re-enabled by writing the SPIEN bit in the CR (Control Register) at 1.

By default, the Mode Fault detection circuitry is enabled. The user can disable Mode Fault detection by setting the MODFDIS bit in the SPI Mode Register (MR).

18.7.4 SPI Slave Mode

When operating in Slave Mode, the SPI processes data bits on the clock provided on the SPI clock pin (SPCK).

The SPI waits for NSS to go active before receiving the serial clock from an external master. When NSS falls, the clock is validated on the serializer, which processes the number of bits defined by the BITS field of the Chip Select Register 0 (CSR0). These bits are processed following a phase and a polarity defined respectively by the NCPHA and CPOL bits of the CSR0. Note that BITS, CPOL and NCPHA of the other Chip Select Registers have no effect when the SPI is programmed in Slave Mode.

The bits are shifted out on the MISO line and sampled on the MOSI line.

When all the bits are processed, the received data is transferred in the Receive Data Register and the RDRF bit rises. If the RDR (Receive Data Register) has not been read before new data is received, the Overrun Error bit (OVRES) in SR is set. Data is loaded in RDR even if this flag is set. The user has to read the status register to clear the OVRES bit.

When a transfer starts, the data shifted out is the data present in the Shift Register. If no data has been written in the Transmit Data Register (TDR), the last data received is transferred. If no data has been received since the last reset, all bits are transmitted low, as the Shift Register resets at 0.

When a first data is written in TDR, it is transferred immediately in the Shift Register and the TDRE bit rises. If new data is written, it remains in TDR until a transfer occurs, i.e. NSS falls and there is a valid clock on the SPCK pin. When the transfer occurs, the last data written in TDR is transferred in the Shift Register and the TDRE bit rises. This enables frequent updates of critical variables with single transfers.

Then, a new data is loaded in the Shift Register from the Transmit Data Register. In case no character is ready to be transmitted, i.e. no character has been written in TDR since the last load from TDR to the Shift Register, the Shift Register is not modified and the last received character is retransmitted.

[Figure 18-9 on page 205](#) shows a block diagram of the SPI when operating in Slave Mode.

Figure 18-9. Slave Mode Functional Block Diagram

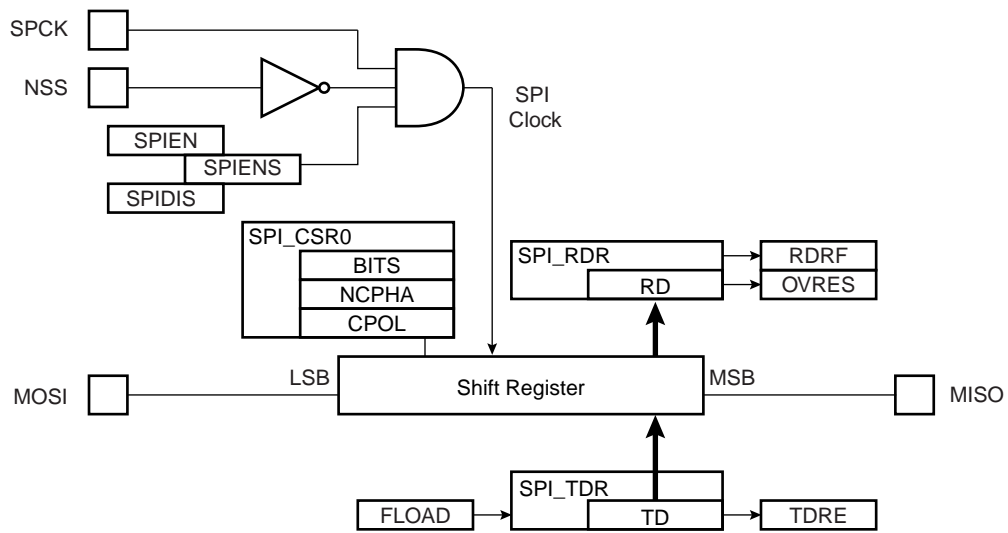

18.8 User Interface

Table 18-3. SPI Register Memory Map

| Offset | Register | Name | Access | Reset |
|--------|----------------------------|---------|------------|--------------------|
| 0x00 | Control Register | CR | Write-only | 0x00000000 |
| 0x04 | Mode Register | MR | Read/write | 0x00000000 |
| 0x08 | Receive Data Register | RDR | Read-only | 0x00000000 |
| 0x0C | Transmit Data Register | TDR | Write-only | 0x00000000 |
| 0x10 | Status Register | SR | Read-only | 0x000000F0 |
| 0x14 | Interrupt Enable Register | IER | Write-only | 0x00000000 |
| 0x18 | Interrupt Disable Register | IDR | Write-only | 0x00000000 |
| 0x1C | Interrupt Mask Register | IMR | Read-only | 0x00000000 |
| 0x30 | Chip Select Register 0 | CSR0 | Read/write | 0x00000000 |
| 0x34 | Chip Select Register 1 | CSR1 | Read/write | 0x00000000 |
| 0x38 | Chip Select Register 2 | CSR2 | Read/write | 0x00000000 |
| 0x3C | Chip Select Register 3 | CSR3 | Read/write | 0x00000000 |
| 0x00FC | Version Register | VERSION | Read-only | 0x- ⁽¹⁾ |

Note: 1. Values in the Version Register vary with the version of the IP block implementation.

18.8.1 Control Register

Name: CR
Access Type: Write-only
Offset: 0x00
Reset Value: 0x00000000

| | | | | | | | |
|-------|----|----|----|----|----|--------|----------|
| 31 | 30 | 29 | 28 | 27 | 26 | 25 | 24 |
| – | – | – | – | – | – | – | LASTXFER |
| 23 | 22 | 21 | 20 | 19 | 18 | 17 | 16 |
| – | – | – | – | – | – | – | – |
| 15 | 14 | 13 | 12 | 11 | 10 | 9 | 8 |
| – | – | – | – | – | – | – | – |
| 7 | 6 | 5 | 4 | 3 | 2 | 1 | 0 |
| SWRST | – | – | – | – | – | SPIDIS | SPIEN |

- **LASTXFER: Last Transfer**

0: No effect.

1: The current NPCS will be deasserted after the character written in TD has been transferred. When CSAAT is set, this allows to close the communication with the current serial peripheral by raising the corresponding NPCS line as soon as TD transfer has completed.

- **SWRST: SPI Software Reset**

0: No effect.

1: Reset the SPI. A software-triggered hardware reset of the SPI interface is performed.

The SPI is in slave mode after software reset.

Peripheral DMA Controller channels are not affected by software reset.

- **SPIDIS: SPI Disable**

0: No effect.

1: Disables the SPI.

As soon as SPIDIS is set, SPI finishes its transfer.

All pins are set in input mode and no data is received or transmitted.

If a transfer is in progress, the transfer is finished before the SPI is disabled.

If both SPIEN and SPIDIS are equal to one when the control register is written, the SPI is disabled.

- **SPIEN: SPI Enable**

0: No effect.

1: Enables the SPI to transfer and receive data.

18.8.2 Mode Register

Name: MR
Access Type: Read/Write
Offset: 0x04
Reset Value: 0x00000000

| | | | | | | | |
|--------|----|----|---------|-----|--------|----|------|
| 31 | 30 | 29 | 28 | 27 | 26 | 25 | 24 |
| DLYBCS | | | | | | | |
| 23 | 22 | 21 | 20 | 19 | 18 | 17 | 16 |
| - | - | - | - | PCS | | | |
| 15 | 14 | 13 | 12 | 11 | 10 | 9 | 8 |
| - | - | - | - | - | - | - | - |
| 7 | 6 | 5 | 4 | 3 | 2 | 1 | 0 |
| LLB | - | - | MODFDIS | - | PCSDEC | PS | MSTR |

- **DLYBCS: Delay Between Chip Selects**

This field defines the delay from NPCS inactive to the activation of another NPCS. The DLYBCS time guarantees non-overlapping chip selects and solves bus contentions in case of peripherals having long data float times.

If DLYBCS is less than or equal to six, six CLK_SPI periods will be inserted by default.

Otherwise, the following equation determines the delay:

$$\text{Delay Between Chip Selects} = \frac{DLYBCS}{CLKSPI}$$

- **PCS: Peripheral Chip Select**

This field is only used if Fixed Peripheral Select is active (PS = 0).

If PCSDEC = 0:

PCS = xxx0NPCS[3:0] = 1110

PCS = xx01NPCS[3:0] = 1101

PCS = x011NPCS[3:0] = 1011

PCS = 0111NPCS[3:0] = 0111

PCS = 1111forbidden (no peripheral is selected)

(x = don't care)

If PCSDEC = 1:

NPCS[3:0] output signals = PCS.

- **LLB: Local Loopback Enable**

0: Local loopback path disabled.

1: Local loopback path enabled (

LLB controls the local loopback on the data serializer for testing in Master Mode only. (MISO is internally connected on MOSI.)

- **MODFDIS: Mode Fault Detection**

0: Mode fault detection is enabled.

1: Mode fault detection is disabled.

- **PCSDEC: Chip Select Decode**

0: The chip selects are directly connected to a peripheral device.

1: The four chip select lines are connected to a 4- to 16-bit decoder.

When PCSDEC equals one, up to 15 Chip Select signals can be generated with the four lines using an external 4- to 16-bit decoder. The Chip Select Registers define the characteristics of the 15 chip selects according to the following rules:

CSR0 defines peripheral chip select signals 0 to 3.

CSR1 defines peripheral chip select signals 4 to 7.

CSR2 defines peripheral chip select signals 8 to 11.



CSR3 defines peripheral chip select signals 12 to 14.

- **PS: Peripheral Select**
 - 0: Fixed Peripheral Select.
 - 1: Variable Peripheral Select.
- **MSTR: Master/Slave Mode**
 - 0: SPI is in Slave mode.
 - 1: SPI is in Master mode.

18.8.3 Receive Data Register

Name: RDR

Access Type: Read-only

Offset: 0x08

Reset Value: 0x00000000

| | | | | | | | |
|----|----|----|----|----|----|----|----|
| 31 | 30 | 29 | 28 | 27 | 26 | 25 | 24 |
| - | - | - | - | - | - | - | - |
| 23 | 22 | 21 | 20 | 19 | 18 | 17 | 16 |
| - | - | - | - | - | - | - | - |
| 15 | 14 | 13 | 12 | 11 | 10 | 9 | 8 |
| RD | | | | | | | |
| 7 | 6 | 5 | 4 | 3 | 2 | 1 | 0 |
| RD | | | | | | | |

- **RD: Receive Data**

Data received by the SPI Interface is stored in this register right-justified. Unused bits read zero.

18.8.4 Transmit Data Register

Name: TDR
Access Type: Write-only
Offset: 0x0C
Reset Value: 0x00000000

| | | | | | | | |
|----|----|----|----|-----|----|----|----------|
| 31 | 30 | 29 | 28 | 27 | 26 | 25 | 24 |
| – | – | – | – | – | – | – | LASTXFER |
| 23 | 22 | 21 | 20 | 19 | 18 | 17 | 16 |
| – | – | – | – | PCS | | | |
| 15 | 14 | 13 | 12 | 11 | 10 | 9 | 8 |
| TD | | | | | | | |
| 7 | 6 | 5 | 4 | 3 | 2 | 1 | 0 |
| TD | | | | | | | |

- **LASTXFER: Last Transfer**

0: No effect.

1: The current NPCS will be deasserted after the character written in TD has been transferred. When CSAAT is set, this allows to close the communication with the current serial peripheral by raising the corresponding NPCS line as soon as TD transfer has completed.

This field is only used if Variable Peripheral Select is active (PS = 1).

- **PCS: Peripheral Chip Select**

This field is only used if Variable Peripheral Select is active (PS = 1).

If PCSDEC = 0:

PCS = xx0NPCS[3:0] = 1110

PCS = xx01NPCS[3:0] = 1101

PCS = x011NPCS[3:0] = 1011

PCS = 0111NPCS[3:0] = 0111

PCS = 1111 forbidden (no peripheral is selected)

(x = don't care)

If PCSDEC = 1:

NPCS[3:0] output signals = PCS

- **TD: Transmit Data**

Data to be transmitted by the SPI Interface is stored in this register. Information to be transmitted must be written to the transmit data register in a right-justified format.

18.8.5 Status Register

Name: SR
Access Type: Read-only
Offset: 0x10
Reset Value: 0x00000000

| | | | | | | | |
|----|----|----|----|-------|------|---------|--------|
| 31 | 30 | 29 | 28 | 27 | 26 | 25 | 24 |
| – | – | – | – | – | – | – | – |
| 23 | 22 | 21 | 20 | 19 | 18 | 17 | 16 |
| – | – | – | – | – | – | – | SPIENS |
| 15 | 14 | 13 | 12 | 11 | 10 | 9 | 8 |
| – | – | – | – | – | – | TXEMPTY | NSSR |
| 7 | 6 | 5 | 4 | 3 | 2 | 1 | 0 |
| – | – | – | – | OVRES | MODF | TDRE | RDRF |

- **SPIENS: SPI Enable Status**
 - 0: SPI is disabled.
 - 1: SPI is enabled.
- **TXEMPTY: Transmission Registers Empty**
 - 0: As soon as data is written in TDR.
 - 1: TDR and internal shifter are empty. If a transfer delay has been defined, TXEMPTY is set after the completion of such delay.
- **NSSR: NSS Rising**
 - 0: No rising edge detected on NSS pin since last read.
 - 1: A rising edge occurred on NSS pin since last read.
- **OVRES: Overrun Error Status**
 - 0: No overrun has been detected since the last read of SR.
 - 1: An overrun has occurred since the last read of SR.
An overrun occurs when RDR is loaded at least twice from the serializer since the last read of the RDR.
- **MODF: Mode Fault Error**
 - 0: No Mode Fault has been detected since the last read of SR.
 - 1: A Mode Fault occurred since the last read of the SR.
- **TDRE: Transmit Data Register Empty**
 - 0: Data has been written to TDR and not yet transferred to the serializer.
 - 1: The last data written in the Transmit Data Register has been transferred to the serializer.
TDRE equals zero when the SPI is disabled or at reset. The SPI enable command sets this bit to one.
- **RDRF: Receive Data Register Full**
 - 0: No data has been received since the last read of RDR
 - 1: Data has been received and the received data has been transferred from the serializer to RDR since the last read of RDR.

18.8.6 Interrupt Enable Register

Name: IER
Access Type: Write-only
Offset: 0x14
Reset Value: 0x00000000

| | | | | | | | |
|----|----|----|----|-------|------|---------|------|
| 31 | 30 | 29 | 28 | 27 | 26 | 25 | 24 |
| – | – | – | – | – | – | – | – |
| 23 | 22 | 21 | 20 | 19 | 18 | 17 | 16 |
| – | – | – | – | – | – | – | – |
| 15 | 14 | 13 | 12 | 11 | 10 | 9 | 8 |
| – | – | – | – | – | – | TXEMPTY | NSSR |
| 7 | 6 | 5 | 4 | 3 | 2 | 1 | 0 |
| – | – | – | – | OVRES | MODF | TDRE | RDRF |

Writing a zero to a bit in this register has no effect.

Writing a one to a bit in this register will set the corresponding bit in IMR.

18.8.7 Interrupt Disable Register

Name: IDR
Access Type: Write-only
Offset: 0x18
Reset Value: 0x00000000

| | | | | | | | |
|----|----|----|----|-------|------|---------|------|
| 31 | 30 | 29 | 28 | 27 | 26 | 25 | 24 |
| – | – | – | – | – | – | – | – |
| 23 | 22 | 21 | 20 | 19 | 18 | 17 | 16 |
| – | – | – | – | – | – | – | – |
| 15 | 14 | 13 | 12 | 11 | 10 | 9 | 8 |
| – | – | – | – | – | – | TXEMPTY | NSSR |
| 7 | 6 | 5 | 4 | 3 | 2 | 1 | 0 |
| – | – | – | – | OVRES | MODF | TDRE | RDRF |

Writing a zero to a bit in this register has no effect.

Writing a one to a bit in this register will clear the corresponding bit in IMR.

18.8.8 Interrupt Mask Register

Name: IMR

Access Type: Read-only

Offset: 0x1C

Reset Value: 0x00000000

| | | | | | | | |
|----|----|----|----|-------|------|---------|------|
| 31 | 30 | 29 | 28 | 27 | 26 | 25 | 24 |
| – | – | – | – | – | – | – | – |
| 23 | 22 | 21 | 20 | 19 | 18 | 17 | 16 |
| – | – | – | – | – | – | – | – |
| 15 | 14 | 13 | 12 | 11 | 10 | 9 | 8 |
| – | – | – | – | – | – | TXEMPTY | NSSR |
| 7 | 6 | 5 | 4 | 3 | 2 | 1 | 0 |
| – | – | – | – | OVRES | MODF | TDRE | RDRF |

0: The corresponding interrupt is disabled.

1: The corresponding interrupt is enabled.

A bit in this register is cleared when the corresponding bit in IDR is written to one.

A bit in this register is set when the corresponding bit in IER is written to one.

18.8.9 Chip Select Register n

Name: CSRn
Access Type: Read/Write
Offset: 0x30 +0x04*n
Reset Value: 0x00000000

| | | | | | | | |
|--------|----|----|----|-------|--------|-------|------|
| 31 | 30 | 29 | 28 | 27 | 26 | 25 | 24 |
| DLYBCT | | | | | | | |
| 23 | 22 | 21 | 20 | 19 | 18 | 17 | 16 |
| DLYBS | | | | | | | |
| 15 | 14 | 13 | 12 | 11 | 10 | 9 | 8 |
| SCBR | | | | | | | |
| 7 | 6 | 5 | 4 | 3 | 2 | 1 | 0 |
| BITS | | | | CSAAT | CSNAAT | NCPHA | CPOL |

- DLYBCT: Delay Between Consecutive Transfers**

This field defines the delay between two consecutive transfers with the same peripheral without removing the chip select. The delay is always inserted after each transfer and before removing the chip select if needed.

When DLYBCT equals zero, no delay between consecutive transfers is inserted and the clock keeps its duty cycle over the character transfers.

Otherwise, the following equation determines the delay:

$$\text{Delay Between Consecutive Transfers} = \frac{32 \times DLYBCT}{CLKSPI}$$

- DLYBS: Delay Before SPCK**

This field defines the delay from NPCS valid to the first valid SPCK transition.

When DLYBS equals zero, the NPCS valid to SPCK transition is 1/2 the SPCK clock period.

Otherwise, the following equations determine the delay:

$$\text{Delay Before SPCK} = \frac{DLYBS}{CLKSPI}$$

- ISCBR: Serial Clock Baud Rate**

In Master Mode, the SPI Interface uses a modulus counter to derive the SPCK baud rate from the CLK_SPI. The Baud rate is selected by writing a value from 1 to 255 in the SCBR field. The following equations determine the SPCK baud rate:

$$\text{SPCK Baudrate} = \frac{CLKSPI}{SCBR}$$

Writing 0 to the SCBR field is forbidden. Triggering a transfer while SCBR is 0 can lead to unpredictable results.

At reset, SCBR is 0 and the user has to write it at a valid value before performing the first transfer.

If a clock divider (SCBRn) is set to 1 and the other SCBR differ from 1, access on CSn is correct but no correct access will be possible on others CS.

- **BITS: Bits Per Transfer**

The BITS field determines the number of data bits transferred. Reserved values should not be used.

| BITS | Bits Per Transfer |
|------|-------------------|
| 0000 | 8 |
| 0001 | 9 |
| 0010 | 10 |
| 0011 | 11 |
| 0100 | 12 |
| 0101 | 13 |
| 0110 | 14 |
| 0111 | 15 |
| 1000 | 16 |
| 1001 | Reserved |
| 1010 | Reserved |
| 1011 | Reserved |
| 1100 | Reserved |
| 1101 | Reserved |
| 1110 | Reserved |
| 1111 | Reserved |

- **CSAAT: Chip Select Active After Transfer**

0: The Peripheral Chip Select Line rises as soon as the last transfer is achieved.

1: The Peripheral Chip Select does not rise after the last transfer is achieved. It remains active until a new transfer is requested on a different chip select.

- **CSNAAT: Chip Select Not Active After Transfer**

0 = The Peripheral Chip Select Line rises as soon as the last transfer is achieved

1 = The Peripheral Chip Select Line rises after every transfer

CSNAAT can be used to force the Peripheral Chip Select Line to go inactive after every transfer. This allows successful interfacing to SPI slave devices that require this behavior.

- **NCPHA: Clock Phase**

0: Data is changed on the leading edge of SPCK and captured on the following edge of SPCK.

1: Data is captured on the leading edge of SPCK and changed on the following edge of SPCK.

NCPHA determines which edge of SPCK causes data to change and which edge causes data to be captured. NCPHA is used with CPOL to produce the required clock/data relationship between master and slave devices.

- **CPOL: Clock Polarity**

0: The inactive state value of SPCK is logic level zero.

1: The inactive state value of SPCK is logic level one.

CPOL is used to determine the inactive state value of the serial clock (SPCK). It is used with NCPHA to produce the required clock/data relationship between master and slave devices.

19. Two-Wire Interface (TWI)

2.1.1.1

19.1 Features

- **Compatible with Atmel Two-wire Interface Serial Memory and I²C Compatible Devices⁽¹⁾**
- **One, Two or Three Bytes for Slave Address**
- **Sequential Read-write Operations**
- **Master, Multi-master and Slave Mode Operation**
- **Bit Rate: Up to 400 Kbits**
- **General Call Supported in Slave mode**
- **Connection to Peripheral DMA Controller Channel Capabilities Optimizes Data Transfers in Master Mode Only**
 - **One Channel for the Receiver, One Channel for the Transmitter**
 - **Next Buffer Support**

Note: 1. See [Table 19-1](#) below for details on compatibility with I²C Standard.

19.2 Overview

The Atmel Two-wire Interface (TWI) interconnects components on a unique two-wire bus, made up of one clock line and one data line with speeds of up to 400 Kbits per second, based on a byte-oriented transfer format. It can be used with any Atmel Two-wire Interface bus Serial EEPROM and I²C compatible device such as Real Time Clock (RTC), Dot Matrix/Graphic LCD Controllers and Temperature Sensor, to name but a few. The TWI is programmable as a master or a slave with sequential or single-byte access. Multiple master capability is supported. Arbitration of the bus is performed internally and puts the TWI in slave mode automatically if the bus arbitration is lost.

A configurable baud rate generator permits the output data rate to be adapted to a wide range of core clock frequencies.

Below, [Table 19-1](#) lists the compatibility level of the Atmel Two-wire Interface in Master Mode and a full I²C compatible device.

Table 19-1. Atmel TWI compatibility with I²C Standard

| I ² C Standard | Atmel TWI |
|---|---------------|
| Standard Mode Speed (100 KHz) | Supported |
| Fast Mode Speed (400 KHz) | Supported |
| 7 or 10 bits Slave Addressing | Supported |
| START BYTE ⁽¹⁾ | Not Supported |
| Repeated Start (Sr) Condition | Supported |
| ACK and NACK Management | Supported |
| Slope control and input filtering (Fast mode) | Not Supported |
| Clock stretching | Supported |

Note: 1. START + b000000001 + Ack + Sr

19.3 List of Abbreviations

Table 19-2. Abbreviations

| Abbreviation | Description |
|--------------|-------------------------|
| TWI | Two-wire Interface |
| A | Acknowledge |
| NA | Non Acknowledge |
| P | Stop |
| S | Start |
| Sr | Repeated Start |
| SADR | Slave Address |
| ADR | Any address except SADR |
| R | Read |
| W | Write |

19.4 Block Diagram

Figure 19-1. Block Diagram

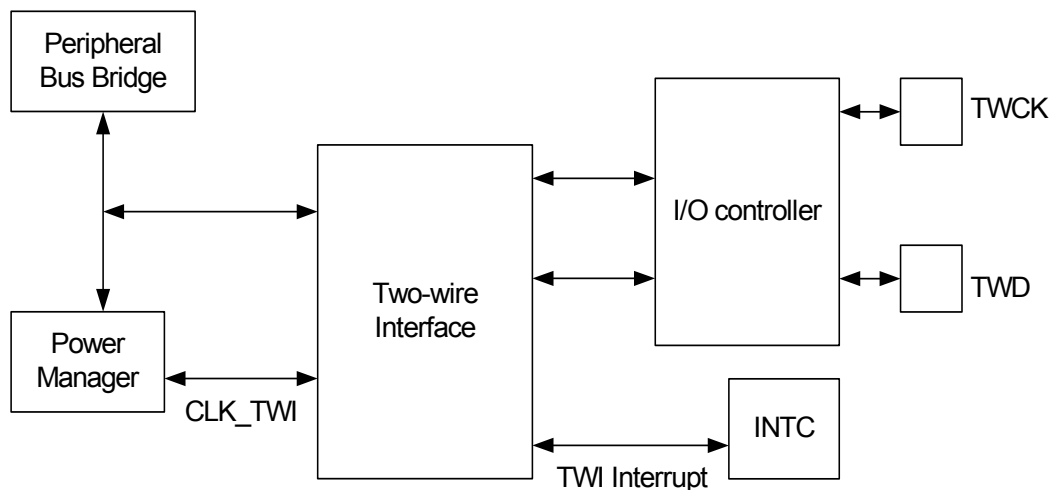

19.5 Application Block Diagram

Figure 19-2. Application Block Diagram

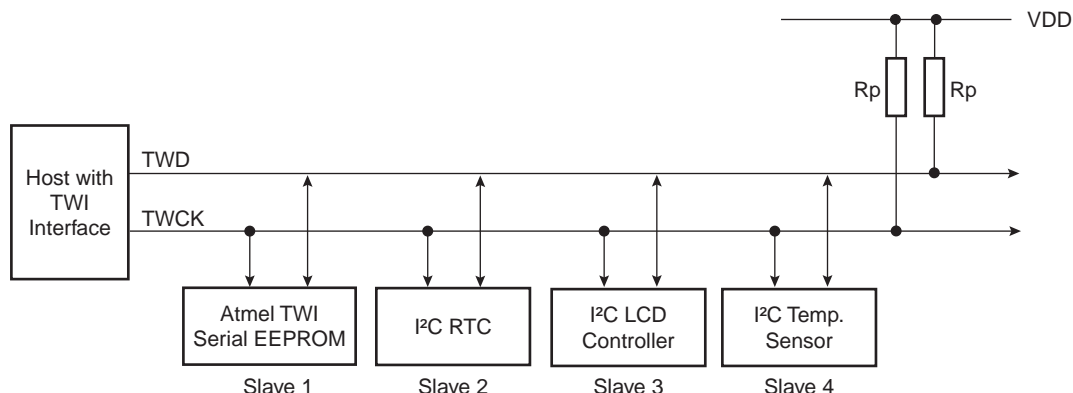

Rp: Pull up value as given by the I2C Standard

19.6 I/O Lines Description

Table 19-3. I/O Lines Description

| Pin Name | Pin Description | Type |
|----------|-----------------------|--------------|
| TWD | Two-wire Serial Data | Input/Output |
| TWCK | Two-wire Serial Clock | Input/Output |

19.7 Product Dependencies

19.7.1 I/O Lines

Both TWD and TWCK are bidirectional lines, connected to a positive supply voltage via a current source or pull-up resistor (see [Figure 19-2 on page 220](#)). When the bus is free, both lines are high. The output stages of devices connected to the bus must have an open-drain or open-collector to perform the wired-AND function.

TWD and TWCK pins may be multiplexed with GPIO lines. To enable the TWI, the programmer must perform the following steps:

- Program the GPIO controller to:
 - Dedicate TWD and TWCK as peripheral lines.
 - Define TWD and TWCK as open-drain.

19.7.2 Power Management

The TWI clock is generated by the Power Manager (PM). Before using the TWI, the programmer must ensure that the TWI clock is enabled in the PM.

In the TWI description, Master Clock (CLK_TWI) is the clock of the peripheral bus to which the TWI is connected.

19.7.3 Interrupt

The TWI interface has an interrupt line connected to the Interrupt Controller (INTC). In order to handle interrupts, the INTC must be programmed before configuring the TWI.

19.8 Functional Description

19.8.1 Transfer Format

The data put on the TWD line must be 8 bits long. Data is transferred MSB first; each byte must be followed by an acknowledgement. The number of bytes per transfer is unlimited (see [Figure 19-4](#)).

Each transfer begins with a START condition and terminates with a STOP condition (see [Figure 19-3](#)).

- A high-to-low transition on the TWD line while TWCK is high defines the START condition.
- A low-to-high transition on the TWD line while TWCK is high defines a STOP condition.

Figure 19-3. START and STOP Conditions

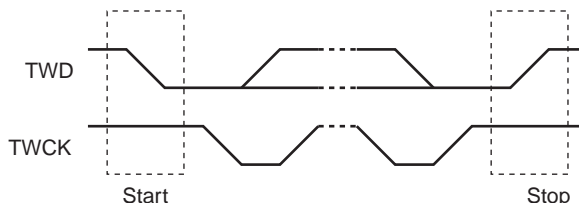
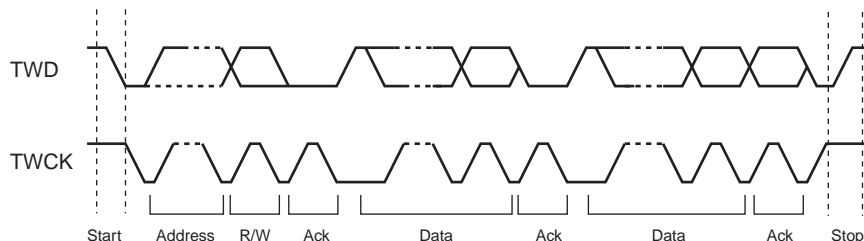

Figure 19-4. Transfer Format



19.9 Modes of Operation

The TWI has six modes of operations:

- Master transmitter mode
- Master receiver mode
- Multi-master transmitter mode
- Multi-master receiver mode
- Slave transmitter mode
- Slave receiver mode

These modes are described in the following chapters.

19.10 Master Mode

19.10.1 Definition

The Master is the device which starts a transfer, generates a clock and stops it.

19.10.2 Application Block Diagram

Figure 19-5. Master Mode Typical Application Block Diagram

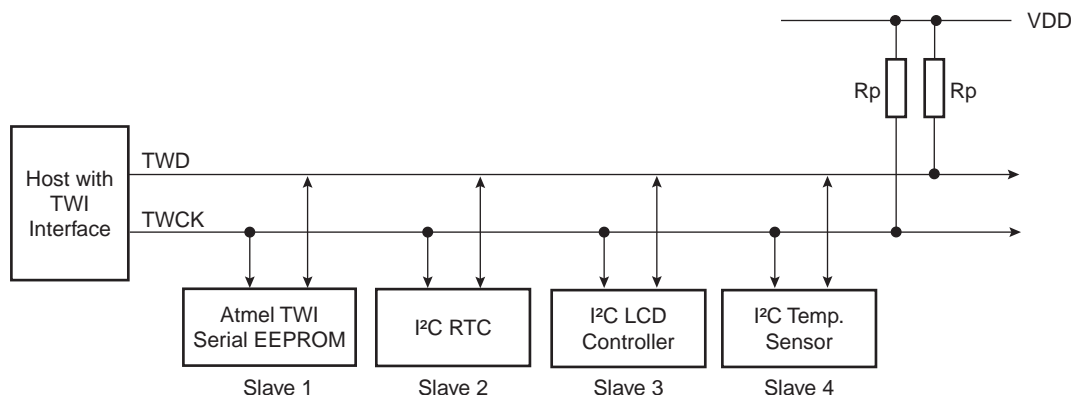

Rp: Pull up value as given by the I²C Standard

19.10.3 Programming Master Mode

The following registers have to be programmed before entering Master mode:

1. DADR (+ IADRSZ + IADR if a 10 bit device is addressed): The device address is used to access slave devices in read or write mode.
2. CKDIV + CHDIV + CLDIV: Determines clock waveform T_{high} and T_{low} .
3. SVDIS: Disable the slave mode.
4. MSEN: Enable the master mode.

19.10.4 Master Mode Clock Timing

The TWI module monitors the state of the TWCK line as required by the I²C specification. The counter that determines the TWCK T_{high} or T_{low} duration is started whenever a high or low level is detected by the module on TWCK, not when the module begins releasing or driving the TWCK line. Thus, the CWGR.CHDIV and CLDIV fields do not alone determine the overall TWCK period; they merely determine the T_{high} and T_{low} components, whereas the rise and fall times (T_{rise} and T_{fall}) are determined by the external circuitry on the TWCK pin as well as the propagation and synchronization delay of TWCK from the pin back into the TWI module. The TWI module does not attempt to compensate for these delays, so the overall TWI clock period is given by $T_{high} + T_{fall} + T_{low} + T_{rise}$.

19.10.5 Master Transmitter Mode

After the master initiates a Start condition when writing into the Transmit Holding Register, THR, it sends a 7-bit slave address, configured in the Master Mode register (DADR in MMR), to notify the slave device. The bit following the slave address indicates the transfer direction, 0 in this case (MREAD = 0 in MMR).

The TWI transfers require the slave to acknowledge each received byte. During the acknowledge clock pulse (9th pulse), the master releases the data line (HIGH), enabling the slave to pull it down in order to generate the acknowledge. The master polls the data line during this clock pulse and sets the NACK in the status register if the slave does not acknowledge the byte. As with the other status bits, an interrupt can be generated if enabled in the interrupt enable register (IER). If the slave acknowledges the byte, the data written in the THR, is then shifted in the internal shifter and transferred. When an acknowledge is detected, the TXRDY bit is set until a new write in the THR. When no more data is written into the THR, the master generates a stop condition to end the transfer. The end of the complete transfer is marked by the TXCOMP bit set to one. See [Figure 19-6](#), [Figure 19-7](#), and [Figure 19-8](#) on page 223.

TXRDY is used as Transmit Ready for the Peripheral DMA Controller transmit channel.

Figure 19-6. Master Write with One Data Byte

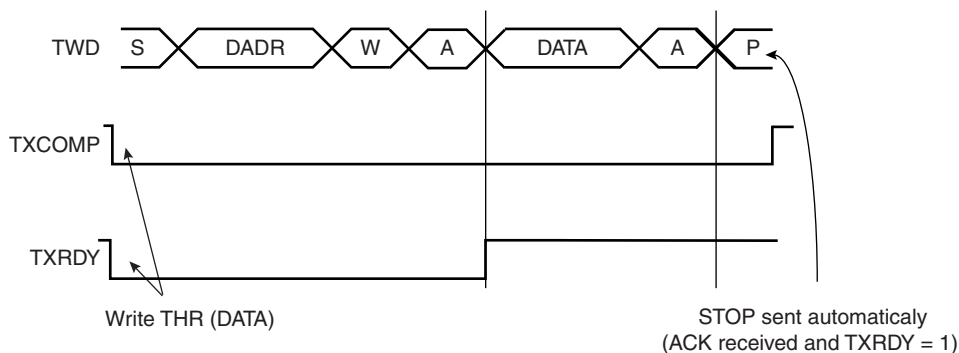

Figure 19-7. Master Write with Multiple Data Byte

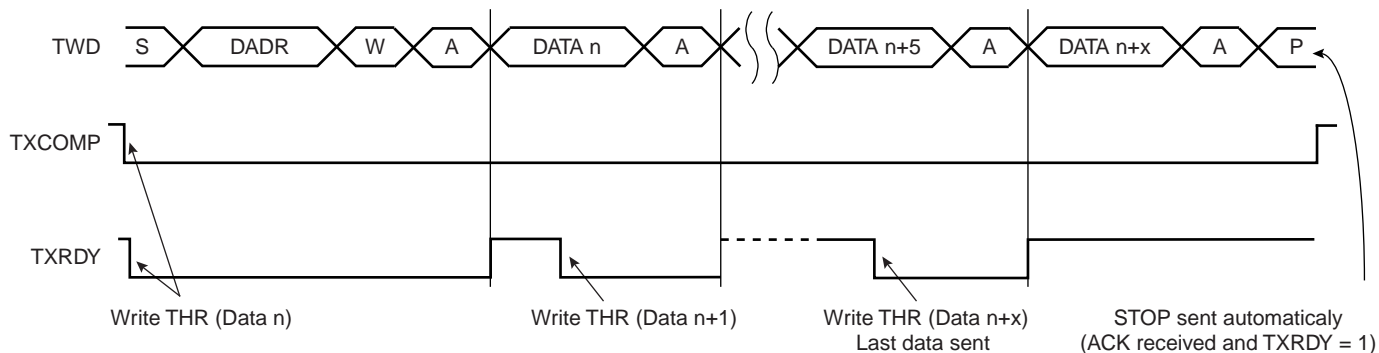
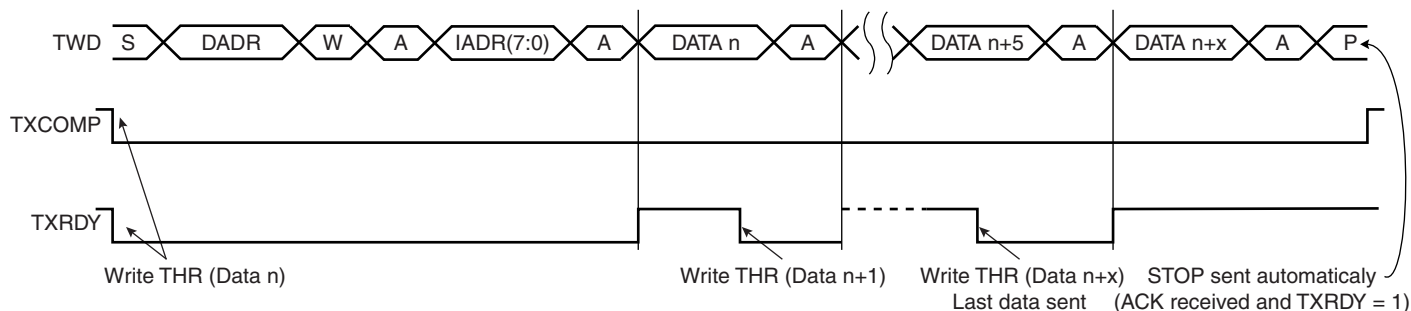

Figure 19-8. Master Write with One Byte Internal Address and Multiple Data Bytes



19.10.6 Master Receiver Mode

The read sequence begins by setting the START bit. After the start condition has been sent, the master sends a 7-bit slave address to notify the slave device. The bit following the slave address indicates the transfer direction, 1 in this case (MREAD = 1 in MMR). During the acknowledge clock pulse (9th pulse), the master releases the data line (HIGH), enabling the slave to pull it down in order to generate the acknowledge. The master polls the data line during this clock pulse and sets the NACK bit in the status register if the slave does not acknowledge the byte.

If an acknowledge is received, the master is then ready to receive data from the slave. After data has been received, the master sends an acknowledge condition to notify the slave that the data has been received except for the last data, after the stop condition. See Figure 19-9. When the RXRDY bit is set in the status register, a character has been received in the receive-holding register (RHR). The RXRDY bit is reset when reading the RHR.

When a single data byte read is performed, with or without internal address (IADR), the START and STOP bits must be set at the same time. See Figure 19-9. When a multiple data byte read is performed, with or without IADR, the STOP bit must be set after the next-to-last data received. See Figure 19-10. For Internal Address usage see "Internal Address" on page 224.

Figure 19-9. Master Read with One Data Byte

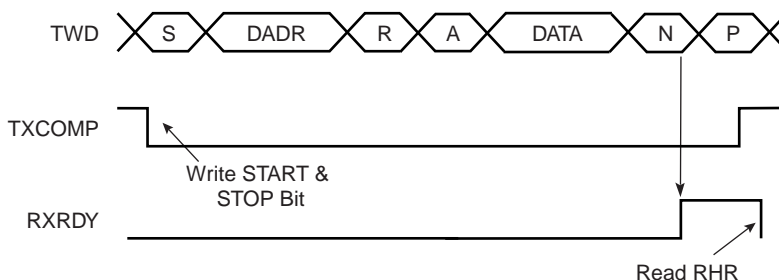
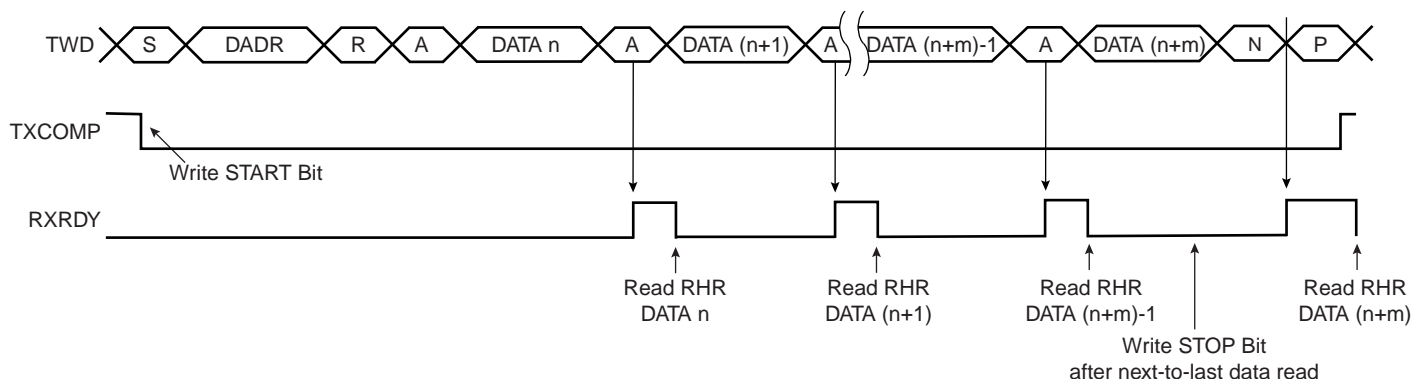

Figure 19-10. Master Read with Multiple Data Bytes



RXRDY is used as Receive Ready for the Peripheral DMA Controller receive channel.

19.10.7 Internal Address

The TWI interface can perform various transfer formats: Transfers with 7-bit slave address devices and 10-bit slave address devices.

19.10.7.1 7-bit Slave Addressing

When Addressing 7-bit slave devices, the internal address bytes are used to perform random address (read or write) accesses to reach one or more data bytes, within a memory page location in a serial memory, for example. When performing read operations with an internal address, the TWI performs a write operation to set the internal address into the slave device, and then switch to Master Receiver mode. Note that the second start condition (after sending the IADR) is sometimes called “repeated start” (Sr) in I2C fully-compatible devices. See [Figure 19-12](#). See [Figure 19-11](#) and [Figure 19-13](#) for Master Write operation with internal address.

The three internal address bytes are configurable through the Master Mode register (MMR).

If the slave device supports only a 7-bit address, i.e. no internal address, **IADRSZ** must be set to 0.

In the figures below the following abbreviations are used:

- **S** Start
- **Sr** Repeated Start
- **P** Stop
- **W** Write
- **R** Read
- **A** Acknowledge
- **N** Not Acknowledge
- **DADR** Device Address
- **IADR** Internal Address

Figure 19-11. Master Write with One, Two or Three Bytes Internal Address and One Data Byte

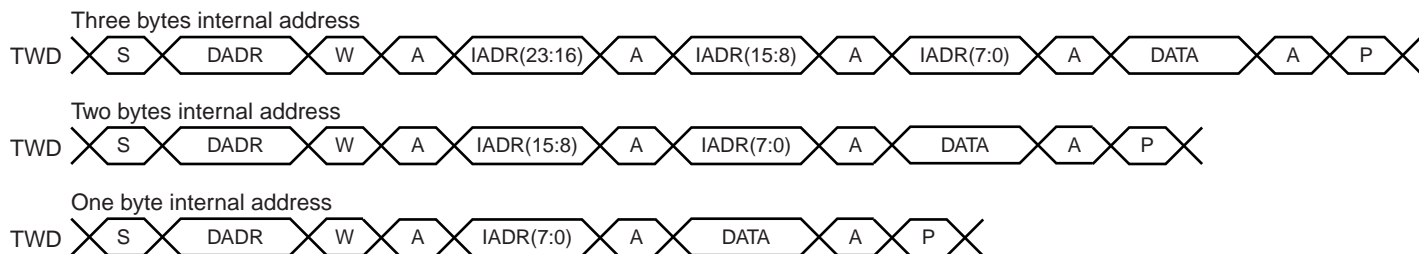
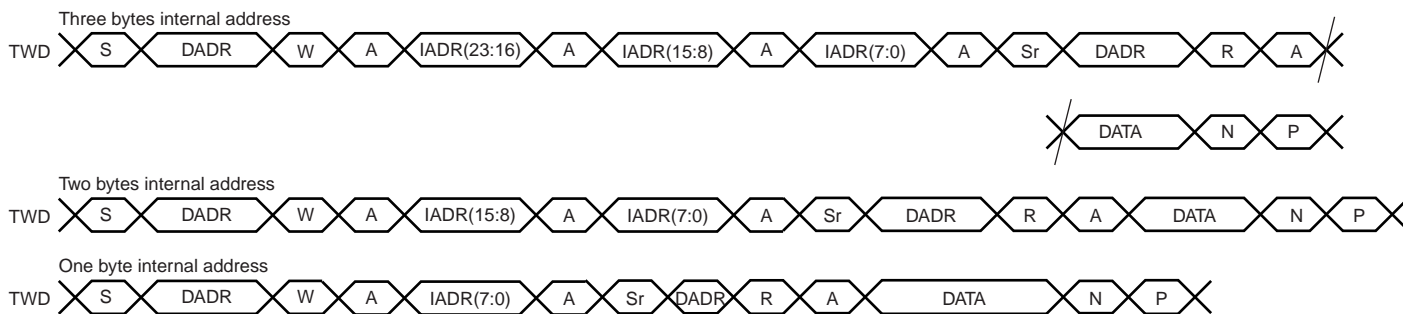

Figure 19-12. Master Read with One, Two or Three Bytes Internal Address and One Data Byte



19.10.7.2 10-bit Slave Addressing

For a slave address higher than 7 bits, the user must configure the address size (**IADRSZ**) and set the other slave address bits in the internal address register (IADR). The two remaining Internal address bytes, IADR[15:8] and IADR[23:16] can be used the same as in 7-bit Slave Addressing.

Example: Address a 10-bit device:

(10-bit device address is b1 b2 b3 b4 b5 b6 b7 b8 b9 b10)

1. Program IADRSZ = 1,
2. Program DADR with 1 1 1 1 0 b1 b2 (b1 is the MSB of the 10-bit address, b2, etc.)
3. Program IADR with b3 b4 b5 b6 b7 b8 b9 b10 (b10 is the LSB of the 10-bit address)

Figure 19-13 below shows a byte write to an Atmel AT24LC512 EEPROM. This demonstrates the use of internal addresses to access the device.

Figure 19-13. Internal Address Usage

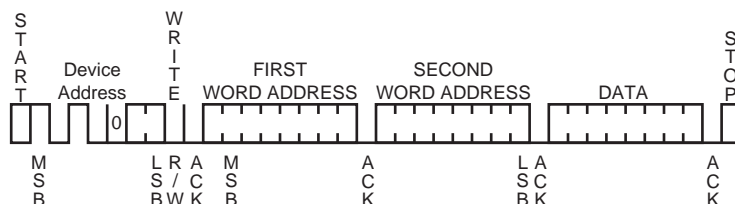

19.11 Using the Peripheral DMA Controller

The use of the Peripheral DMA Controller significantly reduces the CPU load.

To assure correct implementation, respect the following programming sequences:

19.11.1 Data Transmit with the Peripheral DMA Controller

1. Initialize the Peripheral DMA Controller TX channel (memory pointers, size, etc.).
2. Configure the master mode (DADR, CKDIV, etc.).
3. Start the transfer by setting the Peripheral DMA Controller TXEN bit.
4. Wait for the Peripheral DMA Controller end TX flag.
5. Disable the Peripheral DMA Controller by setting the Peripheral DMA Controller TXDIS bit.

19.11.2 Data Receive with the Peripheral DMA Controller

1. Initialize the Peripheral DMA Controller TX channel (memory pointers, size, etc.).
2. Configure the master mode (DADR, CKDIV, etc.).
3. Start the transfer by setting the Peripheral DMA Controller RXEN bit.
4. Wait for the Peripheral DMA Controller end RX flag.
5. Disable the Peripheral DMA Controller by setting the Peripheral DMA Controller RXDIS bit.

19.11.3 Read-write Flowcharts

The following flowcharts shown in [Figure 19-14](#) to [Figure 19-19](#) on page 233 give examples for read and write operations. A polling or interrupt method can be used to check the status bits. The interrupt method requires that the interrupt enable register (IER) be configured first.

Figure 19-14. TWI Write Operation with Single Data Byte without Internal Address.

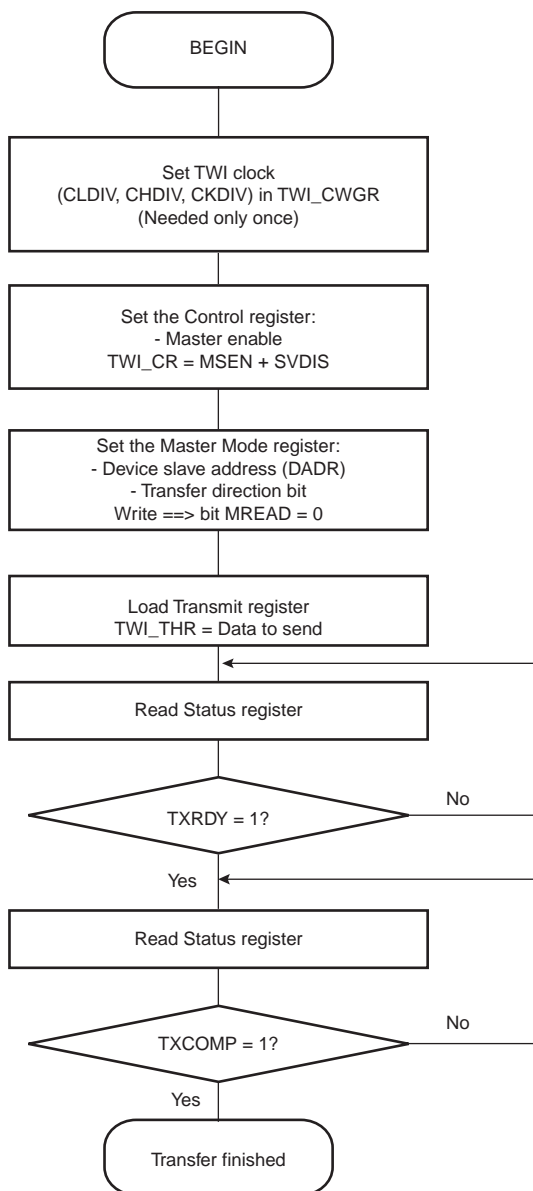

Figure 19-15. TWI Write Operation with Single Data Byte and Internal Address

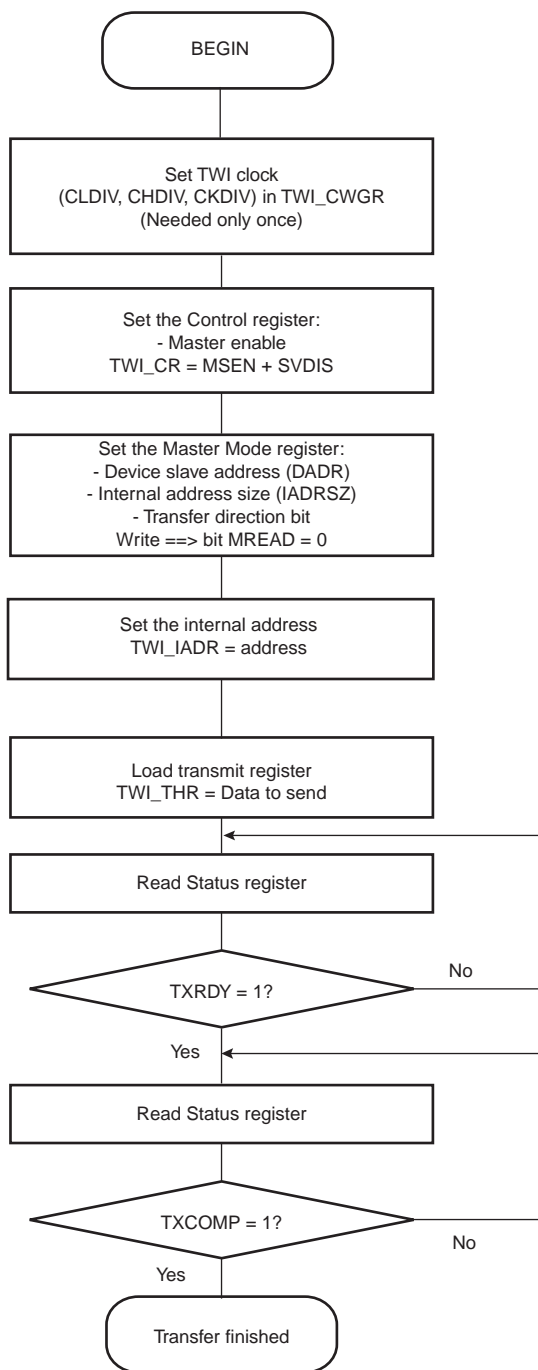

Figure 19-16. TWI Write Operation with Multiple Data Bytes with or without Internal Address

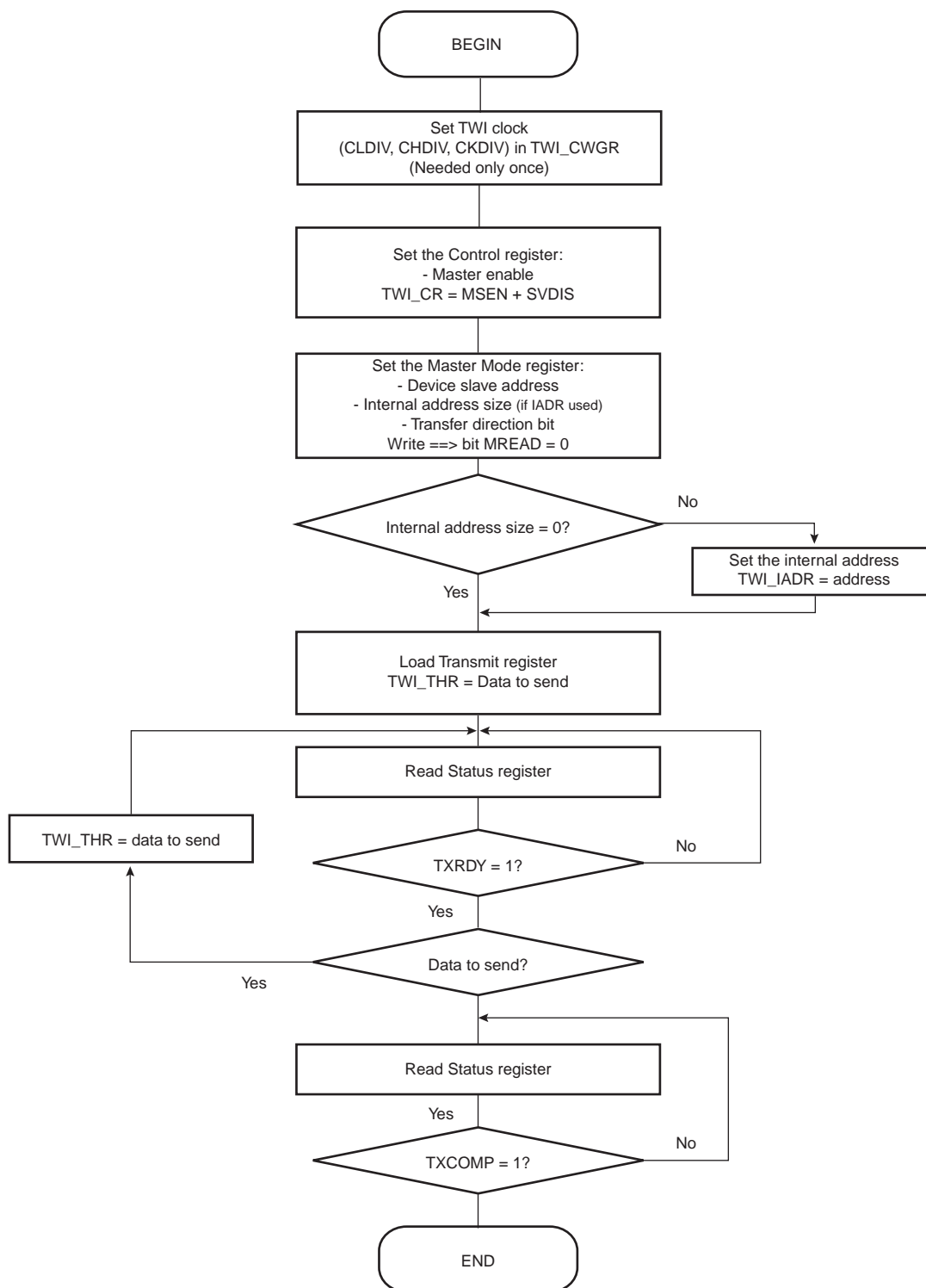

Figure 19-17. TWI Read Operation with Single Data Byte without Internal Address

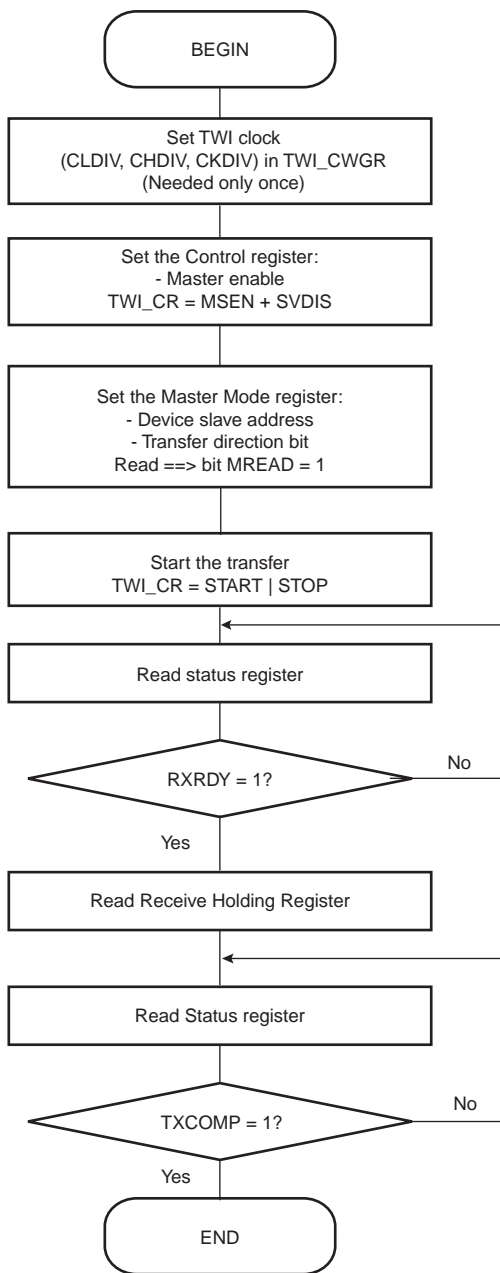

Figure 19-18. TWI Read Operation with Single Data Byte and Internal Address

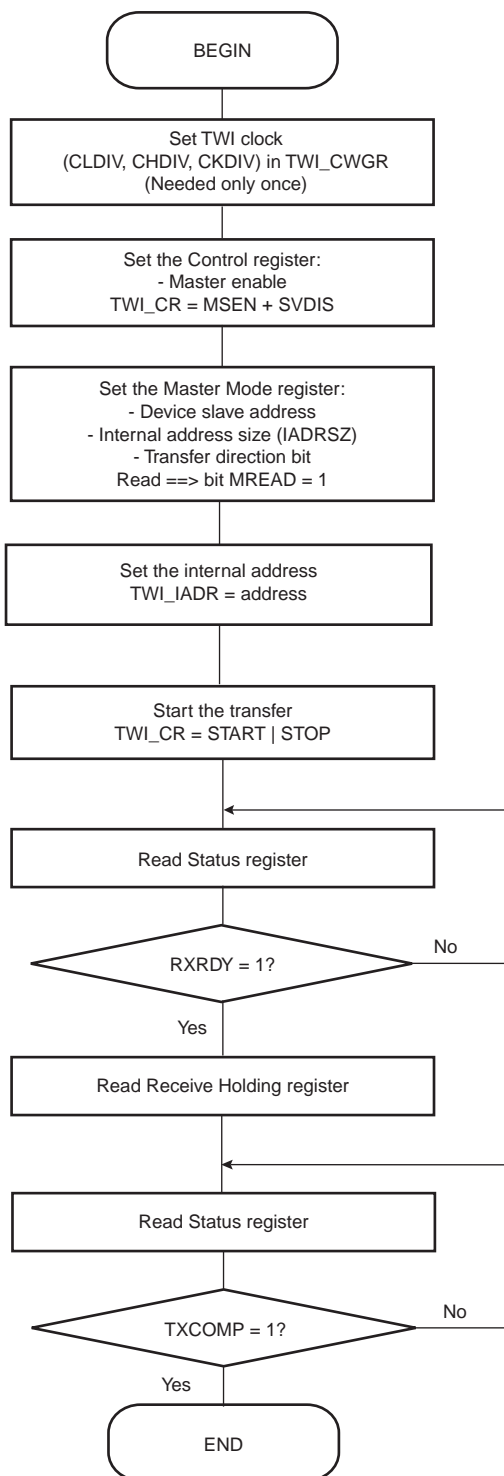
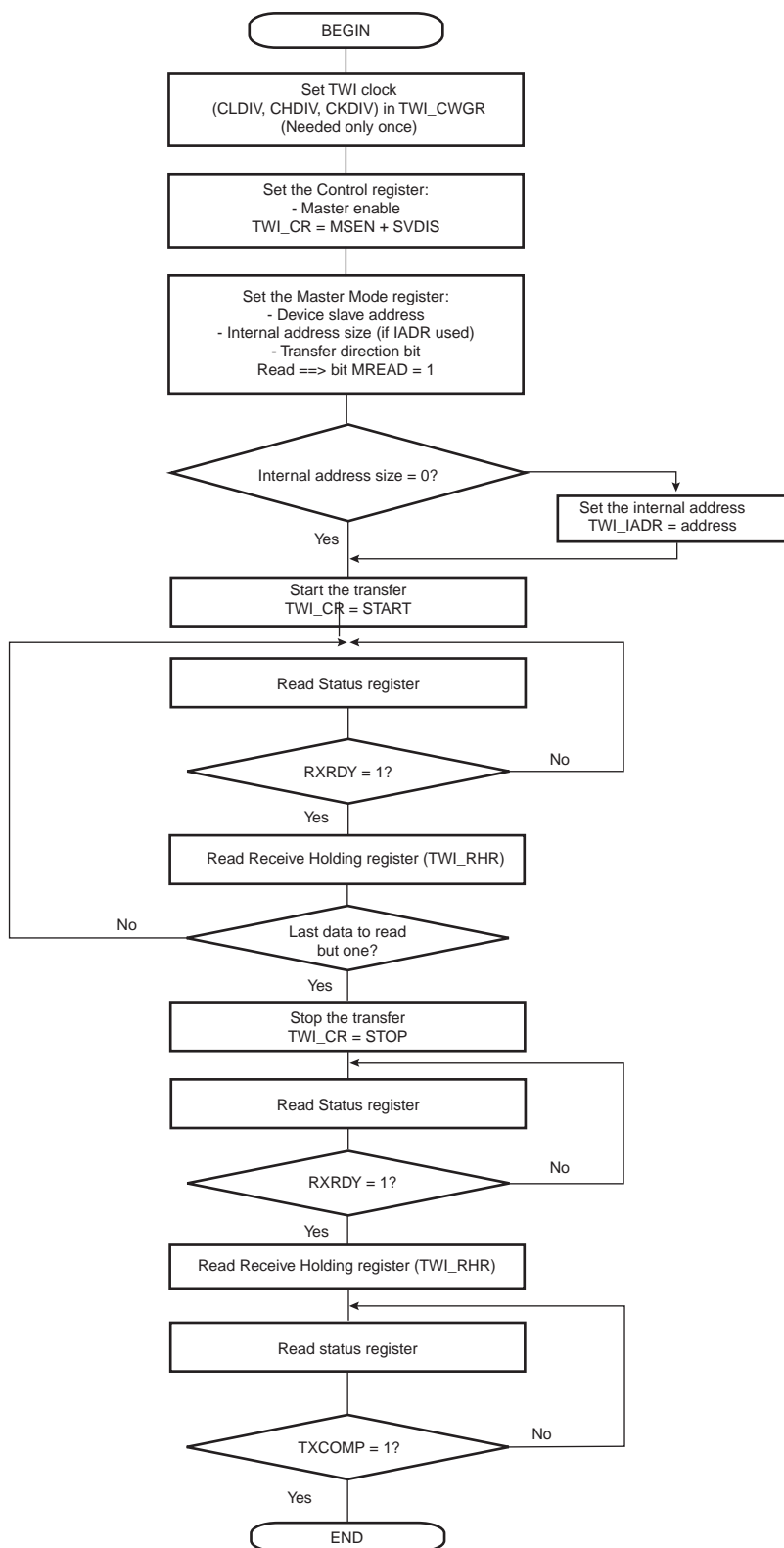

Figure 19-19. TWI Read Operation with Multiple Data Bytes with or without Internal Address



19.12 Multi-master Mode

19.12.1 Definition

More than one master may handle the bus at the same time without data corruption by using arbitration.

Arbitration starts as soon as two or more masters place information on the bus at the same time, and stops (arbitration is lost) for the master that intends to send a logical one while the other master sends a logical zero.

As soon as arbitration is lost by a master, it stops sending data and listens to the bus in order to detect a stop. When the stop is detected, the master who has lost arbitration may put its data on the bus by respecting arbitration.

Arbitration is illustrated in [Figure 19-21 on page 235](#).

19.12.2 Different Multi-master Modes

Two multi-master modes may be distinguished:

1. TWI is considered as a Master only and will never be addressed.
2. TWI may be either a Master or a Slave and may be addressed.

Note: Arbitration is supported in both Multi-master modes.

19.12.2.1 TWI as Master Only

In this mode, TWI is considered as a Master only (MSEN is always at one) and must be driven like a Master with the ARBLST (ARBitration Lost) flag in addition.

If arbitration is lost (ARBLST = 1), the programmer must reinitiate the data transfer.

If the user starts a transfer (ex.: DADR + START + W + Write in THR) and if the bus is busy, the TWI automatically waits for a STOP condition on the bus to initiate the transfer (see [Figure 19-20 on page 235](#)).

Note: The state of the bus (busy or free) is not indicated in the user interface.

19.12.2.2 TWI as Master or Slave

The automatic reversal from Master to Slave is not supported in case of a lost arbitration.

Then, in the case where TWI may be either a Master or a Slave, the programmer must manage the pseudo Multi-master mode described in the steps below.

1. Program TWI in Slave mode (SADR + MSDIS + SVEN) and perform Slave Access (if TWI is addressed).
2. If TWI has to be set in Master mode, wait until TXCOMP flag is at 1.
3. Program Master mode (DADR + SVDIS + MSEN) and start the transfer (ex: START + Write in THR).
4. As soon as the Master mode is enabled, TWI scans the bus in order to detect if it is busy or free. When the bus is considered as free, TWI initiates the transfer.
5. As soon as the transfer is initiated and until a STOP condition is sent, the arbitration becomes relevant and the user must monitor the ARBLST flag.
6. If the arbitration is lost (ARBLST is set to 1), the user must program the TWI in Slave mode in the case where the Master that won the arbitration wanted to access the TWI.

- If TWI has to be set in Slave mode, wait until TXCOMP flag is at 1 and then program the Slave mode.

Note: In the case where the arbitration is lost and TWI is addressed, TWI will not acknowledge even if it is programmed in Slave mode as soon as ARBLST is set to 1. Then, the Master must repeat SADR.

Figure 19-20. Programmer Sends Data While the Bus is Busy

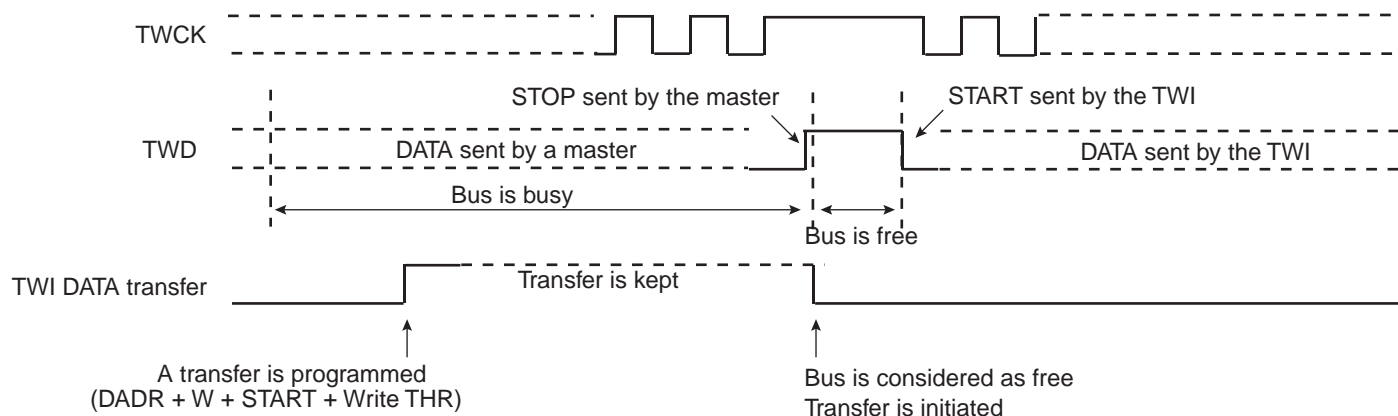
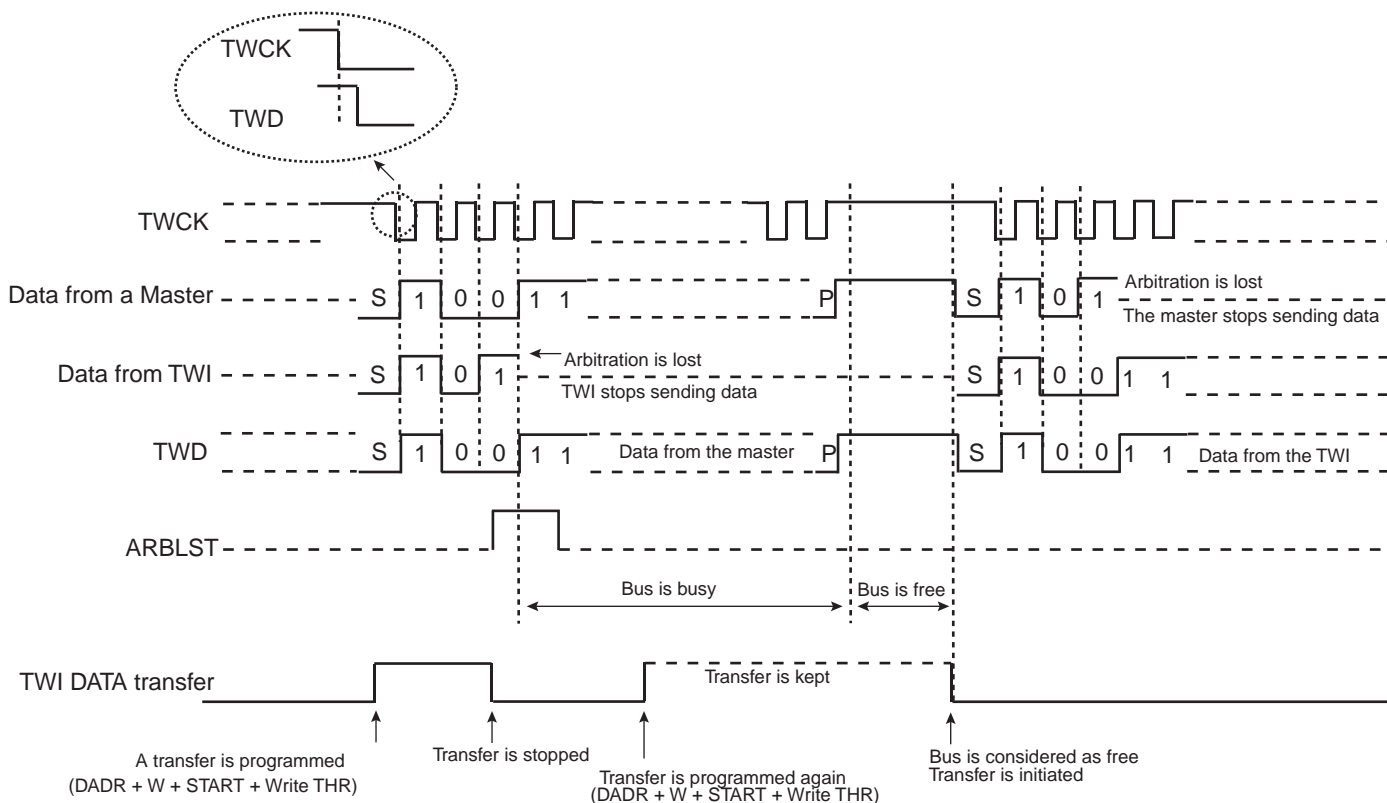
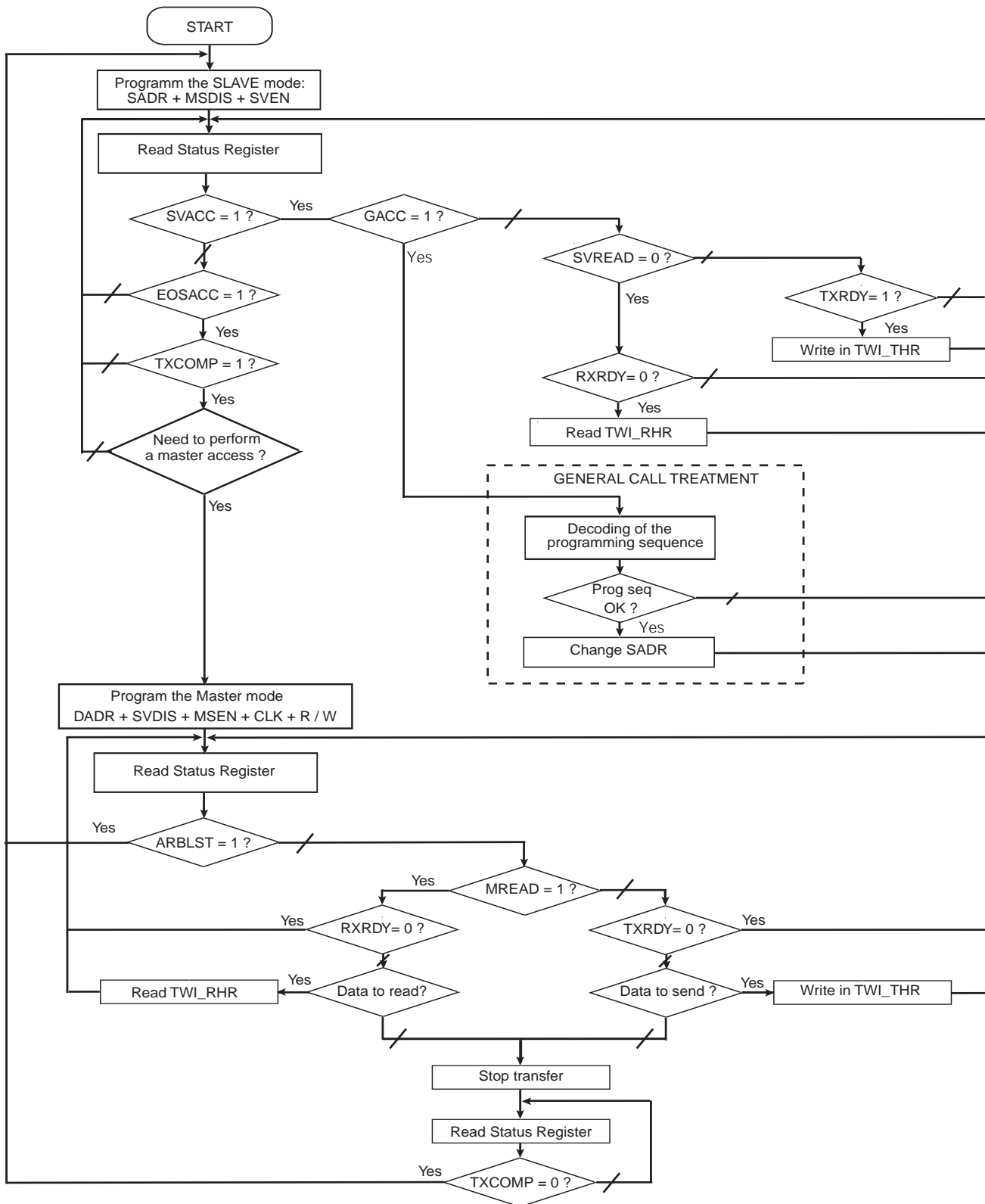

Figure 19-21. Arbitration Cases



The flowchart shown in [Figure 19-22 on page 236](#) gives an example of read and write operations in Multi-master mode.

Figure 19-22. Multi-master Flowchart



19.13 Slave Mode

19.13.1 Definition

The Slave Mode is defined as a mode where the device receives the clock and the address from another device called the master.

In this mode, the device never initiates and never completes the transmission (START, REPEATED_START and STOP conditions are always provided by the master).

19.13.2 Application Block Diagram

Figure 19-23. Slave Mode Typical Application Block Diagram

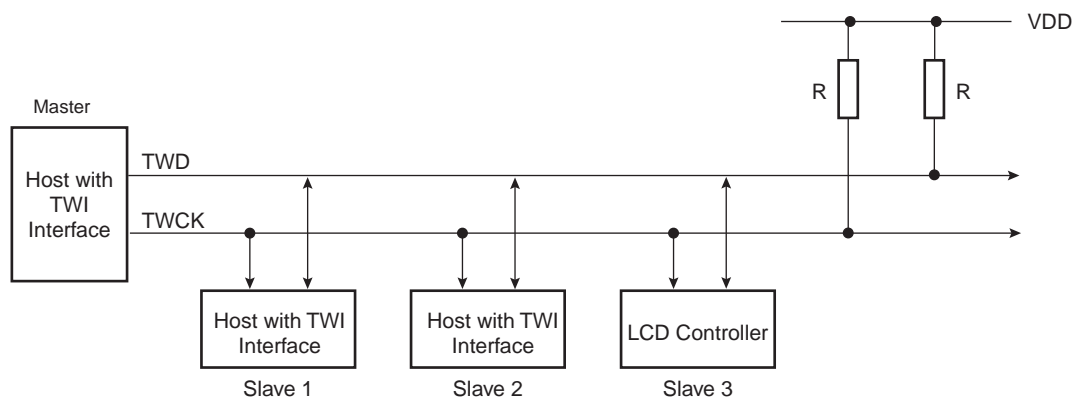

19.13.3 Programming Slave Mode

The following fields must be programmed before entering Slave mode:

1. SADR (SMR): The slave device address is used in order to be accessed by master devices in read or write mode.
2. MSDIS (CR): Disable the master mode.
3. SVEN (CR): Enable the slave mode.

As the device receives the clock, values written in CWGR are not taken into account.

19.13.4 Receiving Data

After a Start or Repeated Start condition is detected and if the address sent by the Master matches with the Slave address programmed in the SADR (Slave Address) field, SVACC (Slave ACCess) flag is set and SVREAD (Slave READ) indicates the direction of the transfer.

SVACC remains high until a STOP condition or a repeated START is detected. When such a condition is detected, EOSACC (End Of Slave ACCess) flag is set.

19.13.4.1 Read Sequence

In the case of a Read sequence (SVREAD is high), TWI transfers data written in the THR (TWI Transmit Holding Register) until a STOP condition or a REPEATED_START + an address different from SADR is detected. Note that at the end of the read sequence TXCOMP (Transmission Complete) flag is set and SVACC reset.

As soon as data is written in the THR, TXRDY (Transmit Holding Register Ready) flag is reset, and it is set when the shift register is empty and the sent data acknowledged or not. If the data is not acknowledged, the NACK flag is set.

Note that a STOP or a repeated START always follows a NACK.

See [Figure 19-24 on page 239](#).

19.13.4.2 Write Sequence

In the case of a Write sequence (SVREAD is low), the RXRDY (Receive Holding Register Ready) flag is set as soon as a character has been received in the RHR (TWI Receive Holding Register). RXRDY is reset when reading the RHR.

TWI continues receiving data until a STOP condition or a REPEATED_START + an address different from SADR is detected. Note that at the end of the write sequence TXCOMP flag is set and SVACC reset.

See [Figure 19-25 on page 239](#).

19.13.4.3 Clock Synchronization Sequence

In the case where THR or RHR is not written/read in time, TWI performs a clock synchronization.

Clock stretching information is given by the SCLWS (Clock Wait state) bit.

See [Figure 19-27 on page 241](#) and [Figure 19-28 on page 242](#).

19.13.4.4 General Call

In the case where a GENERAL CALL is performed, GACC (General Call ACCess) flag is set.

After GACC is set, it is up to the programmer to interpret the meaning of the GENERAL CALL and to decode the new address programming sequence.

See [Figure 19-26 on page 240](#).

19.13.4.5 Peripheral DMA Controller

As it is impossible to know the exact number of data to receive/send, the use of Peripheral DMA Controller is NOT recommended in SLAVE mode.

19.13.5 Data Transfer

19.13.5.1 Read Operation

The read mode is defined as a data requirement from the master.

After a START or a REPEATED START condition is detected, the decoding of the address starts. If the slave address (SADR) is decoded, SVACC is set and SVREAD indicates the direction of the transfer.

Until a STOP or REPEATED START condition is detected, TWI continues sending data loaded in the THR register.

If a STOP condition or a REPEATED START + an address different from SADR is detected, SVACC is reset.

[Figure 19-24 on page 239](#) describes the write operation.

Figure 19-24. Read Access Ordered by a MASTER

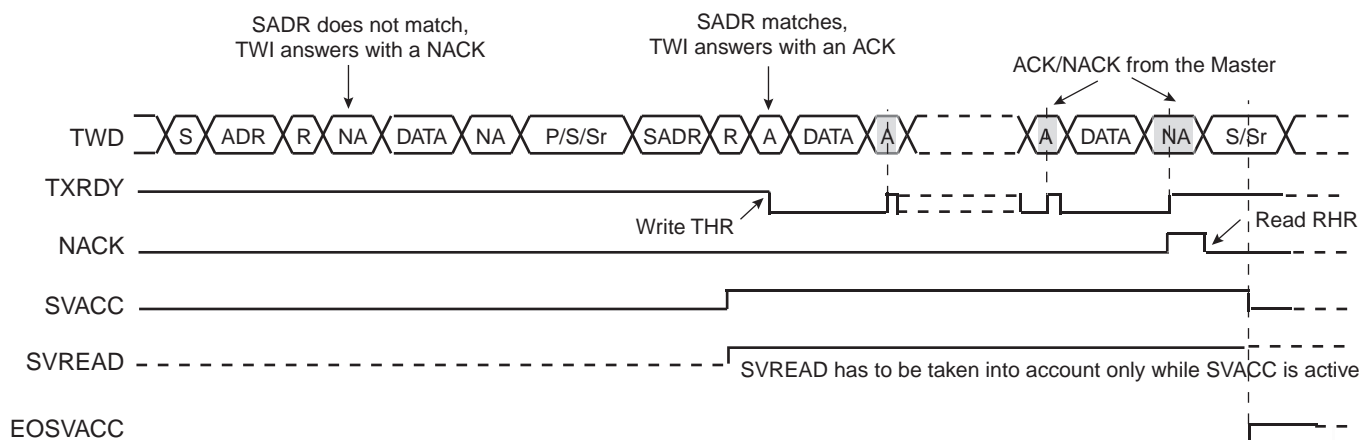

- Notes:
1. When SVACC is low, the state of SVREAD becomes irrelevant.
 2. TXRDY is reset when data has been transmitted from THR to the shift register and set when this data has been acknowledged or non acknowledged.

19.13.5.2 Write Operation

The write mode is defined as a data transmission from the master.

After a START or a REPEATED START, the decoding of the address starts. If the slave address is decoded, SVACC is set and SVREAD indicates the direction of the transfer (SVREAD is low in this case).

Until a STOP or REPEATED START condition is detected, TWI stores the received data in the RHR register.

If a STOP condition or a REPEATED START + an address different from SADR is detected, SVACC is reset.

Figure 19-25 on page 239 describes the Write operation.

Figure 19-25. Write Access Ordered by a Master

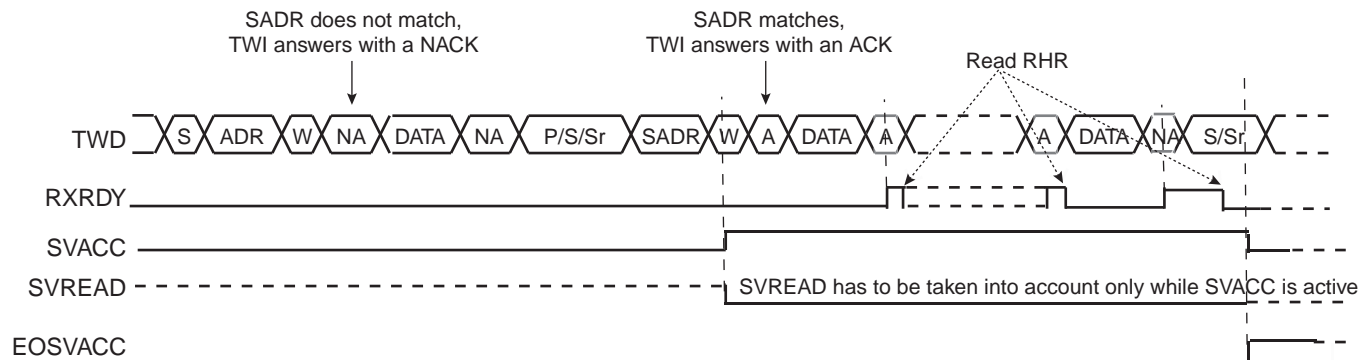

- Notes:
1. When SVACC is low, the state of SVREAD becomes irrelevant.
 2. RXRDY is set when data has been transmitted from the shift register to the RHR and reset when this data is read.

19.13.5.3 General Call

The general call is performed in order to change the address of the slave.

If a GENERAL CALL is detected, GACC is set.

After the detection of General Call, it is up to the programmer to decode the commands which come afterwards.

In case of a WRITE command, the programmer has to decode the programming sequence and program a new SADR if the programming sequence matches.

Figure 19-26 on page 240 describes the General Call access.

Figure 19-26. Master Performs a General Call

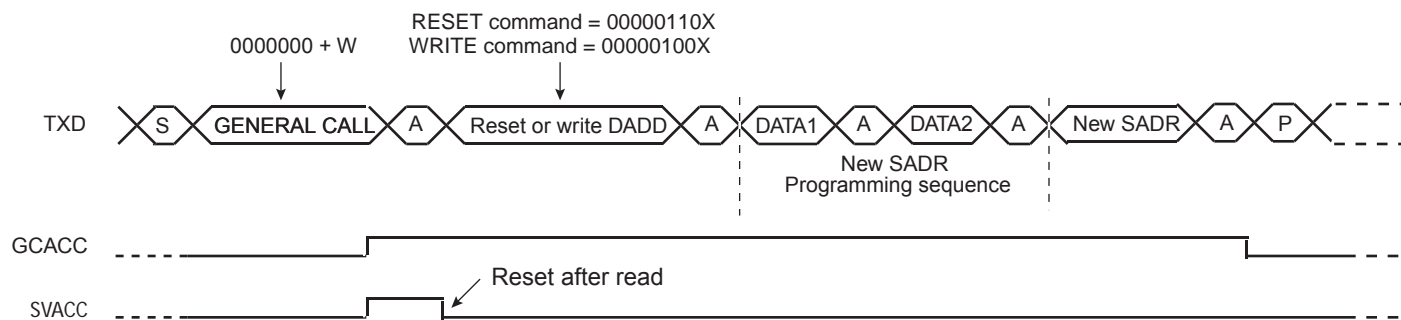

- Note:
1. This method allows the user to create an own programming sequence by choosing the programming bytes and the number of them. The programming sequence has to be provided to the master.

19.13.6 Clock Synchronization

In both read and write modes, it may happen that THR/RHR buffer is not filled /emptied before the emission/reception of a new character. In this case, to avoid sending/receiving undesired data, a clock stretching mechanism is implemented.

19.13.6.1 Clock Synchronization in Read Mode

The clock is tied low if the shift register is empty and if a STOP or REPEATED START condition was not detected. It is tied low until the shift register is loaded.

Figure 19-27 on page 241 describes the clock synchronization in Read mode.

Figure 19-27. Clock Synchronization in Read Mode

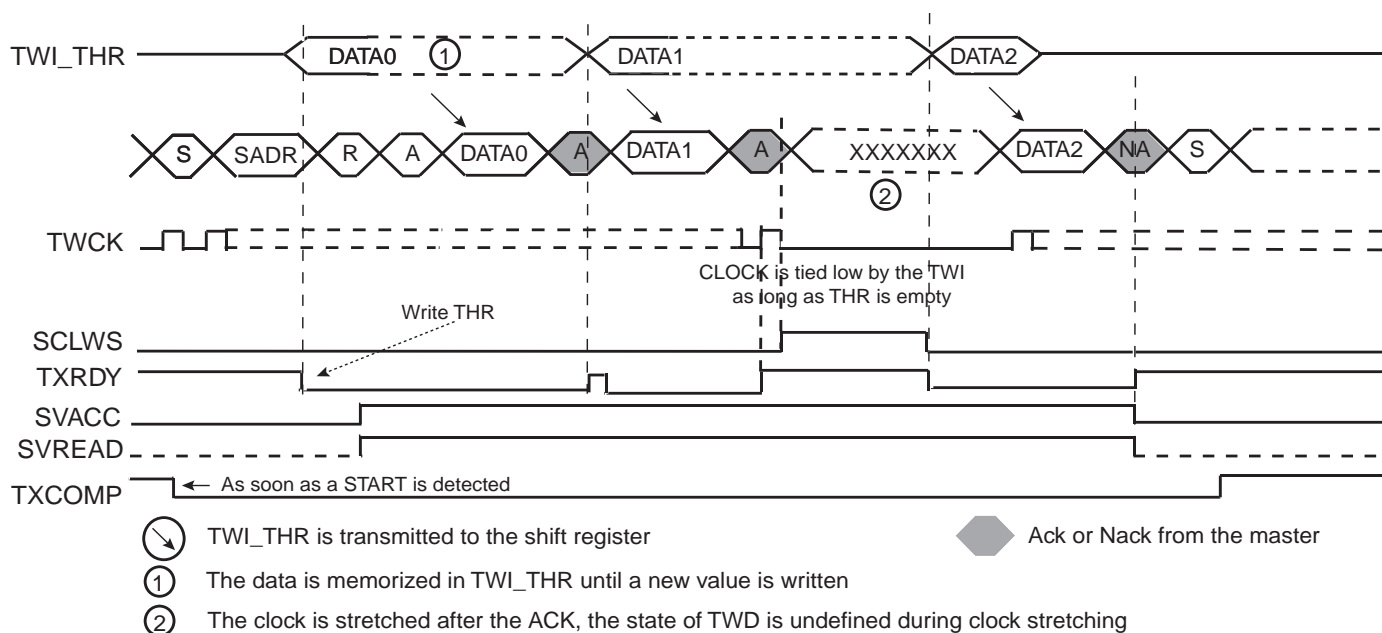

- Notes:
1. TXRDY is reset when data has been written in the TH to the shift register and set when this data has been acknowledged or non acknowledged.
 2. At the end of the read sequence, TXCOMP is set after a STOP or after a REPEATED_START + an address different from SADR.
 3. SCLWS is automatically set when the clock synchronization mechanism is started.

19.13.6.2 Clock Synchronization in Write Mode

The clock is tied low if the shift register and the RHR is full. If a STOP or REPEATED_START condition was not detected, it is tied low until RHR is read.

Figure 19-28 on page 242 describes the clock synchronization in Read mode.

Figure 19-28. Clock Synchronization in Write Mode

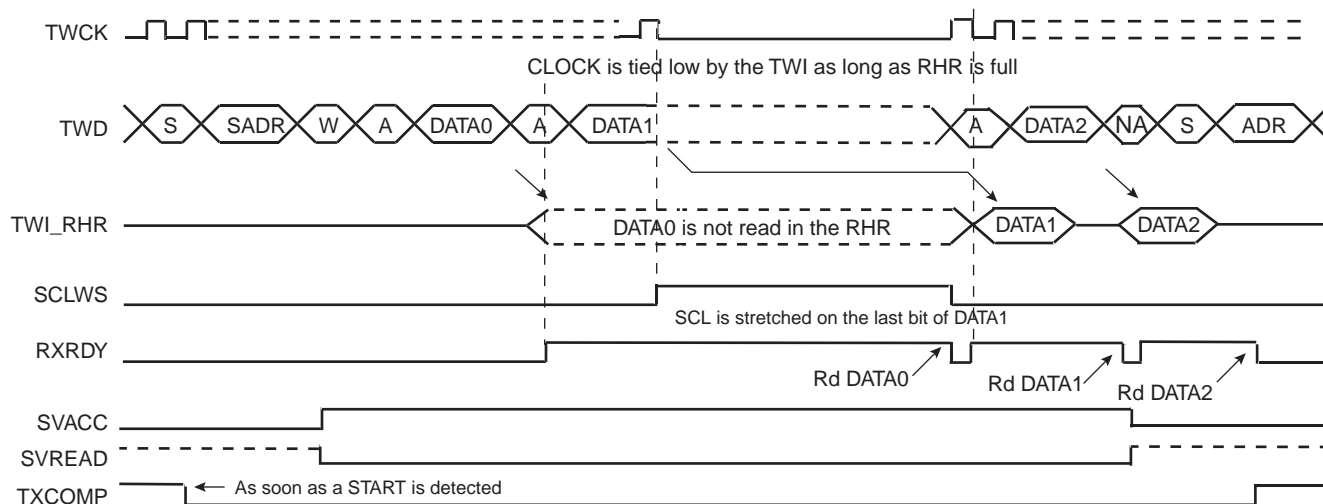

- Notes:
1. At the end of the read sequence, TXCOMP is set after a STOP or after a REPEATED_START + an address different from SADR.
 2. SCLWS is automatically set when the clock synchronization mechanism is started and automatically reset when the mechanism is finished.

19.13.7 Reversal after a Repeated Start

19.13.7.1 Reversal of Read to Write

The master initiates the communication by a read command and finishes it by a write command.

Figure 19-29 on page 243 describes the repeated start + reversal from Read to Write mode.

Figure 19-29. Repeated Start + Reversal from Read to Write Mode

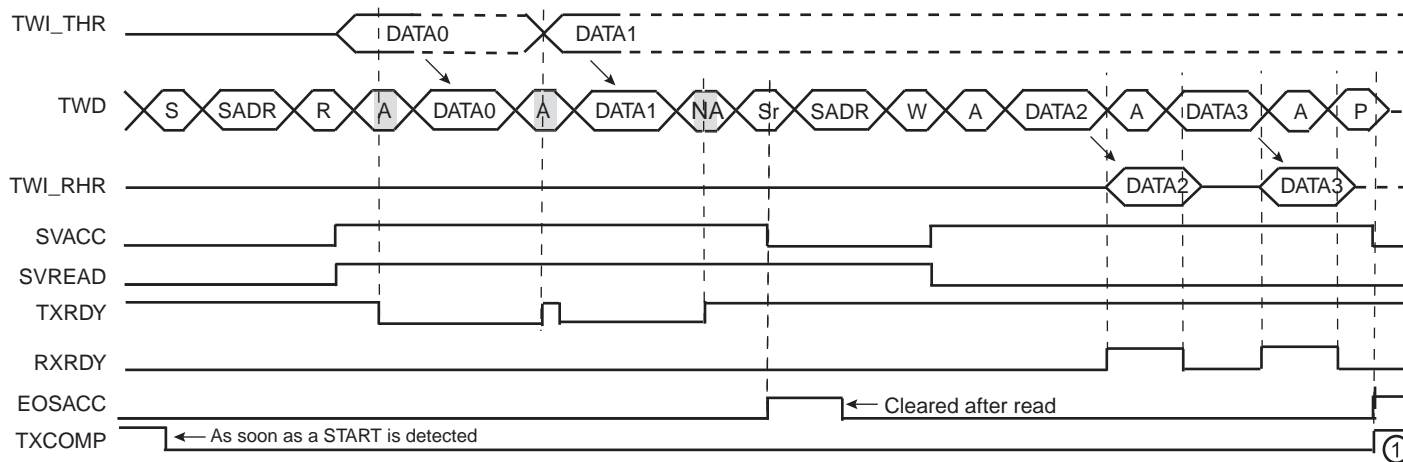

Note: 1. TXCOMP is only set at the end of the transmission because after the repeated start, SADR is detected again.

19.13.7.2 Reversal of Write to Read

The master initiates the communication by a write command and finishes it by a read command. Figure 19-30 on page 243 describes the repeated start + reversal from Write to Read mode.

Figure 19-30. Repeated Start + Reversal from Write to Read Mode

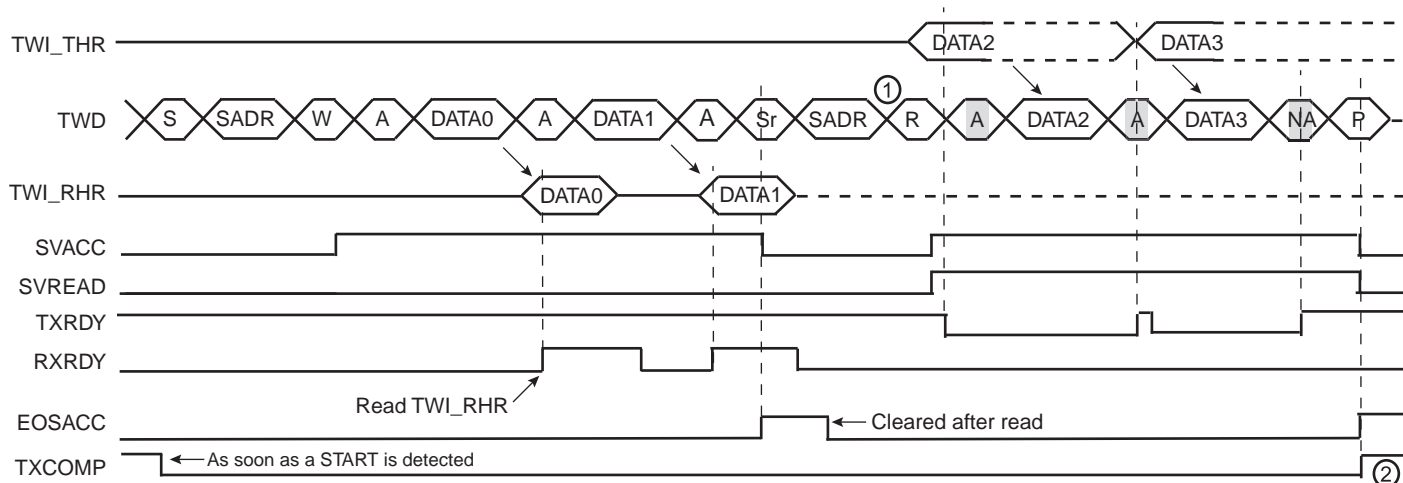

Notes: 1. In this case, if THR has not been written at the end of the read command, the clock is automatically stretched before the ACK.



2. TXCOMP is only set at the end of the transmission because after the repeated start, SADR is detected again.

19.13.8 Read Write Flowcharts

The flowchart shown in Figure 19-31 on page 244 gives an example of read and write operations in Slave mode. A polling or interrupt method can be used to check the status bits. The interrupt method requires that the interrupt enable register (IER) be configured first.

Figure 19-31. Read Write Flowchart in Slave Mode

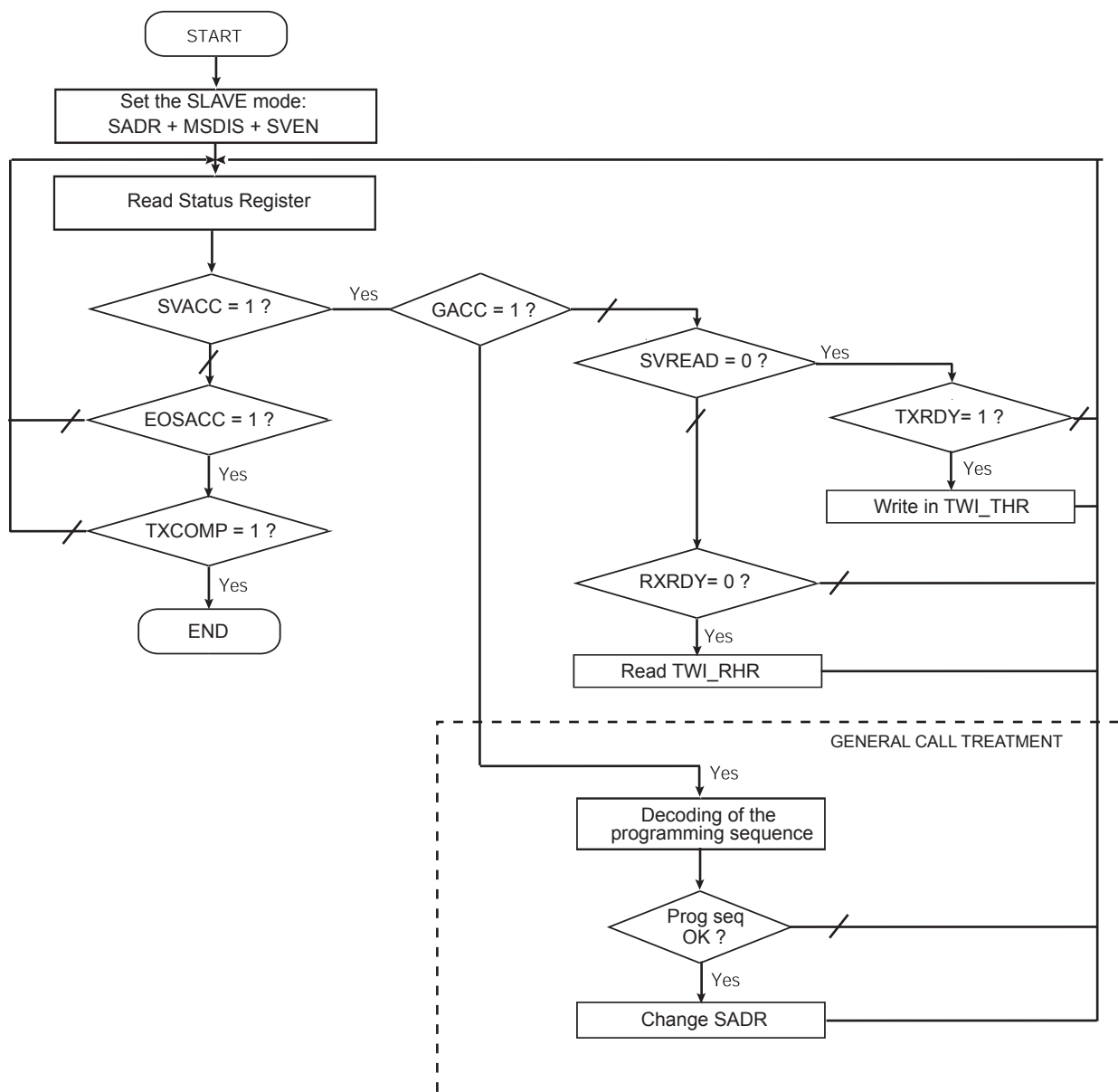

19.14 User Interface

Table 19-4. TWI User Interface

| Offset | Register | Register Name | Access | Reset |
|--------|-----------------------------------|---------------|------------|------------|
| 0x00 | Control Register | CR | Write-only | N / A |
| 0x04 | Master Mode Register | MMR | Read/Write | 0x00000000 |
| 0x08 | Slave Mode Register | SMR | Read/Write | 0x00000000 |
| 0x0C | Internal Address Register | IADR | Read/Write | 0x00000000 |
| 0x10 | Clock Waveform Generator Register | CWGR | Read/Write | 0x00000000 |
| 0x20 | Status Register | SR | Read-only | 0x0000F009 |
| 0x24 | Interrupt Enable Register | IER | Write-only | N / A |
| 0x28 | Interrupt Disable Register | IDR | Write-only | N / A |
| 0x2C | Interrupt Mask Register | IMR | Read-only | 0x00000000 |
| 0x30 | Receive Holding Register | RHR | Read-only | 0x00000000 |
| 0x34 | Transmit Holding Register | THR | Write-only | 0x00000000 |

19.14.1 Control Register

Name: CR

Access: Write-only

Offset: 0x00

Reset Value: 0x00000000

| | | | | | | | |
|-------|----|-------|------|-------|------|------|-------|
| 31 | 30 | 29 | 28 | 27 | 26 | 25 | 24 |
| – | – | – | – | – | – | – | – |
| 23 | 22 | 21 | 20 | 19 | 18 | 17 | 16 |
| – | – | – | – | – | – | – | – |
| 15 | 14 | 13 | 12 | 11 | 10 | 9 | 8 |
| – | – | – | – | – | – | – | – |
| 7 | 6 | 5 | 4 | 3 | 2 | 1 | 0 |
| SWRST | – | SVDIS | SVEN | MSDIS | MSEN | STOP | START |

- **SWRST: Software Reset**

0 = No effect.

1 = Equivalent to a system reset.

- **SVDIS: TWI Slave Mode Disabled**

0 = No effect.

1 = The slave mode is disabled. The shifter and holding characters (if it contains data) are transmitted in case of read operation. In write operation, the character being transferred must be completely received before disabling.

- **SVEN: TWI Slave Mode Enabled**

0 = No effect.

1 = If SVDIS = 0, the slave mode is enabled.

Switching from Master to Slave mode is only permitted when TXCOMP = 1.

- **MSDIS: TWI Master Mode Disabled**

0 = No effect.

1 = The master mode is disabled, all pending data is transmitted. The shifter and holding characters (if it contains data) are transmitted in case of write operation. In read operation, the character being transferred must be completely received before disabling.

- **MSEN: TWI Master Mode Enabled**

0 = No effect.

1 = If MSDIS = 0, the master mode is enabled.

Switching from Slave to Master mode is only permitted when TXCOMP = 1.

- **STOP: Send a STOP Condition**

0 = No effect.

1 = STOP Condition is sent just after completing the current byte transmission in master read mode.

- In single data byte master read, the START and STOP must both be set.

- In multiple data bytes master read, the STOP must be set after the last data received but one.

- In master read mode, if a NACK bit is received, the STOP is automatically performed.

- In multiple data write operation, when both THR and shift register are empty, a STOP condition is automatically sent.

- **START: Send a START Condition**

0 = No effect.

1 = A frame beginning with a START bit is transmitted according to the features defined in the mode register.

This action is necessary when the TWI peripheral wants to read data from a slave. When configured in Master Mode with a write operation, a frame is sent as soon as the user writes a character in the Transmit Holding Register (THR).

19.14.2 Master Mode Register

Name: MMR

Access: Read-write

Offset: 0x04

Reset Value: 0x00000000

| | | | | | | | |
|----|------|----|-------|----|----|--------|----|
| 31 | 30 | 29 | 28 | 27 | 26 | 25 | 24 |
| – | – | – | – | – | – | – | – |
| 23 | 22 | 21 | 20 | 19 | 18 | 17 | 16 |
| – | DADR | | | | | | – |
| 15 | 14 | 13 | 12 | 11 | 10 | 9 | 8 |
| – | – | – | MREAD | – | – | IADRSZ | |
| 7 | 6 | 5 | 4 | 3 | 2 | 1 | 0 |
| – | – | – | – | – | – | – | – |

- **DADR: Device Address**

The device address is used to access slave devices in read or write mode. Those bits are only used in Master mode.

- **MREAD: Master Read Direction**

0 = Master write direction.

1 = Master read direction.

- **IADRSZ: Internal Device Address Size**

| IADRSZ[9:8] | | Description |
|-------------|---|------------------------------------|
| 0 | 0 | No internal device address |
| 0 | 1 | One-byte internal device address |
| 1 | 0 | Two-byte internal device address |
| 1 | 1 | Three-byte internal device address |

19.14.3 Slave Mode Register

Name: SMR

Access: Read-write

Offset: 0x08

Reset Value: 0x00000000

| | | | | | | | |
|----|------|----|----|----|----|----|----|
| 31 | 30 | 29 | 28 | 27 | 26 | 25 | 24 |
| - | - | - | - | - | - | - | - |
| 23 | 22 | 21 | 20 | 19 | 18 | 17 | 16 |
| - | SADR | | | | | | |
| 15 | 14 | 13 | 12 | 11 | 10 | 9 | 8 |
| - | - | - | - | - | - | | |
| 7 | 6 | 5 | 4 | 3 | 2 | 1 | 0 |
| - | - | - | - | - | - | - | - |

- **SADR: Slave Address**

The slave device address is used in Slave mode in order to be accessed by master devices in read or write mode.

SADR must be programmed before enabling the Slave mode or after a general call. Writes at other times have no effect.

19.14.4 Internal Address Register

Name: IADR

Access: Read-write

Offset: 0x0C

Reset Value: 0x00000000

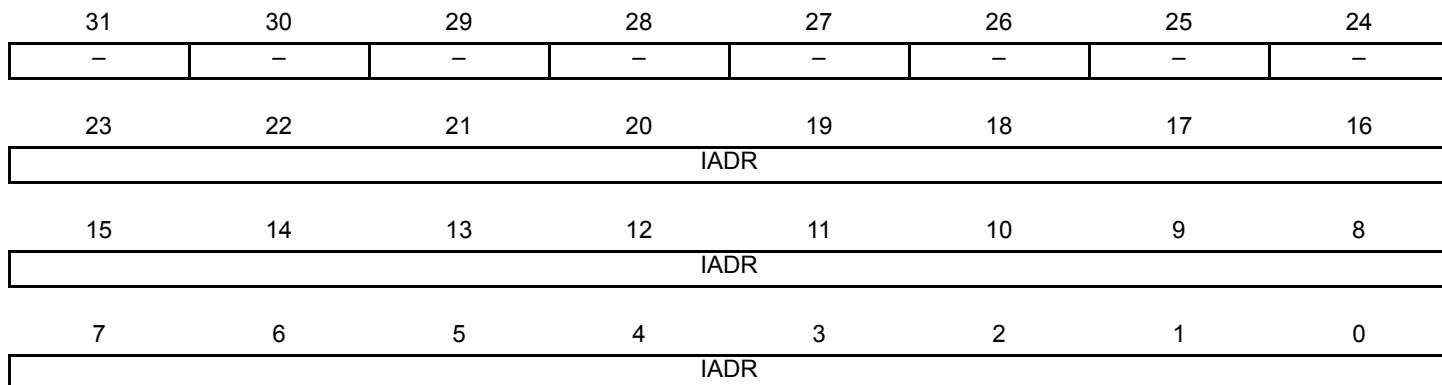

- **IADR: Internal Address**
0, 1, 2 or 3 bytes depending on IADRSZ.

19.14.5 Clock Waveform Generator Register

Name: CWGR

Access: Read-write

Offset: 0x10

Reset Value: 0x00000000

| | | | | | | | |
|-------|----|----|----|----|----|-------|----|
| 31 | 30 | 29 | 28 | 27 | 26 | 25 | 24 |
| – | – | – | – | – | – | – | – |
| 23 | 22 | 21 | 20 | 19 | 18 | 17 | 16 |
| | | | | | | CKDIV | |
| 15 | 14 | 13 | 12 | 11 | 10 | 9 | 8 |
| CHDIV | | | | | | | |
| 7 | 6 | 5 | 4 | 3 | 2 | 1 | 0 |
| CLDIV | | | | | | | |

CWGR is only used in Master mode.

- **CKDIV: Clock Divider**
The CKDIV is used to increase both SCL high and low periods.
- **CHDIV: Clock High Divider**
The SCL high period is defined as follows:

$$T_{high} = ((CHDIV \times 2^{CKDIV}) + 4) \times T_{CLK_TWI}$$
- **CLDIV: Clock Low Divider**
The SCL low period is defined as follows:

$$T_{low} = ((CLDIV \times 2^{CKDIV}) + 4) \times T_{CLK_TWI}$$

19.14.6 Status Register

Name: SR

Access: Read-only

Offset: 0x20

Reset Value: 0x0000F009

| | | | | | | | |
|----|------|------|-------|--------|-------|--------|--------|
| 31 | 30 | 29 | 28 | 27 | 26 | 25 | 24 |
| - | - | - | - | - | - | - | - |
| 23 | 22 | 21 | 20 | 19 | 18 | 17 | 16 |
| - | - | - | - | - | - | - | - |
| 15 | 14 | 13 | 12 | 11 | 10 | 9 | 8 |
| - | - | - | - | EOSACC | SCLWS | ARBLST | NACK |
| 7 | 6 | 5 | 4 | 3 | 2 | 1 | 0 |
| - | OVRE | GACC | SVACC | SVREAD | TXRDY | RXRDY | TXCOMP |

- **EOSACC: End Of Slave Access (clear on read)**

This bit is only used in Slave mode.

0 = A slave access is being performing.

1 = The Slave Access is finished. End Of Slave Access is automatically set as soon as SVACC is reset.

EOSACC behavior can be seen in [Figure 19-29 on page 243](#) and [Figure 19-30 on page 243](#)

- **SCLWS: Clock Wait State (automatically set / reset)**

This bit is only used in Slave mode.

0 = The clock is not stretched.

1 = The clock is stretched. THR / RHR buffer is not filled / emptied before the emission / reception of a new character.

SCLWS behavior can be seen in [Figure 19-27 on page 241](#) and [Figure 19-28 on page 242](#).

- **ARBLST: Arbitration Lost (clear on read)**

This bit is only used in Master mode.

0 = Arbitration won.

1 = Arbitration lost. Another master of the TWI bus has won the multi-master arbitration. TXCOMP is set at the same time.

- **NACK: Not Acknowledged (clear on read)**

NACK used in Master mode:

0 = Each data byte has been correctly received by the far-end side TWI slave component.

1 = A data byte has not been acknowledged by the slave component. Set at the same time as TXCOMP.

NACK used in Slave Read mode:

0 = Each data byte has been correctly received by the Master.

1 = In read mode, a data byte has not been acknowledged by the Master. When NACK is set the programmer must not fill THR even if TXRDY is set, because it means that the Master will stop the data transfer or re initiate it.

Note that in Slave Write mode all data are acknowledged by the TWI.

- **OVRE: Overrun Error (clear on read)**

This bit is only used in Slave mode.

0 = RHR has not been loaded while RXRDY was set

1 = RHR has been loaded while RXRDY was set. Reset by read in SR when TXCOMP is set.

- **GACC: General Call Access (clear on read)**

This bit is only used in Slave mode.

0 = No General Call has been detected.



1 = A General Call has been detected. After the detection of General Call, the programmer decoded the commands that follow and the programming sequence.

GACC behavior can be seen in [Figure 19-26 on page 240](#).

- **SVACC: Slave Access (automatically set / reset)**

This bit is only used in Slave mode.

0 = TWI is not addressed. SVACC is automatically cleared after a NACK or a STOP condition is detected.

1 = Indicates that the address decoding sequence has matched (A Master has sent SADR). SVACC remains high until a NACK or a STOP condition is detected.

SVACC behavior can be seen in [Figure 19-24 on page 239](#), [Figure 19-25 on page 239](#), [Figure 19-29 on page 243](#) and [Figure 19-30 on page 243](#).

- **SVREAD: Slave Read (automatically set / reset)**

This bit is only used in Slave mode. When SVACC is low (no Slave access has been detected) SVREAD is irrelevant.

0 = Indicates that a write access is performed by a Master.

1 = Indicates that a read access is performed by a Master.

SVREAD behavior can be seen in [Figure 19-24 on page 239](#), [Figure 19-25 on page 239](#), [Figure 19-29 on page 243](#) and [Figure 19-30 on page 243](#).

- **TXRDY: Transmit Holding Register Ready (automatically set / reset)**

TXRDY used in Master mode:

0 = The transmit holding register has not been transferred into shift register. Set to 0 when writing into THR register.

1 = As soon as a data byte is transferred from THR to internal shifter or if a NACK error is detected, TXRDY is set at the same time as TXCOMP and NACK. TXRDY is also set when MSEN is set (enable TWI).

TXRDY behavior in Master mode can be seen in [Figure 19-8 on page 223](#).

TXRDY used in Slave mode:

0 = As soon as data is written in the THR, until this data has been transmitted and acknowledged (ACK or NACK).

1 = It indicates that the THR is empty and that data has been transmitted and acknowledged.

If TXRDY is high and if a NACK has been detected, the transmission will be stopped. Thus when TRDY = NACK = 1, the programmer must not fill THR to avoid losing it.

TXRDY behavior in Slave mode can be seen in [Figure 19-24 on page 239](#), [Figure 19-27 on page 241](#), [Figure 19-29 on page 243](#) and [Figure 19-30 on page 243](#).

- **RXRDY: Receive Holding Register Ready (automatically set / reset)**

0 = No character has been received since the last RHR read operation.

1 = A byte has been received in the RHR since the last read.

RXRDY behavior in Master mode can be seen in [Figure 19-10 on page 224](#).

RXRDY behavior in Slave mode can be seen in [Figure 19-25 on page 239](#), [Figure 19-28 on page 242](#), [Figure 19-29 on page 243](#) and [Figure 19-30 on page 243](#).

- **TXCOMP: Transmission Completed (automatically set / reset)**

TXCOMP used in Master mode:

0 = During the length of the current frame.

1 = When both holding and shifter registers are empty and STOP condition has been sent.

TXCOMP behavior in Master mode can be seen in [Figure 19-8 on page 223](#) and in [Figure 19-10 on page 224](#).

TXCOMP used in Slave mode:

0 = As soon as a Start is detected.

1 = After a Stop or a Repeated Start + an address different from SADR is detected.

TXCOMP behavior in Slave mode can be seen in [Figure 19-27 on page 241](#), [Figure 19-28 on page 242](#), [Figure 19-29 on page 243](#) and [Figure 19-30 on page 243](#).

19.14.7 Interrupt Enable Register

Name: IER

Access: Write-only

Offset: 0x24

Reset Value: 0x00000000

| | | | | | | | |
|----|------|------|-------|--------|--------|--------|--------|
| 31 | 30 | 29 | 28 | 27 | 26 | 25 | 24 |
| - | - | - | - | - | - | - | - |
| 23 | 22 | 21 | 20 | 19 | 18 | 17 | 16 |
| - | - | - | - | - | - | - | - |
| 15 | 14 | 13 | 12 | 11 | 10 | 9 | 8 |
| - | - | - | - | EOSACC | SCL_WS | ARBLST | NACK |
| 7 | 6 | 5 | 4 | 3 | 2 | 1 | 0 |
| - | OVRE | GACC | SVACC | - | TXRDY | RXRDY | TXCOMP |

Writing a zero to a bit in this register has no effect.

Writing a one to a bit in this register will set the corresponding bit in IMR.

19.14.8 Interrupt Disable Register

Name: IDR

Access: Write-only

Offset: 0x28

Reset Value: 0x00000000

| | | | | | | | |
|----|------|------|-------|--------|--------|--------|--------|
| 31 | 30 | 29 | 28 | 27 | 26 | 25 | 24 |
| - | - | - | - | - | - | - | - |
| 23 | 22 | 21 | 20 | 19 | 18 | 17 | 16 |
| - | - | - | - | - | - | - | - |
| 15 | 14 | 13 | 12 | 11 | 10 | 9 | 8 |
| - | - | - | - | EOSACC | SCL_WS | ARBLST | NACK |
| 7 | 6 | 5 | 4 | 3 | 2 | 1 | 0 |
| - | OVRE | GACC | SVACC | - | TXRDY | RXRDY | TXCOMP |

Writing a zero to a bit in this register has no effect.

Writing a one to a bit in this register will clear the corresponding bit in IMR.

19.14.9 Interrupt Mask Register

Name: IMR

Access: Read-only

Offset: 0x2C

Reset Value: 0x00000000

| | | | | | | | |
|----|------|------|-------|--------|--------|--------|--------|
| 31 | 30 | 29 | 28 | 27 | 26 | 25 | 24 |
| – | – | – | – | – | – | – | – |
| 23 | 22 | 21 | 20 | 19 | 18 | 17 | 16 |
| – | – | – | – | – | – | – | – |
| 15 | 14 | 13 | 12 | 11 | 10 | 9 | 8 |
| – | – | – | – | EOSACC | SCL_WS | ARBLST | NACK |
| 7 | 6 | 5 | 4 | 3 | 2 | 1 | 0 |
| – | OVRE | GACC | SVACC | – | TXRDY | RXRDY | TXCOMP |

0: The corresponding interrupt is disabled.

1: The corresponding interrupt is enabled.

A bit in this register is cleared when the corresponding bit in IDR is written to one.

A bit in this register is set when the corresponding bit in IER is written to one.

19.14.10 Receive Holding Register

Name: RHR

Access: Read-only

Offset: 0x30

Reset Value: 0x00000000

| | | | | | | | |
|--------|----|----|----|----|----|----|----|
| 31 | 30 | 29 | 28 | 27 | 26 | 25 | 24 |
| - | - | - | - | - | - | - | - |
| 23 | 22 | 21 | 20 | 19 | 18 | 17 | 16 |
| - | - | - | - | - | - | - | - |
| 15 | 14 | 13 | 12 | 11 | 10 | 9 | 8 |
| - | - | - | - | - | - | - | - |
| 7 | 6 | 5 | 4 | 3 | 2 | 1 | 0 |
| RXDATA | | | | | | | |

- **RXDATA: Master or Slave Receive Holding Data**

19.14.11 Transmit Holding Register

Name: THR

Access: Read-write

Offset: 0x34

Reset Value: 0x00000000

| | | | | | | | |
|--------|----|----|----|----|----|----|----|
| 31 | 30 | 29 | 28 | 27 | 26 | 25 | 24 |
| - | - | - | - | - | - | - | - |
| 23 | 22 | 21 | 20 | 19 | 18 | 17 | 16 |
| - | - | - | - | - | - | - | - |
| 15 | 14 | 13 | 12 | 11 | 10 | 9 | 8 |
| - | - | - | - | - | - | - | - |
| 7 | 6 | 5 | 4 | 3 | 2 | 1 | 0 |
| TXDATA | | | | | | | |

- **TXDATA: Master or Slave Transmit Holding Data**

20. Synchronous Serial Controller (SSC)

Rev: 3.1.0.2

20.1 Features

- Provides serial synchronous communication links used in audio and telecom applications
- Independent receiver and transmitter, common clock divider
- Interfaced with two Peripheral DMA Controller channels to reduce processor overhead
- Configurable frame sync and data length
- Receiver and transmitter can be configured to start automatically or on detection of different events on the frame sync signal
- Receiver and transmitter include a data signal, a clock signal and a frame synchronization signal

20.2 Overview

The Synchronous Serial Controller (SSC) provides a synchronous communication link with external devices. It supports many serial synchronous communication protocols generally used in audio and telecom applications such as I2S, Short Frame Sync, Long Frame Sync, etc.

The SSC consists of a receiver, a transmitter, and a common clock divider. Both the receiver and the transmitter interface with three signals:

- the TX_DATA/RX_DATA signal for data
- the TX_CLOCK/RX_CLOCK signal for the clock
- the TX_FRAME_SYNC/RX_FRAME_SYNC signal for the frame synchronization

The transfers can be programmed to start automatically or on different events detected on the Frame Sync signal.

The SSC's high-level of programmability and its two dedicated Peripheral DMA Controller channels of up to 32 bits permit a continuous high bit rate data transfer without processor intervention.

Featuring connection to two Peripheral DMA Controller channels, the SSC permits interfacing with low processor overhead to the following:

- CODEC's in master or slave mode
- DAC through dedicated serial interface, particularly I2S
- Magnetic card reader

20.3 Block Diagram

Figure 20-1. SSC Block Diagram

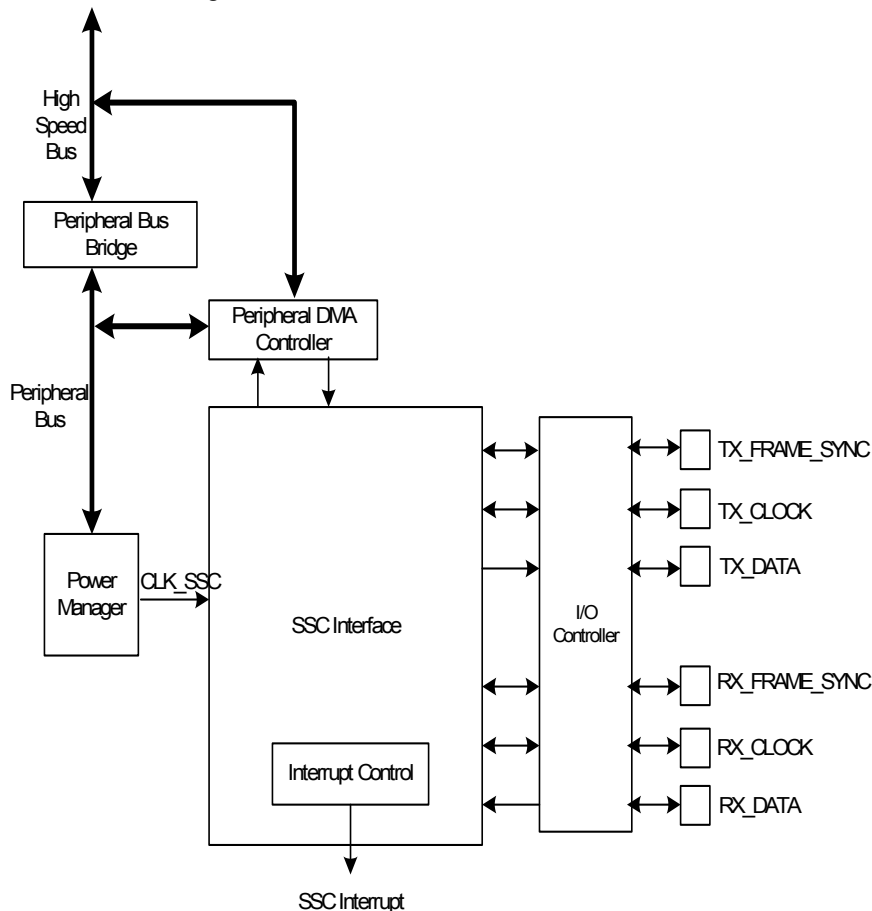

20.4 Application Block Diagram

Figure 20-2. SSC Application Block Diagram

| | | | |
|-------------------|------------------|----------------------|------------------|
| OS or RTOS Driver | Power Management | Interrupt Management | Test Management |
| SSC | | | |
| Serial AUDIO | Codec | Time Slot Management | Frame Management |
| | | | Line Interface |

20.5 I/O Lines Description

Table 20-1. I/O Lines Description

| Pin Name | Pin Description | Type |
|---------------|---------------------------|--------------|
| RX_FRAME_SYNC | Receiver Frame Synchro | Input/Output |
| RX_CLOCK | Receiver Clock | Input/Output |
| RX_DATA | Receiver Data | Input |
| TX_FRAME_SYNC | Transmitter Frame Synchro | Input/Output |
| TX_CLOCK | Transmitter Clock | Input/Output |
| TX_DATA | Transmitter Data | Output |

20.6 Product Dependencies

In order to use this module, other parts of the system must be configured correctly, as described below.

20.6.1 I/O Lines

The pins used for interfacing the compliant external devices may be multiplexed with I/O lines.

Before using the SSC receiver, the I/O Controller must be configured to dedicate the SSC receiver I/O lines to the SSC peripheral mode.

Before using the SSC transmitter, the I/O Controller must be configured to dedicate the SSC transmitter I/O lines to the SSC peripheral mode.

20.6.2 Clocks

The clock for the SSC bus interface (CLK_SSC) is generated by the Power Manager. This clock is enabled at reset, and can be disabled in the Power Manager. It is recommended to disable the SSC before disabling the clock, to avoid freezing the SSC in an undefined state.

20.6.3 Interrupts

The SSC interrupt request line is connected to the interrupt controller. Using the SSC interrupt requires the interrupt controller to be programmed first.

20.7 Functional Description

This chapter contains the functional description of the following: SSC functional block, clock management, data framing format, start, transmitter, receiver, and frame sync.

The receiver and the transmitter operate separately. However, they can work synchronously by programming the receiver to use the transmit clock and/or to start a data transfer when transmission starts. Alternatively, this can be done by programming the transmitter to use the receive clock and/or to start a data transfer when reception starts. The transmitter and the receiver can be programmed to operate with the clock signals provided on either the TX_CLOCK or RX_CLOCK pins. This allows the SSC to support many slave-mode data transfers. The maximum clock speed allowed on the TX_CLOCK and RX_CLOCK pins is CLK_SSC divided by two.

Figure 20-3. SSC Functional Block Diagram

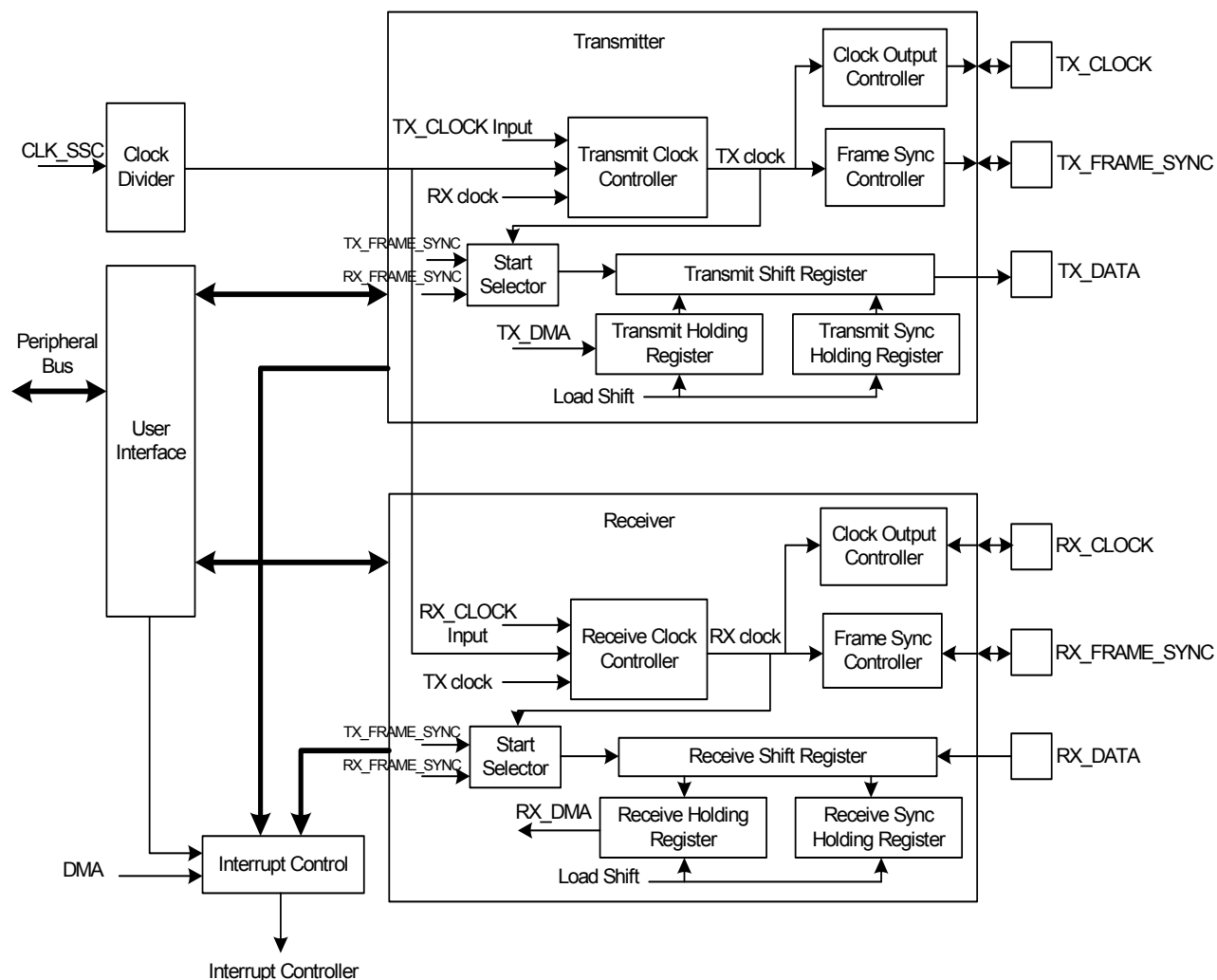

20.7.1 Clock Management

The transmitter clock can be generated by:

- an external clock received on the TX_CLOCK pin
- the receiver clock
- the internal clock divider

The receiver clock can be generated by:

- an external clock received on the RX_CLOCK pin
- the transmitter clock
- the internal clock divider

Furthermore, the transmitter block can generate an external clock on the TX_CLOCK pin, and the receiver block can generate an external clock on the RX_CLOCK pin.

This allows the SSC to support many Master and Slave Mode data transfers.

20.7.1.1 Clock divider

Figure 20-4. Divided Clock Block Diagram

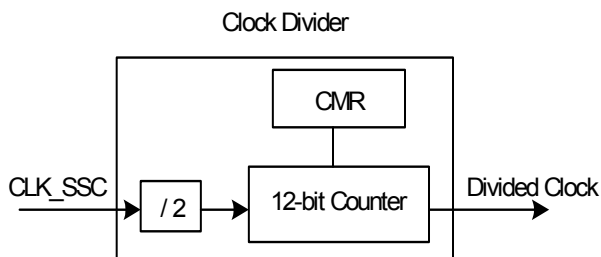

The peripheral clock divider is determined by the 12-bit Clock Divider field (its maximal value is 4095) in the Clock Mode Register (CMR.DIV), allowing a peripheral clock division by up to 8190. The divided clock is provided to both the receiver and transmitter. When this field is written to zero, the clock divider is not used and remains inactive.

When CMR.DIV is written to a value equal to or greater than one, the divided clock has a frequency of CLK_SSC divided by two times CMR.DIV. Each level of the divided clock has a duration of the peripheral clock multiplied by CMR.DIV. This ensures a 50% duty cycle for the divided clock regardless of whether the CMR.DIV value is even or odd.

Figure 20-5. Divided Clock Generation

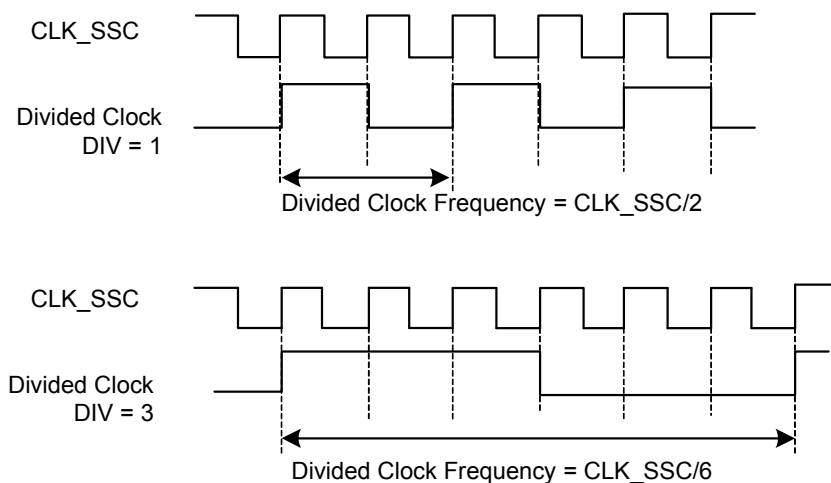

Table 20-2. Range of Clock Divider

| Maximum | Minimum |
|-------------|----------------|
| CLK_SSC / 2 | CLK_SSC / 8190 |

20.7.1.2 Transmitter clock management

The transmitter clock is generated from the receiver clock, the divider clock, or an external clock scanned on the TX_CLOCK pin. The transmitter clock is selected by writing to the Transmit Clock Selection field in the Transmit Clock Mode Register (TCMR.CKS). The transmit clock can

be inverted independently by writing a one to the Transmit Clock Inversion bit in TCMR (TCMR.CKI).

The transmitter can also drive the TX_CLOCK pin continuously or be limited to the actual data transfer, depending on the Transmit Clock Output Mode Selection field in the TCMR register (TCMR.CKO). The TCMR.CKI bit has no effect on the clock outputs.

Writing 0b10 to the TCMR.CKS field to select TX_CLOCK pin and 0b001 to the TCMR.CKO field to select Continuous Transmit Clock can lead to unpredictable results.

Figure 20-6. Transmitter Clock Management

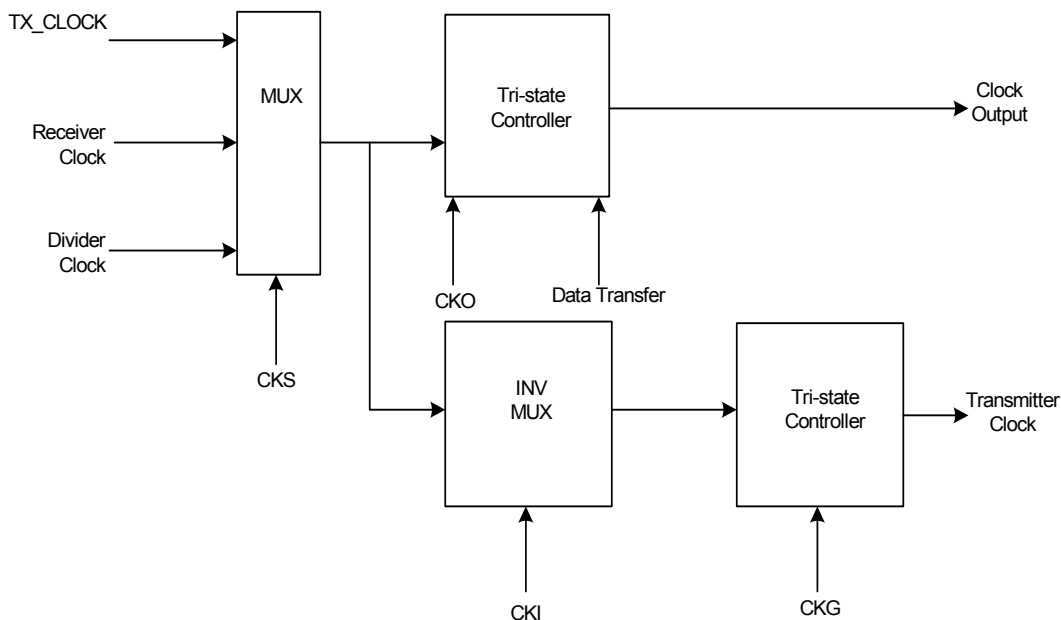

20.7.1.3 Receiver clock management

The receiver clock is generated from the transmitter clock, the divider clock, or an external clock scanned on the RX_CLOCK pin. The receive clock is selected by writing to the Receive Clock Selection field in the Receive Clock Mode Register (RCMR.CKS). The receive clock can be inverted independently by writing a one to the Receive Clock Inversion bit in RCMR (RCMR.CKI).

The receiver can also drive the RX_CLOCK pin continuously or be limited to the actual data transfer, depending on the Receive Clock Output Mode Selection field in the RCMR register (RCMR.CKO). The RCMR.CKI bit has no effect on the clock outputs.

Writing 0b10 to the RCMR.CKS field to select RX_CLOCK pin and 0b001 to the RCMR.CKO field to select Continuous Receive Clock can lead to unpredictable results.

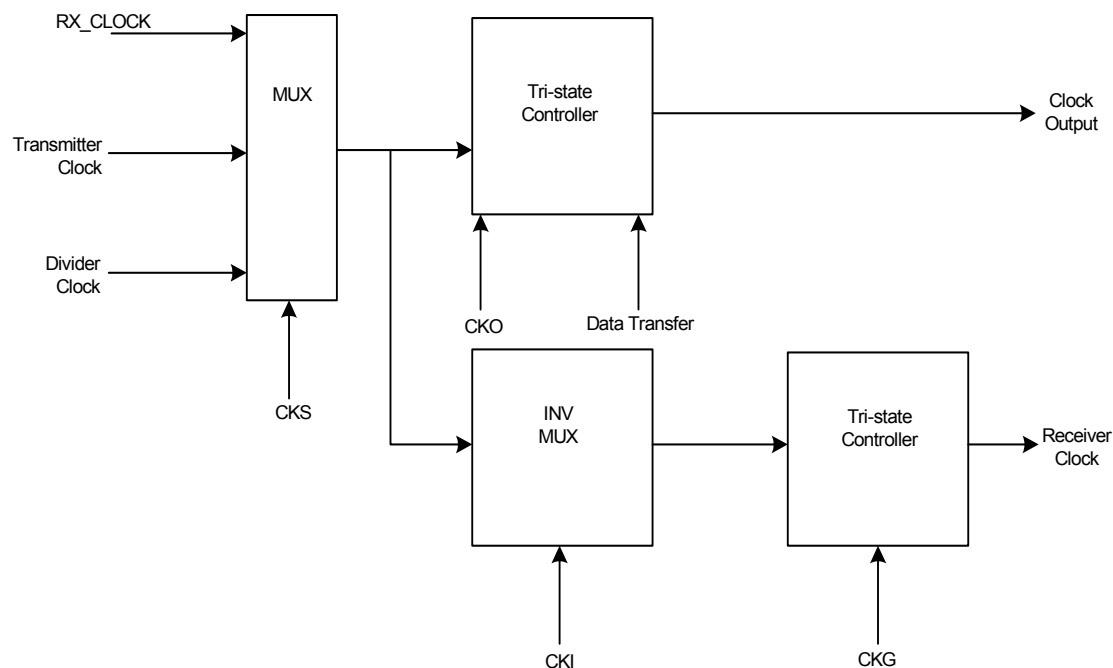
Figure 20-7. Receiver Clock Management

20.7.1.4 Serial clock ratio considerations

The transmitter and the receiver can be programmed to operate with the clock signals provided on either the TX_CLOCK or RX_CLOCK pins. This allows the SSC to support many slave-mode data transfers. In this case, the maximum clock speed allowed on the RX_CLOCK pin is:

- CLK_SSC divided by two if RX_FRAME_SYNC is input.
- CLK_SSC divided by three if RX_FRAME_SYNC is output.

In addition, the maximum clock speed allowed on the TX_CLOCK pin is:

- CLK_SSC divided by six if TX_FRAME_SYNC is input.
- CLK_SSC divided by two if TX_FRAME_SYNC is output.

20.7.2 Transmitter Operations

A transmitted frame is triggered by a start event and can be followed by synchronization data before data transmission.

The start event is configured by writing to the TCMR register. See [Section 20.7.4](#).

The frame synchronization is configured by writing to the Transmit Frame Mode Register (TFMR). See [Section 20.7.5](#).

To transmit data, the transmitter uses a shift register clocked by the transmitter clock signal and the start mode selected in the TCMR register. Data is written by the user to the Transmit Holding Register (THR) then transferred to the shift register according to the data format selected.

When both the THR and the transmit shift registers are empty, the Transmit Empty bit is set in the Status Register (SR.TXEMPTY). When the THR register is transferred in the transmit shift register, the Transmit Ready bit is set in the SR register (SR.TXREADY) and additional data can be loaded in the THR register.

Figure 20-8. Transmitter Block Diagram

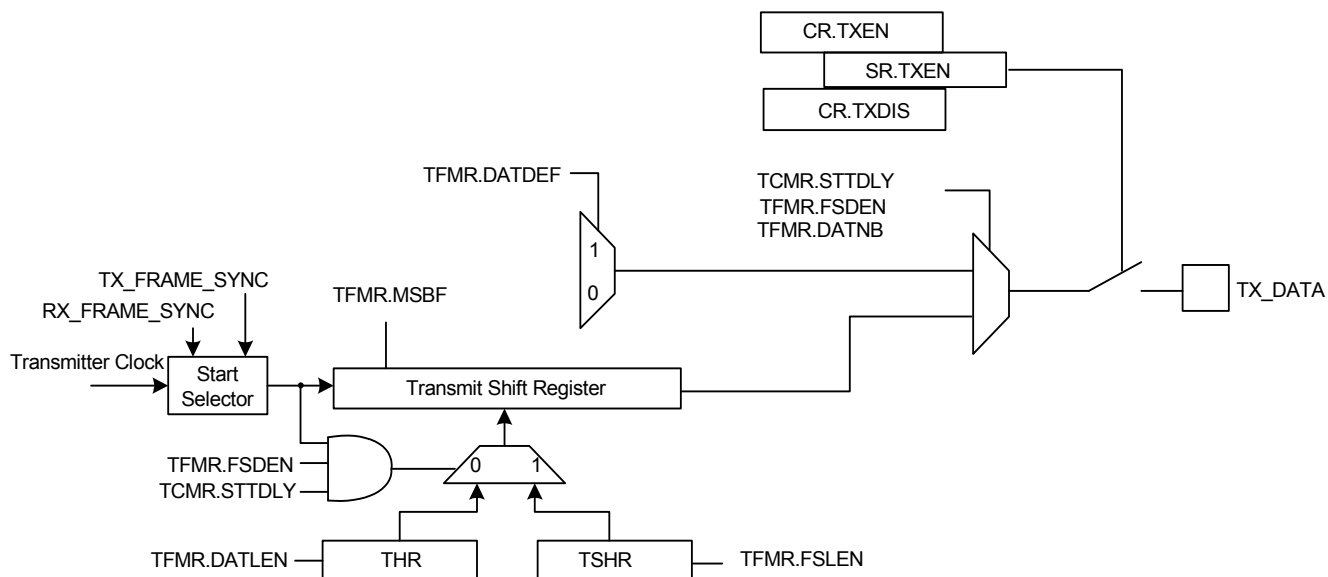

20.7.3 Receiver Operations

A received frame is triggered by a start event and can be followed by synchronization data before data transmission.

The start event is configured by writing to the RCMR register. See [Section 20.7.4](#).

The frame synchronization is configured by writing to the Receive Frame Mode Register (RFMR). See [Section 20.7.5](#).

The receiver uses a shift register clocked by the receiver clock signal and the start mode selected in the RCMR register. The data is transferred from the shift register depending on the data format selected.

When the receiver shift register is full, the SSC transfers this data in the Receive Holding Register (RHR), the Receive Ready bit is set in the SR register (SR.RXREADY) and the data can be read in the RHR register. If another transfer occurs before a read of the RHR register, the Receive Overrun bit is set in the SR register (SR.OVRUN) and the receiver shift register is transferred to the RHR register.

Figure 20-9. Receiver Block Diagram

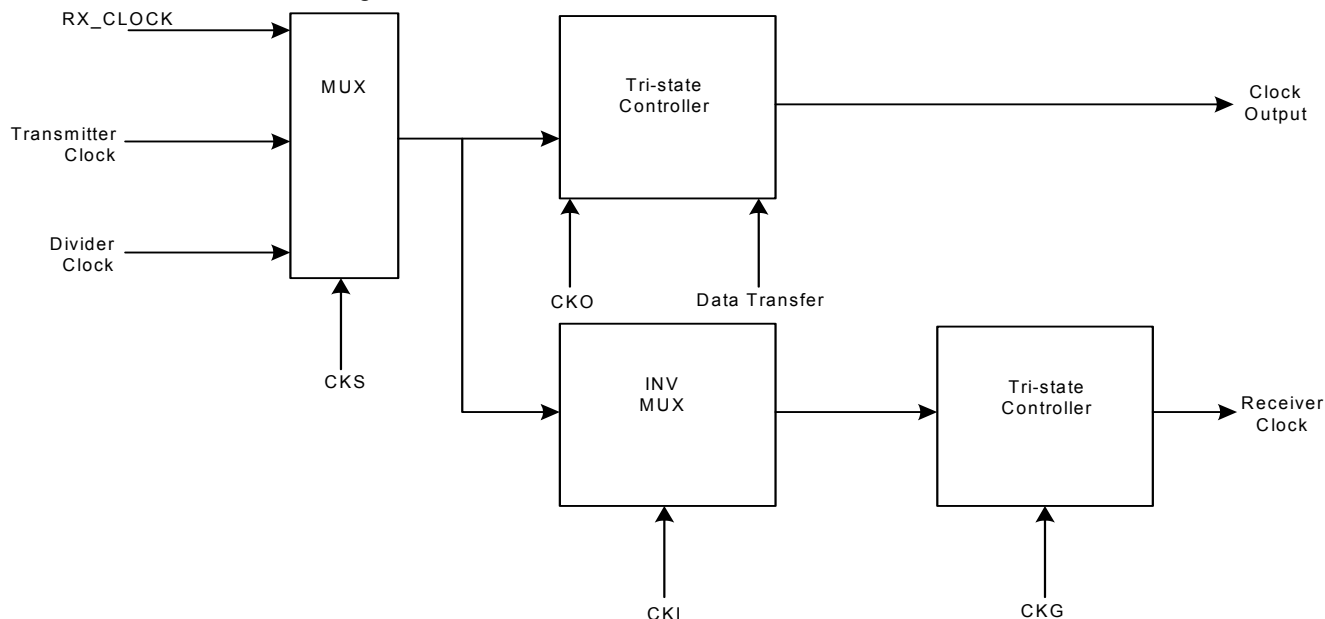

20.7.4 Start

The transmitter and receiver can both be programmed to start their operations when an event occurs, respectively in the Transmit Start Selection field of the TCMR register (TCMR.START) and in the Receive Start Selection field of the RCMR register (RCMR.START).

Under the following conditions the start event is independently programmable:

- Continuous: in this case, the transmission starts as soon as a word is written to the THR register and the reception starts as soon as the receiver is enabled
- Synchronously with the transmitter/receiver
- On detection of a falling/rising edge on TX_FRAME_SYNC/RX_FRAME_SYNC
- On detection of a low/high level on TX_FRAME_SYNC/RX_FRAME_SYNC
- On detection of a level change or an edge on TX_FRAME_SYNC/RX_FRAME_SYNC

A start can be programmed in the same manner on either side of the Transmit/Receive Clock Mode Register (TCMR/RCMR). Thus, the start could be on TX_FRAME_SYNC (transmit) or RX_FRAME_SYNC (receive).

Moreover, the receiver can start when data is detected in the bit stream with the compare functions. See [Section 20.7.6](#) for more details on receive compare modes.

Detection on TX_FRAME_SYNC input/output is done by the Transmit Frame Sync Output Selection field in the TFMR register (TFMR.FSOS). Similarly, detection on RX_FRAME_SYNC input/output is done by the Receive Frame Output Sync Selection field in the RFMR register (RFMR.FSOS).

Figure 20-10. Transmit Start Mode

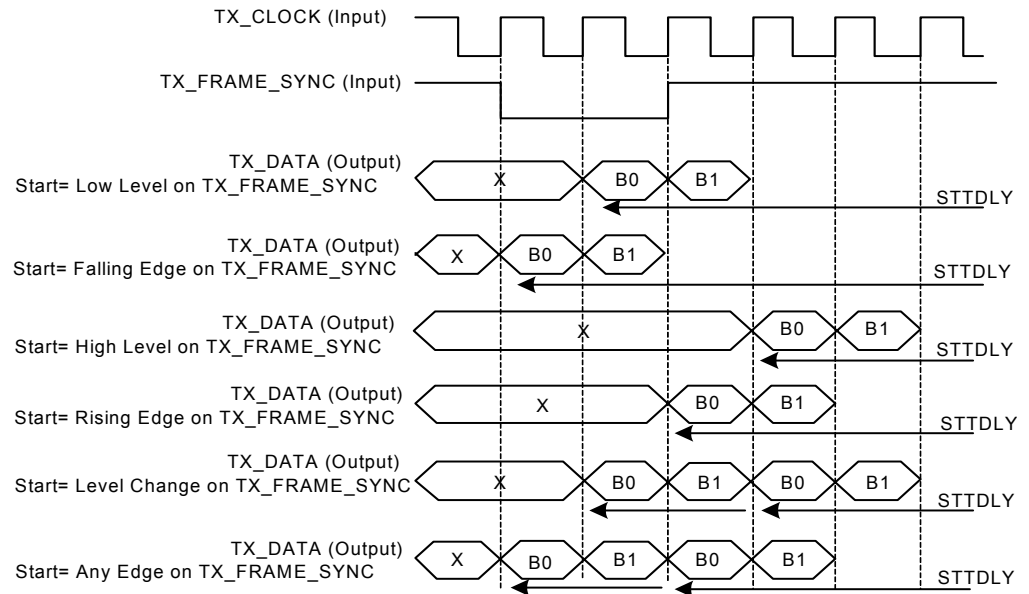
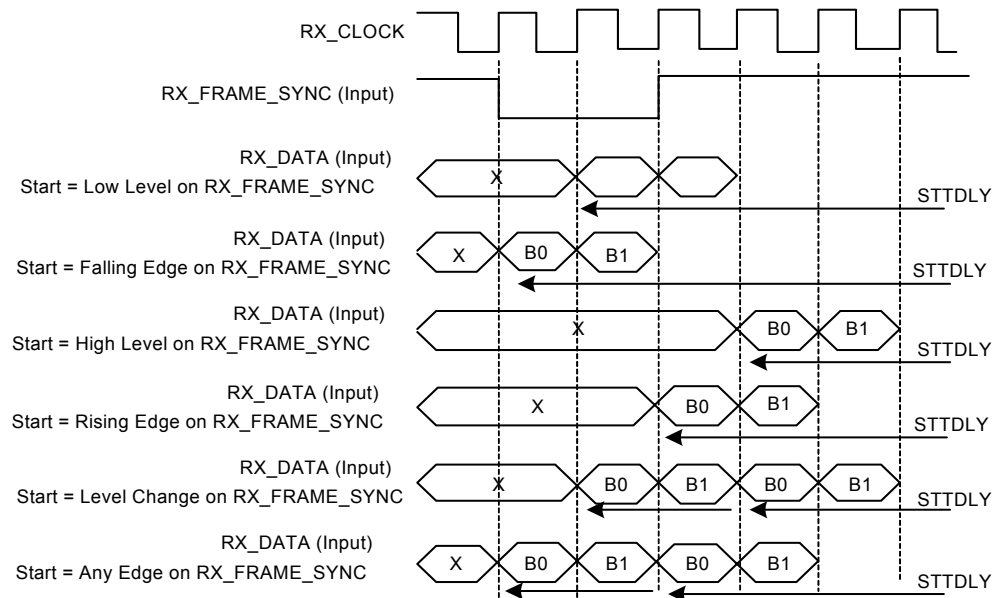

Figure 20-11. Receive Pulse/Edge Start Modes



20.7.5 Frame Sync

The transmitter and receiver frame synchro pins, TX_FRAME_SYNC and RX_FRAME_SYNC, can be programmed to generate different kinds of frame synchronization signals. The RFMR.FSOS and TFMR.FSOS fields are used to select the required waveform.

- Programmable low or high levels during data transfer are supported.
- Programmable high levels before the start of data transfers or toggling are also supported.

If a pulse waveform is selected, in reception, the Receive Frame Sync Length High Part and the Receive Frame Sync Length fields in the RFMR register (RFMR.FSLENHI and RFMR.FSLEN) define the length of the pulse, from 1 bit time up to 256 bit time.

$$\text{Reception Pulse Length} = ((16 \times FSLENHI) + FSLEN + 1) \text{ receive clock periods}$$

Similarly, in transmission, the Transmit Frame Sync Length High Part and the Transmit Frame Sync Length fields in the TFMR register (TFMR.FSLENHI and TFMR.FSLEN) define the length of the pulse, from 1 bit up to 256 bit time.

$$\text{Transmission Pulse Length} = ((16 \times FSLENHI) + FSLEN + 1) \text{ transmit clock periods}$$

The periodicity of the RX_FRAME_SYNC and TX_FRAME_SYNC pulse outputs can be configured respectively through the Receive Period Divider Selection field in the RCMR register (RCMR.PERIOD) and the Transmit Period Divider Selection field in the TCMR register (TCMR.PERIOD).

20.7.5.1 Frame sync data

Frame Sync Data transmits or receives a specific tag during the Frame Sync signal.

During the Frame Sync signal, the receiver can sample the RX_DATA line and store the data in the Receive Sync Holding Register (RSHR) and the transmitter can transfer the Transmit Sync Holding Register (TSHR) in the shifter register.

The data length to be sampled in reception during the Frame Sync signal shall be written to the RFMR.FSLENHI and RFMR.FSLEN fields.

The data length to be shifted out in transmission during the Frame Sync signal shall be written to the TFMR.FSLENHI and TFMR.FSLEN fields.

Concerning the Receive Frame Sync Data operation, if the Frame Sync Length is equal to or lower than the delay between the start event and the actual data reception, the data sampling operation is performed in the RSHR through the receive shift register.

The Transmit Frame Sync operation is performed by the transmitter only if the Frame Sync Data Enable bit in TFMR register (TFMR.FSDEN) is written to one. If the Frame Sync length is equal to or lower than the delay between the start event and the actual data transmission, the normal transmission has priority and the data contained in the TSHR is transferred in the transmit register, then shifted out.

20.7.5.2 Frame sync edge detection

The Frame Sync Edge detection is configured by writing to the Frame Sync Edge Detection bit in the RFMR/TFMR registers (RFMR.FSEDGE and TFMR.FSEDGE). This sets the Receive Sync

and Transmit Sync bits in the SR register (SR.RXSYN and SR.TXSYN) on frame synchro edge detection (signals RX_FRAME_SYNC/TX_FRAME_SYNC).

20.7.6 Receive Compare Modes

Figure 20-12. Receive Compare Modes

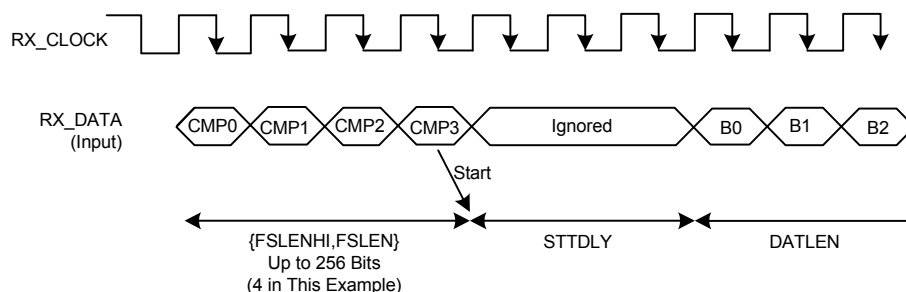

20.7.6.1 Compare functions

Compare 0 can be one start event of the receiver. In this case, the receiver compares at each new sample the last {RFMR.FSLENHI, RFMR.FSLEN} bits received to the {RFMR.FSLENHI, RFMR.FSLEN} lower bits of the data contained in the Receive Compare 0 Register (RC0R). When this start event is selected, the user can program the receiver to start a new data transfer either by writing a new Compare 0, or by receiving continuously until Compare 1 occurs. This selection is done with the Receive Stop Selection bit in the RCMR register (RCMR.STOP).

20.7.7 Data Framing Format

The data framing format of both the transmitter and the receiver are programmable through the TFMR, TCMR, RFMR, and RCMR registers. In either case, the user can independently select:

- the event that starts the data transfer (RCMR.START and TCMR.START)
- the delay in number of bit periods between the start event and the first data bit (RCMR.STTDLY and TCMR.STTDLY)
- the length of the data (RFMR.DATLEN and TFMR.DATLEN)
- the number of data to be transferred for each start event (RFMR.DATNB and TFMR.DATLEN)
- the length of synchronization transferred for each start event (RFMR.FSLENHI, RFMR.FSLEN, TFMR.FSLENHI, and TFMR.FSLEN)
- the bit sense: most or lowest significant bit first (RFMR.MSBF and TFMR.MSBF)

Additionally, the transmitter can be used to transfer synchronization and select the level driven on the TX_DATA pin while not in data transfer operation. This is done respectively by writing to the Frame Sync Data Enable and the Data Default Value bits in the TFMR register (TFMR.FSDEN and TFMR.DATDEF).

Table 20-3. Data Framing Format Registers

| Transmitter | Receiver | Bit/Field | Length | Comment |
|-------------|----------|-----------|-----------|------------------------------|
| TCMR | RCMR | PERIOD | Up to 512 | Frame size |
| TCMR | RCMR | START | | Start selection |
| TCMR | RCMR | STTDLY | Up to 255 | Size of transmit start delay |

Table 20-3. Data Framing Format Registers

| Transmitter | Receiver | Bit/Field | Length | Comment |
|-------------|----------|-----------------|-----------|--------------------------------------|
| TFMR | RFMR | DATNB | Up to 16 | Number of words transmitted in frame |
| TFMR | RFMR | DATLEN | Up to 32 | Size of word |
| TFMR | RFMR | {FSLENHI,FSLEN} | Up to 256 | Size of Synchro data register |
| TFMR | RFMR | MSBF | | Most significant bit first |
| TFMR | | FSDEN | | Enable send TSHR |
| TFMR | | DATDEF | | Data default value ended |

Figure 20-13. Transmit and Receive Frame Format in Edge/Pulse Start Modes

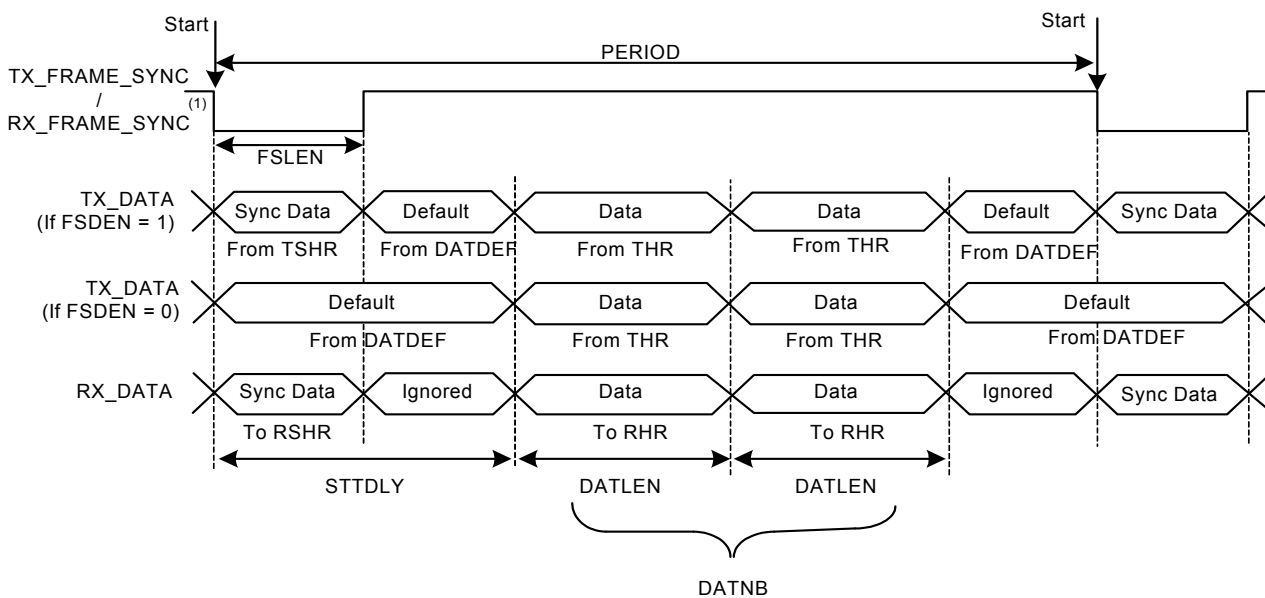

Note: Example of input on falling edge of TX_FRAME_SYNC/RX_FRAME_SYNC.

Figure 20-14. Transmit Frame Format in Continuous Mode

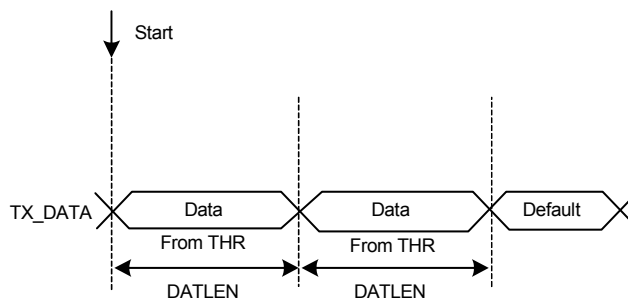

Start: 1. TXEMPTY set to one
2. Write into the THR

Note: STTDLY is written to zero. In this example, THR is loaded twice. FSDEN value has no effect on the transmission. SyncData cannot be output in continuous mode.

Figure 20-15. Receive Frame Format in Continuous Mode

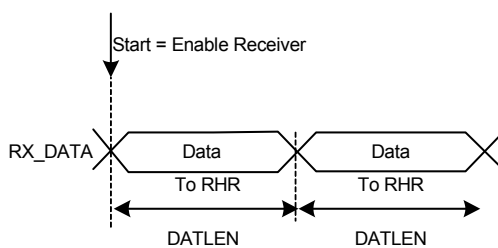

Note: STTDLY is written to zero.

20.7.8 Loop Mode

The receiver can be programmed to receive transmissions from the transmitter. This is done by writing a one to the Loop Mode bit in RFMR register (RFMR.LOOP). In this case, RX_DATA is connected to TX_DATA, RX_FRAME_SYNC is connected to TX_FRAME_SYNC and RX_CLOCK is connected to TX_CLOCK.

20.7.9 Interrupt

Most bits in the SR register have a corresponding bit in interrupt management registers.

The SSC can be programmed to generate an interrupt when it detects an event. The interrupt is controlled by writing to the Interrupt Enable Register (IER) and Interrupt Disable Register (IDR). These registers enable and disable, respectively, the corresponding interrupt by setting and clearing the corresponding bit in the Interrupt Mask Register (IMR), which controls the generation of interrupts by asserting the SSC interrupt line connected to the interrupt controller.

Figure 20-16. Interrupt Block Diagram

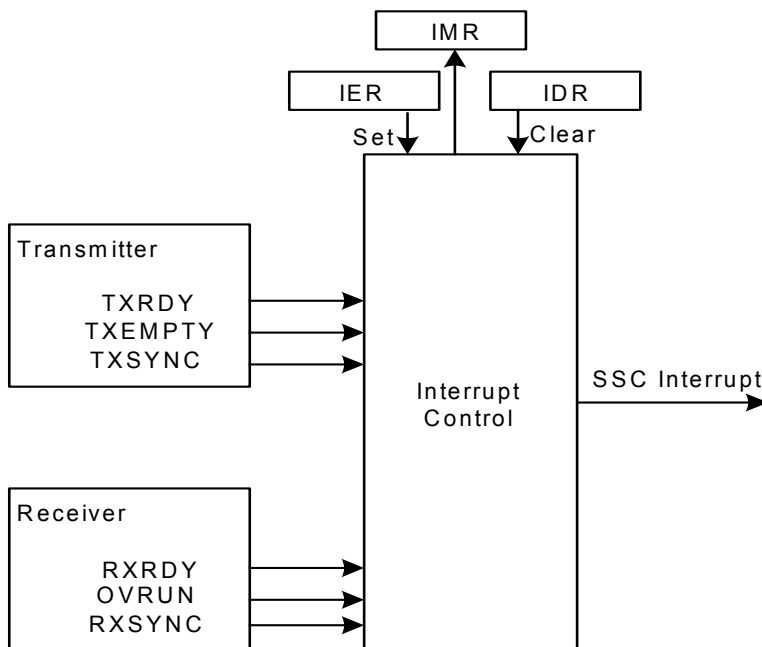

20.8 SSC Application Examples

The SSC can support several serial communication modes used in audio or high speed serial links. Some standard applications are shown in the following figures. All serial link applications supported by the SSC are not listed here.

Figure 20-17. Audio Application Block Diagram

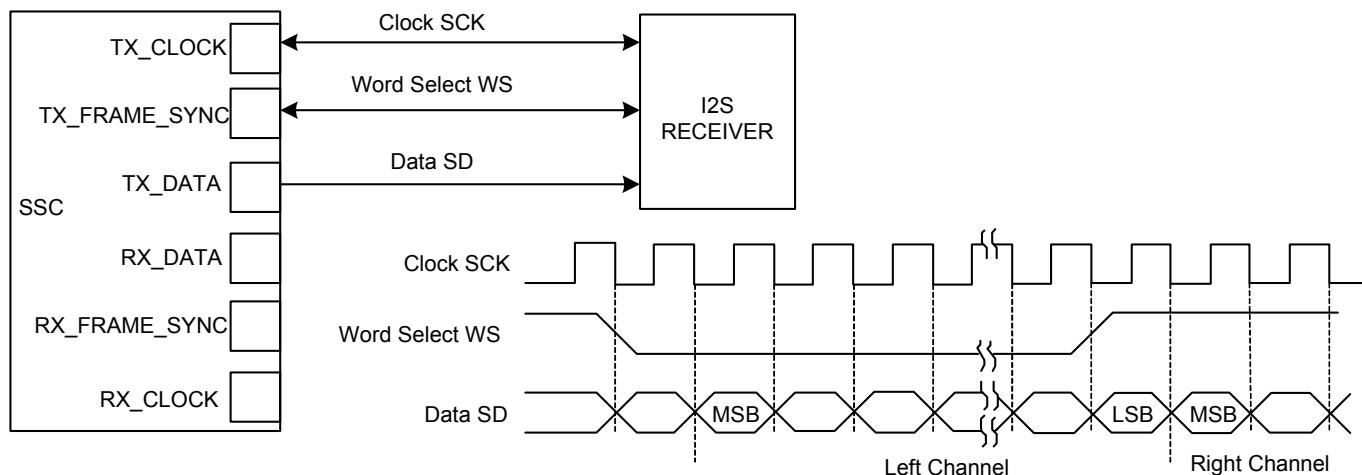

Figure 20-18. Codec Application Block Diagram

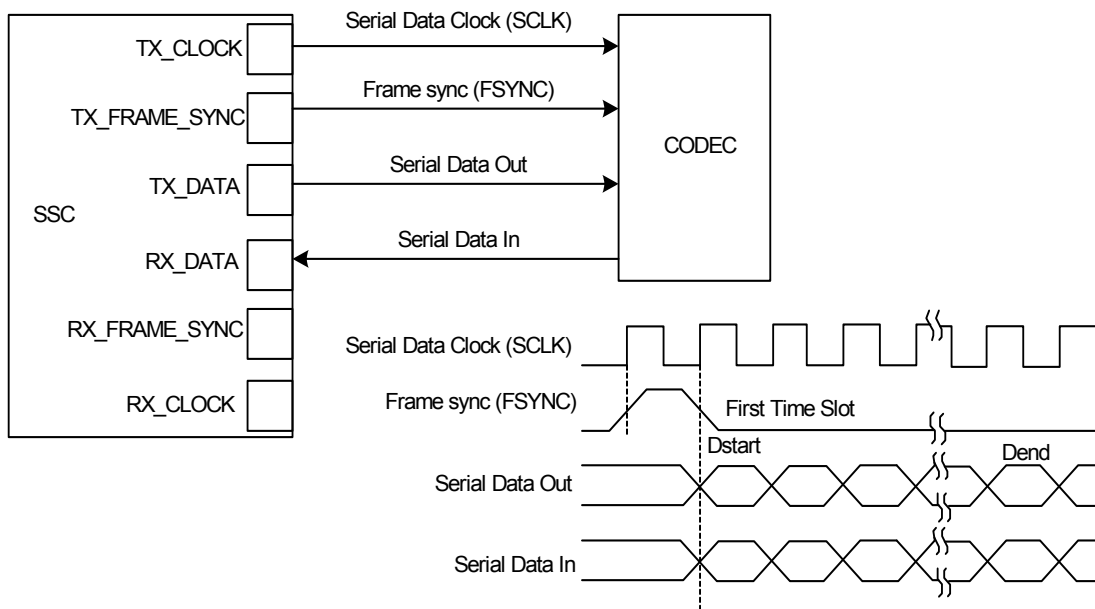
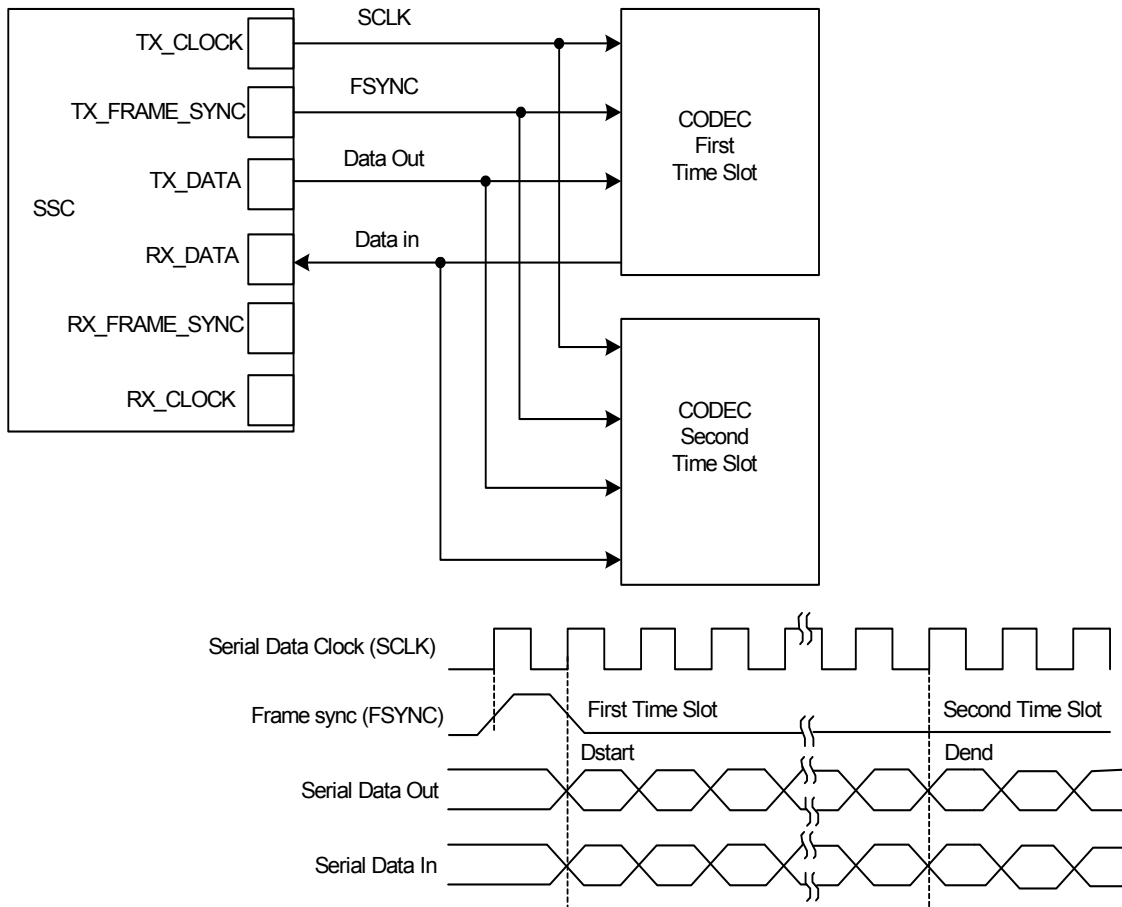

Figure 20-19. Time Slot Application Block Diagram



20.9 User Interface

Table 20-4. SSC Register Memory Map

| Offset | Register | Register Name | Access | Reset |
|--------|---|---------------|------------|------------|
| 0x00 | Control Register | CR | Write-only | 0x00000000 |
| 0x04 | Clock Mode Register | CMR | Read/Write | 0x00000000 |
| 0x10 | Receive Clock Mode Register | RCMR | Read/Write | 0x00000000 |
| 0x14 | Receive Frame Mode Register | RFMR | Read/Write | 0x00000000 |
| 0x18 | Transmit Clock Mode Register | TCMR | Read/Write | 0x00000000 |
| 0x1C | Transmit Frame Mode Register | TFMR | Read/Write | 0x00000000 |
| 0x20 | Receive Holding Register | RHR | Read-only | 0x00000000 |
| 0x24 | Transmit Holding Register | THR | Write-only | 0x00000000 |
| 0x30 | Receive Synchronization Holding Register | RSHR | Read-only | 0x00000000 |
| 0x34 | Transmit Synchronization Holding Register | TSHR | Read/Write | 0x00000000 |
| 0x38 | Receive Compare 0 Register | RC0R | Read/Write | 0x00000000 |
| 0x3C | Receive Compare 1 Register | RC1R | Read/Write | 0x00000000 |
| 0x40 | Status Register | SR | Read-only | 0x000000CC |
| 0x44 | Interrupt Enable Register | IER | Write-only | 0x00000000 |
| 0x48 | Interrupt Disable Register | IDR | Write-only | 0x00000000 |
| 0x4C | Interrupt Mask Register | IMR | Read-only | 0x00000000 |

20.9.1 Control Register

Name: CR
Access Type: Write-only
Offset: 0x00
Reset value: 0x00000000

| | | | | | | | |
|-------|----|----|----|----|----|-------|------|
| 31 | 30 | 29 | 28 | 27 | 26 | 25 | 24 |
| - | - | - | - | - | - | - | - |
| 23 | 22 | 21 | 20 | 19 | 18 | 17 | 16 |
| - | - | - | - | - | - | - | - |
| 15 | 14 | 13 | 12 | 11 | 10 | 9 | 8 |
| SWRST | - | - | - | - | - | TXDIS | TXEN |
| 7 | 6 | 5 | 4 | 3 | 2 | 1 | 0 |
| - | - | - | - | - | - | RXDIS | RXEN |

- SWRST: Software Reset**
 - 1: Writing a one to this bit will perform a software reset. This software reset has priority on any other bit in CR.
 - 0: Writing a zero to this bit has no effect.
- TXDIS: Transmit Disable**
 - 1: Writing a one to this bit will disable the transmission. If a character is currently being transmitted, the disable occurs at the end of the current character transmission.
 - 0: Writing a zero to this bit has no effect.
- TXEN: Transmit Enable**
 - 1: Writing a one to this bit will enable the transmission if the TXDIS bit is not written to one.
 - 0: Writing a zero to this bit has no effect.
- RXDIS: Receive Disable**
 - 1: Writing a one to this bit will disable the reception. If a character is currently being received, the disable occurs at the end of current character reception.
 - 0: Writing a zero to this bit has no effect.
- RXEN: Receive Enable**
 - 1: Writing a one to this bit will enables the reception if the RXDIS bit is not written to one.
 - 0: Writing a zero to this bit has no effect.

20.9.2 Clock Mode Register

Name: CMR
Access Type: Read/Write
Offset: 0x04
Reset value: 0x00000000

| | | | | | | | |
|----------|----|----|----|-----------|----|----|----|
| 31 | 30 | 29 | 28 | 27 | 26 | 25 | 24 |
| - | - | - | - | - | - | - | - |
| 23 | 22 | 21 | 20 | 19 | 18 | 17 | 16 |
| - | - | - | - | - | - | - | - |
| 15 | 14 | 13 | 12 | 11 | 10 | 9 | 8 |
| - | - | - | - | DIV[11:8] | | | |
| 7 | 6 | 5 | 4 | 3 | 2 | 1 | 0 |
| DIV[7:0] | | | | | | | |

- **DIV[11:0]: Clock Divider**

The divided clock equals the CLK_SSC divided by two times DIV. The maximum bit rate is CLK_SSC/2. The minimum bit rate is CLK_SSC/(2 x 4095) = CLK_SSC/8190.

The clock divider is not active when DIV equals zero.

$$\text{Divided Clock} = \text{CLK_SSC} / (\text{DIV} \times 2)$$

20.9.3 Receive Clock Mode Register

Name: RCMR
Access Type: Read/Write
Offset: 0x10
Reset value: 0x00000000

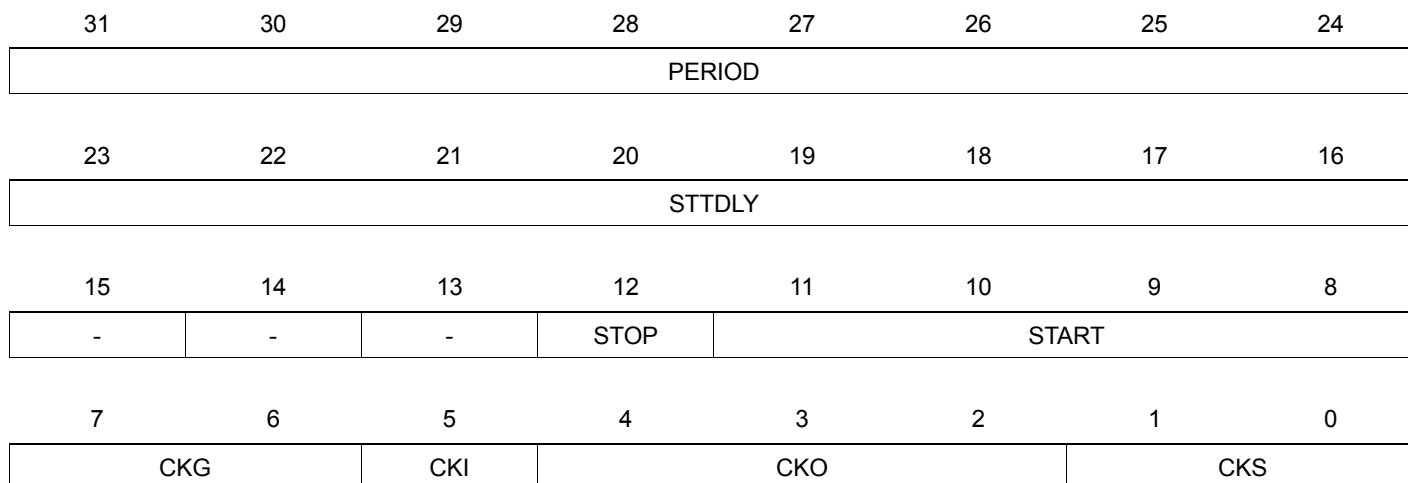

- **PERIOD: Receive Period Divider Selection**
 This field selects the divider to apply to the selected receive clock in order to generate a periodic Frame Sync Signal.
 If equal to zero, no signal is generated.
 If not equal to zero, a signal is generated each 2 x (PERIOD+1) receive clock periods.
- **STTDLY: Receive Start Delay**
 If STTDLY is not zero, a delay of STTDLY clock cycles is inserted between the start event and the actual start of reception.
 When the receiver is programmed to start synchronously with the transmitter, the delay is also applied.
 Note: It is very important that STTDLY be written carefully. If STTDLY must be written, it should be done in relation to Receive Sync Data reception.
- **STOP: Receive Stop Selection**
 1: After starting a receive with a Compare 0, the receiver operates in a continuous mode until a Compare 1 is detected.
 0: After completion of a data transfer when starting with a Compare 0, the receiver stops the data transfer and waits for a new Compare 0.

• **START: Receive Start Selection**

| START | Receive Start |
|--------|---|
| 0 | Continuous, as soon as the receiver is enabled, and immediately after the end of transfer of the previous data. |
| 1 | Transmit start |
| 2 | Detection of a low level on RX_FRAME_SYNC signal |
| 3 | Detection of a high level on RX_FRAME_SYNC signal |
| 4 | Detection of a falling edge on RX_FRAME_SYNC signal |
| 5 | Detection of a rising edge on RX_FRAME_SYNC signal |
| 6 | Detection of any level change on RX_FRAME_SYNC signal |
| 7 | Detection of any edge on RX_FRAME_SYNC signal |
| 8 | Compare 0 |
| Others | Reserved |

• **CKG: Receive Clock Gating Selection**

| CKG | Receive Clock Gating |
|-----|---|
| 0 | None, continuous clock |
| 1 | Receive Clock enabled only if RX_FRAME_SYNC is low |
| 2 | Receive Clock enabled only if RX_FRAME_SYNC is high |
| 3 | Reserved |

• **CKI: Receive Clock Inversion**

CKI affects only the receive clock and not the output clock signal.

1: The data inputs (Data and Frame Sync signals) are sampled on receive clock rising edge. The Frame Sync signal output is shifted out on receive clock falling edge.

0: The data inputs (Data and Frame Sync signals) are sampled on receive clock falling edge. The Frame Sync signal output is shifted out on receive clock rising edge.

• **CKO: Receive Clock Output Mode Selection**

| CKO | Receive Clock Output Mode | RX_CLOCK pin |
|--------|--|--------------|
| 0 | None | Input-only |
| 1 | Continuous receive clock | Output |
| 2 | Receive clock only during data transfers | Output |
| Others | Reserved | |

• **CKS: Receive Clock Selection**

| CKS | Selected Receive Clock |
|-----|------------------------|
| 0 | Divided clock |
| 1 | TX_CLOCK clock signal |
| 2 | RX_CLOCK pin |
| 3 | Reserved |

20.9.4 Receive Frame Mode Register

Name: RFMR
Access Type: Read/Write
Offset: 0x14
Reset value: 0x00000000

| | | | | | | | | |
|---------|------|------|--------|-------|----|----|---------|--|
| 31 | 30 | 29 | 28 | 27 | 26 | 25 | 24 | |
| FSLENHI | | | | - | - | - | FSEEDGE | |
| 23 | 22 | 21 | 20 | 19 | 18 | 17 | 16 | |
| - | FSOS | | | FSLEN | | | | |
| 15 | 14 | 13 | 12 | 11 | 10 | 9 | 8 | |
| - | - | - | - | DATNB | | | | |
| 7 | 6 | 5 | 4 | 3 | 2 | 1 | 0 | |
| MSBF | - | LOOP | DATLEN | | | | | |

- **FSLENHI: Receive Frame Sync Length High Part**
The four MSB of the FSLEN field.
- **FSEEDGE: Receive Frame Sync Edge Detection**
Determines which edge on Frame Sync will generate the SR.RXSYN interrupt.

| FSEEDGE | Frame Sync Edge Detection |
|---------|---------------------------|
| 0 | Positive edge detection |
| 1 | Negative edge detection |

- **FSOS: Receive Frame Sync Output Selection**

| FSOS | Selected Receive Frame Sync Signal | RX_FRAME_SYNC Pin |
|--------|---|-------------------|
| 0 | None | Input-only |
| 1 | Negative Pulse | Output |
| 2 | Positive Pulse | Output |
| 3 | Driven Low during data transfer | Output |
| 4 | Driven High during data transfer | Output |
| 5 | Toggling at each start of data transfer | Output |
| Others | Reserved | Undefined |

- **FSLEN: Receive Frame Sync Length**
This field defines the length of the Receive Frame Sync signal and the number of bits sampled and stored in the RSHR register. When this mode is selected by the RCMR.START field, it also determines the length of the sampled data to be compared to the Compare 0 or Compare 1 register.
Note: The four most significant bits for this field are located in the FSLENHI field.
The pulse length is equal to $\{FSLENHI, FSLEN\} + 1$ receive clock periods. Thus, if $\{FSLENHI, FSLEN\}$ is zero, the Receive Frame Sync signal is generated during one receive clock period.



- **DATNB: Data Number per Frame**
This field defines the number of data words to be received after each transfer start, which is equal to (DATNB + 1).
- **MSBF: Most Significant Bit First**
1: The most significant bit of the data register is sampled first in the bit stream.
0: The lowest significant bit of the data register is sampled first in the bit stream.
- **LOOP: Loop Mode**
1: RX_DATA is driven by TX_DATA, RX_FRAME_SYNC is driven by TX_FRAME_SYNC and TX_CLOCK drives RX_CLOCK.
0: Normal operating mode.
- **DATLEN: Data Length**
The bit stream contains (DATLEN + 1) data bits.
This field also defines the transfer size performed by the Peripheral DMA Controller assigned to the receiver.

| DATLEN | Transfer Size |
|--------|--------------------------------|
| 0 | Forbidden value |
| 1-7 | Data transfer are in bytes |
| 8-15 | Data transfer are in halfwords |
| Others | Data transfer are in words |

20.9.5 Transmit Clock Mode Register

Name: TCMR
Access Type: Read/Write
Offset: 0x18
Reset value: 0x00000000

| | | | | | | | | |
|--------|----|-----|-----|-------|----|-----|----|--|
| 31 | 30 | 29 | 28 | 27 | 26 | 25 | 24 | |
| PERIOD | | | | | | | | |
| 23 | 22 | 21 | 20 | 19 | 18 | 17 | 16 | |
| STTDLY | | | | | | | | |
| 15 | 14 | 13 | 12 | 11 | 10 | 9 | 8 | |
| - | - | - | - | START | | | | |
| 7 | 6 | 5 | 4 | 3 | 2 | 1 | 0 | |
| CKG | | CKI | CKO | | | CKS | | |

- PERIOD: Transmit Period Divider Selection**

This field selects the divider to apply to the selected transmit clock in order to generate a periodic Frame Sync Signal.
 If equal to zero, no signal is generated.
 If not equal to zero, a signal is generated each $2 \times (\text{PERIOD} + 1)$ transmit clock periods.

- STTDLY: Transmit Start Delay**

If STTDLY is not zero, a delay of STTDLY clock cycles is inserted between the start event and the actual start of transmission.
 When the transmitter is programmed to start synchronously with the receiver, the delay is also applied.
 Note: STTDLY must be written carefully, in relation to Transmit Sync Data transmission.

- START: Transmit Start Selection**

| START | Transmit Start |
|--------|--|
| 0 | Continuous, as soon as a word is written to the THR Register (if Transmit is enabled), and immediately after the end of transfer of the previous data. |
| 1 | Receive start |
| 2 | Detection of a low level on TX_FRAME_SYNC signal |
| 3 | Detection of a high level on TX_FRAME_SYNC signal |
| 4 | Detection of a falling edge on TX_FRAME_SYNC signal |
| 5 | Detection of a rising edge on TX_FRAME_SYNC signal |
| 6 | Detection of any level change on TX_FRAME_SYNC signal |
| 7 | Detection of any edge on TX_FRAME_SYNC signal |
| Others | Reserved |

• **CKG: Transmit Clock Gating Selection**

| CKG | Transmit Clock Gating |
|-----|--|
| 0 | None, continuous clock |
| 1 | Transmit Clock enabled only if TX_FRAME_SYNC is low |
| 2 | Transmit Clock enabled only if TX_FRAME_SYNC is high |
| 3 | Reserved |

• **CKI: Transmit Clock Inversion**

CKI affects only the Transmit Clock and not the output clock signal.

1: The data outputs (Data and Frame Sync signals) are shifted out on transmit clock rising edge. The Frame sync signal input is sampled on transmit clock falling edge.

0: The data outputs (Data and Frame Sync signals) are shifted out on transmit clock falling edge. The Frame sync signal input is sampled on transmit clock rising edge.

• **CKO: Transmit Clock Output Mode Selection**

| CKO | Transmit Clock Output Mode | TX_CLOCK pin |
|--------|---|--------------|
| 0 | None | Input-only |
| 1 | Continuous transmit clock | Output |
| 2 | Transmit clock only during data transfers | Output |
| Others | Reserved | |

• **CKS: Transmit Clock Selection**

| CKS | Selected Transmit Clock |
|-----|-------------------------|
| 0 | Divided Clock |
| 1 | RX_CLOCK clock signal |
| 2 | TX_CLOCK Pin |
| 3 | Reserved |

20.9.6 Transmit Frame Mode Register

Name: TFMR
Access Type: Read/Write
Offset: 0x1C
Reset value: 0x00000000

| | | | | | | | |
|---------|------|--------|--------|-------|----|----|---------|
| 31 | 30 | 29 | 28 | 27 | 26 | 25 | 24 |
| FSLENHI | | | | - | - | - | FSEEDGE |
| 23 | 22 | 21 | 20 | 19 | 18 | 17 | 16 |
| FSDEN | FSOS | | | FSLEN | | | |
| 15 | 14 | 13 | 12 | 11 | 10 | 9 | 8 |
| - | - | - | - | DATNB | | | |
| 7 | 6 | 5 | 4 | 3 | 2 | 1 | 0 |
| MSBF | - | DATDEF | DATLEN | | | | |

- **FSLENHI: Transmit Frame Sync Length High Part**
The four MSB of the FSLEN field.
- **FSEEDGE: Transmit Frame Sync Edge Detection**
Determines which edge on Frame Sync will generate the SR.TXSYN interrupt.

| FSEEDGE | Frame Sync Edge Detection |
|---------|---------------------------|
| 0 | Positive Edge Detection |
| 1 | Negative Edge Detection |

- **FSDEN: Transmit Frame Sync Data Enable**
1: TSHR value is shifted out during the transmission of the Transmit Frame Sync signal.
0: The TX_DATA line is driven with the default value during the Transmit Frame Sync signal.
- **FSOS: Transmit Frame Sync Output Selection**

| FSOS | Selected Transmit Frame Sync Signal | TX_FRAME_SYNC Pin |
|--------|---|-------------------|
| 0 | None | Input-only |
| 1 | Negative Pulse | Output |
| 2 | Positive Pulse | Output |
| 3 | Driven Low during data transfer | Output |
| 4 | Driven High during data transfer | Output |
| 5 | Toggling at each start of data transfer | Output |
| Others | Reserved | Undefined |

- **FSLEN: Transmit Frame Sync Length**
This field defines the length of the Transmit Frame Sync signal and the number of bits shifted out from the TSHR register if TFMR.FSDEN is equal to one.
Note: The four most significant bits for this field are located in the FSLENHI field.



The pulse length is equal to $\{\{FSLENHI,FSLEN\} + 1\}$ transmit clock periods, i.e., the pulse length can range from 1 to 256 transmit clock periods. If $\{FSLENHI,FSLEN\}$ is zero, the Transmit Frame Sync signal is generated during one transmit clock period.

- **DATNB: Data Number per Frame**

This field defines the number of data words to be transferred after each transfer start, which is equal to $(DATNB + 1)$.

- **MSBF: Most Significant Bit First**

1: The most significant bit of the data register is shifted out first in the bit stream.

0: The lowest significant bit of the data register is shifted out first in the bit stream.

- **DATDEF: Data Default Value**

This bit defines the level driven on the TX_DATA pin while out of transmission.

Note that if the pin is defined as multi-drive by the I/O Controller, the pin is enabled only if the TX_DATA output is one.

1: The level driven on the TX_DATA pin while out of transmission is one.

0: The level driven on the TX_DATA pin while out of transmission is zero.

- **DATLEN: Data Length**

The bit stream contains $(DATLEN + 1)$ data bits.

This field also defines the transfer size performed by the Peripheral DMA Controller assigned to the transmitter.

| DATLEN | Transfer Size |
|--------|--|
| 0 | Forbidden value (1-bit data length is not supported) |
| 1-7 | Data transfer are in bytes |
| 8-15 | Data transfer are in halfwords |
| Others | Data transfer are in words |

20.9.7 Receive Holding Register

Name: RHR
Access Type: Read-only
Offset: 0x20
Reset value: 0x00000000

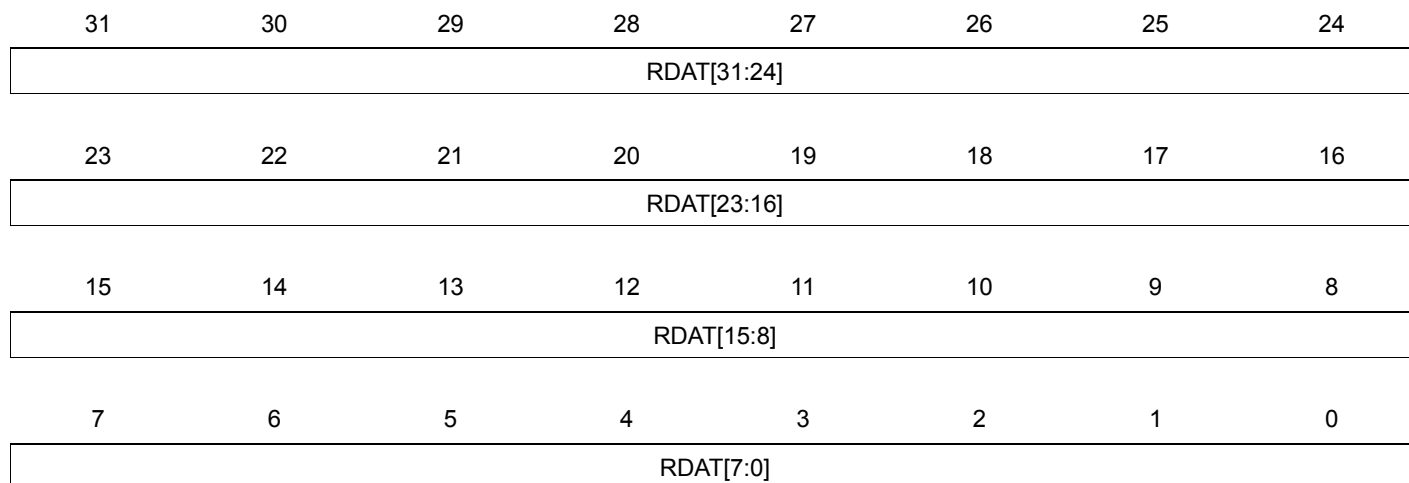

- **RDAT: Receive Data**

Right aligned regardless of the number of data bits defined by the RFMR.DATLEN field.

20.9.8 Transmit Holding Register

Name: THR
Access Type: Write-only
Offset: 0x24
Reset value: 0x00000000

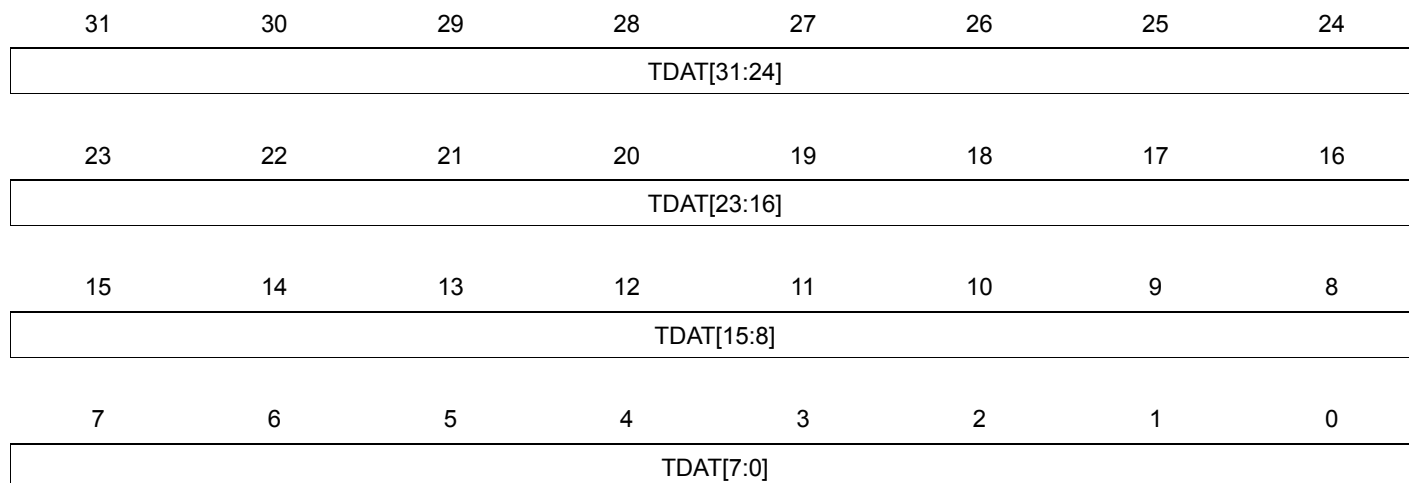

- **TDAT: Transmit Data**

Right aligned regardless of the number of data bits defined by the TFMR.DATLEN field.

20.9.9 Receive Synchronization Holding Register

Name: RSHR
Access Type: Read-only
Offset: 0x30
Reset value: 0x00000000

| | | | | | | | |
|-------------|----|----|----|----|----|----|----|
| 31 | 30 | 29 | 28 | 27 | 26 | 25 | 24 |
| - | - | - | - | - | - | - | - |
| 23 | 22 | 21 | 20 | 19 | 18 | 17 | 16 |
| - | - | - | - | - | - | - | - |
| 15 | 14 | 13 | 12 | 11 | 10 | 9 | 8 |
| RSDAT[15:8] | | | | | | | |
| 7 | 6 | 5 | 4 | 3 | 2 | 1 | 0 |
| RSDAT[7:0] | | | | | | | |

- RSDAT: Receive Synchronization Data

20.9.10 Transmit Synchronization Holding Register

Name: TSHR
Access Type: Read/Write
Offset: 0x34
Reset value: 0x00000000

| | | | | | | | |
|-------------|----|----|----|----|----|----|----|
| 31 | 30 | 29 | 28 | 27 | 26 | 25 | 24 |
| - | - | - | - | - | - | - | - |
| 23 | 22 | 21 | 20 | 19 | 18 | 17 | 16 |
| - | - | - | - | - | - | - | - |
| 15 | 14 | 13 | 12 | 11 | 10 | 9 | 8 |
| TSDAT[15:8] | | | | | | | |
| 7 | 6 | 5 | 4 | 3 | 2 | 1 | 0 |
| TSDAT[7:0] | | | | | | | |

- **TSDAT: Transmit Synchronization Data**

20.9.11 Receive Compare 0 Register

Name: RC0R
Access Type: Read/Write
Offset: 0x38
Reset value: 0x00000000

| | | | | | | | |
|-----------|----|----|----|----|----|----|----|
| 31 | 30 | 29 | 28 | 27 | 26 | 25 | 24 |
| - | - | - | - | - | - | - | - |
| 23 | 22 | 21 | 20 | 19 | 18 | 17 | 16 |
| - | - | - | - | - | - | - | - |
| 15 | 14 | 13 | 12 | 11 | 10 | 9 | 8 |
| CP0[15:8] | | | | | | | |
| 7 | 6 | 5 | 4 | 3 | 2 | 1 | 0 |
| CP0[7:0] | | | | | | | |

- CP0: Receive Compare Data 0

20.9.12 Receive Compare 1 Register

Name: RC1R
Access Type: Read/Write
Offset: 0x3C
Reset value: 0x00000000

| | | | | | | | |
|-------------|----|----|----|----|----|----|----|
| 31 | 30 | 29 | 28 | 27 | 26 | 25 | 24 |
| - | - | - | - | - | - | - | - |
| 23 | 22 | 21 | 20 | 19 | 18 | 17 | 16 |
| - | - | - | - | - | - | - | - |
| 15 | 14 | 13 | 12 | 11 | 10 | 9 | 8 |
| CP1[[15:8]] | | | | | | | |
| 7 | 6 | 5 | 4 | 3 | 2 | 1 | 0 |
| CP1[7:0] | | | | | | | |

- CP1: Receive Compare Data 1

20.9.13 Status Register

Name: SR
Access Type: Read-only
Offset: 0x40
Reset value: 0x000000CC

| | | | | | | | |
|----|----|-------|-------|-------|-------|---------|-------|
| 31 | 30 | 29 | 28 | 27 | 26 | 25 | 24 |
| - | - | - | - | - | - | - | - |
| 23 | 22 | 21 | 20 | 19 | 18 | 17 | 16 |
| - | - | - | - | - | - | RXEN | TXEN |
| 15 | 14 | 13 | 12 | 11 | 10 | 9 | 8 |
| - | - | - | - | RXSYN | TXSYN | CP1 | CP0 |
| 7 | 6 | 5 | 4 | 3 | 2 | 1 | 0 |
| - | - | OVRUN | RXRDY | - | - | TXEMPTY | TXRDY |

- **RXEN: Receive Enable**
 This bit is set when the CR.RXEN bit is written to one.
 This bit is cleared when no data are being processed and the CR.RXDIS bit has been written to one.
- **TXEN: Transmit Enable**
 This bit is set when the CR.TXEN bit is written to one.
 This bit is cleared when no data are being processed and the CR.TXDIS bit has been written to one.
- **RXSYN: Receive Sync**
 This bit is set when a Receive Sync has occurred.
 This bit is cleared when the SR register is read.
- **TXSYN: Transmit Sync**
 This bit is set when a Transmit Sync has occurred.
 This bit is cleared when the SR register is read.
- **CP1: Compare 1**
 This bit is set when compare 1 has occurred.
 This bit is cleared when the SR register is read.
- **CP0: Compare 0**
 This bit is set when compare 0 has occurred.
 This bit is cleared when the SR register is read.
- **OVRUN: Receive Overrun**
 This bit is set when data has been loaded in the RHR register while previous data has not yet been read.
 This bit is cleared when the SR register is read.
- **RXRDY: Receive Ready**
 This bit is set when data has been received and loaded in the RHR register.
 This bit is cleared when the RHR register is empty.
- **TXEMPTY: Transmit Empty**
 This bit is set when the last data written in the THR register has been loaded in the TSR register and last data loaded in the TSR register has been transmitted.
 This bit is cleared when data remains in the THR register or is currently transmitted from the TSR register.

- **TXRDY: Transmit Ready**

This bit is set when the THR register is empty.

This bit is cleared when data has been loaded in the THR register and is waiting to be loaded in the TSR register.

20.9.14 Interrupt Enable Register

Name: IER
Access Type: Write-only
Offset: 0x44
Reset value: 0x00000000

| | | | | | | | |
|----|----|-------|-------|-------|-------|---------|-------|
| 31 | 30 | 29 | 28 | 27 | 26 | 25 | 24 |
| - | - | - | - | - | - | - | - |
| 23 | 22 | 21 | 20 | 19 | 18 | 17 | 16 |
| - | - | - | - | - | - | - | - |
| 15 | 14 | 13 | 12 | 11 | 10 | 9 | 8 |
| - | - | - | - | RXSYN | TXSYN | CP1 | CP0 |
| 7 | 6 | 5 | 4 | 3 | 2 | 1 | 0 |
| - | - | OVRUN | RXRDY | - | - | TXEMPTY | TXRDY |

Writing a zero to a bit in this register has no effect.

Writing a one to a bit in this register will set the corresponding bit in IMR.

20.9.15 Interrupt Disable Register

Name: IDR
Access Type: Write-only
Offset: 0x48
Reset value: 0x00000000

| | | | | | | | |
|----|----|-------|-------|-------|-------|---------|-------|
| 31 | 30 | 29 | 28 | 27 | 26 | 25 | 24 |
| - | - | - | - | - | - | - | - |
| 23 | 22 | 21 | 20 | 19 | 18 | 17 | 16 |
| - | - | - | - | - | - | - | - |
| 15 | 14 | 13 | 12 | 11 | 10 | 9 | 8 |
| - | - | - | - | RXSYN | TXSYN | CP1 | CP0 |
| 7 | 6 | 5 | 4 | 3 | 2 | 1 | 0 |
| - | - | OVRUN | RXRDY | - | - | TXEMPTY | TXRDY |

Writing a zero to a bit in this register has no effect.

Writing a one to a bit in this register will clear the corresponding bit in IMR.

20.9.16 Interrupt Mask Register

Name: IMR
Access Type: Read-only
Offset: 0x4C
Reset value: 0x00000000

| | | | | | | | |
|----|----|-------|-------|-------|-------|---------|-------|
| 31 | 30 | 29 | 28 | 27 | 26 | 25 | 24 |
| - | - | - | - | - | - | - | - |
| 23 | 22 | 21 | 20 | 19 | 18 | 17 | 16 |
| - | - | - | - | - | - | - | - |
| 15 | 14 | 13 | 12 | 11 | 10 | 9 | 8 |
| - | - | - | - | RXSYN | TXSYN | CP1 | CP0 |
| 7 | 6 | 5 | 4 | 3 | 2 | 1 | 0 |
| - | - | OVRUN | RXRDY | - | - | TXEMPTY | TXRDY |

0: The corresponding interrupt is disabled.

1: The corresponding interrupt is enabled.

A bit in this register is cleared when the corresponding bit in IDR is written to one.

A bit in this register is set when the corresponding bit in IER is written to one.

21. Universal Synchronous Asynchronous Receiver Transmitter (USART)

Rev: 4.0.0.6

21.1 Features

- Configurable baud rate generator
- 5- to 9-bit full-duplex, synchronous and asynchronous, serial communication
 - 1, 1.5, or 2 stop bits in asynchronous mode, and 1 or 2 in synchronous mode
 - Parity generation and error detection
 - Framing- and overrun error detection
 - MSB- or LSB-first
 - Optional break generation and detection
 - Receiver frequency over-sampling by 8 or 16 times
 - Optional RTS-CTS hardware handshaking
 - Optional DTR-DSR-DCD-RI modem signal management
 - Receiver Time-out and transmitter Timeguard
 - Optional Multidrop mode with address generation and detection
- RS485 with line driver control
- ISO7816, T=0 and T=1 protocols for Interfacing with smart cards
 - , NACK handling, and customizable error counter
- IrDA modulation and demodulation
 - Communication at up to 115.2Kbit/s
- SPI Mode
 - Master or slave
 - Configurable serial clock phase and polarity
 - CLK SPI serial clock frequency up to a quarter of the CLK_USART internal clock frequency
- Test Modes
 - Automatic echo, remote- and local loopback
- Supports two Peripheral DMA Controller channels
 - Buffer transfers without processor intervention

21.2 Overview

The Universal Synchronous Asynchronous Receiver Transceiver (USART) provides a full duplex, universal, synchronous/asynchronous serial link. Data frame format is widely configurable, including basic length, parity, and stop bit settings, maximizing standards support. The receiver implements parity-, framing-, and overrun error detection, and can handle un-fixed frame lengths with the time-out feature. The USART supports several operating modes, providing an interface to RS485 and SPI buses, with ISO7816 T=0 and T=1 smart card slots, infrared transceivers, and modem port connections. Communication with slow and remote devices is eased by the timeguard. Duplex multidrop communication is supported by address and data differentiation through the parity bit. The hardware handshaking feature enables an out-of-band flow control, automatically managing RTS and CTS pins. The Peripheral DMA Controller connection enables memory transactions, and the USART supports chained buffer management without processor intervention. Automatic echo, remote-, and local loopback -test modes are also supported.

21.3 Block Diagram

Figure 21-1. USART Block Diagram

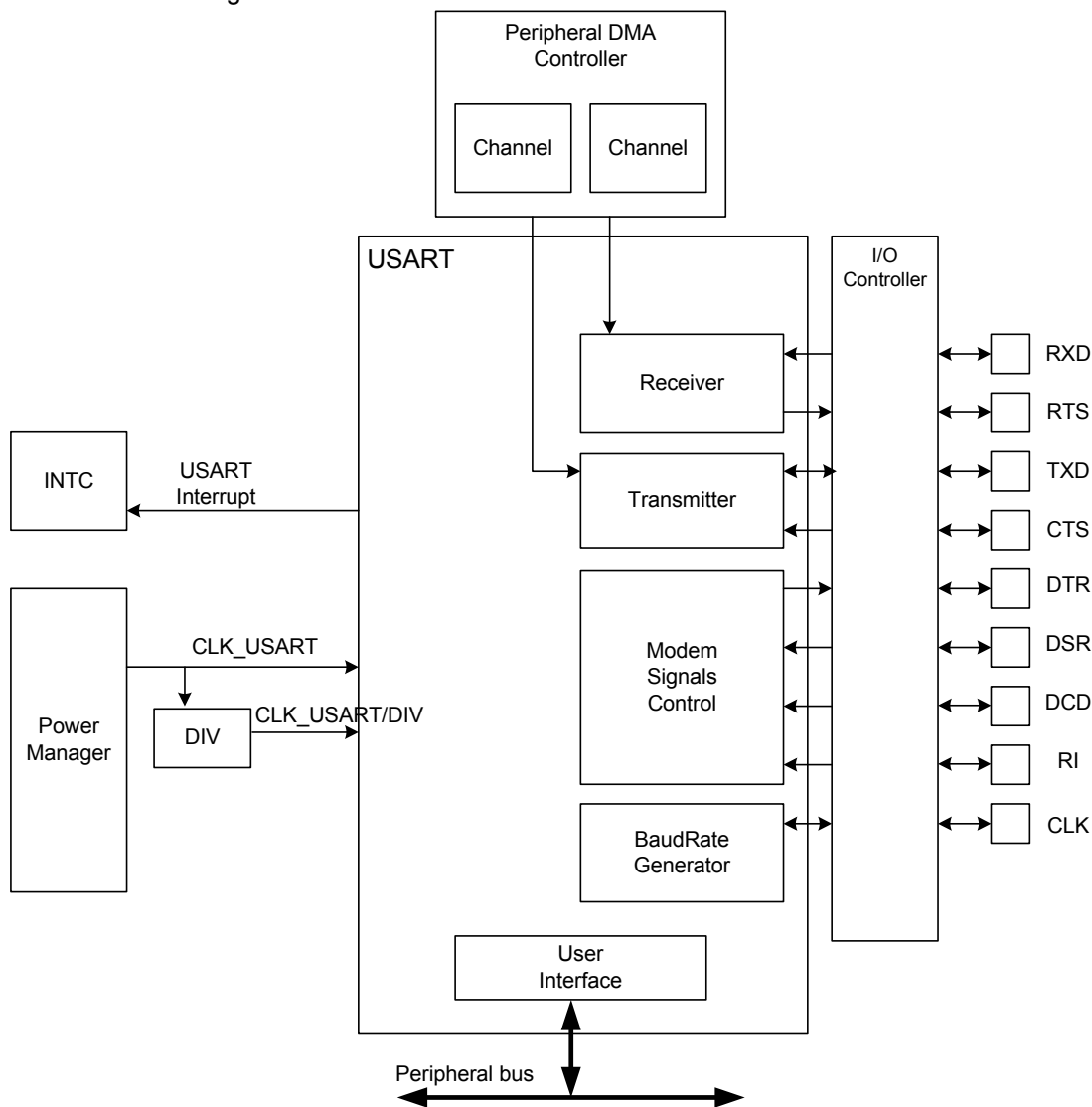

Table 21-1. SPI Operating Mode

| PIN | USART | SPI Slave | SPI Master |
|-----|-------|-----------|------------|
| RXD | RXD | MOSI | MISO |
| TXD | TXD | MISO | MOSI |
| RTS | RTS | – | CS |
| CTS | CTS | CS | – |

21.4 I/O Lines Description

Table 21-2. I/O Lines Description

| Name | Description | Type | Active Level |
|------|---|--------|--------------|
| CLK | Serial Clock | I/O | |
| TXD | Transmit Serial Data or Master Out Slave In (MOSI) in SPI master mode or Master In Slave Out (MISO) in SPI slave mode | Output | |
| RXD | Receive Serial Data or Master In Slave Out (MISO) in SPI master mode or Master Out Slave In (MOSI) in SPI slave mode | Input | |
| RI | Ring Indicator | Input | Low |
| DSR | Data Set Ready | Input | Low |
| DCD | Data Carrier Detect | Input | Low |
| DTR | Data Terminal Ready | Output | Low |
| CTS | Clear to Send or Slave Select (NSS) in SPI slave mode | Input | Low |
| RTS | Request to Send or Slave Select (NSS) in SPI master mode | Output | Low |

21.5 Product Dependencies

21.5.1 I/O Lines

The USART pins may be multiplexed with the I/O Controller lines. The user must first configure the I/O Controller to assign these pins to their peripheral functions. Unused I/O lines may be used for other purposes.

To prevent the TXD line from falling when the USART is disabled, the use of an internal pull up is required. If the hardware handshaking feature or modem mode is used, the internal pull up on TXD must also be enabled.

All the pins of the modems may or may not be implemented on the USART. On USARTs not equipped with the corresponding pins, the associated control bits and statuses have no effect on the behavior of the USART.

21.5.2 Clocks

The clock for the USART bus interface (CLK_USART) is generated by the Power Manager. This clock is enabled at reset, and can be disabled in the Power Manager. It is recommended to disable the USART before disabling the clock, to avoid freezing the USART in an undefined state.

21.5.3 Interrupts

The USART interrupt request line is connected to the interrupt controller. Using the USART interrupt requires the interrupt controller to be programmed first.

21.6 Functional Description

21.6.1 Selecting Mode

The USART can operate in several modes. The operating mode is selected by writing to the Mode field in the “Mode Register” (MR.MODE). In addition, Synchronous or Asynchronous mode is selected by writing to the Synchronous Mode Select bit in MR (MR.SYNC).

21.6.2 Baud Rate Generator

The baud rate generator provides the bit period clock named the Baud Rate Clock to both receiver and transmitter. It is based on a 16-bit divider, which is specified in the Clock Divider field in the Baud Rate Generator Register (BRGR.CD). A non-zero value enables the generator, and if CD is one, the divider is bypassed and inactive. The Clock Selection field in the Mode Register (MR.USCLKS) selects clock source between:

- CLK_USART (internal clock, refer to Power Manager chapter for details)
- CLK_USART/DIV (a divided CLK_USART, refer to Module Configuration section)
- CLK (external clock, available on the CLK pin)

If the external CLK clock is selected, the duration of the low and high levels of the signal provided on the CLK pin must be at least 4.5 times longer than those provided by CLK_USART.

Figure 21-2. Baud Rate Generator

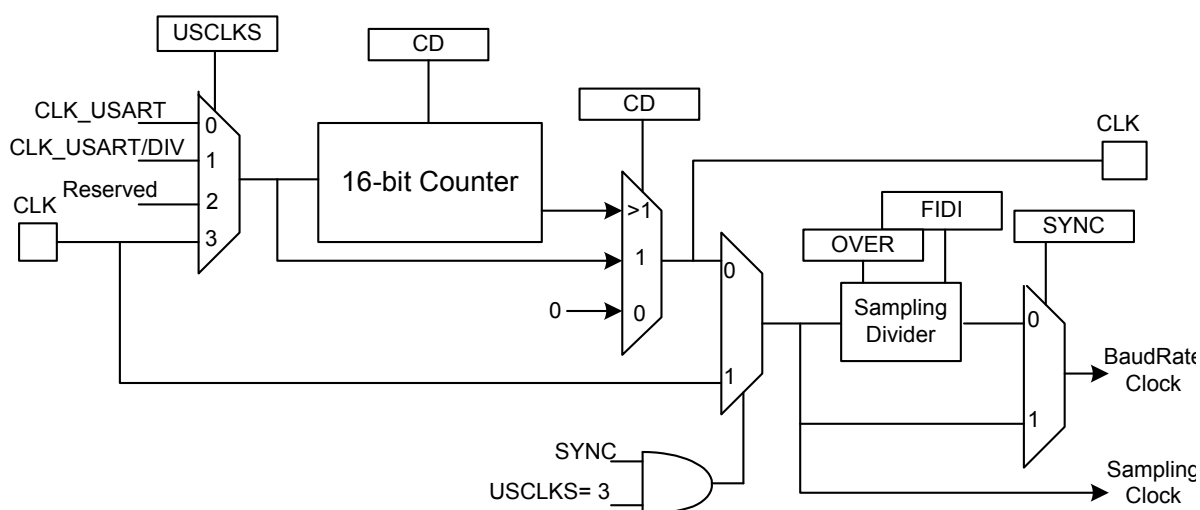

21.6.2.1 Baud Rate in Asynchronous Mode

If the USART is configured to operate in an asynchronous mode, the selected clock is divided by the CD value before it is provided to the receiver as a sampling clock. Depending on the Over-sampling Mode bit (MR.OVER) value, the clock is then divided by either 8 (OVER=1), or 16 (OVER=0). The baud rate is calculated with the following formula:

$$BaudRate = \frac{SelectedClock}{(8(2 - OVER)CD)}$$

This gives a maximum baud rate of CLK_USART divided by 8, assuming that CLK_USART is the fastest clock possible, and that OVER is one.

21.6.2.2 Baud Rate Calculation Example

Table 21-3 shows calculations based on the CD field to obtain 38400 baud from different source clock frequencies. This table also shows the actual resulting baud rate and error.

Table 21-3. Baud Rate Example (OVER=0)

| Source Clock (Hz) | Expected Baud Rate (bit/s) | Calculation Result | CD | Actual Baud Rate (bit/s) | Error |
|-------------------|----------------------------|--------------------|----|--------------------------|-------|
| 3 686 400 | 38 400 | 6.00 | 6 | 38 400.00 | 0.00% |
| 4 915 200 | 38 400 | 8.00 | 8 | 38 400.00 | 0.00% |
| 5 000 000 | 38 400 | 8.14 | 8 | 39 062.50 | 1.70% |
| 7 372 800 | 38 400 | 12.00 | 12 | 38 400.00 | 0.00% |
| 8 000 000 | 38 400 | 13.02 | 13 | 38 461.54 | 0.16% |
| 12 000 000 | 38 400 | 19.53 | 20 | 37 500.00 | 2.40% |
| 12 288 000 | 38 400 | 20.00 | 20 | 38 400.00 | 0.00% |
| 14 318 180 | 38 400 | 23.30 | 23 | 38 908.10 | 1.31% |
| 14 745 600 | 38 400 | 24.00 | 24 | 38 400.00 | 0.00% |
| 18 432 000 | 38 400 | 30.00 | 30 | 38 400.00 | 0.00% |
| 24 000 000 | 38 400 | 39.06 | 39 | 38 461.54 | 0.16% |
| 24 576 000 | 38 400 | 40.00 | 40 | 38 400.00 | 0.00% |
| 25 000 000 | 38 400 | 40.69 | 40 | 38 109.76 | 0.76% |
| 32 000 000 | 38 400 | 52.08 | 52 | 38 461.54 | 0.16% |
| 32 768 000 | 38 400 | 53.33 | 53 | 38 641.51 | 0.63% |
| 33 000 000 | 38 400 | 53.71 | 54 | 38 194.44 | 0.54% |
| 40 000 000 | 38 400 | 65.10 | 65 | 38 461.54 | 0.16% |
| 50 000 000 | 38 400 | 81.38 | 81 | 38 580.25 | 0.47% |
| 60 000 000 | 38 400 | 97.66 | 98 | 38 265.31 | 0.35% |

The baud rate is calculated with the following formula (OVER=0):

$$BaudRate = (CLKUSART)/(CD \times 16)$$

The baud rate error is calculated with the following formula. It is not recommended to work with an error higher than 5%.

$$Error = 1 - \left(\frac{ExpectedBaudRate}{ActualBaudRate} \right)$$

21.6.2.3 Fractional Baud Rate in Asynchronous Mode

The baud rate generator has a limitation: the source frequency is always a multiple of the baud rate. An approach to this problem is to integrate a high resolution fractional N clock generator, outputting fractional multiples of the reference source clock. This fractional part is selected with the Fractional Part field (BRGR.FP), and is activated by giving it a non-zero value. The resolution is one eighth of CD. The resulting baud rate is calculated using the following formula:

$$BaudRate = \frac{SelectedClock}{\left(8(2 - OVER) \left(CD + \frac{FP}{8} \right) \right)}$$

The modified architecture is presented below:

Figure 21-3. Fractional Baud Rate Generator

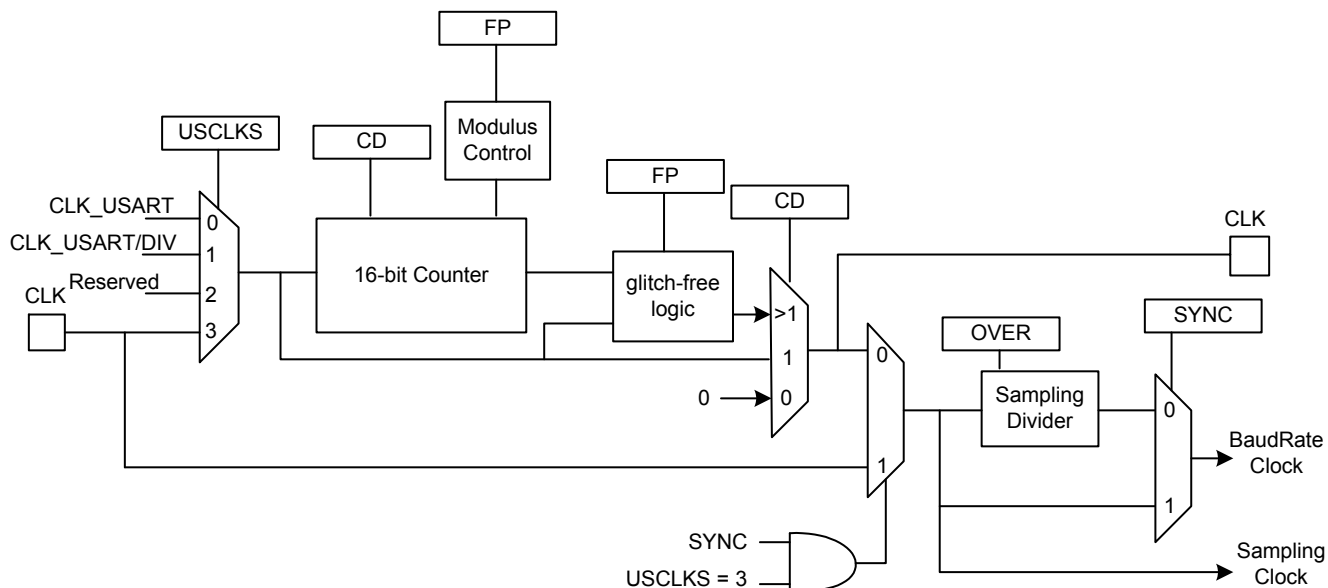

21.6.2.4 Baud Rate in Synchronous and SPI Mode

If the USART is configured to operate in synchronous mode, the selected clock is divided by the BRGR.CD field. This does not apply when CLK is selected.

$$BaudRate = \frac{SelectedClock}{CD}$$

When CLK is selected the external frequency must be at least 4.5 times lower than the system clock, and when either CLK or CLK_USART/DIV are selected, CD must be even to ensure a 50/50 duty cycle. If CLK_USART is selected, the generator ensures this regardless of value.

21.6.2.5 Baud Rate in ISO 7816 Mode

The ISO7816 specification defines the bit rate with the following formula:

$$B = \frac{D_i}{F_i} \times f$$

where:

- B is the bit rate
- Di is the bit-rate adjustment factor
- Fi is the clock frequency division factor
- f is the ISO7816 clock frequency (Hz)

Di is a binary value encoded on a 4-bit field, named DI, as represented in [Table 21-4](#).

Table 21-4. Binary and Decimal Values for Di

| | | | | | | | | |
|--------------|------|------|------|------|------|------|------|------|
| DI field | 0001 | 0010 | 0011 | 0100 | 0101 | 0110 | 1000 | 1001 |
| Di (decimal) | 1 | 2 | 4 | 8 | 16 | 32 | 12 | 20 |

Fi is a binary value encoded on a 4-bit field, named FI, as represented in [Table 21-5](#).

Table 21-5. Binary and Decimal Values for Fi

| | | | | | | | | | | | | |
|--------------|------|------|------|------|------|------|------|------|------|------|------|------|
| FI field | 0000 | 0001 | 0010 | 0011 | 0100 | 0101 | 0110 | 1001 | 1010 | 1011 | 1100 | 1101 |
| Fi (decimal) | 372 | 372 | 558 | 744 | 1116 | 1488 | 1860 | 512 | 768 | 1024 | 1536 | 2048 |

[Table 21-6](#) shows the resulting Fi/Di ratio, which is the ratio between the ISO7816 clock and the baud rate clock.

Table 21-6. Possible Values for the Fi/Di Ratio

| Fi | 372 | 558 | 744 | 1116 | 1488 | 1860 | 512 | 768 | 1024 | 1536 | 2048 |
|-------|-------|-------|-------|-------|------|-------|-------|------|-------|------|-------|
| Di=2 | 186 | 279 | 372 | 558 | 744 | 930 | 256 | 384 | 512 | 768 | 1024 |
| Di=4 | 93 | 139.5 | 186 | 279 | 372 | 465 | 128 | 192 | 256 | 384 | 512 |
| Di=8 | 46.5 | 69.75 | 93 | 139.5 | 186 | 232.5 | 64 | 96 | 128 | 192 | 256 |
| Di=16 | 23.25 | 34.87 | 46.5 | 69.75 | 93 | 116.2 | 32 | 48 | 64 | 96 | 128 |
| Di=32 | 11.62 | 17.43 | 23.25 | 34.87 | 46.5 | 58.13 | 16 | 24 | 32 | 48 | 64 |
| Di=12 | 31 | 46.5 | 62 | 93 | 124 | 155 | 42.66 | 64 | 85.33 | 128 | 170.6 |
| Di=20 | 18.6 | 27.9 | 37.2 | 55.8 | 74.4 | 93 | 25.6 | 38.4 | 51.2 | 76.8 | 102.4 |

If the USART is configured to run in ISO7816 mode, the clock selected by the MR.USCLKS field is first divided by the CD value before it can be output on the CLK pin, to feed the smart card clock inputs, by writing a one to the Clock Output Select bit (MR.CLK0). It is then divided by the FI Over DI Ratio Value field in the FI DI Ratio Register (FIDI.FI_DI_RATIO), which can be up to 2047 in ISO7816 mode. This will be rounded off to an integral so the user has to select a FI_DI_RATIO value that comes as close as possible to the expected Fi/Di ratio. The FI_DI_RATIO reset value is 0x174 (372 in decimal) and is the most common divider between the ISO7816 clock and bit rate (Fi=372, Di=1). [Figure 21-4](#) shows the relationship between the Elementary Time Unit (ETU), corresponding to a bit period, and the ISO 7816 clock.

Figure 21-4. Elementary Time Unit (ETU)

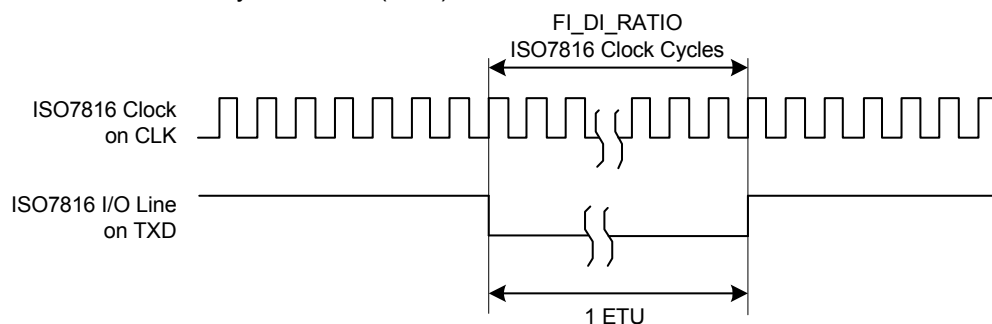

21.6.3 Receiver and Transmitter Control

After a reset, the transceiver is disabled. The receiver/transmitter is enabled by writing a one to either the Receiver Enable, or Transmitter Enable bit in the Control Register (CR.RXEN, or CR.TXEN). They may be enabled together and can be configured both before and after they have been enabled. The user can reset the USART receiver/transmitter at any time by writing a one to either the Reset Receiver (CR.RSTRX), or Reset Transmitter (CR.RSTTX) bit. This software reset clears status bits and resets internal state machines, immediately halting any communication. The user interface configuration registers will retain their values.

The user can disable the receiver/transmitter by writing a one to either the Receiver Disable, or Transmitter Disable bit (CR.RXDIS, or CR.TXDIS). If the receiver is disabled during a character reception, the USART will wait for the current character to be received before disabling. If the transmitter is disabled during transmission, the USART will wait until both the current character and the character stored in the Transmitter Holding Register (THR) are transmitted before disabling. If a timeguard has been implemented it will remain functional during the transaction.

21.6.4 Synchronous and Asynchronous Modes

21.6.4.1 Transmitter Operations

The transmitter performs equally in both synchronous and asynchronous operating modes (MR.SYNC). One start bit, up to 9 data bits, an optional parity bit, and up to two stop bits are successively shifted out on the TXD pin at each falling edge of the serial clock. The number of data bits is selected by the Character Length field (MR.CHRL) and the MR.MODE9 bit. Nine bits are selected by writing a one to MODE9, overriding any value in CHRL. The parity bit configuration is selected in the MR.PAR field. The Most Significant Bit First bit (MR.MSBF) selects which data bit to send first. The number of stop bits is selected by the MR.NBSTOP field. The 1.5 stop bit configuration is only supported in asynchronous mode.

Figure 21-5. Character Transmit

Example: 8-bit, Parity Enabled One Stop

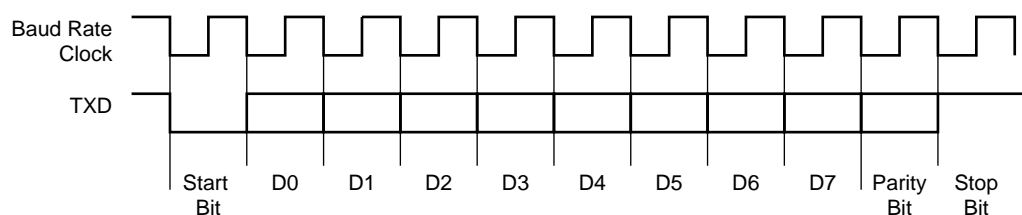

The characters are sent by writing to the Character to be Transmitted field (THR.TXCHR). The transmitter reports status with the Transmitter Ready (TXRDY) and Transmitter Empty (TXEMPTY) bits in the Channel Status Register (CSR). TXRDY is set when THR is empty. TXEMPTY is set when both THR and the transmit shift register are empty (transmission complete). Both TXRDY and TXEMPTY are cleared when the transmitter is disabled. Writing a character to THR while TXRDY is zero has no effect and the written character will be lost.

Figure 21-6. Transmitter Status

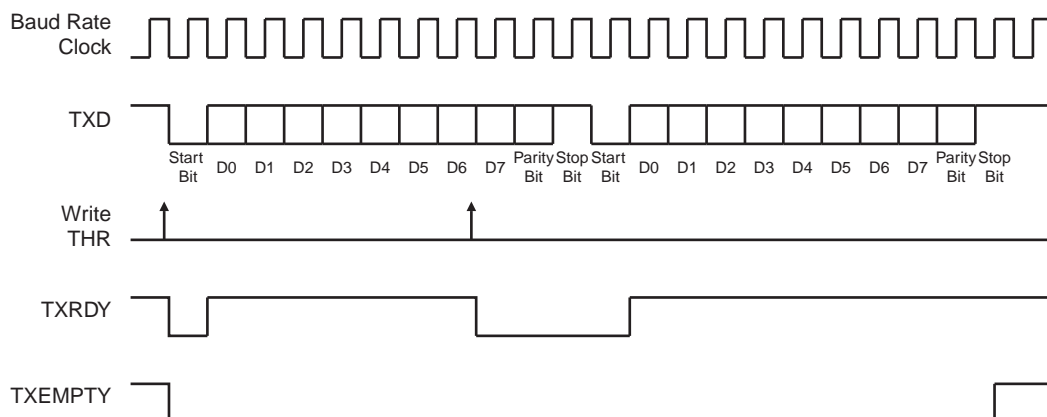

21.6.4.2 Manchester Encoder

When the Manchester encoder is used, characters transmitted through the USART are encoded in Manchester II Biphase format. To enable this mode, write a one to MR.MAN. Depending on polarity configuration, as selected by the Transmission Manchester Polarity bit in the Manchester Configuration Register (MAN.TX_MOPL), a logic level (zero or one), is transmitted as the transition from high-to-low or low-to-high during the middle of each bit period. This consumes twice the bandwidth than the simpler NRZ coding schemes, but the receiver has more error control since the expected input has a transition at every mid-bit period. An example of a Manchester encoded sequence is the byte 0xB1 or 10110001 being encoded to 10 01 10 10 01 01 10, assuming default encoder polarity. [Figure 21-7](#) illustrates this coding scheme.

Figure 21-7. NRZ to Manchester Encoding

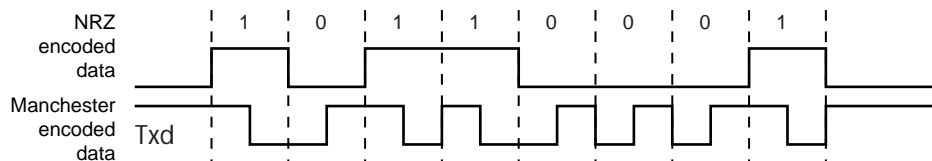

A Manchester encoded character can be preceded by both a preamble sequence, and a start frame delimiter. The preamble sequence is a pre-defined pattern with a configurable length from 1 to 15 bit periods. If the preamble length is zero, the preamble waveform is not generated. The length is selected by writing to the Transmitter Preamble Length field (MAN.TX_PL). The available preamble sequence patterns are: ALL_ONE, ALL_ZERO, ONE_ZERO or ZERO_ONE, and are selected by writing to the Transmitter Preamble Pattern field (MAN.TX_PP). [Figure 21-8](#) illustrates the supported patterns.

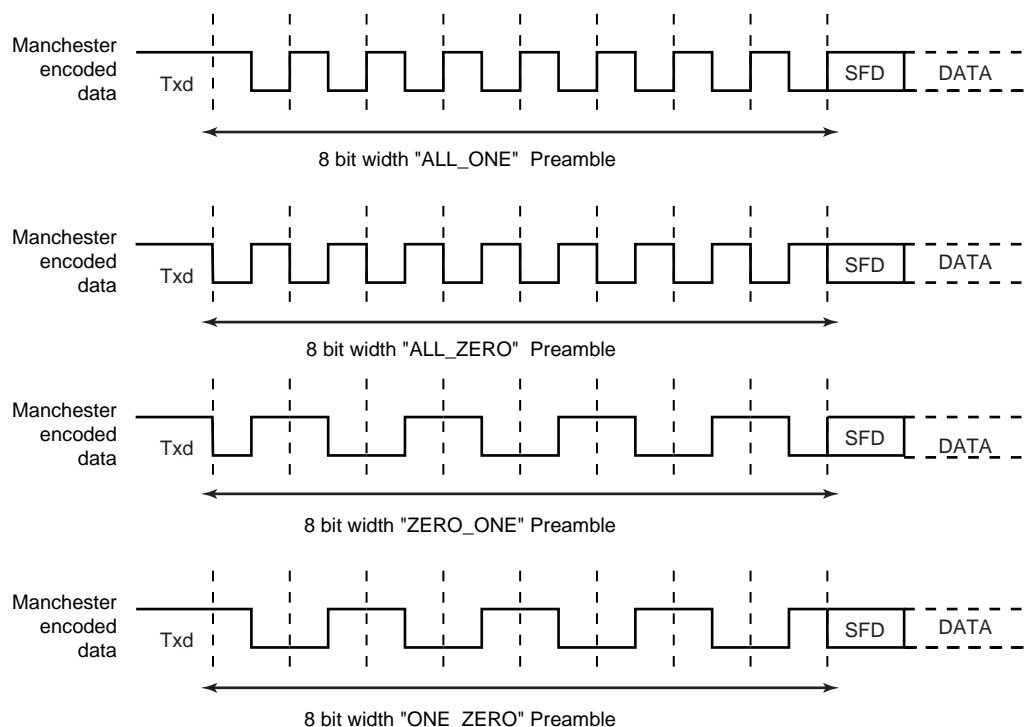
Figure 21-8. Preamble Patterns, Default Polarity Assumed

The Start Frame Delimiter Selector bit (MR.ONEBIT) configures the Manchester start bit pattern following the preamble. If MR.ONEBIT is one, a Manchester encoded zero is transmitted to indicate that a new character is about to be sent. If MR.ONEBIT is zero, a synchronization pattern is sent for the duration of three bit periods to inaugurate the new character. The sync pattern waveform by itself is an invalid Manchester encoding, since the transition only occurs at the middle of the second bit period.

The Manchester Synchronization Mode bit (MR.MODSYNC) selects sync pattern, and this also defines if the character is data (MODSYNC=0) with a zero to one transition, or a command (MODSYNC=1) with a one to zero transition. When direct memory access is used, the sync pattern can be updated on-the-fly with a modified character located in memory. To enable this mode the Variable Synchronization of Command/Data Sync Start Frame Delimiter bit (MR.VAR_SYNC) has to be written to one. In this case, MODSYNC is bypassed and THR.TXSYNH selects the sync type to be included. [Figure 21-9](#) illustrates supported patterns.

Figure 21-9. Start Frame Delimiter

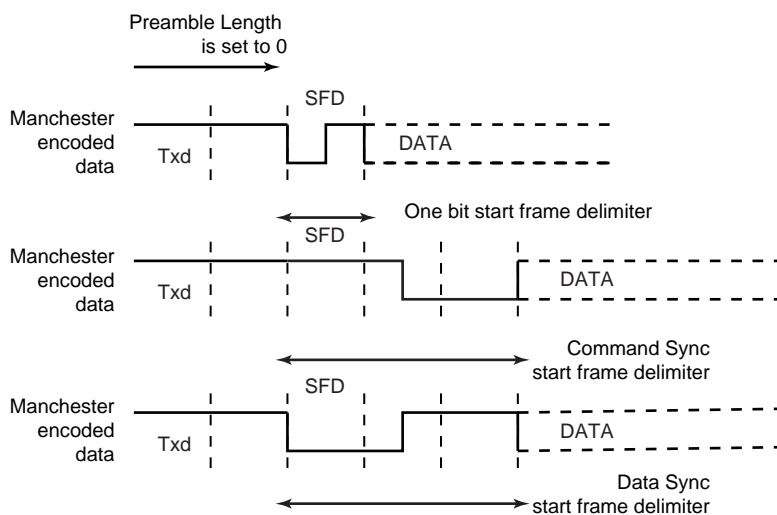

Manchester Drift Compensation

The Drift compensation bit (MAN.DRIFT) enables a hardware drift compensation and recovery system that allows for sub-optimal clock drifts without further user intervention. Drift compensation is only available in 16x oversampling mode. If the RXD event is one 16th clock cycle from the expected edge, it is considered as normal jitter and no corrective action will be taken. If the event is two to four 16th's early, the current period will be shortened by a 16th. If the event is two to three 16th's after the expected edge, the current period will be prolonged by a 16th.

Figure 21-10. Bit Resynchronization

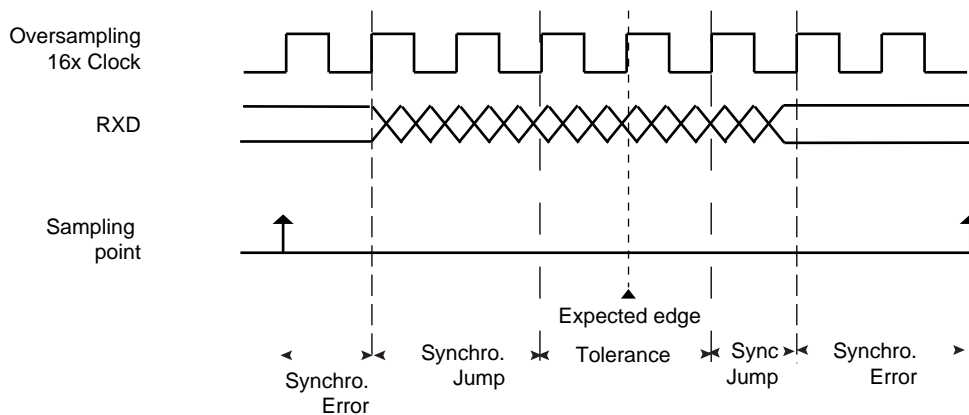

21.6.4.3 Asynchronous Receiver

If the USART is configured in an asynchronous operating mode (MR.SYNC = 0), the receiver will oversample the RXD input line by either 8 or 16 times the baud rate clock, as selected by the Oversampling Mode bit (MR.OVER). If the line is zero for half a bit period (four or eight consecutive samples, respectively), a start bit will be assumed, and the following 8th or 16th sample will determine the logical value on the line, in effect resulting in bit values being determined at the middle of the bit period.

The number of data bits, endianness, parity mode, and stop bits are selected by the same bits and fields as for the transmitter (MR.CHRL, MODE9, MSBF, PAR, and NBSTOP). The synchro-

nization mechanism will only consider one stop bit, regardless of the used protocol, and when the first stop bit has been sampled, the receiver will automatically begin looking for a new start bit, enabling resynchronization even if there is a protocol miss-match. [Figure 21-11](#) and [Figure 21-12](#) illustrate start bit detection and character reception in asynchronous mode.

Figure 21-11. Asynchronous Start Bit Detection

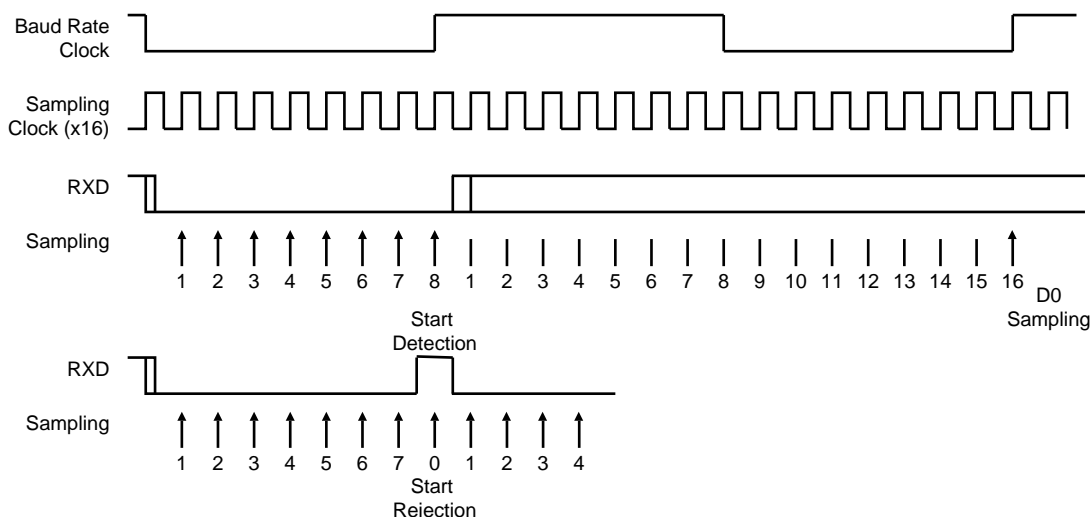
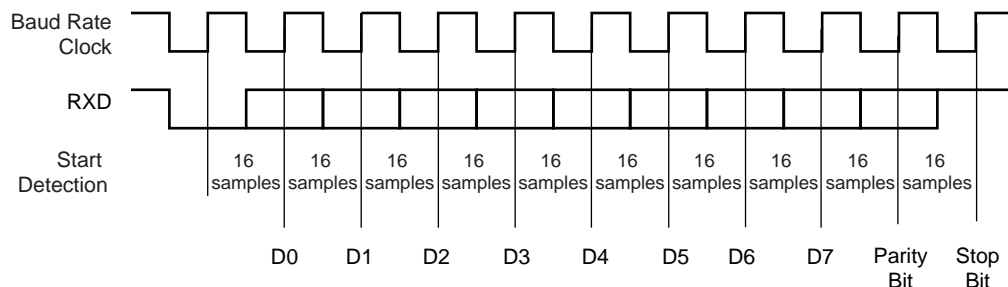

Figure 21-12. Asynchronous Character Reception

Example: 8-bit, Parity Enabled



21.6.4.4 Manchester Decoder

When MR.MAN is one, the Manchester endec is enabled. The decoder can detect selectable preamble sequences and start frame delimiters. The Receiver Manchester Polarity bit (MAN.RX_MPOL) selects input stream polarity. The Receiver Preamble Length field (MAN.RX_PL) specifies the length characteristics of detectable preambles, and if written to zero the preamble pattern detection will be disabled. The Receiver Preamble Pattern field (MAN.RX_PP) selects the pattern to be detected. See [Figure 21-8](#) for available preamble patterns. [Figure 21-13](#) illustrates two types of Manchester preamble pattern mismatches.

The Manchester endec uses the same Start Frame Delimiter Selector (MR.ONEBIT) for both encoder and decoder. If ONEBIT is one, only a Manchester encoded zero will be accepted as a valid start frame delimiter. If ONEBIT is zero, a data or command sync pattern will be expected. The Received Sync bit in the Receive Holding Register (RHR.RXSYNH) will be zero if it is a data sync, and a one if it is a command sync.

Figure 21-13. Preamble Pattern Mismatch

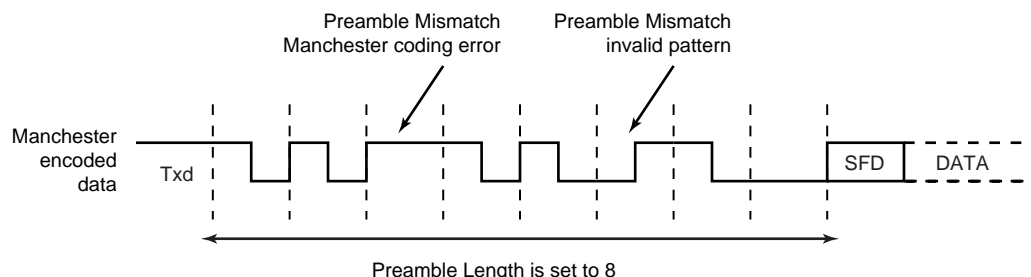

The receiver samples the RX line in continuous bit period quarters, making the smallest time frame in which to assume a bit value three quarters. A start bit is assumed if RXD is zero during one of these quarters. See Figure 21-14.

Figure 21-14. Asynchronous Start Bit Detection

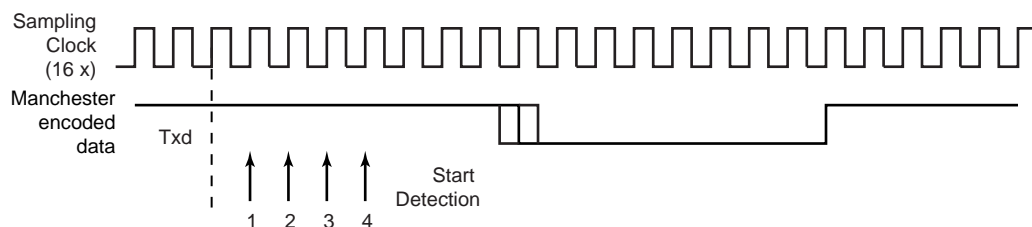

If a valid preamble pattern or start frame delimiter is detected, the receiver continues decoding with the same synchronization. If the stream does not match a valid preamble pattern or a start frame delimiter, the receiver re-synchronizes at the next valid edge. When a valid start sequence has been detected, the decoded data is passed to the USART and the user will be notified of any incoming Manchester encoding violations by the Manchester Error bit (CSR.MANE). This bit is cleared by writing a one to the Reset Status bits in the Control Register (CR.RSTSTA). A violation occurs when there is no transition in the middle of a bit period. See Figure 21-15 for an illustration of a violation causing the Manchester Error bit to be set.

Figure 21-15. Manchester Error

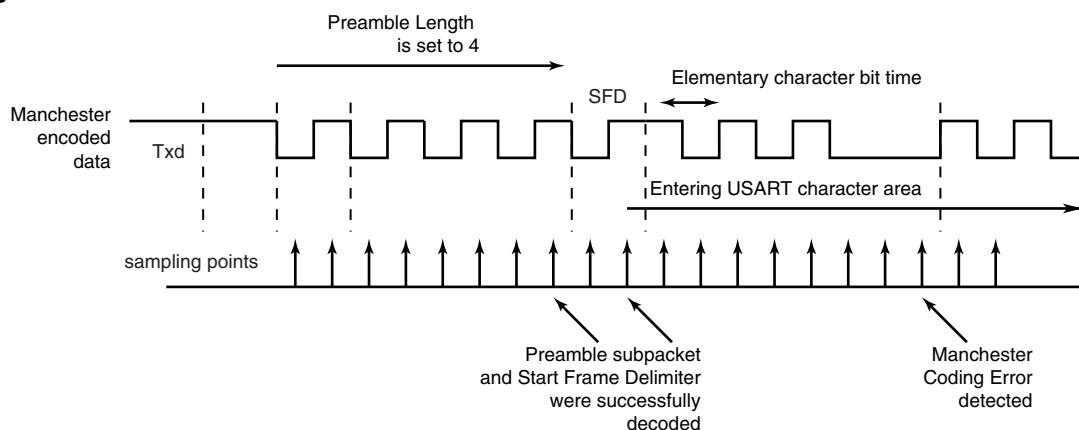

21.6.4.5 Radio Interface: Manchester Endec Application

This section describes low data rate, full duplex, dual frequency, RF systems integrated with a Manchester endec, that support ASK and/or FSK modulation schemes. See Figure 21-16.

Figure 21-16. Manchester Encoded Characters RF Transmission

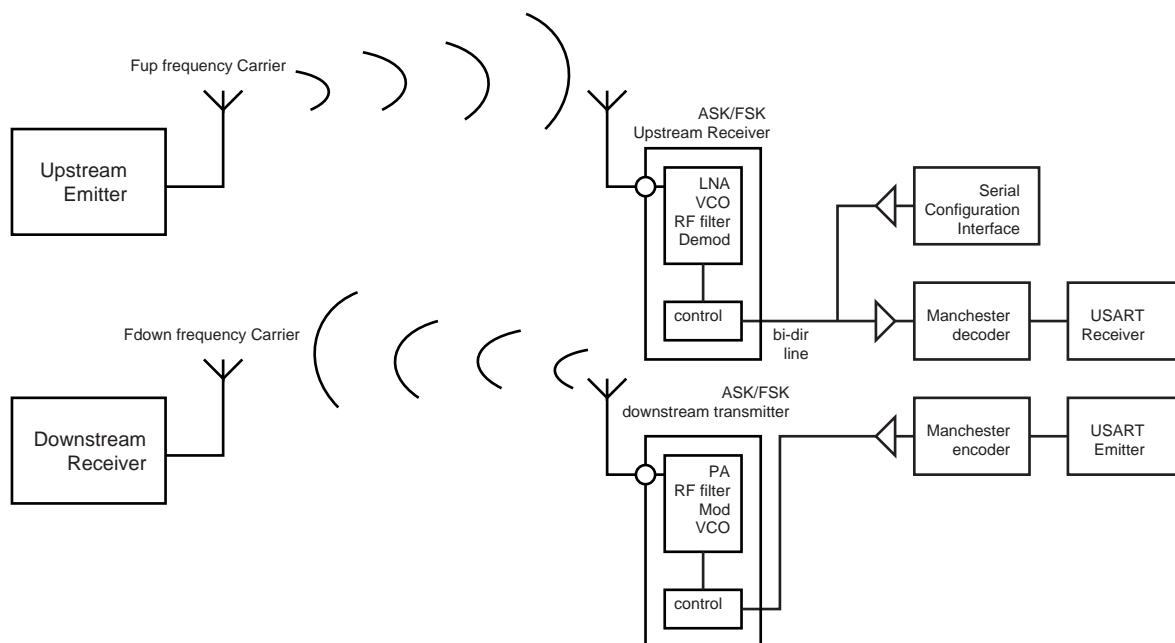

To transmit downstream, encoded data is sent serially to the RF modulator and then through space to the RF receiver. To receive, another frequency carrier is used and the RF demodulator does a bit-checking search for valid patterns before it switches to a receiving mode and forwards data to the decoder. Defining preambles to help distinguish between noise and valid data has to be done in conjunction with the RF module, and may sometimes be filtered away from the end stream. Using the ASK modulation scheme, a one is transmitted as a RF signal at the downstream frequency, while a zero is transmitted as no signal. See [Figure 21-17](#) The FSK modulation scheme uses two different frequencies to transmit data. A one is sent as a signal on one frequency, and a zero on the other. See [Figure 21-18](#).

Figure 21-17. ASK Modulator Output

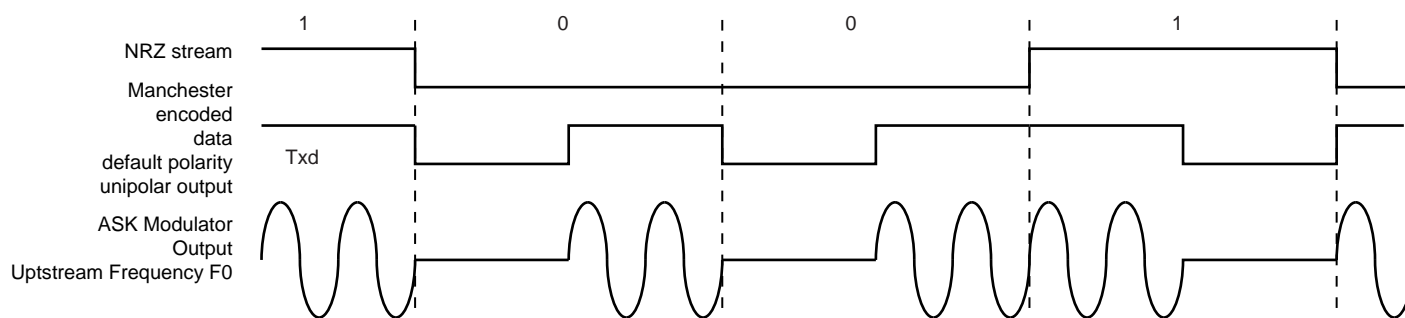
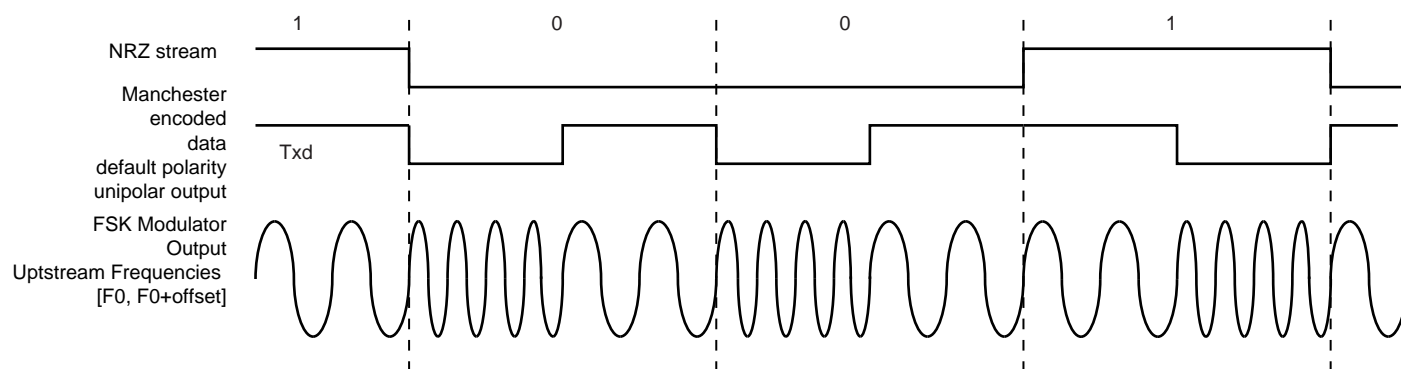

Figure 21-18. FSK Modulator Output



21.6.4.6 Synchronous Receiver

In synchronous mode (SYNC=1), the receiver samples the RXD signal on each rising edge of the Baud Rate Clock. If a low level is detected, it is considered as a start bit. Configuration bits and fields are the same as in asynchronous mode.

Figure 21-19. Synchronous Mode Character Reception

Example: 8-bit, Parity Enabled 1 Stop

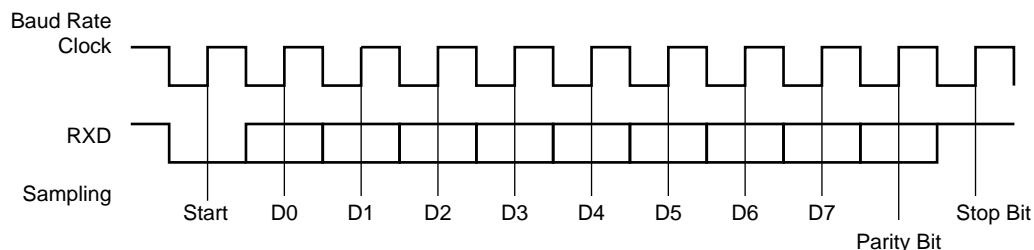

21.6.4.7 Receiver Operations

When a character reception is completed, it is transferred to the Received Character field in the Receive Holding Register (RHR.RXCHR), and the Receiver Ready bit in the Channel Status Register (CSR.RXRDY) is set. If RXRDY is already set, RHR will be overwritten and the Overrun Error bit (CSR.OVRE) is set. Reading RHR will clear CSR.RXRDY, and writing a one to the Reset Status bit in the Control Register (CR.RSTSTA) will clear CSR.OVRE.

Figure 21-20. Receiver Status

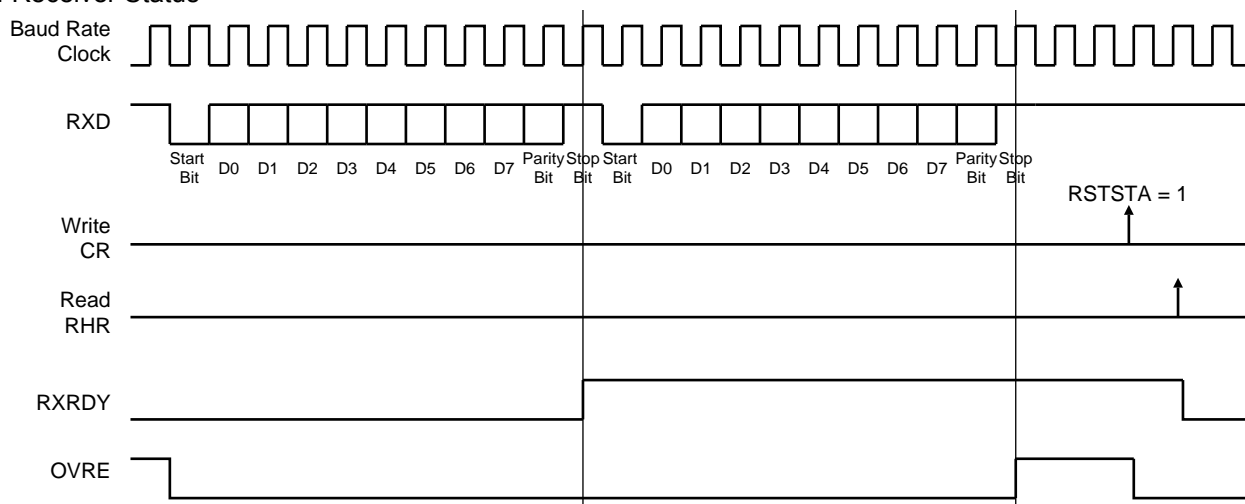

21.6.4.8 Parity

The USART supports five parity modes selected by MR.PAR. The PAR field also enables the Multidrop mode, see "Multidrop Mode" on page 313. If even parity is selected, the parity bit will be a zero if there is an even number of ones in the data character, and if there is an odd number it will be a one. For odd parity the reverse applies. If space or mark parity is chosen, the parity bit will always be a zero or one, respectively. See Table 21-7.

Table 21-7. Parity Bit Examples

| Alphanum Character | Hex | Bin | Parity Mode | | | | |
|--------------------|------|-----------|-------------|------|------|-------|------|
| | | | Odd | Even | Mark | Space | None |
| A | 0x41 | 0100 0001 | 1 | 0 | 1 | 0 | - |
| V | 0x56 | 0101 0110 | 1 | 0 | 1 | 0 | - |
| R | 0x52 | 0101 0010 | 0 | 1 | 1 | 0 | - |

The receiver will report parity errors in CSR.PARE, unless parity is disabled. Writing a one to CR.RSTSTA will clear CSR.PARE. See Figure 21-21.

Figure 21-21. Parity Error

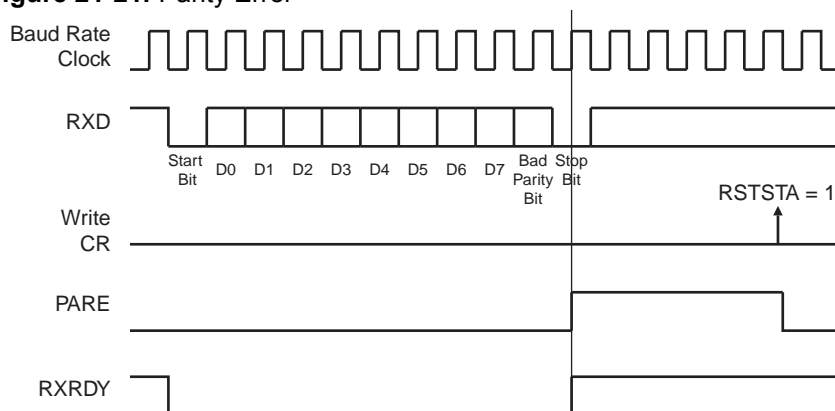

21.6.4.9 Multidrop Mode

If PAR is either 0x6 or 0x7, the USART runs in Multidrop mode. This mode differentiates data and address characters. Data has the parity bit zero and addresses have a one. By writing a one to the Send Address bit (CR.SENDA) the user will cause the next character written to THR to be transmitted as an address. Receiving a character with a one as parity bit will set CSR.PARE.

21.6.4.10 Transmitter Timeguard

The timeguard feature enables the USART to interface slow devices by inserting an idle state on the TXD line in between two characters. This idle state corresponds to a long stop bit, whose duration is selected by the Timeguard Value field in the Transmitter Timeguard Register (TTGR.TG). The transmitter will hold the TXD line high for TG bit periods, in addition to the number of stop bits. As illustrated in Figure 21-22, the behavior of TXRDY and TXEMPTY is modified when TG has a non-zero value. If a pending character has been written to THR, the TXRDY bit will not be set until this characters start bit has been sent. TXEMPTY will remain low until the timeguard transmission has completed.

Figure 21-22. Timeguard Operation

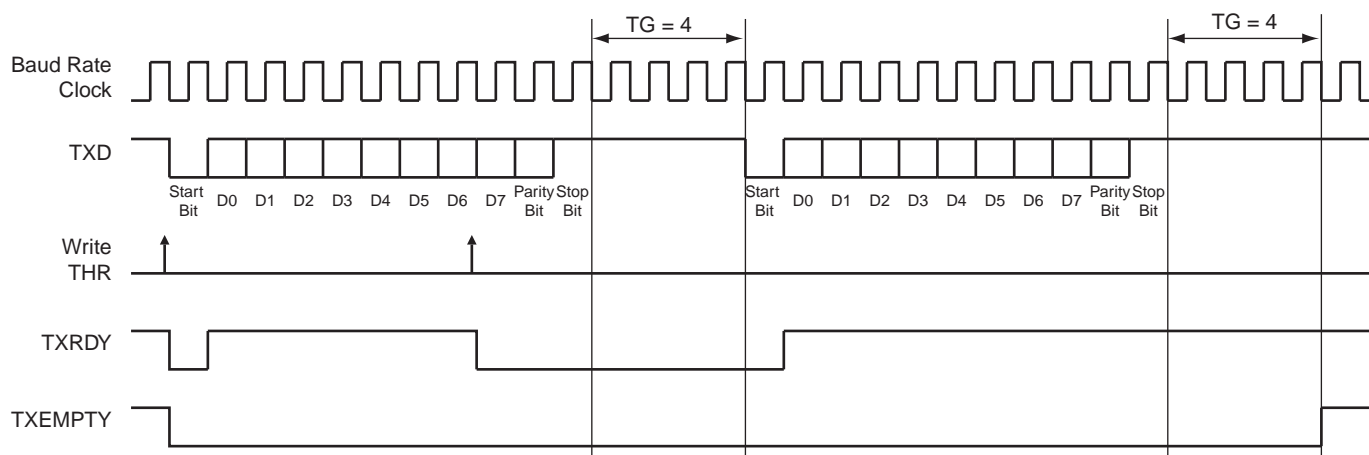

Table 21-8. Maximum Baud Rate Dependent Timeguard Durations

| Baud Rate (bit/sec) | Bit time (μs) | Timeguard (ms) |
|---------------------|---------------|----------------|
| 1 200 | 833 | 212.50 |
| 9 600 | 104 | 26.56 |
| 14400 | 69.4 | 17.71 |
| 19200 | 52.1 | 13.28 |
| 28800 | 34.7 | 8.85 |
| 33400 | 29.9 | 7.63 |
| 56000 | 17.9 | 4.55 |
| 57600 | 17.4 | 4.43 |
| 115200 | 8.7 | 2.21 |

21.6.4.11 Receiver Time-out

The Time-out Value field in the Receiver Time-out Register (RTOR.TO) enables handling of variable-length frames by detection of selectable idle durations on the RXD line. The value written to TO is loaded to a decremental counter, and unless it is zero, a time-out will occur when the amount of inactive bit periods match the initial counter value. If a time-out has not occurred, the counter will reload and restart every time a new character arrives. A time-out sets the TIMEOUT bit in CSR. Clearing TIMEOUT can be done in two ways:

- Writing a one to the Start Time-out bit (CR.STTTO). This also aborts count down until the next character has been received.
- Writing a one to the Reload and Start Time-out bit (CR.RETTO). This also reloads the counter and restarts count down immediately.

Figure 21-23. Receiver Time-out Block Diagram

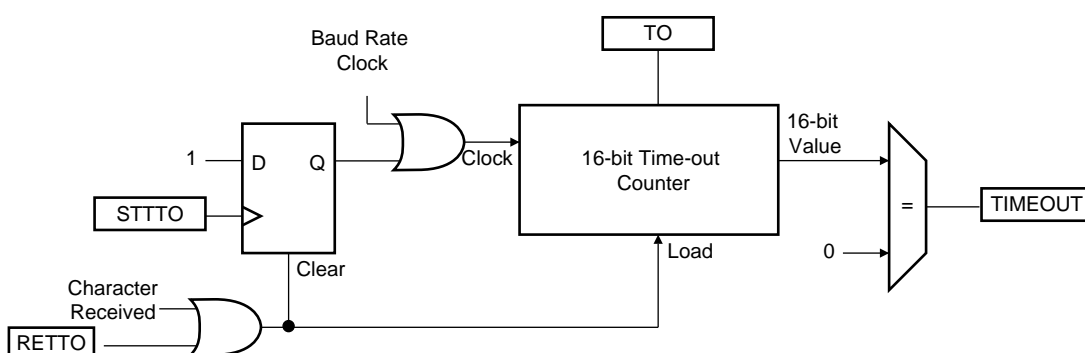

Table 21-9. Maximum Time-out Period

| Baud Rate (bit/sec) | Bit Time (μs) | Time-out (ms) |
|---------------------|---------------|---------------|
| 600 | 1 667 | 109 225 |
| 1 200 | 833 | 54 613 |
| 2 400 | 417 | 27 306 |
| 4 800 | 208 | 13 653 |
| 9 600 | 104 | 6 827 |
| 14400 | 69 | 4 551 |
| 19200 | 52 | 3 413 |
| 28800 | 35 | 2 276 |
| 33400 | 30 | 1 962 |
| 56000 | 18 | 1 170 |
| 57600 | 17 | 1 138 |
| 200000 | 5 | 328 |

21.6.4.12 Framing Error

The receiver is capable of detecting framing errors. A framing error has occurred if a stop bit reads as zero. This can occur if the transmitter and receiver are not synchronized. A framing error is reported by CSR.FRAME as soon as the error is detected, at the middle of the stop bit.

Figure 21-24. Framing Error Status

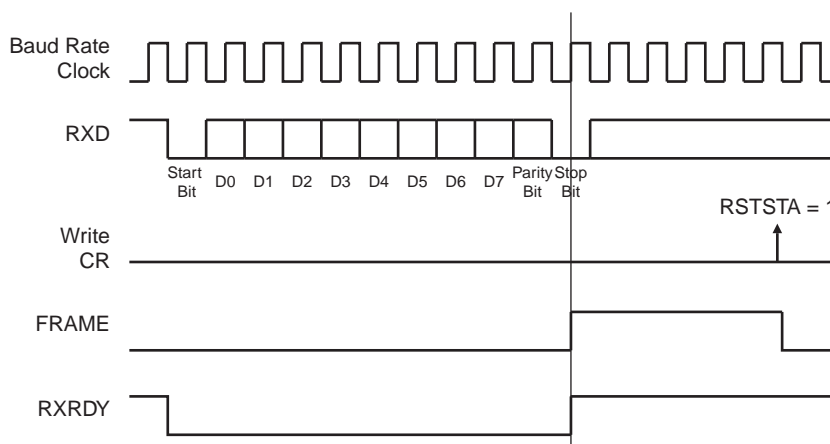

21.6.4.13 Transmit Break

When CSR.TXRDY is set, the user can request the transmitter to generate a break condition on the TXD line by writing a one to The Start Break bit (CR.STTBRK). The break is treated as a normal 0x00 character transmission, clearing CSR.TXRDY and CSR.TXEMPTY, but with zeroes for preambles, start, parity, stop, and time guard bits. Writing a one to the Stop Break bit (CR.STPBRK) will stop the generation of new break characters, and send ones for TG duration or at least 12 bit periods, ensuring that the receiver detects end of break, before resuming normal operation. Figure 21-25 illustrates STTBRK and STPBRK effect on the TXD line.

Writing to CR.STTBRK and CR.STPBRK simultaneously can lead to unpredictable results. Writes to THR before a pending break has started will be ignored.

Figure 21-25. Break Transmission

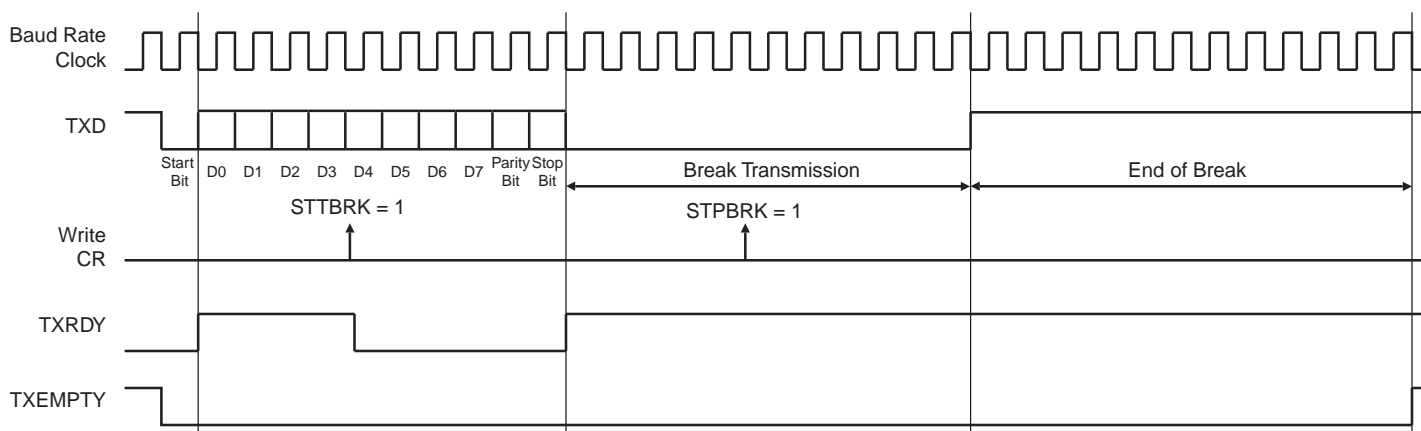

21.6.4.14 Receive Break

A break condition is assumed when incoming data, parity, and stop bits are zero. This corresponds to a framing error, but FRAME will remain zero while the Break Received/End Of Break

bit (CSR.RXBRK) is set. Writing a one to CR.RSTSTA will clear CSR.RXBRK. An end of break will also set CSR.RXBRK, and is assumed when TX is high for at least 2/16 of a bit period in asynchronous mode, or when a high level is sampled in synchronous mode.

21.6.4.15 Hardware Handshaking

The USART features an out-of-band hardware handshaking flow control mechanism, implementable by connecting the RTS and CTS pins with the remote device, as shown in [Figure 21-26](#).

Figure 21-26. Connection with a Remote Device for Hardware Handshaking



Writing 0x2 to the MR.MODE field configures the USART to operate in this mode. The receiver will drive its RTS pin high when disabled or when the Reception Buffer Full bit (CSR.RXBUFF) is set by the Buffer Full signal from the Peripheral DMA controller. If the receiver's RTS pin is high, the transmitter's CTS pin will also be high and only the active character transactions will be completed. Allocating a new buffer to the DMA controller by clearing RXBUFF, will drive the RTS pin low, allowing the transmitter to resume transmission. Detected level changes on the CTS pin can trigger interrupts, and are reported by the CTS Input Change bit in the Channel Status Register (CSR.CTSIC).

[Figure 21-27](#) illustrates receiver functionality, and [Figure 21-28](#) illustrates transmitter functionality.

Figure 21-27. Receiver Behavior when Operating with Hardware Handshaking

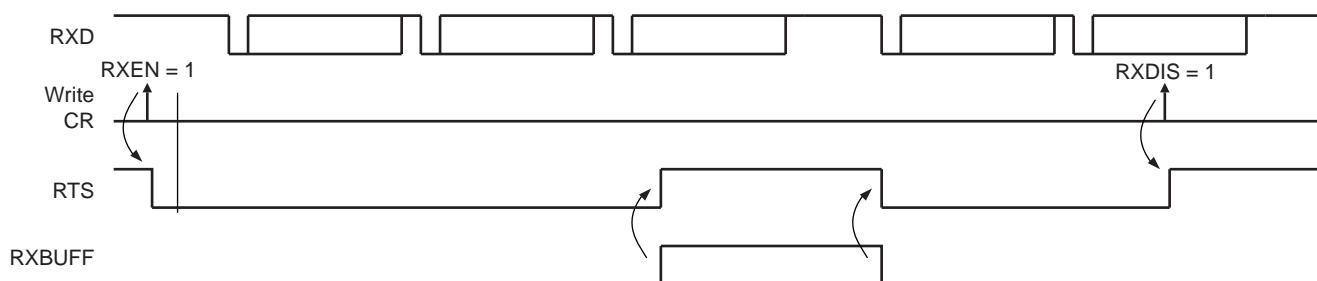

Figure 21-28. Transmitter Behavior when Operating with Hardware Handshaking



21.6.5 ISO7816 Mode

The USART features an ISO7816-compatible mode, enabling interfacing with smart cards and Security Access Modules (SAM) through an ISO7816 compliant link. T=0 and T=1 protocols, as defined in the ISO7816 standard, are supported by writing 0x4 and 0x6 respectively to MR.MODE.

21.6.5.1 ISO7816 Mode Overview

ISO7816 specifies half duplex communication on one bidirectional line. The baud rate is a fraction of the clock provided by the master on the CLK pin (see "Baud Rate Generator" on page 300). The USART connects to a smart card as shown in Figure 21-29. The TXD pin is bidirectional and is routed to the receiver when the transmitter is disabled. Having both receiver and transmitter enabled simultaneously may lead to unpredictable results.

Figure 21-29. USART (master) Connected to a Smart Card

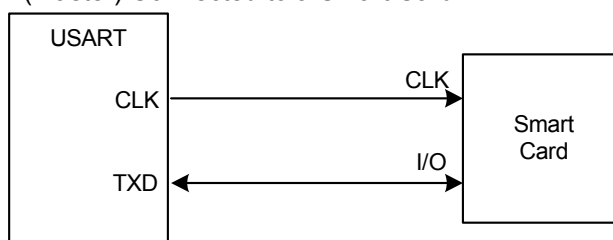

In both T=0 and T=1 modes, the character format is fixed to eight data bits, and one or two stop bits, regardless of CHRL, MODE9, and CHMODE values. Parity according to specification is even. If the inverse transmission format is used, where payload data bits are transmitted inverted on the I/O line, the user can use odd parity and perform an XOR on data headed to THR and coming from RHR.

21.6.5.2 Protocol T=0

In T=0 protocol, a character is made up of one start bit, eight data bits, one parity bit, and a two bit period guard time. During the guard time, the line will be high if the receiver does not signal a parity error, as shown in Figure 21-30. The receiver signals a parity error, aka non-acknowledge (NACK), by pulling the line low for a bit period within the guard time, resulting in the total character length being incremented by one, see Figure 21-31. The USART will not load data to RHR if it detects a parity error, and will set PARE if it receives a NACK.

Figure 21-30. T=0 Protocol without Parity Error

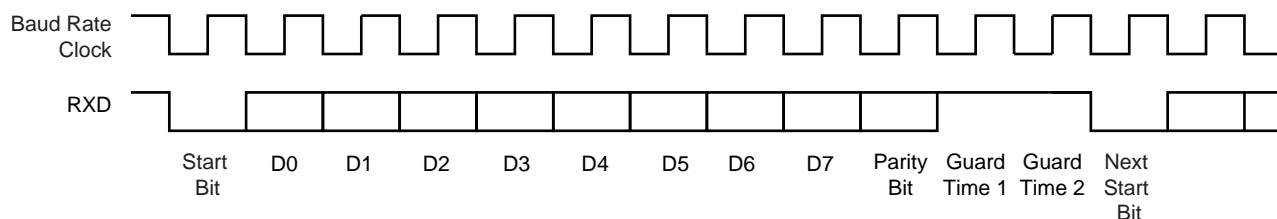
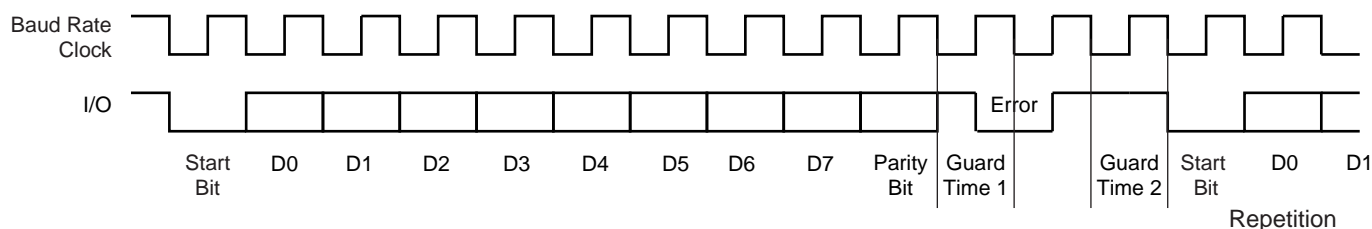

Figure 21-31. T=0 Protocol with Parity Error



21.6.5.3 Protocol T=1

In T=1 protocol, the character resembles an asynchronous format with only one stop bit. The parity is generated when transmitting and checked when receiving. Parity errors set PARE.

21.6.5.4 Receive Error Counter

The USART receiver keeps count of up to 255 errors in the Number Of Errors field in the Number of Error Register (NER.NB_ERRORS). Reading NER automatically clears NB_ERRORS.

21.6.5.5 Receive NACK Inhibit

The USART can be configured to ignore parity errors by writing a one to the Inhibit Non Acknowledge bit (MR.INACK). Erroneous characters will be treated as if they were ok, not generating a NACK, loaded to RHR, and raising RXRDY.

21.6.5.6 Transmit Character Repetition

The USART can be configured to automatically re-send a character if it receives a NACK. Writing a value other than zero to MR.MAX_ITERATION will enable and determine the number of consecutive re-transmissions. If the number of unsuccessful re-transmissions equal MAX_ITERATION, the iteration bit (CSR.ITER) is set. Writing a one to the Reset Iteration bit (CR.RSTIT) will clear ITER.

21.6.5.7 Disable Successive Receive NACK

The receiver can limit the number of consecutive NACK's to the value in MAX_ITERATION. This is enabled by writing a one to the Disable Successive NACK bit (MR.DSNACK). If the number of NACK's is about to surpass MAX_ITERATION, the character will instead be accepted as valid and ITER is set.

21.6.6 IrDA Mode

The USART features an IrDA mode, supporting asynchronous, half-duplex, point-to-point wireless communication. It embeds the modulator and demodulator, allowing for a glueless connection to the infrared transceivers, as shown in [Figure 21-32](#). Writing 0x8 to MR.MODE enables this mode, and activates the IrDA specification v1.1 compliant modem. Data transfer speeds ranging from 2.4Kbit/s to 115.2Kbit/s are supported and the character format is fixed to one start bit, eight data bits, and one stop bit.

Figure 21-32. Connection to IrDA Transceivers

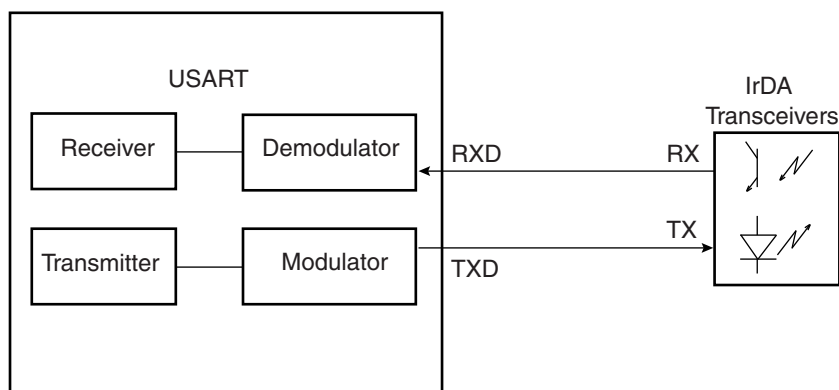

The receiver and the transmitter must be exclusively enabled or disabled, according to the direction of the transmission. To receive IrDA signals, the following needs to be done:

- Disable TX and enable RX.
- Configure the TXD pin as an I/O, outputting zero to avoid LED activation. Disable the internal pull-up for improved power consumption.
- Receive data.

21.6.6.1 IrDA Modulation

The RZI modulation scheme is used, where a zero is represented by a light pulse one 3/16th of a bit period, and no pulse to represent a one. Some examples of signal pulse duration are shown in [Table 21-10](#).

Table 21-10. IrDA Pulse Duration

| Baud Rate | Pulse Duration (3/16) |
|--------------|-----------------------|
| 2.4 Kbit/s | 78.13 μ s |
| 9.6 Kbit/s | 19.53 μ s |
| 19.2 Kbit/s | 9.77 μ s |
| 38.4 Kbit/s | 4.88 μ s |
| 57.6 Kbit/s | 3.26 μ s |
| 115.2 Kbit/s | 1.63 μ s |

[Figure 21-33](#) shows an example of character transmission.

Figure 21-33. IrDA Modulation

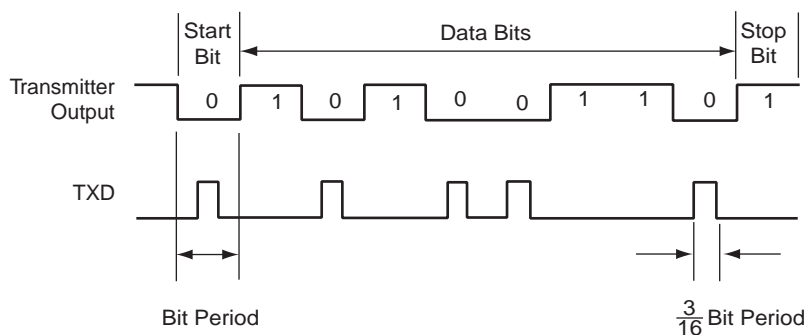

21.6.6.2 IrDA Baud Rate

As the IrDA mode shares some logic with the ISO7816 mode, the FIDI.FI_DI_RATIO field needs to be configured correctly. See Section “21.6.2.5” on page 302. Table 21-11 gives some examples of BRGR.CD values, baud rate error, and pulse duration. Note that the maximal acceptable error rate of $\pm 1.87\%$ must be met.

Table 21-11. IrDA Baud Rate Error

| Peripheral Clock | Baud Rate | CD | Baud Rate Error | Pulse Time |
|------------------|-----------|-----|-----------------|------------|
| 3 686 400 | 115 200 | 2 | 0.00% | 1.63 |
| 20 000 000 | 115 200 | 11 | 1.38% | 1.63 |
| 32 768 000 | 115 200 | 18 | 1.25% | 1.63 |
| 40 000 000 | 115 200 | 22 | 1.38% | 1.63 |
| 3 686 400 | 57 600 | 4 | 0.00% | 3.26 |
| 20 000 000 | 57 600 | 22 | 1.38% | 3.26 |
| 32 768 000 | 57 600 | 36 | 1.25% | 3.26 |
| 40 000 000 | 57 600 | 43 | 0.93% | 3.26 |
| 3 686 400 | 38 400 | 6 | 0.00% | 4.88 |
| 20 000 000 | 38 400 | 33 | 1.38% | 4.88 |
| 32 768 000 | 38 400 | 53 | 0.63% | 4.88 |
| 40 000 000 | 38 400 | 65 | 0.16% | 4.88 |
| 3 686 400 | 19 200 | 12 | 0.00% | 9.77 |
| 20 000 000 | 19 200 | 65 | 0.16% | 9.77 |
| 32 768 000 | 19 200 | 107 | 0.31% | 9.77 |
| 40 000 000 | 19 200 | 130 | 0.16% | 9.77 |
| 3 686 400 | 9 600 | 24 | 0.00% | 19.53 |
| 20 000 000 | 9 600 | 130 | 0.16% | 19.53 |
| 32 768 000 | 9 600 | 213 | 0.16% | 19.53 |
| 40 000 000 | 9 600 | 260 | 0.16% | 19.53 |

Table 21-11. IrDA Baud Rate Error (Continued)

| Peripheral Clock | Baud Rate | CD | Baud Rate Error | Pulse Time |
|------------------|-----------|-----|-----------------|------------|
| 3 686 400 | 2 400 | 96 | 0.00% | 78.13 |
| 20 000 000 | 2 400 | 521 | 0.03% | 78.13 |
| 32 768 000 | 2 400 | 853 | 0.04% | 78.13 |

21.6.6.3 IrDA Demodulator

The demodulator depends on an 8-bit down counter loaded with the value in IRDA_Filter field in the IrDA Filter Register (IFR.IRDA_FILTER). When a falling edge on RXD is detected, the counter starts decrementing at CLK_USART speed. If a rising edge is detected on RXD, the counter stops and is reloaded with the IFR value. If no rising edge has been detected when the counter reaches zero, the receiver input is pulled low during one bit period. See [Figure 21-34](#). Writing a one to the Infrared Receive Line Filter bit (MR.FILTER), enables a noise filter that, instead of using just one sample, will choose the majority value from three consecutive samples.

Figure 21-34. IrDA Demodulator Operations

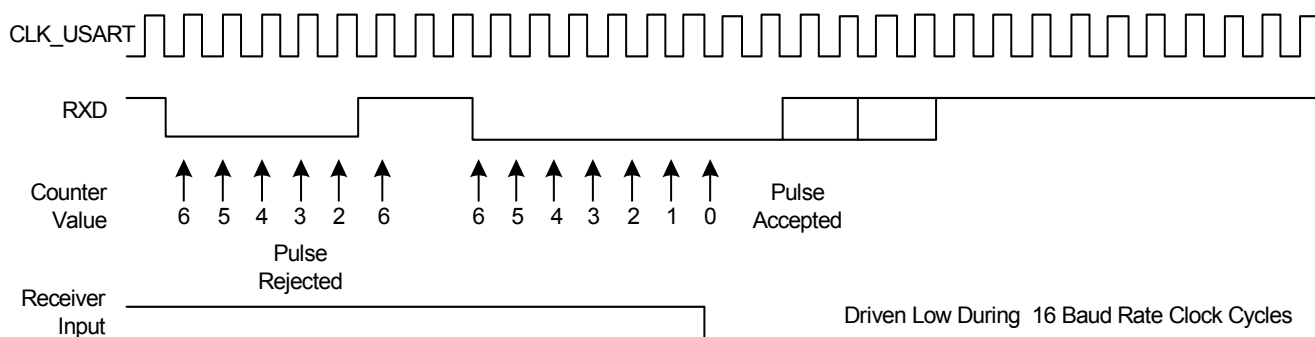

21.6.7 RS485 Mode

The USART features an RS485 mode, supporting line driver control. This supplements normal synchronous and asynchronous mode by driving the RTS pin high when the transmitter is operating. The RTS pin level is the inverse of the CSR.TXEMPTY value. Writing 0x1 to MR.MODE enables this mode. A typical connection to a RS485 bus is shown in [Figure 21-35](#).

Figure 21-35. Typical Connection to a RS485 Bus

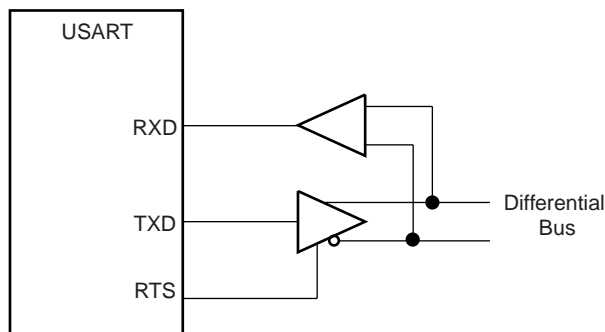

If a timeguard has been configured the RTS pin will remain high for the duration specified in TG, as shown in [Figure 21-36](#).

Figure 21-36. Example of RTS Drive with Timeguard Enabled

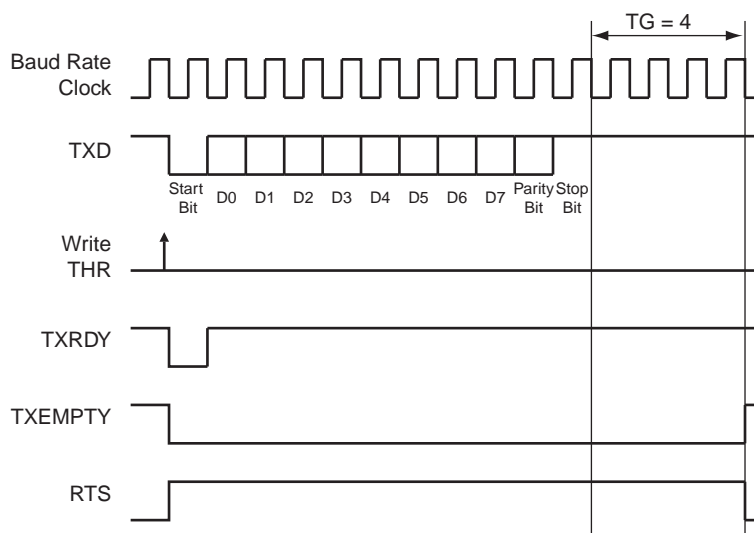

21.6.8 Modem Mode

The USART features a modem mode, supporting asynchronous communication with the following signal pins: Data Terminal Ready (DTR), Data Set Ready (DSR), Request to Send (RTS), Clear to Send (CTS), Data Carrier Detect (DCD), and Ring Indicator (RI). Writing 0x3 to MR.MODE enables this mode, and the USART will behave as a Data Terminal Equipment (DTE), controlling DTR and RTS, whilst detecting level changes on DSR, DCD, CTS, and RI.

Table 21-12 shows USART signal pins with the corresponding standardized modem connections.

Table 21-12. Circuit References

| USART Pin | V.24 | CCITT | Direction |
|-----------|------|-------|------------------------|
| TXD | 2 | 103 | From terminal to modem |
| RTS | 4 | 105 | From terminal to modem |
| DTR | 20 | 108.2 | From terminal to modem |
| RXD | 3 | 104 | From modem to terminal |
| CTS | 5 | 106 | From terminal to modem |
| DSR | 6 | 107 | From terminal to modem |
| DCD | 8 | 109 | From terminal to modem |
| RI | 22 | 125 | From terminal to modem |

The DTR pin is controlled by writing a one to the DTR enable and disable bits (DTREN, DTRDIS) in CR. It is low when enabled, and high when disabled. The RTS pin is controlled automatically.

Detected level changes can trigger interrupts, and are reported by the respective Input Change bits (RIIC, DSRIC, DCDIC, and CTSIC) in CSR. These status bits are automatically cleared when CSR is read. When the CTS pin goes high, the USART will wait for the transmitter to complete any ongoing character transmission before automatically disabling it.

21.6.9 SPI Mode

The USART features a Serial Peripheral Interface (SPI) link compliant mode, supporting synchronous, full-duplex communication, in both master and slave mode. Writing 0xE (master) or 0xF (slave) to MR.MODE will enable this mode. A SPI in master mode controls the data flow to and from the other SPI devices, who are in slave mode. It is possible to let devices take turns being masters (aka multi-master protocol), and one master may shift data simultaneously into several slaves, but only one slave may respond at a time. A slave is selected when its slave select (NSS) signal has been raised by the master. The USART can only generate one NSS signal, and it is possible to use standard I/O lines to address more than one slave.

21.6.9.1 Modes of Operation

The SPI system consists of two data lines and two control lines:

- Master Out Slave In (MOSI): This line supplies the data shifted from master to slave. In master mode this is connected to TXD, and in slave mode to RXD.
- Master In Slave Out (MISO): This line supplies the data shifted from slave to master. In master mode this is connected to RXD, and in slave mode to TXD.
- Serial Clock (CLK): This is controlled by the master. One period per bit transmission. In both modes this is connected to CLK.
- Slave Select (NSS): This control line allows the master to select or deselect a slave. In master mode this is connected to RTS, and in slave mode to CTS.

Changing SPI mode after initial configuration has to be followed by a transceiver software reset in order to avoid unpredictable behavior.

21.6.9.2 Baud Rate

The baud rate generator operates as described in ["Baud Rate in Synchronous and SPI Mode" on page 302](#), with the following requirements:

In SPI Master Mode:

- The Clock Selection field (MR.USCLKS) must not equal 0x3 (external clock, CLK).
- The Clock Output Select bit (MR.CLKO) must be one.
- The BRGR.CD field must be at least 0x4.
- If USCLKS is one (internal divided clock, CLK_USART/DIV), the value in CD has to be even, ensuring a 50:50 duty cycle. CD can be odd if USCLKS is zero (internal clock, CLK_USART).

In SPI Slave Mode:

- CLK frequency must be at least four times lower than the system clock.

21.6.9.3 Data Transfer

Up to nine data bits are successively shifted out on the TXD pin at each edge. There are no start, parity, or stop bits, and MSB is always sent first. The SPI Clock Polarity (MR.CPOL), and SPI Clock Phase (MR.CPHA) bits configure CLK by selecting the edges upon which bits are shifted and sampled, resulting in four non-interoperable protocol modes, see [Table 21-13](#). If MR.CPOL is zero, the inactive state value of CLK is logic level zero, and if MR.CPOL is one, the inactive state value of CLK is logic level one. If MR.CPHA is zero, data is changed on the leading edge of CLK, and captured on the following edge of CLK. If MR.CPHA is one, data is captured on the leading edge of CLK, and changed on the following edge of CLK. A master/slave pair must use the same configuration, and the master must be reconfigured if it is to communicate with slaves using different configurations. See [Figures 21-37 and 21-38](#).

Table 21-13. SPI Bus Protocol Modes

| SPI Bus Protocol Mode | CPOL | CPHA |
|-----------------------|------|------|
| 0 | 0 | 1 |
| 1 | 0 | 0 |
| 2 | 1 | 1 |
| 3 | 1 | 0 |

Figure 21-37. SPI Transfer Format (CPHA=1, 8 bits per transfer)

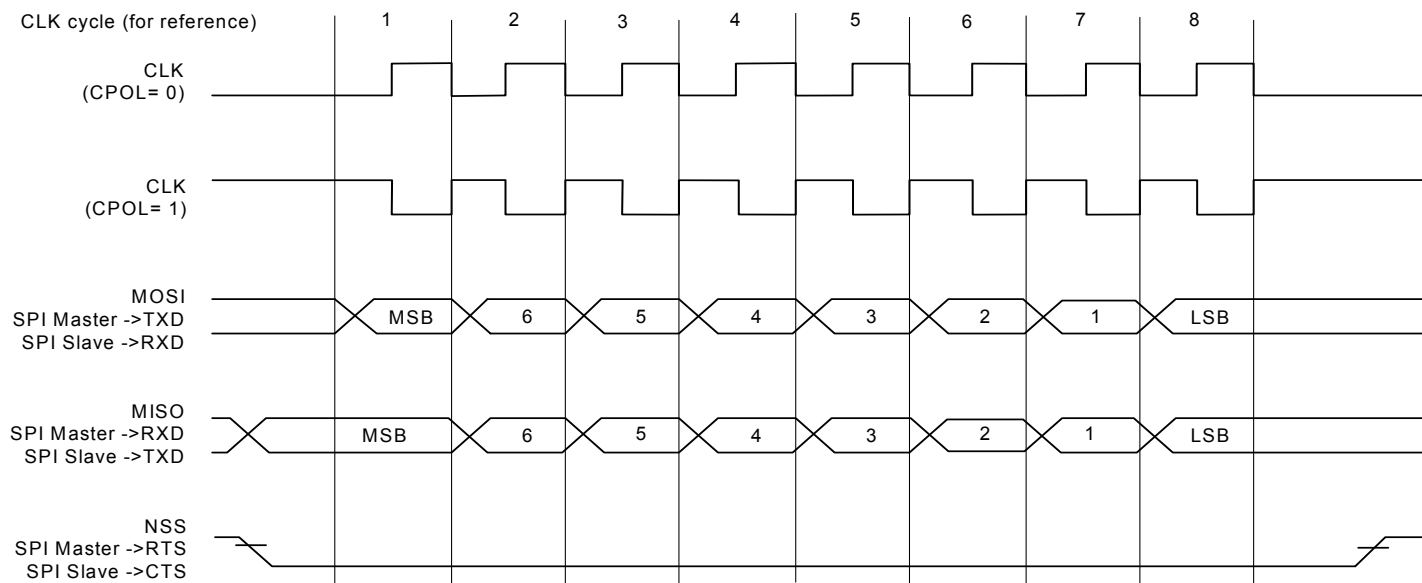
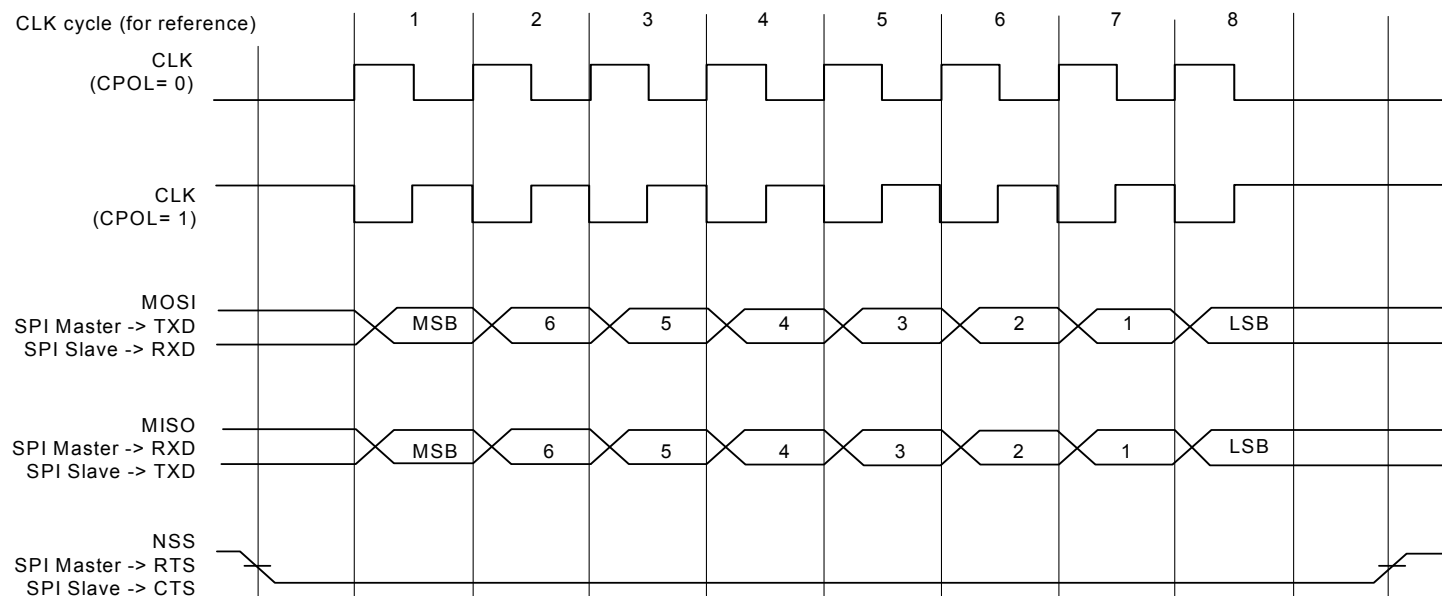

Figure 21-38. SPI Transfer Format (CPHA=0, 8 bits per transfer)



21.6.9.4 Receiver and Transmitter Control

See ["Transmitter Operations"](#) on page 304, and ["Receiver Operations"](#) on page 311.

21.6.9.5 Character Transmission and Reception

In SPI master mode, the slave select line (NSS) is asserted low one bit period before the start of transmission, and released high one bit period after every character transmission. A delay for at least three bit periods is always inserted in between characters. In order to address slave devices supporting the Chip Select Active After Transfer (CSAAT) mode, NSS can be forced low by writing a one to the Force SPI Chip Select bit (CR.RTSN/FCS). Releasing NSS when FCS is one, is only possible by writing a one to the Release SPI Chip Select bit (CR.RTSDIS/RCS).

In SPI slave mode, a low level on NSS for at least one bit period will allow the slave to initiate a transmission or reception. The Underrun Error bit (CSR.UNRE) is set if a character must be sent while THR is empty, and TXD will be high during character transmission, as if 0xFF was being sent. If a new character is written to THR it will be sent correctly during the next transmission slot. Writing a one to CR.RSTSTA will clear CSR.UNRE. To ensure correct behavior of the receiver in SPI slave mode, the master device sending the frame must ensure a minimum delay of one bit period in between each character transmission.

21.6.9.6 Receiver Time-out

Receiver Time-out's are not possible in SPI mode as the baud rate clock is only active during data transfers.

21.6.10

21.6.11 Test Modes

The internal loopback feature enables on-board diagnostics, and allows the USART to operate in three different test modes, with reconfigured pin functionality, as shown below.

21.6.11.1 Normal Mode

During normal operation, a receivers RXD pin is connected to a transmitters TXD pin.

Figure 21-39. Normal Mode Configuration

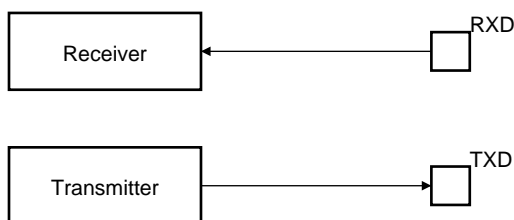

21.6.11.2 Automatic Echo Mode

Automatic echo mode allows bit-by-bit retransmission. When a bit is received on the RXD pin, it is also sent to the TXD pin, as shown in [Figure 21-40](#). Transmitter configuration has no effect.

Figure 21-40. Automatic Echo Mode Configuration

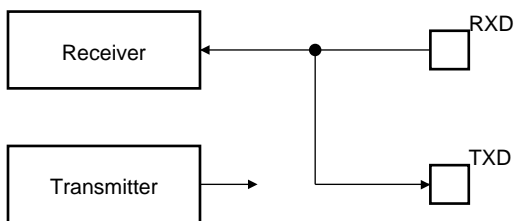

21.6.11.3 *Local Loopback Mode*

Local loopback mode connects the output of the transmitter directly to the input of the receiver, as shown in [Figure 21-41](#). The TXD and RXD pins are not used. The RXD pin has no effect on the receiver and the TXD pin is continuously driven high, as in idle state.

Figure 21-41. Local Loopback Mode Configuration

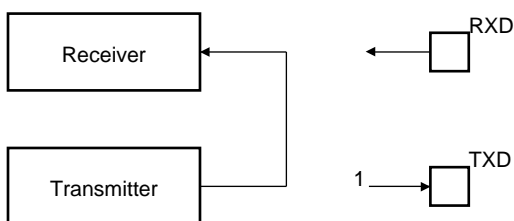

21.6.11.4 *Remote Loopback Mode*

Remote loopback mode connects the RXD pin to the TXD pin, as shown in [Figure 21-42](#). The transmitter and the receiver are disabled and have no effect. This mode allows bit-by-bit retransmission.

Figure 21-42. Remote Loopback Mode Configuration

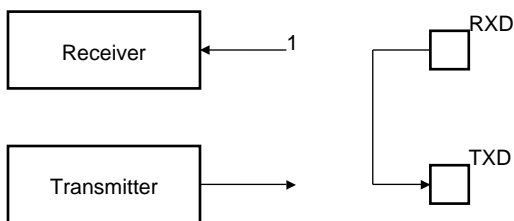

21.7 User Interface

Table 21-14. USART Register Memory Map

| Offset | Register | Name | Access | Reset |
|--------|-----------------------------------|---------|------------|-------------------|
| 0x0000 | Control Register | CR | Write-only | 0x00000000 |
| 0x0004 | Mode Register | MR | Read-write | 0x00000000 |
| 0x0008 | Interrupt Enable Register | IER | Write-only | 0x00000000 |
| 0x000C | Interrupt Disable Register | IDR | Write-only | 0x00000000 |
| 0x0010 | Interrupt Mask Register | IMR | Read-only | 0x00000000 |
| 0x0014 | Channel Status Register | CSR | Read-only | 0x00000000 |
| 0x0018 | Receiver Holding Register | RHR | Read-only | 0x00000000 |
| 0x001C | Transmitter Holding Register | THR | Write-only | 0x00000000 |
| 0x0020 | Baud Rate Generator Register | BRGR | Read-write | 0x00000000 |
| 0x0024 | Receiver Time-out Register | RTOR | Read-write | 0x00000000 |
| 0x0028 | Transmitter Timeguard Register | TTGR | Read-write | 0x00000000 |
| 0x0040 | FI DI Ratio Register | FIDI | Read-write | 0x00000174 |
| 0x0044 | Number of Errors Register | NER | Read-only | 0x00000000 |
| 0x004C | IrDA Filter Register | IFR | Read-write | 0x00000000 |
| 0x0050 | Manchester Configuration Register | MAN | Read-write | 0x30011004 |
| 0x00FC | Version Register | VERSION | Read-only | 0x ⁽¹⁾ |

Note: 1. Values in the Version Register vary with the version of the IP block implementation.

21.7.1 Control Register

Name: CR
Access Type: Write-only
Offset: 0x0
Reset Value: 0x00000000

| | | | | | | | |
|-------|---------|-------|-------|------------|-----------|--------|--------|
| 31 | 30 | 29 | 28 | 27 | 26 | 25 | 24 |
| – | – | – | – | – | – | – | – |
| 23 | 22 | 21 | 20 | 19 | 18 | 17 | 16 |
| – | – | – | – | RTSDIS/RCS | RTSEN/FCS | DTRDIS | DTREN |
| 15 | 14 | 13 | 12 | 11 | 10 | 9 | 8 |
| RETTO | RSTNACK | RSTIT | SENDA | STTTO | STPBRK | STTBRK | RSTSTA |
| 7 | 6 | 5 | 4 | 3 | 2 | 1 | 0 |
| TXDIS | TXEN | RXDIS | RXEN | RSTTX | RSTRX | – | – |

- RTSDIS/RCS: Request to Send Disable/Release SPI Chip Select**
 Writing a zero to this bit has no effect.
 Writing a one to this bit when USART is not in SPI master mode drives RTS pin high.
 Writing a one to this bit when USART is in SPI master mode releases NSS (RTS pin).
- RTSEN/FCS: Request to Send Enable/Force SPI Chip Select**
 Writing a zero to this bit has no effect.
 Writing a one to this bit when USART is not in SPI master mode drives RTS low.
 Writing a one to this bit when USART is in SPI master mode when;
 FCS=0: has no effect.
 FCS=1: forces NSS (RTS pin) low, even if USART is not transmitting, in order to address SPI slave devices supporting the CSAAT Mode (Chip Select Active After Transfer).
- DTRDIS: Data Terminal Ready Disable**
 Writing a zero to this bit has no effect.
 Writing a one to this bit drives DTR pin high.
- DTREN: Data Terminal Ready Enable**
 Writing a zero to this bit has no effect.
 Writing a one to this bit drives DTR pin low.
- RETTO: Rearm Time-out**
 Writing a zero to this bit has no effect.
 Writing a one to this bit reloads the time-out counter and clears CSR.TIMEOUT.
- RSTNACK: Reset Non Acknowledge**
 Writing a zero to this bit has no effect.
 Writing a one to this bit clears CSR.NACK.
- RSTIT: Reset Iterations**
 Writing a zero to this bit has no effect.
 Writing a one to this bit clears CSR.ITER if ISO7816 is enabled in MR.MODE
- SENDA: Send Address**
 Writing a zero to this bit has no effect.
 Writing a one to this bit will in multidrop mode send the next character written to THR as an address.

- **STTTO: Start Time-out**
 - Writing a zero to this bit has no effect.
 - Writing a one to this bit will abort any current time-out count down, and trigger a new count down when the next character has been received. CSR.TIMEOUT is also cleared.
- **STPBRK: Stop Break**
 - Writing a zero to this bit has no effect.
 - Writing a one to this bit will stop the generation of break signal characters, and then send ones for TTGR.TG duration, or at least 12 bit periods. No effect if no break is being transmitted.
- **STTBRK: Start Break**
 - Writing a zero to this bit has no effect.
 - Writing a one to this bit will start transmission of break characters when current characters present in THR and the transmit shift register have been sent. No effect if a break signal is already being generated. CSR.TXRDY and CSR.TXEMPTY will be cleared.
- **RSTSTA: Reset Status Bits**
 - Writing a zero to this bit has no effect.
 - Writing a one to this bit will clear the following bits in CSR: PARE, FRAME, OVRE, MANERR, UNRE, and RXBRK.
- **TXDIS: Transmitter Disable**
 - Writing a zero to this bit has no effect.
 - Writing a one to this bit disables the transmitter.
- **TXEN: Transmitter Enable**
 - Writing a zero to this bit has no effect.
 - Writing a one to this bit enables the transmitter if TXDIS is zero.
- **RXDIS: Receiver Disable**
 - Writing a zero to this bit has no effect.
 - Writing a one to this bit disables the receiver.
- **RXEN: Receiver Enable**
 - Writing a zero to this bit has no effect.
 - Writing a one to this bit enables the receiver if RXDIS is zero.
- **RSTTX: Reset Transmitter**
 - Writing a zero to this bit has no effect.
 - Writing a one to this bit will reset the transmitter.
- **RSTRX: Reset Receiver**
 - Writing a zero to this bit has no effect.
 - Writing a one to this bit will reset the receiver.

21.7.2 Mode Register

Name: MR
Access Type: Read-write
Offset: 0x4
Reset Value: 0x00000000

| | | | | | | | |
|--------|----------|--------|--------|------|---------------|-------|-----------|
| 31 | 30 | 29 | 28 | 27 | 26 | 25 | 24 |
| ONEBIT | MODSYNC | MAN | FILTER | – | MAX_ITERATION | | |
| 23 | 22 | 21 | 20 | 19 | 18 | 17 | 16 |
| – | VAR_SYNC | DSNACK | INACK | OVER | CLKO | MODE9 | MSBF/CPOL |
| 15 | 14 | 13 | 12 | 11 | 10 | 9 | 8 |
| CHMODE | | NBSTOP | | PAR | | | SYNC/CPHA |
| 7 | 6 | 5 | 4 | 3 | 2 | 1 | 0 |
| CHRL | | USCLKS | | MODE | | | |

- **ONEBIT: Start Frame Delimiter Selector**
 - 0: The start frame delimiter is a command or data sync, as defined by MODSYNC.
 - 1: The start frame delimiter is a normal start bit, as defined by MODSYNC.
- **MODSYNC: Manchester Synchronization Mode**
 - 0: The manchester start bit is either a 0-to-1 transition, or a data sync.
 - 1: The manchester start bit is either a 1-to-0 transition, or a command sync.
- **MAN: Manchester Encoder/Decoder Enable**
 - 0: Manchester endec is disabled.
 - 1: Manchester endec is enabled.
- **FILTER: Infrared Receive Line Filter**
 - 0: The USART does not filter the receive line.
 - 1: The USART filters the receive line by doing three consecutive samples and uses the majority value.
- **MAX_ITERATION**
 - This field determines the number of acceptable consecutive NACK's when in protocol T=0.
- **VAR_SYNC: Variable Synchronization of Command/Data Sync Start Frame Delimiter**
 - 0: Sync pattern according to MODSYNC.
 - 1: Sync pattern according to THR.TXSYNH.
- **DSNACK: Disable Successive NACK**
 - 0: NACK's are handled as normal, unless disabled by INACK.
 - 1: The receiver restricts the amount of consecutive NACK's by MAX_ITERATION value. If MAX_ITERATION=0 no NACK will be issued and the first erroneous message is accepted as a valid character, setting CSR.ITER.
- **INACK: Inhibit Non Acknowledge**
 - 0: The NACK is generated.
 - 1: The NACK is not generated.
- **OVER: Oversampling Mode**
 - 0: Oversampling at 16 times the baud rate.
 - 1: Oversampling at 8 times the baud rate.
- **CLKO: Clock Output Select**
 - 0: The USART does not drive the CLK pin.
 - 1: The USART drives the CLK pin unless USCLKS selects the external clock.
- **MODE9: 9-bit Character Length**
 - 0: CHRL defines character length.

1: 9-bit character length.

- **MSBF/CPOL: Bit Order or SPI Clock Polarity**

If USART does not operate in SPI Mode:

MSBF=0: Least Significant Bit is sent/received first.

MSBF=1: Most Significant Bit is sent/received first.

If USART operates in SPI Mode, CPOL is used with CPHA to produce the required clock/data relationship between devices.

CPOL=0: The inactive state value of CLK is logic level zero.

CPOL=1: The inactive state value of CLK is logic level one.

- **CHMODE: Channel Mode**

Table 21-15.

| CHMODE | | Mode Description |
|--------|---|--|
| 0 | 0 | Normal Mode |
| 0 | 1 | Automatic Echo. Receiver input is connected to the TXD pin. |
| 1 | 0 | Local Loopback. Transmitter output is connected to the Receiver input. |
| 1 | 1 | Remote Loopback. RXD pin is internally connected to the TXD pin. |

- **NBSTOP: Number of Stop Bits**

Table 21-16.

| NBSTOP | | Asynchronous (SYNC=0) | Synchronous (SYNC=1) |
|--------|---|-----------------------|----------------------|
| 0 | 0 | 1 stop bit | 1 stop bit |
| 0 | 1 | 1.5 stop bits | Reserved |
| 1 | 0 | 2 stop bits | 2 stop bits |
| 1 | 1 | Reserved | Reserved |

- **PAR: Parity Type**

Table 21-17.

| PAR | | | Parity Type |
|-----|---|---|----------------------------|
| 0 | 0 | 0 | Even parity |
| 0 | 0 | 1 | Odd parity |
| 0 | 1 | 0 | Parity forced to 0 (Space) |
| 0 | 1 | 1 | Parity forced to 1 (Mark) |
| 1 | 0 | x | No parity |
| 1 | 1 | x | Multidrop mode |

- **SYNC/CPHA: Synchronous Mode Select or SPI Clock Phase**

If USART does not operate in SPI Mode (MODE is ... 0xE and 0xF):

SYNC = 0: USART operates in Asynchronous Mode.

SYNC = 1: USART operates in Synchronous Mode.

If USART operates in SPI Mode, CPHA determines which edge of CLK causes data to change and which edge causes data to be captured. CPHA is used with CPOL to produce the required clock/data relationship between master and slave devices.

CPHA = 0: Data is changed on the leading edge of CLK and captured on the following edge of CLK.

CPHA = 1: Data is captured on the leading edge of CLK and changed on the following edge of CLK.

- **CHRL: Character Length.**

Table 21-18.

| CHRL | | Character Length |
|------|---|------------------|
| 0 | 0 | 5 bits |
| 0 | 1 | 6 bits |
| 1 | 0 | 7 bits |
| 1 | 1 | 8 bits |

- **USCLKS: Clock Selection**

Table 21-19.

| USCLKS | | Selected Clock |
|--------|---|------------------------------|
| 0 | 0 | CLK_USART |
| 0 | 1 | CLK_USART/DIV ⁽¹⁾ |
| 1 | 0 | Reserved |
| 1 | 1 | CLK |

Note: 1. The value of DIV is device dependent. Please refer to the Module Configuration section at the end of this chapter.

- **MODE**

Table 21-20.

| MODE | | | | Mode of the USART |
|--------|---|---|---|-------------------------|
| 0 | 0 | 0 | 0 | Normal |
| 0 | 0 | 0 | 1 | RS485 |
| 0 | 0 | 1 | 0 | Hardware Handshaking |
| 0 | 0 | 1 | 1 | Modem |
| 0 | 1 | 0 | 0 | IS07816 Protocol: T = 0 |
| 0 | 1 | 1 | 0 | IS07816 Protocol: T = 1 |
| 1 | 0 | 0 | 0 | IrDA |
| 1 | 1 | 1 | 0 | SPI Master |
| 1 | 1 | 1 | 1 | SPI Slave |
| Others | | | | Reserved |

21.7.3 Interrupt Enable Register

Name: IER
Access Type: Write-only
Offset: 0x8
Reset Value: 0x00000000

| | | | | | | | |
|------|-------|------|----------|-------|-----------|---------|---------|
| 31 | 30 | 29 | 28 | 27 | 26 | 25 | 24 |
| – | – | – | – | – | – | – | MANEA |
| 23 | 22 | 21 | 20 | 19 | 18 | 17 | 16 |
| – | – | – | MANE | CTSIC | DCDIC | DSRIC | RIIC |
| 15 | 14 | 13 | 12 | 11 | 10 | 9 | 8 |
| – | – | NACK | RXBUFFER | – | ITER/UNRE | TXEMPTY | TIMEOUT |
| 7 | 6 | 5 | 4 | 3 | 2 | 1 | 0 |
| PARE | FRAME | OVRE | – | – | RXBRK | TXRDY | RXRDY |

Writing a zero to a bit in this register has no effect.

Writing a one to a bit in this register will set the corresponding bit in IMR.

For backward compatibility the MANE bit has been duplicated to the MANEA bit position. Writing either one or the other has the same effect.

21.7.4 Interrupt Disable Register

Name: IDR
Access Type: Write-only
Offset: 0xC
Reset Value: 0x00000000

| | | | | | | | |
|------|-------|------|----------|-------|-----------|---------|---------|
| 31 | 30 | 29 | 28 | 27 | 26 | 25 | 24 |
| – | – | – | – | – | – | – | MANEA |
| 23 | 22 | 21 | 20 | 19 | 18 | 17 | 16 |
| – | – | – | MANE | CTSIC | DCDIC | DSRIC | RIIC |
| 15 | 14 | 13 | 12 | 11 | 10 | 9 | 8 |
| – | – | NACK | RXBUFFER | – | ITER/UNRE | TXEMPTY | TIMEOUT |
| 7 | 6 | 5 | 4 | 3 | 2 | 1 | 0 |
| PARE | FRAME | OVRE | – | – | RXBRK | TXRDY | RXRDY |

Writing a zero to a bit in this register has no effect.

Writing a one to a bit in this register will clear the corresponding bit in IMR.

For backward compatibility the MANE bit has been duplicated to the MANEA bit position. Writing either one or the other has the same effect.

21.7.5 Interrupt Mask Register

Name: IMR
Access Type: Read-only
Offset: 0x10
Reset Value: 0x00000000

| | | | | | | | |
|------|-------|------|----------|-------|-----------|---------|---------|
| 31 | 30 | 29 | 28 | 27 | 26 | 25 | 24 |
| – | – | – | – | – | – | – | MANEA |
| 23 | 22 | 21 | 20 | 19 | 18 | 17 | 16 |
| – | – | – | MANE | CTSIC | DCDIC | DSRIC | RIIC |
| 15 | 14 | 13 | 12 | 11 | 10 | 9 | 8 |
| – | – | NACK | RXBUFFER | – | ITER/UNRE | TXEMPTY | TIMEOUT |
| 7 | 6 | 5 | 4 | 3 | 2 | 1 | 0 |
| PARE | FRAME | OVRE | – | – | RXBRK | TXRDY | RXRDY |

0: The corresponding interrupt is disabled.

1: The corresponding interrupt is enabled.

A bit in this register is cleared when the corresponding bit in IDR is written to one.

A bit in this register is set when the corresponding bit in IER is written to one.

For backward compatibility the MANE bit has been duplicated to the MANEA bit position. Reading either one or the other has the same effect.

21.7.6 Channel Status Register

Name: CSR
Access Type: Read-only
Offset: 0x14
Reset Value: 0x00000000

| | | | | | | | |
|------|-------|------|----------|-------|-----------|---------|---------|
| 31 | 30 | 29 | 28 | 27 | 26 | 25 | 24 |
| – | – | – | – | – | – | – | MANERR |
| 23 | 22 | 21 | 20 | 19 | 18 | 17 | 16 |
| CTS | DCD | DSR | RI | CTSIC | DCDIC | DSRIC | RIIC |
| 15 | 14 | 13 | 12 | 11 | 10 | 9 | 8 |
| – | – | NACK | RXBUFFER | – | ITER/UNRE | TXEMPTY | TIMEOUT |
| 7 | 6 | 5 | 4 | 3 | 2 | 1 | 0 |
| PARE | FRAME | OVRE | – | – | RXBRK | TXRDY | RXRDY |

- **MANERR: Manchester Error**
 - 0: No Manchester error has been detected since the last RSTSTA.
 - 1: At least one Manchester error has been detected since the last RSTSTA.
- **CTS: Image of CTS Input**
 - 0: CTS is low.
 - 1: CTS is high.
- **DCD: Image of DCD Input**
 - 0: DCD is low.
 - 1: DCD is high.
- **DSR: Image of DSR Input**
 - 0: DSR is low.
 - 1: DSR is high.
- **RI: Image of RI Input**
 - 0: RI is low.
 - 1: RI is high.
- **CTSIC: Clear to Send Input Change Flag**
 - 0: No change has been detected on the CTS pin since the last CSR read.
 - 1: At least one change has been detected on the CTS pin since the last CSR read.
- **DCDIC: Data Carrier Detect Input Change Flag**
 - 0: No change has been detected on the DCD pin since the last CSR read.
 - 1: At least one change has been detected on the DCD pin since the last CSR read.
- **DSRIC: Data Set Ready Input Change Flag**
 - 0: No change has been detected on the DSR pin since the last CSR read.
 - 1: At least one change has been detected on the DSR pin since the last CSR read.

- **RIIC: Ring Indicator Input Change Flag**
 - 0: No change has been detected on the RI pin since the last CSR read.
 - 1: At least one change has been detected on the RI pin since the last CSR read.

- **NACK: Non Acknowledge**
 - 0: No Non Acknowledge has been detected since the last RSTNACK.
 - 1: At least one Non Acknowledge has been detected since the last RSTNACK.
 - This bit is cleared by writing a one to CR.RSTNACK.

- **RXBUFF: Reception Buffer Full**
 - 0: The Buffer Full signal from the Peripheral DMA Controller channel is inactive.
 - 1: The Buffer Full signal from the Peripheral DMA Controller channel is active.

- **ITER/UNRE: Max number of Repetitions Reached or SPI Underrun Error**
 - If USART does not operate in SPI Slave Mode:
 - ITER=0: Maximum number of repetitions has not been reached since the last RSTSTA.
 - ITER=1: Maximum number of repetitions has been reached since the last RSTSTA.
 - If USART operates in SPI Slave Mode:
 - UNRE=0: No SPI underrun error has occurred since the last RSTSTA.
 - UNRE=1: At least one SPI underrun error has occurred since the last RSTSTA.
 - This bit is cleared by writing a one to CR.RSTSTA.

- **TXEMPTY: Transmitter Empty**
 - 0: The transmitter is either disabled or there are characters in THR, or in the transmit shift register.
 - 1: There are no characters in neither THR, nor in the transmit shift register.
 - This bit is cleared by writing a one to CR.STTBRK.

- **TIMEOUT: Receiver Time-out**
 - 0: There has not been a time-out since the last Start Time-out command (CR.STTTO), or RTOR.TO is zero.
 - 1: There has been a time-out since the last Start Time-out command.
 - This bit is cleared by writing a one to CR.STTTO or CR.RETTO.

- **PARE: Parity Error**
 - 0: Either no parity error has been detected, or the parity bit is a zero in multidrop mode, since the last RSTSTA.
 - 1: Either at least one parity error has been detected, or the parity bit is a one in multidrop mode, since the last RSTSTA.
 - This bit is cleared by writing a one to CR.RSTSTA.

- **FRAME: Framing Error**
 - 0: No stop bit has been found as low since the last RSTSTA.
 - 1: At least one stop bit has been found as low since the last RSTSTA.
 - This bit is cleared by writing a one to CR.RSTSTA.

- **OVRE: Overrun Error**
 - 0: No overrun error has occurred since the last RSTSTA.
 - 1: At least one overrun error has occurred since the last RSTSTA.
 - This bit is cleared by writing a one to CR.RSTSTA.

- **RXBRK: Break Received/End of Break**
 - 0: No Break received or End of Break detected since the last RSTSTA.
 - 1: Break received or End of Break detected since the last RSTSTA.
 - This bit is cleared by writing a one to CR.RSTSTA.

- **TXRDY: Transmitter Ready**
 - 0: The transmitter is either disabled, or a character in THR is waiting to be transferred to the transmit shift register, or an STTBRK command has been requested. As soon as the transmitter is enabled, TXRDY is set.
 - 1: There is no character in the THR.
 - This bit is cleared by writing a one to CR.STTBRK.

- **RXRDY: Receiver Ready**
 - 0: The receiver is either disabled, or no complete character has been received since the last read of RHR. If characters were being received when the receiver was disabled, RXRDY changes to 1 when the receiver is enabled.
 - 1: At least one complete character has been received and RHR has not yet been read.

This bit is cleared when the Receive Holding Register (RHR) is read.

21.7.7 Receiver Holding Register

Name: RHR
Access Type: Read-only
Offset: 0x18
Reset Value: 0x00000000

| | | | | | | | |
|------------|----|----|----|----|----|----|----------|
| 31 | 30 | 29 | 28 | 27 | 26 | 25 | 24 |
| – | – | – | – | – | – | – | – |
| 23 | 22 | 21 | 20 | 19 | 18 | 17 | 16 |
| – | – | – | – | – | – | – | – |
| 15 | 14 | 13 | 12 | 11 | 10 | 9 | 8 |
| RXSYNH | – | – | – | – | – | – | RXCHR[8] |
| 7 | 6 | 5 | 4 | 3 | 2 | 1 | 0 |
| RXCHR[7:0] | | | | | | | |

Reading this register will clear the CSR.RXRDY bit.

- **RXSYNH: Received Sync**
 - 0: Last character received is a data sync.
 - 1: Last character received is a command sync.
- **RXCHR: Received Character**
 - Last received character.

21.7.8 Transmitter Holding Register

Name: THR
Access Type: Write-only
Offset: 0x1C
Reset Value: 0x00000000

| | | | | | | | |
|------------|----|----|----|----|----|----|----------|
| 31 | 30 | 29 | 28 | 27 | 26 | 25 | 24 |
| – | – | – | – | – | – | – | – |
| 23 | 22 | 21 | 20 | 19 | 18 | 17 | 16 |
| – | – | – | – | – | – | – | – |
| 15 | 14 | 13 | 12 | 11 | 10 | 9 | 8 |
| TXSYNH | – | – | – | – | – | – | TXCHR[8] |
| 7 | 6 | 5 | 4 | 3 | 2 | 1 | 0 |
| TXCHR[7:0] | | | | | | | |

- TXSYNH: Sync Field to be transmitted**
 0: If MR.VARSYNC is a one, the next character sent is encoded as data, and the start frame delimiter is a data sync.
 1: If MR.VARSYNC is a one, the next character sent is encoded as a command, and the start frame delimiter is a command sync.
- TXCHR: Character to be Transmitted**
 If TXRDY is zero this field contains the next character to be transmitted.

21.7.9 Baud Rate Generator Register

Name: BRGR
Access Type: Read-write
Offset: 0x20
Reset Value: 0x00000000

| | | | | | | | |
|----------|----|----|----|----|----|----|----|
| 31 | 30 | 29 | 28 | 27 | 26 | 25 | 24 |
| – | – | – | – | – | – | – | – |
| 23 | 22 | 21 | 20 | 19 | 18 | 17 | 16 |
| – | – | – | – | – | FP | | |
| 15 | 14 | 13 | 12 | 11 | 10 | 9 | 8 |
| CD[15:8] | | | | | | | |
| 7 | 6 | 5 | 4 | 3 | 2 | 1 | 0 |
| CD[7:0] | | | | | | | |

- **FP: Fractional Part**
 0: Fractional divider is disabled.
 1 - 7: Baud rate resolution, defined by FP x 1/8.
- **CD: Clock Divider**

Table 21-21. Baud Rate in Asynchronous Mode (MR.SYNC is 0)

| CD | OVER = 0 | OVER = 1 |
|------------|--|---|
| 0 | Baud Rate Clock Disabled | |
| 1 to 65535 | Baud Rate = $\frac{\text{Selected Clock}}{16 \cdot \text{CD}}$ | Baud Rate = $\frac{\text{Selected Clock}}{8 \cdot \text{CD}}$ |

Table 21-22. Baud Rate in Synchronous Mode (MR.SYNC is 1) and SPI Mode

| CD | Baud Rate |
|------------|---|
| 0 | Baud Rate Clock Disabled |
| 1 to 65535 | Baud Rate = $\frac{\text{Selected Clock}}{\text{CD}}$ |

Table 21-23. Baud Rate in ISO7816 Mode

| CD | Baud Rate |
|------------|---|
| 0 | Baud Rate Clock Disabled |
| 1 to 65535 | $\text{Baud Rate} = \frac{\text{Selected Clock}}{\text{FI_DI_RATIO} \cdot \text{CD}}$ |

21.7.10 Receiver Time-out Register

Name: RTOR
Access Type: Read-write
Offset: 0x24
Reset Value: 0x00000000

| | | | | | | | |
|----------|----|----|----|----|----|----|----|
| 31 | 30 | 29 | 28 | 27 | 26 | 25 | 24 |
| – | – | – | – | – | – | – | – |
| 23 | 22 | 21 | 20 | 19 | 18 | 17 | 16 |
| – | – | – | – | – | – | – | – |
| 15 | 14 | 13 | 12 | 11 | 10 | 9 | 8 |
| TO[15:8] | | | | | | | |
| 7 | 6 | 5 | 4 | 3 | 2 | 1 | 0 |
| TO[7:0] | | | | | | | |

- TO: Time-out Value**

0: The receiver Time-out is disabled.

1 - 65535: The receiver Time-out is enabled and the time-out delay is TO x bit period.

Note that the size of the TO counter is device dependent, see the Module Configuration section.

21.7.11 Transmitter Timeguard Register

Name: TTGR
Access Type: Read-write
Offset: 0x28
Reset Value: 0x00000000

| | | | | | | | |
|----|----|----|----|----|----|----|----|
| 31 | 30 | 29 | 28 | 27 | 26 | 25 | 24 |
| – | – | – | – | – | – | – | – |
| 23 | 22 | 21 | 20 | 19 | 18 | 17 | 16 |
| – | – | – | – | – | – | – | – |
| 15 | 14 | 13 | 12 | 11 | 10 | 9 | 8 |
| – | – | – | – | – | – | – | – |
| 7 | 6 | 5 | 4 | 3 | 2 | 1 | 0 |
| TG | | | | | | | |

- **TG: Timeguard Value**

0: The transmitter Timeguard is disabled.

1 - 255: The transmitter timeguard is enabled and the timeguard delay is TG x bit period.

21.7.12 FI DI Ratio Register

Name: FIDI
Access Type: Read-write
Offset: 0x40
Reset Value: 0x00000174

| | | | | | | | |
|------------------|----|----|----|----|-------------------|----|----|
| 31 | 30 | 29 | 28 | 27 | 26 | 25 | 24 |
| – | – | – | – | – | – | – | – |
| 23 | 22 | 21 | 20 | 19 | 18 | 17 | 16 |
| – | – | – | – | – | – | – | – |
| 15 | 14 | 13 | 12 | 11 | 10 | 9 | 8 |
| – | – | – | – | – | FI_DI_RATIO[10:8] | | |
| 7 | 6 | 5 | 4 | 3 | 2 | 1 | 0 |
| FI_DI_RATIO[7:0] | | | | | | | |

- **FI_DI_RATIO: FI Over DI Ratio Value**

0: If ISO7816 mode is selected, the baud rate generator does not generate a signal.

1 - 2047: If ISO7816 mode is selected, the baud rate is the clock provided on CLK divided by FI_DI_RATIO.

21.7.13 Number of Errors Register

Name: NER
Access Type: Read-only
Offset: 0x44
Reset Value: 0x00000000

| | | | | | | | |
|-----------|----|----|----|----|----|----|----|
| 31 | 30 | 29 | 28 | 27 | 26 | 25 | 24 |
| – | – | – | – | – | – | – | – |
| 23 | 22 | 21 | 20 | 19 | 18 | 17 | 16 |
| – | – | – | – | – | – | – | – |
| 15 | 14 | 13 | 12 | 11 | 10 | 9 | 8 |
| – | – | – | – | – | – | – | – |
| 7 | 6 | 5 | 4 | 3 | 2 | 1 | 0 |
| NB_ERRORS | | | | | | | |

- NB_ERRORS: Number of Errors**
 Total number of errors that occurred during an ISO7816 transfer. This register automatically clears when read.

21.7.14 IrDA Filter Register

Name: IFR
Access Type: Read-write
Offset: 0x4C
Reset Value: 0x00000000

| | | | | | | | |
|-------------|----|----|----|----|----|----|----|
| 31 | 30 | 29 | 28 | 27 | 26 | 25 | 24 |
| – | – | – | – | – | – | – | – |
| 23 | 22 | 21 | 20 | 19 | 18 | 17 | 16 |
| – | – | – | – | – | – | – | – |
| 15 | 14 | 13 | 12 | 11 | 10 | 9 | 8 |
| – | – | – | – | – | – | – | – |
| 7 | 6 | 5 | 4 | 3 | 2 | 1 | 0 |
| IRDA_FILTER | | | | | | | |

- **IRDA_FILTER: IrDA Filter**
 Configures the IrDA demodulator filter.

21.7.15 Manchester Configuration Register

Name: MAN
Access Type: Read-write
Offset: 0x50
Reset Value: 0x30011004

| | | | | | | | |
|----|-------|----|---------|-------|----|-------|----|
| 31 | 30 | 29 | 28 | 27 | 26 | 25 | 24 |
| – | DRIFT | 1 | RX_MPOL | – | – | RX_PP | |
| 23 | 22 | 21 | 20 | 19 | 18 | 17 | 16 |
| – | – | – | – | RX_PL | | | |
| 15 | 14 | 13 | 12 | 11 | 10 | 9 | 8 |
| – | – | – | TX_MPOL | – | – | TX_PP | |
| 7 | 6 | 5 | 4 | 3 | 2 | 1 | 0 |
| – | – | – | – | TX_PL | | | |

- **DRIFT: Drift compensation**
 0: The USART can not recover from a clock drift.
 1: The USART can recover from clock drift (only available in 16x oversampling mode).
- **RX_MPOL: Receiver Manchester Polarity**
 0: Zeroes are encoded as zero-to-one transitions, and ones are encoded as a one-to-zero transitions.
 1: Zeroes are encoded as one-to-zero transitions, and ones are encoded as a zero-to-one transitions.
- **RX_PP: Receiver Preamble Pattern detected**

Table 21-24.

| RX_PP | | Preamble Pattern default polarity assumed (RX_MPOL field not set) |
|-------|---|---|
| 0 | 0 | ALL_ONE |
| 0 | 1 | ALL_ZERO |
| 1 | 0 | ZERO_ONE |
| 1 | 1 | ONE_ZERO |

- **RX_PL: Receiver Preamble Length**
 0: The receiver preamble pattern detection is disabled.
 1 - 15: The detected preamble length is RX_PL x bit period
- **TX_MPOL: Transmitter Manchester Polarity**
 0: Zeroes are encoded as zero-to-one transitions, and ones are encoded as a one-to-zero transitions.
 1: Zeroes are encoded as one-to-zero transitions, and ones are encoded as a zero-to-one transitions.

- **TX_PP: Transmitter Preamble Pattern**

Table 21-25.

| TX_PP | | Preamble Pattern default polarity assumed (TX_MPOL field not set) |
|-------|---|---|
| 0 | 0 | ALL_ONE |
| 0 | 1 | ALL_ZERO |
| 1 | 0 | ZERO_ONE |
| 1 | 1 | ONE_ZERO |

- **TX_PL: Transmitter Preamble Length**
 - 0: The transmitter preamble pattern generation is disabled
 - 1 - 15: The preamble length is TX_PL x bit period

21.7.16 Version Register

Name: VERSION

Access Type: Read-only

Offset: 0xFC

Reset Value: -

| | | | | | | | |
|--------------|----|----|----|---------------|----|----|----|
| 31 | 30 | 29 | 28 | 27 | 26 | 25 | 24 |
| - | - | - | - | - | - | - | - |
| 23 | 22 | 21 | 20 | 19 | 18 | 17 | 16 |
| - | - | - | - | MFN | | | |
| 15 | 14 | 13 | 12 | 11 | 10 | 9 | 8 |
| - | - | - | - | VERSION[11:8] | | | |
| 7 | 6 | 5 | 4 | 3 | 2 | 1 | 0 |
| VERSION[7:0] | | | | | | | |

- **MFN**
Reserved. No functionality associated.
- **VERSION**
Version of the module. No functionality associated.

21.8 Module Configuration

The specific configuration for each USART instance is listed in the following tables. The module bus clocks listed here are connected to the system bus clocks according to the table in the System Bus Clock Connections section.

Table 21-26. Module Configuration

| Feature | USART0 | USART1 | USART2 |
|--------------------------------|-----------------|-------------|-----------------|
| SPI Logic | Implemented | Implemented | Implemented |
| RS485 Logic | Not Implemented | Implemented | Not Implemented |
| Manchester Logic | Not Implemented | Implemented | Not Implemented |
| Modem Logic | Not Implemented | Implemented | Not Implemented |
| IRDA Logic | Not Implemented | Implemented | Not Implemented |
| Fractional Baudrate | Implemented | Implemented | Implemented |
| ISO7816 | Not Implemented | Implemented | Not Implemented |
| DIV | 8 | 8 | 8 |
| Receiver Time-out Counter Size | 8-bits | 17-bits | 8-bits |

Table 21-27. Module Clock Name

| Module name | Clock name |
|-------------|------------|
| USART0 | CLK_USART0 |
| USART1 | CLK_USART1 |
| USART2 | CLK_USART2 |

22. USB Interface (USBB)

Rev: 3.1.0.1.18

22.1 Features

- Compatible with the USB 2.0 specification
- Supports Full (12Mbit/s) and Low (1.5 Mbit/s) speed Device and Embedded Host
- seven pipes/endpoints
- 960 of Embedded Dual-Port RAM (DPRAM) for Pipes/Endpoints
- Up to 2 memory banks per Pipe/Endpoint (Not for Control Pipe/Endpoint)
- Flexible Pipe/Endpoint configuration and management with dedicated DMA channels
- On-Chip transceivers including Pull-Ups/Pull-downs
- On-Chip pad including VBUS analog comparator

22.2 Overview

The Universal Serial Bus (USB) MCU device complies with the Universal Serial Bus (USB) 2.0 specification, but it does NOT feature Hi-Speed USB (480 Mbit/s).

Each pipe/endpoint can be configured in one of several transfer types. It can be associated with one or more banks of a dual-port RAM (DPRAM) used to store the current data payload. If several banks are used (“ping-pong” mode), then one DPRAM bank is read or written by the CPU or the DMA while the other is read or written by the USBB core. This feature is mandatory for isochronous pipes/endpoints.

[Table 22-1 on page 352](#) describes the hardware configuration of the USB MCU device.

Table 22-1. Description of USB Pipes/Endpoints

| Pipe/Endpoint | Mnemonic | Max. Size | Max. Nb. Banks | DMA | Type |
|---------------|----------|-----------|----------------|-----|------------------------------------|
| 0 | PEP0 | 64 bytes | 1 | N | Control |
| 1 | PEP1 | 64 bytes | 2 | Y | Isochronous/Bulk/Interrupt/Control |
| 2 | PEP2 | 64 bytes | 2 | Y | Isochronous/Bulk/Interrupt/Control |
| 3 | PEP3 | 64 bytes | 2 | Y | Isochronous/Bulk/Interrupt/Control |
| 4 | PEP4 | 64 bytes | 2 | Y | Isochronous/Bulk/Interrupt/Control |
| 5 | PEP5 | 256 bytes | 2 | Y | Isochronous/Bulk/Interrupt/Control |
| 6 | PEP6 | 256 bytes | 2 | Y | Isochronous/Bulk/Interrupt/Control |

The theoretical maximal pipe/endpoint configuration (1600) exceeds the real DPRAM size (960). The user needs to be aware of this when configuring pipes/endpoints. To fully use the 960 of DPRAM, the user could for example use the configuration described in [Table 22-2 on page 352](#).

Table 22-2. Example of Configuration of Pipes/Endpoints Using the Whole DPRAM

| Pipe/Endpoint | Mnemonic | Size | Nb. Banks |
|---------------|----------|----------|-----------|
| 0 | PEP0 | 64 bytes | 1 |
| 1 | PEP1 | 64 bytes | 1 |
| 2 | PEP2 | 64 bytes | 1 |
| 3 | PEP3 | 64 bytes | 2 |

Table 22-2. Example of Configuration of Pipes/Endpoints Using the Whole DPRAM

| Pipe/Endpoint | Mnemonic | Size | Nb. Banks |
|---------------|----------|-----------|-----------|
| 4 | PEP4 | 64 bytes | 2 |
| 5 | PEP5 | 256 bytes | 1 |
| 6 | PEP6 | 256 bytes | 1 |

22.3 Block Diagram

The USBB provides a hardware device to interface a USB link to a data flow stored in a dual-port RAM (DPRAM).

The USBB requires a 48MHz \pm 0.25% reference clock, which is the USB generic clock generated from one of the power manager oscillators, optionally through one of the power manager PLLs.

The 48MHz clock is used to generate a 12MHz full-speed (or 1.5 MHz low-speed) bit clock from the received USB differential data and to transmit data according to full- or low-speed USB device tolerance. Clock recovery is achieved by a digital phase-locked loop (a DPPLL, not represented), which complies with the USB jitter specifications.

Figure 22-1. USB Block Diagram

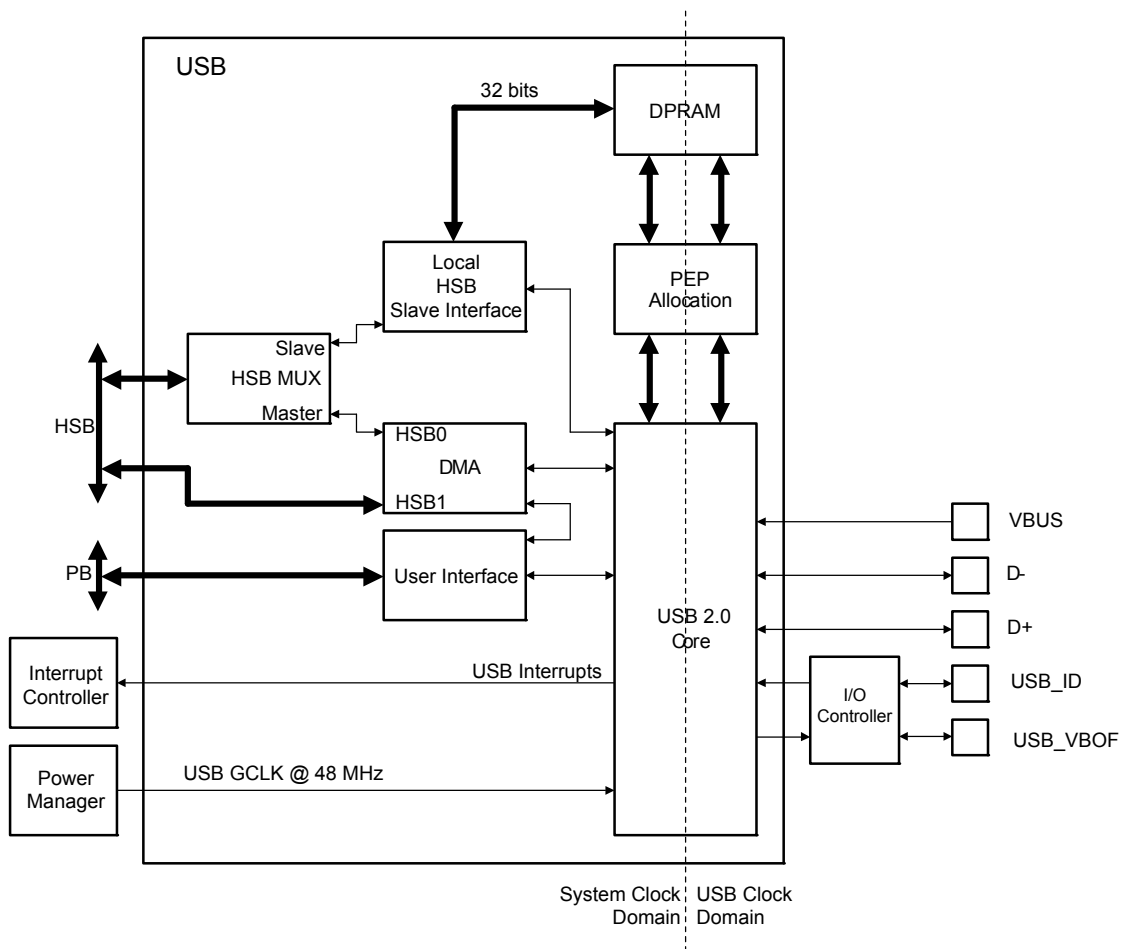

22.4 Application Block Diagram

Depending on the USB operating mode (device-only, reduced-host modes) and the power source (bus-powered or self-powered), there are different typical hardware implementations.

22.4.1 Device Mode

22.4.1.1 Bus-Powered device

Figure 22-2. Bus-Powered Device Application Block Diagram

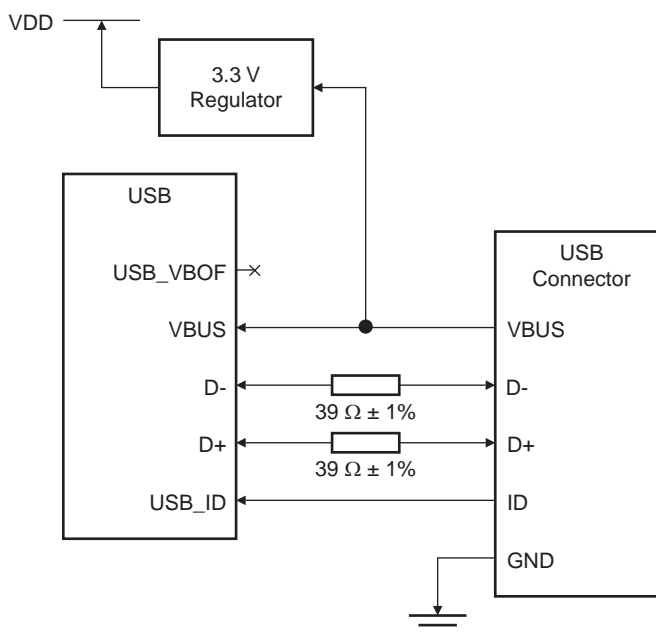

22.4.1.2 Self-Powered device

Figure 22-3. Self-Powered Device Application Block Diagram

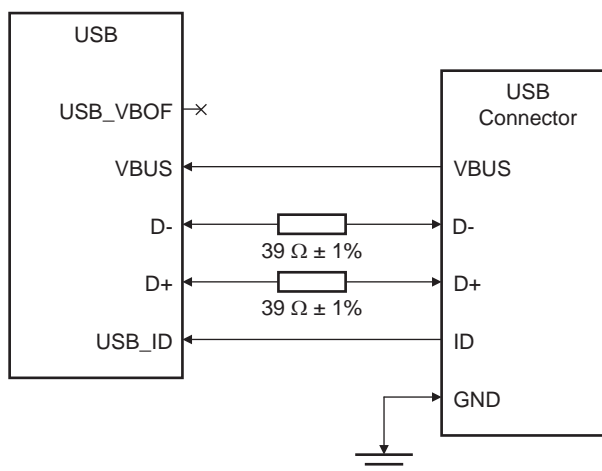

22.4.2 Host Mode

Figure 22-4. Host Application Block Diagram

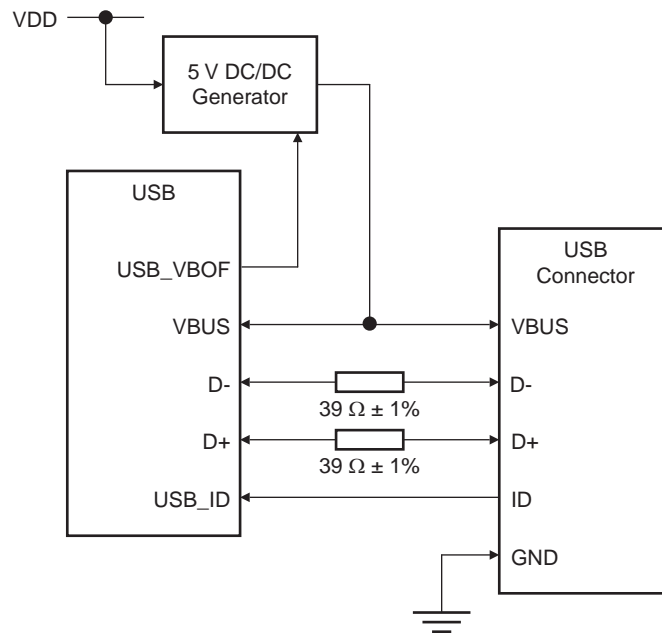

22.5 I/O Lines Description

Table 22-3. I/O Lines Description

| Pin Name | Pin Description | Type | Active Level |
|----------|--|--------------|---|
| USB_VBOF | USB VBus On/Off: Bus Power Control Port | Output | $\overline{\text{VBUSPO}}$ |
| USB_VBUS | VBus: Bus Power Measurement Port | Input | |
| D- | Data -: Differential Data Line - Port | Input/Output | |
| D+ | Data +: Differential Data Line + Port | Input/Output | |
| USB_ID | USB Identification: Mini Connector Identification Port | Input | Low: Mini-A plug High Z: Mini-B plug |

22.6 Product Dependencies

In order to use this module, other parts of the system must be configured correctly, as described below.

22.6.1 I/O Lines

The USB_VBOF and USB_ID pins are multiplexed with I/O Controller lines and may also be multiplexed with lines of other peripherals. In order to use them with the USB, the user must first configure the I/O Controller to assign them to their USB peripheral functions.

If USB_ID is used, the I/O Controller must be configured to enable the internal pull-up resistor of its pin.

If USB_VBOF or USB_ID is not used by the application, the corresponding pin can be used for other purposes by the I/O Controller or by other peripherals.

22.6.2 Clocks

The clock for the USBB bus interface (CLK_USBB) is generated by the Power Manager. This clock is enabled at reset, and can be disabled in the Power Manager. It is recommended to disable the USBB before disabling the clock, to avoid freezing the USBB in an undefined state.

The 48MHz USB clock is generated by a dedicated generic clock from the Power Manager. Before using the USB, the user must ensure that the USB generic clock (GCLK_USBB) is enabled at 48MHz in the Power Manager.

22.6.3 Interrupts

The USBB interrupt request line is connected to the interrupt controller. Using the USBB interrupt requires the interrupt controller to be programmed first.

22.7 Functional Description

22.7.1 USB General Operation

22.7.1.1 Introduction

After a hardware reset, the USBB is disabled. When enabled, the USBB runs either in device mode or in host mode according to the ID detection.

If the USB_ID pin is not connected to ground, the USB_ID Pin State bit in the General Status register (USBSTA.ID) is set (the internal pull-up resistor of the USB_ID pin must be enabled by the I/O Controller) and device mode is engaged.

The USBSTA.ID bit is cleared when a low level has been detected on the USB_ID pin. Host mode is then engaged.

22.7.1.2 Power-On and reset

Figure 22-5 on page 359 describes the USBB main states.

Figure 22-5. General States

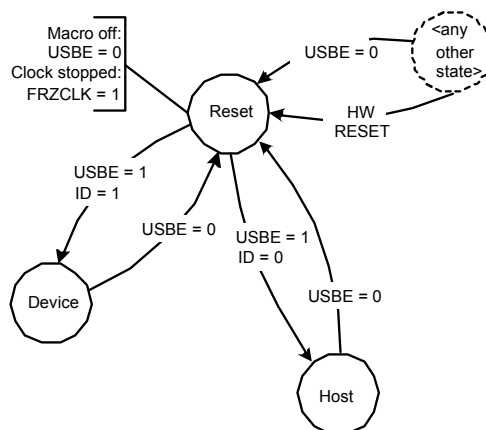

After a hardware reset, the USBB is in the Reset state. In this state:

- The macro is disabled. The USBB Enable bit in the General Control register (USBCON.USBE) is zero.
- The macro clock is stopped in order to minimize power consumption. The Freeze USB Clock bit in USBCON (USBCON.FRZCLK) is set.
- The pad is in suspend mode.
- The internal states and registers of the device and host modes are reset.
- The DPRAM is not cleared and is accessible.
- The USBSTA.ID bit and the VBus Level bit in the USBSTA (USBSTA.VBUS) reflect the states of the USB_ID and USB_VBUS input pins.
- The OTG Pad Enable (OTGPADE) bit, the VBus Polarity (VBUSPO) bit, the FRZCLK bit, the USBE bit, the USB_ID Pin Enable (UIDE) bit, the USBB Mode (UIMOD) bit in USBCON, and the Low-Speed Mode Force bit in the Device General Control (UDCON.LS) register can be written by software, so that the user can program pads and speed before enabling the macro, but their value is only taken into account once the macro is enabled and unfrozen.

After writing a one to USBCON.USBE, the USBB enters the Device or the Host mode (according to the ID detection) in idle state.

The USBB can be disabled at any time by writing a zero to USBCON.USBE. In fact, writing a zero to USBCON.USBE acts as a hardware reset, except that the OTGPADE, VBUSPO, FRZCLK, UIDE, UIMOD and, LS bits are not reset.

22.7.1.3 *Interrupts*

One interrupt vector is assigned to the USB interface. [Figure 22-6 on page 361](#) shows the structure of the USB interrupt system.

Figure 22-6. Interrupt System

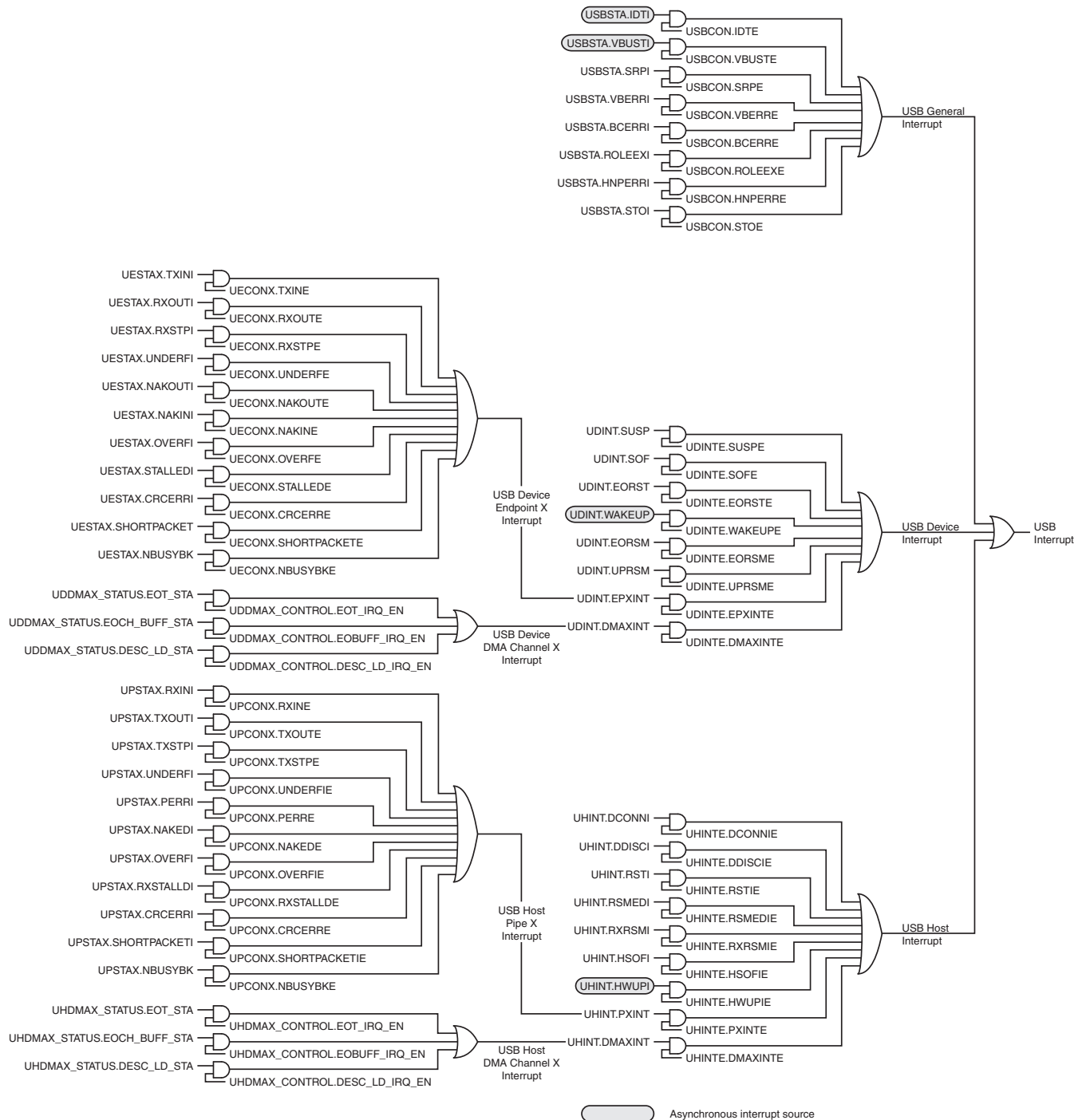

See [Section 22.7.2.17](#) and [Section 22.7.3.13](#) for further details about device and host interrupts.

There are two kinds of general interrupts: processing, i.e. their generation is part of the normal processing, and exception, i.e. errors (not related to CPU exceptions).

The processing general interrupts are:

- The ID Transition Interrupt (IDTI)
- The VBus Transition Interrupt (VBUSTI)
- The Role Exchange Interrupt (ROLEEXI)

The exception general interrupts are:

- The VBus Error Interrupt (VBERRI)
- The B-Connection Error Interrupt (BCERRI)
- The Suspend Time-Out Interrupt (STOI)

22.7.1.4 MCU Power modes

•Run mode

In this mode, all MCU clocks can run, including the USB clock.

•Idle mode

In this mode, the CPU is halted, i.e. the CPU clock is stopped. The Idle mode is entered whatever the state of the USB. The MCU wakes up on any USB interrupt.

•Frozen mode

Same as the Idle mode, except that the HSB module is stopped, so the USB DMA, which is an HSB master, can not be used. Moreover, the USB DMA must be stopped before entering this sleep mode in order to avoid erratic behavior. The MCU wakes up on any USB interrupt.

•Standby, Stop, DeepStop and Static modes

Same as the Frozen mode, except that the USB generic clock and other clocks are stopped, so the USB macro is frozen. Only the asynchronous USB interrupt sources can wake up the MCU in these modes ⁽¹⁾. The Power Manager (PM) may have to be configured to enable asynchronous wake up from USB. The USB module must be frozen by writing a one to the FRZCLK bit.

Note: 1. When entering a sleep mode deeper or equal to DeepStop, the VBus asynchronous interrupt can not be triggered because the bandgap voltage reference is off. Thus this interrupt should be disabled (USBCON.VBUSTE = 0).

•USB clock frozen

In the run, idle and frozen MCU modes, the USB can be frozen when the USB line is in the suspend mode, by writing a one to the FRZCLK bit, what reduces power consumption.

In deeper MCU power modes (from StandBy mode), the USB must be frozen.

In this case, it is still possible to access the following elements, but only in Run mode:

- The OTGPADE, VBUSPO, FRZCLK, USBE, UIDE, UIMOD and LS bits in the USBCON register
- The DPRAM (through the USB Pipe/Endpoint n FIFO Data (USBFIFO n DATA) registers, but not through USB bus transfers which are frozen)

Moreover, when FRZCLK is written to one, only the asynchronous interrupt sources may trigger the USB interrupt:

- The ID Transition Interrupt (IDTI)
- The VBus Transition Interrupt (VBUSTI)
- The Wake-up Interrupt (WAKEUP)
- The Host Wake-up Interrupt (HWUPI)

•*USB Suspend mode*

In peripheral mode, the Suspend Interrupt bit in the Device Global Interrupt register (UDINT.SUSP) indicates that the USB line is in the suspend mode. In this case, the USB Data UTMI transceiver is automatically set in suspend mode to reduce the consumption.

22.7.1.5 *Speed control*

•*Device mode*

When the USB interface is in device mode, the speed selection (full-/low-speed) depends on which of D+ and D- is pulled up. The LS bit allows to connect an internal pull-up resistor either on D+ (full-speed mode) or on D- (low-speed mode). The LS bit shall be written before attaching the device, what can be done by clearing the DETACH bit in UDCON.

Figure 22-7. Speed Selection in Device Mode

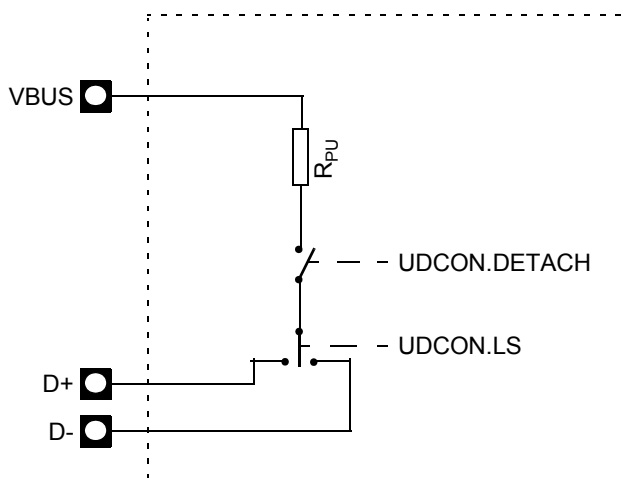

•*Host mode*

When the USB interface is in host mode, internal pull-down resistors are connected on both D+ and D- and the interface detects the speed of the connected device, which is reflected by the Speed Status (SPEED) field in USBSTA.

22.7.1.6 *DPRAM management*

Pipes and endpoints can only be allocated in ascending order (from the pipe/endpoint 0 to the last pipe/endpoint to be allocated). The user shall therefore configure them in the same order.

The allocation of a pipe/endpoint n starts when the Endpoint Memory Allocate bit in the Endpoint n Configuration register (UECFGn.ALLOC) is written to one. Then, the hardware allocates a

memory area in the DPRAM and inserts it between the n-1 and n+1 pipes/endpoints. The n+1 pipe/endpoint memory window slides up and its data is lost. Note that the following pipe/endpoint memory windows (from n+2) do not slide.

Disabling a pipe, by writing a zero to the Pipe n Enable bit in the Pipe Enable/Reset register (UPRST.PENn), or disabling an endpoint, by writing a zero to the Endpoint n Enable bit in the Endpoint Enable/Reset register (UERST.EPENn), resets neither the UECFGn.ALLOC bit nor its configuration (the Pipe Banks (PBK) field, the Pipe Size (PSIZE) field, the Pipe Token (PTOKEN) field, the Pipe Type (PTYPE) field, the Pipe Endpoint Number (PEPNUM) field, and the Pipe Interrupt Request Frequency (INTFRQ) field in the Pipe n Configuration (UPCFGn) register/the Endpoint Banks (EPBK) field, the Endpoint Size (EPSIZE) field, the Endpoint Direction (EPDIR) field, and the Endpoint Type (EPTYPE) field in UECFGn).

To free its memory, the user shall write a zero to the UECFGn.ALLOC bit. The n+1 pipe/endpoint memory window then slides down and its data is lost. Note that the following pipe/endpoint memory windows (from n+2) does not slide.

Figure 22-8 on page 364 illustrates the allocation and reorganization of the DPRAM in a typical example.

Figure 22-8. Allocation and Reorganization of the DPRAM

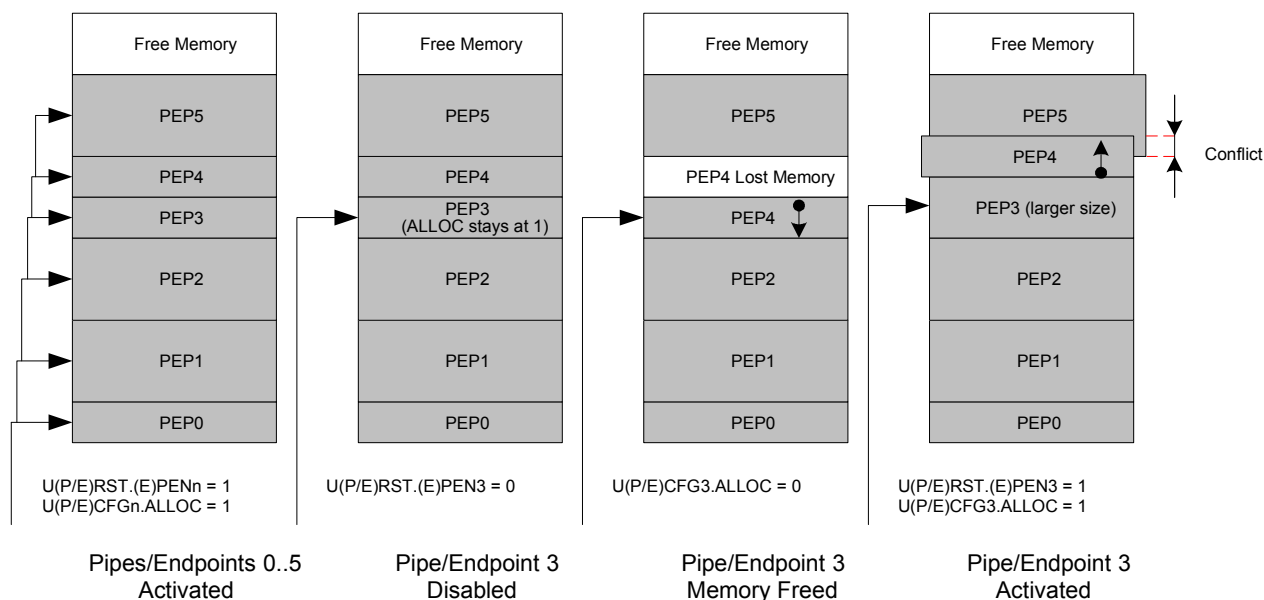

1. The pipes/endpoints 0 to 5 are enabled, configured and allocated in ascending order. Each pipe/endpoint then owns a memory area in the DPRAM.
2. The pipe/endpoint 3 is disabled, but its memory is kept allocated by the controller.
3. In order to free its memory, its ALLOC bit is written to zero. The pipe/endpoint 4 memory window slides down, but the pipe/endpoint 5 does not move.
4. If the user chooses to reconfigure the pipe/endpoint 3 with a larger size, the controller allocates a memory area after the pipe/endpoint 2 memory area and automatically slides up the pipe/endpoint 4 memory window. The pipe/endpoint 5 does not move and a memory conflict appears as the memory windows of the pipes/endpoints 4 and 5 overlap. The data of these pipes/endpoints is potentially lost.

Note that:

- There is no way the data of the pipe/endpoint 0 can be lost (except if it is de-allocated) as memory allocation and de-allocation may affect only higher pipes/endpoints.
- Deactivating then reactivating a same pipe/endpoint with the same configuration only modifies temporarily the controller DPRAM pointer and size for this pipe/endpoint, but nothing changes in the DPRAM, so higher endpoints seem to not have been moved and their data is preserved as far as nothing has been written or received into them while changing the allocation state of the first pipe/endpoint.
- When the user write a one to the ALLOC bit, the Configuration OK Status bit in the Endpoint n Status register (UESTAn.CFGOK) is set only if the configured size and number of banks are correct compared to their maximal allowed values for the endpoint and to the maximal FIFO size (i.e. the DPRAM size), so the value of CFGOK does not consider memory allocation conflicts.

22.7.1.7 Pad Suspend

Figure 22-9 on page 365 shows the pad behavior.

Figure 22-9. Pad Behavior

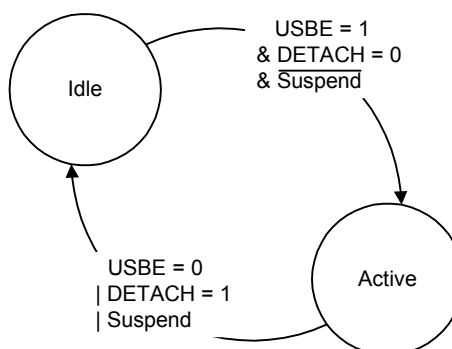

- In the Idle state, the pad is put in low power consumption mode, i.e., the differential receiver of the USB pad is off, and internal pull-down with strong value(15K) are set in both DP/DM to avoid floating lines.
- In the Active state, the pad is working.

Figure 22-10 on page 366 illustrates the pad events leading to a PAD state change.

Figure 22-10. Pad Events

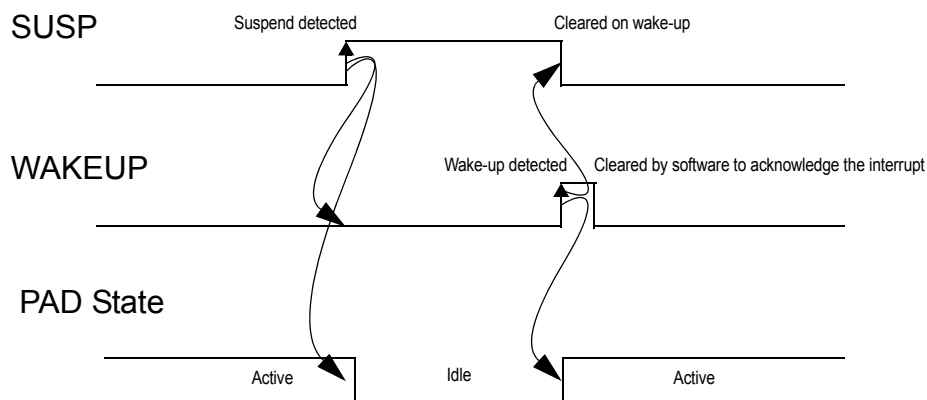

The SUSP bit is set and the Wake-Up Interrupt (WAKEUP) bit in UDINT is cleared when a USB “Suspend” state has been detected on the USB bus. This event automatically puts the USB pad in the Idle state. The detection of a non-idle event sets WAKEUP, clears SUSP and wakes up the USB pad.

Moreover, the pad goes to the Idle state if the macro is disabled or if the DETACH bit is written to one. It returns to the Active state when USBE is written to one and DETACH is written to zero.

22.7.1.8 Plug-In detection

The USB connection is detected from the USB_VBUS pad. [Figure 22-11 on page 366](#) shows the architecture of the plug-in detector.

Figure 22-11. Plug-In Detection Input Block Diagram

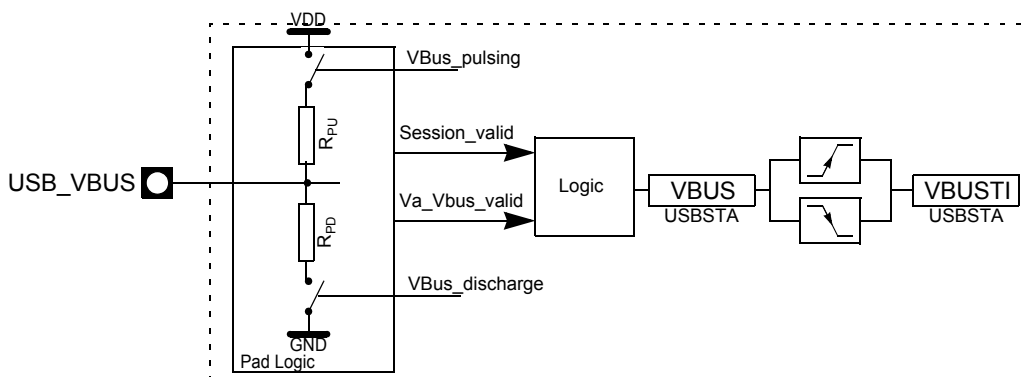

The control logic of the USB_VBUS pad outputs two signals:

- The Session_valid signal is high when the voltage on the USB_VBUS pad is higher than or equal to 1.4V.
- The Va_Vbus_valid signal is high when the voltage on the USB_VBUS pad is higher than or equal to 4.4V.

In device mode, the USBSTA.VBUS bit follows the Session_valid comparator output:

- It is set when the voltage on the USB_VBUS pad is higher than or equal to 1.4V.

- It is cleared when the voltage on the VBUS pad is lower than 1.4V.

In host mode, the USBSTA.VBUS bit follows an hysteresis based on Session_valid and Va_Vbus_valid:

- It is set when the voltage on the USB_VBUS pad is higher than or equal to 4.4V.
- It is cleared when the voltage on the USB_VBUS pad is lower than 1.4V.

The VBus Transition interrupt (VBUSTI) bit in USBSTA is set on each transition of the USBSTA.VBUS bit.

The USBSTA.VBUS bit is effective whether the USBB is enabled or not.

22.7.1.9 ID detection

Figure 22-12 on page 367 shows how the ID transitions are detected.

Figure 22-12. ID Detection Input Block Diagram

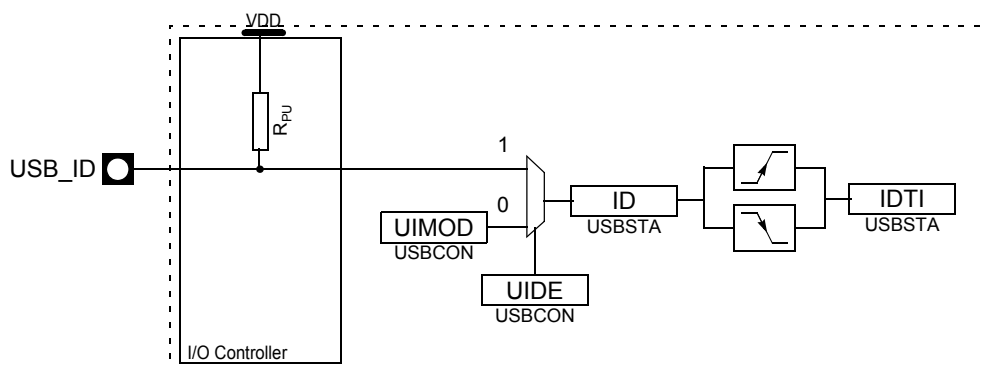

The USB mode (device or host) can be either detected from the USB_ID pin or software selected by writing to the UIMOD bit, according to the UIDE bit. This allows the USB_ID pin to be used as a general purpose I/O pin even when the USB interface is enabled.

By default, the USB_ID pin is selected (UIDE is written to one) and the USBB is in device mode (USBSTA.ID is one), what corresponds to the case where no Mini-A plug is connected, i.e. no plug or a Mini-B plug is connected and the USB_ID pin is kept high by the internal pull-up resistor from the I/O Controller (which must be enabled if USB_ID is used).

The ID Transition Interrupt (IDTI) bit in USBSTA is set on each transition of the ID bit, i.e. when a Mini-A plug (host mode) is connected or disconnected. This does not occur when a Mini-B plug (device mode) is connected or disconnected.

The USBSTA.ID bit is effective whether the USBB is enabled or not.

22.7.2 USB Device Operation

22.7.2.1 Introduction

In device mode, the USBB supports full- and low-speed data transfers.

In addition to the default control endpoint, six endpoints are provided, which can be configured with the types isochronous, bulk or interrupt, as described in [Table 22-1 on page 352](#).

The device mode starts in the Idle state, so the pad consumption is reduced to the minimum.

22.7.2.2 Power-On and reset

[Figure 22-13 on page 368](#) describes the USBB device mode main states.

Figure 22-13. Device Mode States

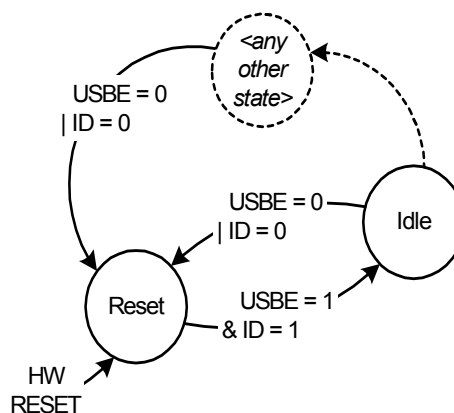

After a hardware reset, the USBB device mode is in the Reset state. In this state:

- The macro clock is stopped in order to minimize power consumption (FRZCLK is written to one).
- The internal registers of the device mode are reset.
- The endpoint banks are de-allocated.
- Neither D+ nor D- is pulled up (DETACH is written to one).

D+ or D- will be pulled up according to the selected speed as soon as the DETACH bit is written to zero and VBus is present. See [“Device mode”](#) for further details.

When the USBB is enabled (USBE is written to one) in device mode (ID is one), its device mode state goes to the Idle state with minimal power consumption. This does not require the USB clock to be activated.

The USBB device mode can be disabled and reset at any time by disabling the USBB (by writing a zero to USBE) or when host mode is engaged (ID is zero).

22.7.2.3 USB reset

The USB bus reset is managed by hardware. It is initiated by a connected host.

When a USB reset is detected on the USB line, the following operations are performed by the controller:

- All the endpoints are disabled, except the default control endpoint.

- The default control endpoint is reset (see [Section 22.7.2.4](#) for more details).
- The data toggle sequence of the default control endpoint is cleared.
- At the end of the reset process, the End of Reset (EORST) bit in UDINT interrupt is set.

22.7.2.4 Endpoint reset

An endpoint can be reset at any time by writing a one to the Endpoint n Reset (EPRSTn) bit in the UERST register. This is recommended before using an endpoint upon hardware reset or when a USB bus reset has been received. This resets:

- The internal state machine of this endpoint.
- The receive and transmit bank FIFO counters.
- All the registers of this endpoint (UECFGn, UESTAn, the Endpoint n Control (UECONn) register), except its configuration (ALLOC, EPBK, EPSIZE, EPDIR, EPTYPE) and the Data Toggle Sequence (DTSEQ) field of the UESTAn register.

Note that the interrupt sources located in the UESTAn register are not cleared when a USB bus reset has been received.

The endpoint configuration remains active and the endpoint is still enabled.

The endpoint reset may be associated with a clear of the data toggle sequence as an answer to the CLEAR_FEATURE USB request. This can be achieved by writing a one to the Reset Data Toggle Set bit in the Endpoint n Control Set register (UECONnSET.RSTDTS). (This will set the Reset Data Toggle (RSTD) bit in UECONn).

In the end, the user has to write a zero to the EPRSTn bit to complete the reset operation and to start using the FIFO.

22.7.2.5 Endpoint activation

The endpoint is maintained inactive and reset (see [Section 22.7.2.4](#) for more details) as long as it is disabled (EPENn is written to zero). DTSEQ is also reset.

The algorithm represented on [Figure 22-14 on page 370](#) must be followed in order to activate an endpoint.

Figure 22-14. Endpoint Activation Algorithm

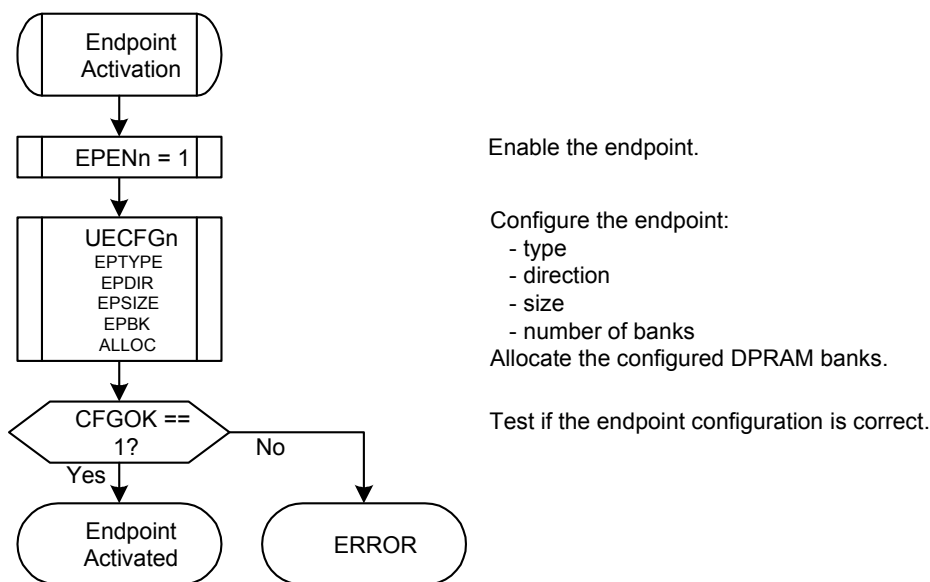

As long as the endpoint is not correctly configured (CFGOK is zero), the controller does not acknowledge the packets sent by the host to this endpoint.

The CFGOK bit is set only if the configured size and number of banks are correct compared to their maximal allowed values for the endpoint (see [Table 22-1 on page 352](#)) and to the maximal FIFO size (i.e. the DPRAM size).

See [Section 22.7.1.6](#) for more details about DPRAM management.

22.7.2.6 *Address setup*

The USB device address is set up according to the USB protocol.

- After all kinds of resets, the USB device address is 0.
- The host starts a SETUP transaction with a SET_ADDRESS(addr) request.
- The user write this address to the USB Address (UADD) field in UDCON, and write a zero to the Address Enable (ADDEN) bit in UDCON, so the actual address is still 0.
- The user sends a zero-length IN packet from the control endpoint.
- The user enables the recorded USB device address by writing a one to ADDEN.

Once the USB device address is configured, the controller filters the packets to only accept those targeting the address stored in UADD.

UADD and ADDEN shall not be written all at once.

UADD and ADDEN are cleared:

- On a hardware reset.
- When the USBB is disabled (USBE written to zero).
- When a USB reset is detected.

When UADD or ADDEN is cleared, the default device address 0 is used.

22.7.2.7 *Suspend and wake-up*

When an idle USB bus state has been detected for 3 ms, the controller set the Suspend (SUSP) interrupt bit in UDINT. The user may then write a one to the FRZCLK bit to reduce power consumption. The MCU can also enter the Idle or Frozen sleep mode to lower again power consumption.

To recover from the Suspend mode, the user shall wait for the Wake-Up (WAKEUP) interrupt bit, which is set when a non-idle event is detected, then write a zero to FRZCLK.

As the WAKEUP interrupt bit in UDINT is set when a non-idle event is detected, it can occur whether the controller is in the Suspend mode or not. The SUSP and WAKEUP interrupts are thus independent of each other except that one bit is cleared when the other is set.

22.7.2.8 *Detach*

The reset value of the DETACH bit is one.

It is possible to initiate a device re-enumeration simply by writing a one then a zero to DETACH.

DETACH acts on the pull-up connections of the D+ and D- pads. See “[Device mode](#)” for further details.

22.7.2.9 *Remote wake-up*

The Remote Wake-Up request (also known as Upstream Resume) is the only one the device may send on its own initiative, but the device should have beforehand been allowed to by a DEVICE_REMOTE_WAKEUP request from the host.

- First, the USBB must have detected a “Suspend” state on the bus, i.e. the Remote Wake-Up request can only be sent after a SUSP interrupt has been set.
- The user may then write a one to the Remote Wake-Up (RMWKUP) bit in UDCON to send an upstream resume to the host for a remote wake-up. This will automatically be done by the controller after 5ms of inactivity on the USB bus.
- When the controller sends the upstream resume, the Upstream Resume (UPRSM) interrupt is set and SUSP is cleared.
- RMWKUP is cleared at the end of the upstream resume.
- If the controller detects a valid “End of Resume” signal from the host, the End of Resume (EORSM) interrupt is set.

22.7.2.10 *STALL request*

For each endpoint, the STALL management is performed using:

- The STALL Request (STALLRQ) bit in UECONn to initiate a STALL request.
- The STALLED Interrupt (STALLEDI) bit in UESTAn is set when a STALL handshake has been sent.

To answer the next request with a STALL handshake, STALLRQ has to be set by writing a one to the STALL Request Set (STALLRQS) bit. All following requests will be discarded (RXOUTI, etc. will not be set) and handshaked with a STALL until the STALLRQ bit is cleared, what is done when a new SETUP packet is received (for control endpoints) or when the STALL Request Clear (STALLRQC) bit is written to one.

Each time a STALL handshake is sent, the STALLEDI bit is set by the USBB and the EPnINT interrupt is set.

- *Special considerations for control endpoints*

If a SETUP packet is received into a control endpoint for which a STALL is requested, the Received SETUP Interrupt (RXSTPI) bit in UESTAn is set and STALLRQ and STALLEDI are cleared. The SETUP has to be ACKed.

This management simplifies the enumeration process management. If a command is not supported or contains an error, the user requests a STALL and can return to the main task, waiting for the next SETUP request.

- *STALL handshake and retry mechanism*

The retry mechanism has priority over the STALL handshake. A STALL handshake is sent if the STALLRQ bit is set and if there is no retry required.

22.7.2.11 Management of control endpoints

- *Overview*

A SETUP request is always ACKed. When a new SETUP packet is received, the RXSTPI is set, but not the Received OUT Data Interrupt (RXOUTI) bit.

The FIFO Control (FIFOCON) bit in UECONn and the Read/Write Allowed (RWALL) bit in UESTAn are irrelevant for control endpoints. The user shall therefore never use them on these endpoints. When read, their value are always zero.

Control endpoints are managed using:

- The RXSTPI bit which is set when a new SETUP packet is received and which shall be cleared by firmware to acknowledge the packet and to free the bank.
- The RXOUTI bit which is set when a new OUT packet is received and which shall be cleared by firmware to acknowledge the packet and to free the bank.
- The Transmitted IN Data Interrupt (TXINI) bit which is set when the current bank is ready to accept a new IN packet and which shall be cleared by firmware to send the packet.

- *Control write*

[Figure 22-15 on page 373](#) shows a control write transaction. During the status stage, the controller will not necessarily send a NAK on the first IN token:

- If the user knows the exact number of descriptor bytes that must be read, it can then anticipate the status stage and send a zero-length packet after the next IN token.
- Or it can read the bytes and wait for the NAKed IN Interrupt (NAKINI) which tells that all the bytes have been sent by the host and that the transaction is now in the status stage.

Figure 22-15. Control Write

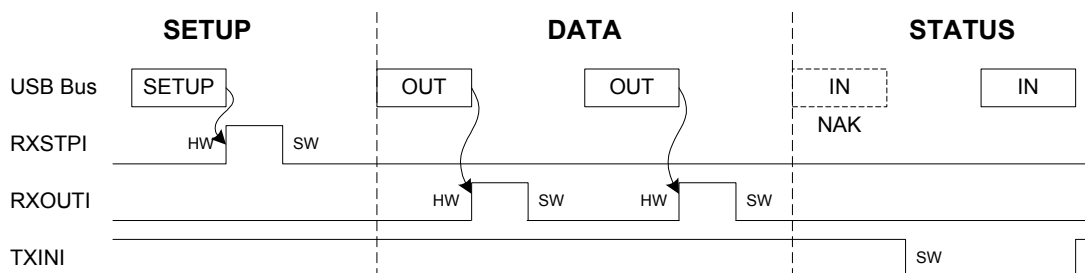

•Control read

Figure 22-16 on page 373 shows a control read transaction. The USBB has to manage the simultaneous write requests from the CPU and the USB host.

Figure 22-16. Control Read

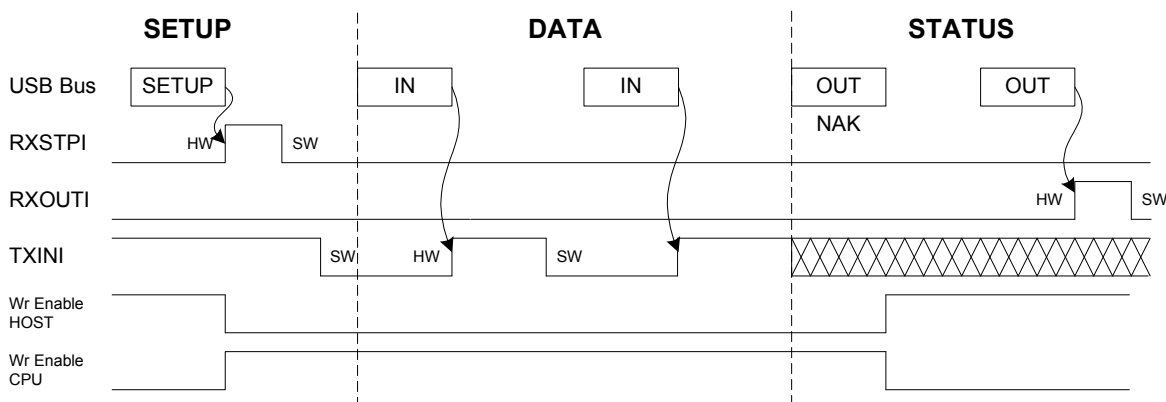

A NAK handshake is always generated on the first status stage command.

When the controller detects the status stage, all the data written by the CPU are lost and clearing TXINI has no effect.

The user checks if the transmission or the reception is complete.

The OUT retry is always ACKed. This reception sets RXOUTI and TXINI. Handle this with the following software algorithm:

```

set TXINI
wait for RXOUTI OR TXINI
if RXOUTI, then clear bit and return
if TXINI, then continue
    
```

Once the OUT status stage has been received, the USBB waits for a SETUP request. The SETUP request has priority over any other request and has to be ACKed. This means that any other bit should be cleared and the FIFO reset when a SETUP is received.

The user has to take care of the fact that the byte counter is reset when a zero-length OUT packet is received.

22.7.2.12 Management of IN endpoints

•Overview

IN packets are sent by the USB device controller upon IN requests from the host. All the data can be written which acknowledges or not the bank when it is full.

The endpoint must be configured first.

The TXINI bit is set at the same time as FIFOCON when the current bank is free. This triggers an EPnINT interrupt if the Transmitted IN Data Interrupt Enable (TXINE) bit in UECONn is one.

TXINI shall be cleared by software (by writing a one to the Transmitted IN Data Interrupt Enable Clear bit in the Endpoint n Control Clear register (UECONnCLR.TXINIC)) to acknowledge the interrupt, what has no effect on the endpoint FIFO.

The user then writes into the FIFO (see ["USB Pipe/Endpoint n FIFO Data Register \(USBFIFO-n-DATA\)" on page 471](#)) and write a one to the FIFO Control Clear (FIFOCONC) bit in UECONnCLR to clear the FIFOCON bit. This allows the USBB to send the data. If the IN endpoint is composed of multiple banks, this also switches to the next bank. The TXINI and FIFOCON bits are updated in accordance with the status of the next bank.

TXINI shall always be cleared before clearing FIFOCON.

The RWALL bit is set when the current bank is not full, i.e. the software can write further data into the FIFO.

Figure 22-17. Example of an IN Endpoint with 1 Data Bank

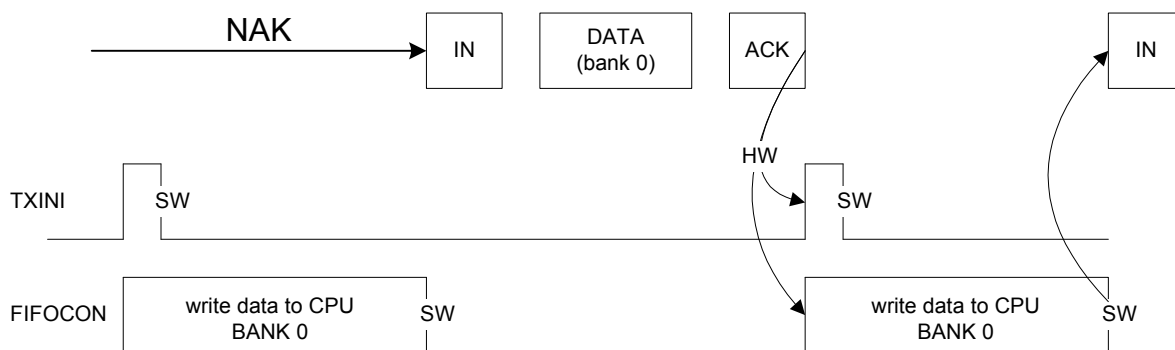
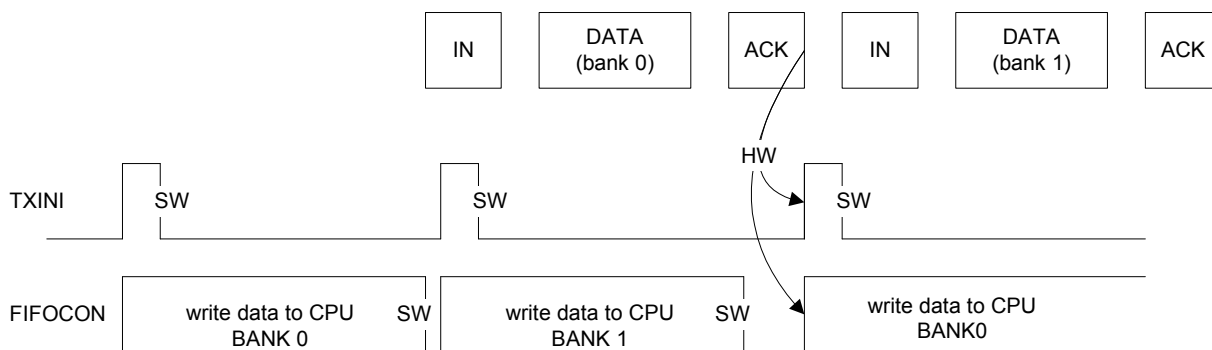

Figure 22-18. Example of an IN Endpoint with 2 Data Banks



•Detailed description

The data is written, following the next flow:

- When the bank is empty, TXINI and FIFOCON are set, what triggers an EPnINT interrupt if TXINE is one.
- The user acknowledges the interrupt by clearing TXINI.
- The user writes the data into the current bank by using the USB Pipe/Endpoint nFIFO Data virtual segment (see "USB Pipe/Endpoint n FIFO Data Register (USBFIFO n DATA)" on page 471), until all the data frame is written or the bank is full (in which case RWALL is cleared and the Byte Count (BYCT) field in UESTAn reaches the endpoint size).
- The user allows the controller to send the bank and switches to the next bank (if any) by clearing FIFOCON.

If the endpoint uses several banks, the current one can be written while the previous one is being read by the host. Then, when the user clears FIFOCON, the following bank may already be free and TXINI is set immediately.

An "Abort" stage can be produced when a zero-length OUT packet is received during an IN stage of a control or isochronous IN transaction. The Kill IN Bank (KILLBK) bit in UECONn is used to kill the last written bank. The best way to manage this abort is to apply the algorithm represented on Figure 22-19 on page 376. See "Endpoint n Control Register" on page 432 to have more details about the KILLBK bit.

Figure 22-19. Abort Algorithm

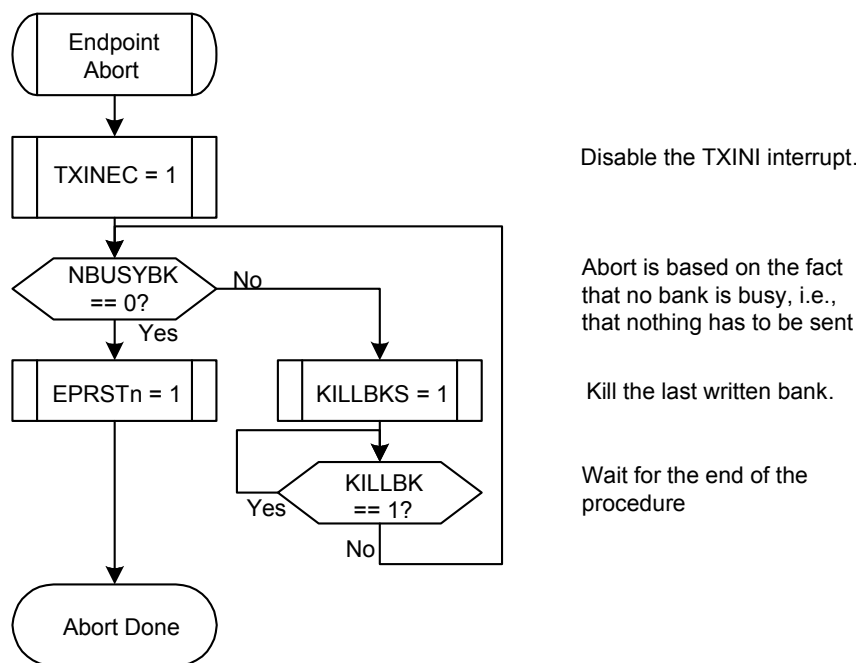

22.7.2.13 Management of OUT endpoints

•Overview

OUT packets are sent by the host. All the data can be read which acknowledges or not the bank when it is empty.

The endpoint must be configured first.

The RXOUTI bit is set at the same time as FIFOCON when the current bank is full. This triggers an EPnINT interrupt if the Received OUT Data Interrupt Enable (RXOUTE) bit in UECONn is one.

RXOUTI shall be cleared by software (by writing a one to the Received OUT Data Interrupt Clear (RXOUTIC) bit) to acknowledge the interrupt, what has no effect on the endpoint FIFO.

The user then reads from the FIFO (see "USB Pipe/Endpoint n FIFO Data Register (USBFIFO-DATA)" on page 471) and clears the FIFOCON bit to free the bank. If the OUT endpoint is composed of multiple banks, this also switches to the next bank. The RXOUTI and FIFOCON bits are updated in accordance with the status of the next bank.

RXOUTI shall always be cleared before clearing FIFOCON.

The RWALL bit is set when the current bank is not empty, i.e. the software can read further data from the FIFO.

Figure 22-20. Example of an OUT Endpoint with one Data Bank

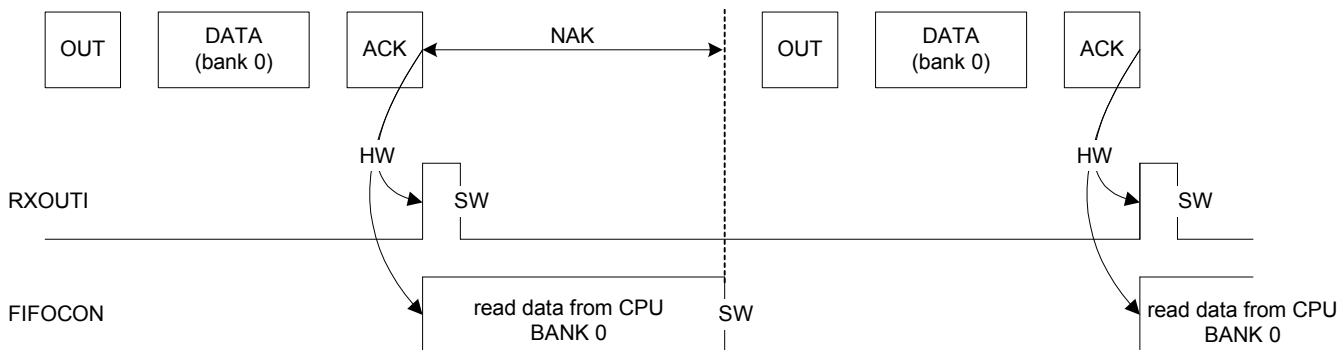
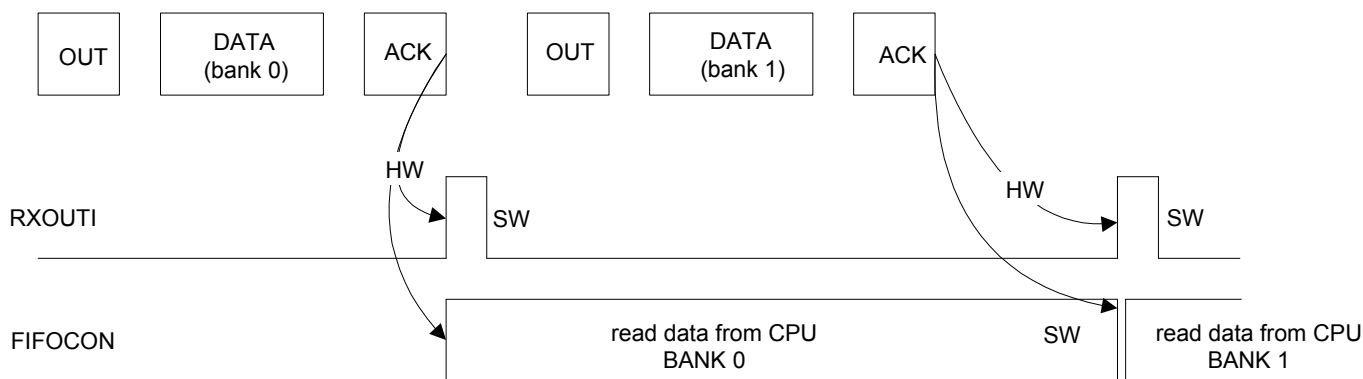

Figure 22-21. Example of an OUT Endpoint with two Data Banks



•Detailed description

The data is read, following the next flow:

- When the bank is full, RXOUTI and FIFOCON are set, what triggers an EPnINT interrupt if RXOUTE is one.
- The user acknowledges the interrupt by writing a one to RXOUTIC in order to clear RXOUTI.
- The user can read the byte count of the current bank from BYCT to know how many bytes to read, rather than polling RWALL.
- The user reads the data from the current bank by using the USBFIFO n DATA register (see ["USB Pipe/Endpoint n FIFO Data Register \(USBFIFO n DATA\)" on page 471](#)), until all the expected data frame is read or the bank is empty (in which case RWALL is cleared and BYCT reaches zero).
- The user frees the bank and switches to the next bank (if any) by clearing FIFOCON.

If the endpoint uses several banks, the current one can be read while the following one is being written by the host. Then, when the user clears FIFOCON, the following bank may already be ready and RXOUTI is set immediately.

22.7.2.14 Underflow

This error exists only for isochronous IN/OUT endpoints. It sets the Underflow Interrupt (UNDERFI) bit in UESTAn, which triggers an EPnINT interrupt if the Underflow Interrupt Enable (UNDERFE) bit is one.

An underflow can occur during IN stage if the host attempts to read from an empty bank. A zero-length packet is then automatically sent by the USBB.

An underflow can not occur during OUT stage on a CPU action, since the user may read only if the bank is not empty (RXOUTI is one or RWALL is one).

An underflow can also occur during OUT stage if the host sends a packet while the bank is already full. Typically, the CPU is not fast enough. The packet is lost.

An underflow can not occur during IN stage on a CPU action, since the user may write only if the bank is not full (TXINI is one or RWALL is one).

22.7.2.15 Overflow

This error exists for all endpoint types. It sets the Overflow interrupt (OVERFI) bit in UESTAn, which triggers an EPnINT interrupt if the Overflow Interrupt Enable (OVERFE) bit is one.

An overflow can occur during OUT stage if the host attempts to write into a bank that is too small for the packet. The packet is acknowledged and the RXOUTI bit is set as if no overflow had occurred. The bank is filled with all the first bytes of the packet that fit in.

An overflow can not occur during IN stage on a CPU action, since the user may write only if the bank is not full (TXINI is one or RWALL is one).

22.7.2.16 CRC error

This error exists only for isochronous OUT endpoints. It sets the CRC Error Interrupt (CRCERRI) bit in UESTAn, which triggers an EPnINT interrupt if the CRC Error Interrupt Enable (CRCERRE) bit is one.

A CRC error can occur during OUT stage if the USBB detects a corrupted received packet. The OUT packet is stored in the bank as if no CRC error had occurred (RXOUTI is set).

22.7.2.17 Interrupts

See the structure of the USB device interrupt system on [Figure 22-6 on page 361](#).

There are two kinds of device interrupts: processing, i.e. their generation is part of the normal processing, and exception, i.e. errors (not related to CPU exceptions).

•Global interrupts

The processing device global interrupts are:

- The Suspend (SUSP) interrupt
- The Start of Frame (SOF) interrupt with no frame number CRC error (the Frame Number CRC Error (FNCERR) bit in the Device Frame Number (UDFNUM) register is zero)
- The End of Reset (EORST) interrupt
- The Wake-Up (WAKEUP) interrupt
- The End of Resume (EORSM) interrupt

- The Upstream Resume (UPRSM) interrupt
- The Endpoint n (EPnINT) interrupt
- The DMA Channel n (DMAnINT) interrupt

The exception device global interrupts are:

- The Start of Frame (SOF) interrupt with a frame number CRC error (FNCERR is one)

•Endpoint interrupts

The processing device endpoint interrupts are:

- The Transmitted IN Data Interrupt (TXINI)
- The Received OUT Data Interrupt (RXOUTI)
- The Received SETUP Interrupt (RXSTPI)
- The Short Packet (SHORTPACKET) interrupt
- The Number of Busy Banks (NBUSYBK) interrupt

The exception device endpoint interrupts are:

- The Underflow Interrupt (UNDERFI)
- The NAKed OUT Interrupt (NAKOUTI)
- The NAKed IN Interrupt (NAKINI)
- The Overflow Interrupt (OVERFI)
- The STALLED Interrupt (STALLEDI)
- The CRC Error Interrupt (CRCERRI)

•DMA interrupts

The processing device DMA interrupts are:

- The End of USB Transfer Status (EOTSTA) interrupt
- The End of Channel Buffer Status (EOCHBUFFSTA) interrupt
- The Descriptor Loaded Status (DESCLDSTA) interrupt

There is no exception device DMA interrupt.

22.7.3 USB Host Operation

22.7.3.1 Description of pipes

For the USBB in host mode, the term “pipe” is used instead of “endpoint” (used in device mode). A host pipe corresponds to a device endpoint, as described by the Figure 22-22 on page 380 from the USB specification.

Figure 22-22. USB Communication Flow

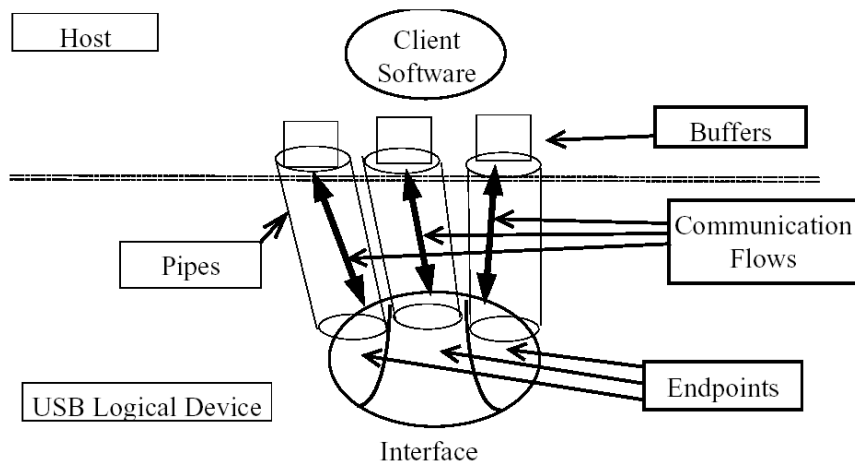

In host mode, the USBB associates a pipe to a device endpoint, considering the device configuration descriptors.

22.7.3.2 Power-On and reset

Figure 22-23 on page 380 describes the USBB host mode main states.

Figure 22-23. Host Mode States

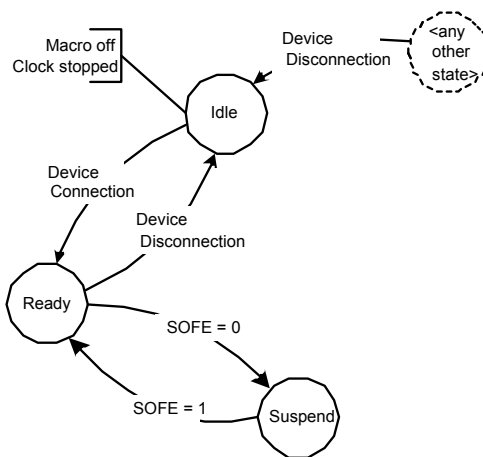

After a hardware reset, the USBB host mode is in the Reset state.

When the USBB is enabled (USBE is one) in host mode (ID is zero), its host mode state goes to the Idle state. In this state, the controller waits for device connection with minimal power con-

sumption. The USB pad should be in the Idle state. Once a device is connected, the macro enters the Ready state, what does not require the USB clock to be activated.

The controller enters the Suspend state when the USB bus is in a “Suspend” state, i.e., when the host mode does not generate the “Start of Frame (SOF)”. In this state, the USB consumption is minimal. The host mode exits the Suspend state when starting to generate the SOF over the USB line.

22.7.3.3 Device detection

A device is detected by the USBB host mode when D+ or D- is no longer tied low, i.e., when the device D+ or D- pull-up resistor is connected. To enable this detection, the host controller has to provide the VBus power supply to the device by setting the VBUSRQ bit (by writing a one to the VBUSRQS bit).

The device disconnection is detected by the host controller when both D+ and D- are pulled down.

22.7.3.4 USB reset

The USBB sends a USB bus reset when the user write a one to the Send USB Reset bit in the Host General Control register (UHCON.RESET). The USB Reset Sent Interrupt bit in the Host Global Interrupt register (UHINT.RSTI) is set when the USB reset has been sent. In this case, all the pipes are disabled and de-allocated.

If the bus was previously in a “Suspend” state (the Start of Frame Generation Enable (SOFE) bit in UHCON is zero), the USBB automatically switches it to the “Resume” state, the Host Wake-Up Interrupt (HWUPI) bit in UHINT is set and the SOFE bit is set in order to generate SOFs immediately after the USB reset.

22.7.3.5 Pipe reset

A pipe can be reset at any time by writing a one to the Pipe n Reset (PRSTn) bit in the UPRST register. This is recommended before using a pipe upon hardware reset or when a USB bus reset has been sent. This resets:

- The internal state machine of this pipe
- The receive and transmit bank FIFO counters
- All the registers of this pipe (UPCFGn, UPSTAn, UPCONn), except its configuration (ALLOC, PBK, PSIZE, PTOKEN, PTYPE, PEPNUM, INTFRQ in UPCFGn) and its Data Toggle Sequence field in the Pipe n Status register (UPSTAn.DTSEQ).

The pipe configuration remains active and the pipe is still enabled.

The pipe reset may be associated with a clear of the data toggle sequence. This can be achieved by setting the Reset Data Toggle bit in the Pipe n Control register (UPCONn.RSTDT) (by writing a one to the Reset Data Toggle Set bit in the Pipe n Control Set register (UPCONnSET.RSTDTS)).

In the end, the user has to write a zero to the PRSTn bit to complete the reset operation and to start using the FIFO.

22.7.3.6 Pipe activation

The pipe is maintained inactive and reset (see [Section 22.7.3.5](#) for more details) as long as it is disabled (PENn is zero). The Data Toggle Sequence field (DTSEQ) is also reset.

The algorithm represented on [Figure 22-24 on page 382](#) must be followed in order to activate a pipe.

Figure 22-24. Pipe Activation Algorithm

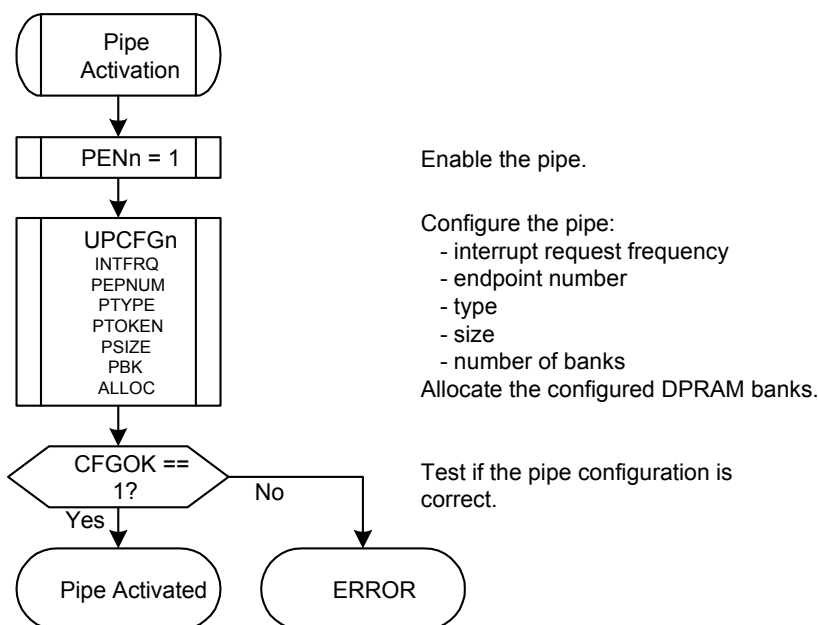

As long as the pipe is not correctly configured (UPSTAn.CFGOK is zero), the controller can not send packets to the device through this pipe.

The UPSTAn.CFGOK bit is set only if the configured size and number of banks are correct compared to their maximal allowed values for the pipe (see [Table 22-1 on page 352](#)) and to the maximal FIFO size (i.e. the DPRAM size).

See [Section 22.7.1.6](#) for more details about DPRAM management.

Once the pipe is correctly configured (UPSTAn.CFGOK is zero), only the PTOKEN and INTFRQ fields can be written by software. INTFRQ is meaningless for non-interrupt pipes.

When starting an enumeration, the user gets the device descriptor by sending a GET_DESCRIPTOR USB request. This descriptor contains the maximal packet size of the device default control endpoint (bMaxPacketSize0) and the user re-configures the size of the default control pipe with this size parameter.

22.7.3.7 Address setup

Once the device has answered the first host requests with the default device address 0, the host assigns a new address to the device. The host controller has to send an USB reset to the device and to send a SET_ADDRESS(addr) SETUP request with the new address to be used by the device. Once this SETUP transaction is over, the user writes the new address into the USB Host Address for Pipe n field in the USB Host Device Address register (UHADDR.UHADDRPn). All following requests, on all pipes, will be performed using this new address.

When the host controller sends an USB reset, the UHADDRPn field is reset by hardware and the following host requests will be performed using the default device address 0.

22.7.3.8 Remote wake-up

The controller host mode enters the Suspend state when the UHCON.SOFE bit is written to zero. No more “Start of Frame” is sent on the USB bus and the USB device enters the Suspend state 3ms later.

The device awakes the host by sending an Upstream Resume (Remote Wake-Up feature). When the host controller detects a non-idle state on the USB bus, it set the Host Wake-Up interrupt (HWUPI) bit in UHINT. If the non-idle bus state corresponds to an Upstream Resume (K state), the Upstream Resume Received Interrupt (RXRSMI) bit in UHINT is set. The user has to generate a Downstream Resume within 1 ms and for at least 20ms by writing a one to the Send USB Resume (RESUME) bit in UHCON. It is mandatory to write a one to UHCON.SOFE before writing a one to UHCON.RESUME to enter the Ready state, else UHCON.RESUME will have no effect.

22.7.3.9 Management of control pipes

A control transaction is composed of three stages:

- SETUP
- Data (IN or OUT)
- Status (OUT or IN)

The user has to change the pipe token according to each stage.

For the control pipe, and only for it, each token is assigned a specific initial data toggle sequence:

- SETUP: Data0
- IN: Data1
- OUT: Data1

22.7.3.10 Management of IN pipes

IN packets are sent by the USB device controller upon IN requests from the host. All the data can be read which acknowledges or not the bank when it is empty.

The pipe must be configured first.

When the host requires data from the device, the user has to select beforehand the IN request mode with the IN Request Mode bit in the Pipe n IN Request register (UPINRQn.INMODE):

- When INMODE is written to zero, the USBB will perform (INRQ + 1) IN requests before freezing the pipe.
- When INMODE is written to one, the USBB will perform IN requests endlessly when the pipe is not frozen by the user.

The generation of IN requests starts when the pipe is unfrozen (the Pipe Freeze (PFREEZE) field in UPCONn is zero).

The Received IN Data Interrupt (RXINI) bit in UPSTAn is set at the same time as the FIFO Control (FIFOCON) bit in UPCONn when the current bank is full. This triggers a PnINT interrupt if the Received IN Data Interrupt Enable (RXINE) bit in UPCONn is one.

RXINI shall be cleared by software (by writing a one to the Received IN Data Interrupt Clear bit in the Pipe n Control Clear register(UPCONnCLR.RXINIC)) to acknowledge the interrupt, what has no effect on the pipe FIFO.

The user then reads from the FIFO (see "USB Pipe/Endpoint n FIFO Data Register (USBFIFO_n-DATA)" on page 471) and clears the FIFOCON bit (by writing a one to the FIFO Control Clear (FIFOCONC) bit in UPCON_nCLR) to free the bank. If the IN pipe is composed of multiple banks, this also switches to the next bank. The RXINI and FIFOCON bits are updated in accordance with the status of the next bank.

RXINI shall always be cleared before clearing FIFOCON.

The Read/Write Allowed (RWALL) bit in UPSTAN is set when the current bank is not empty, i.e., the software can read further data from the FIFO.

Figure 22-25. Example of an IN Pipe with 1 Data Bank

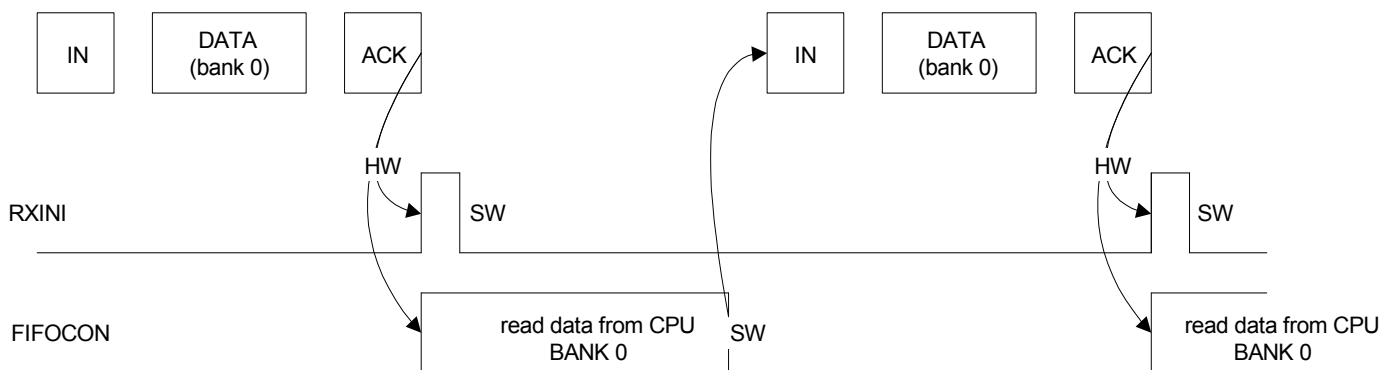
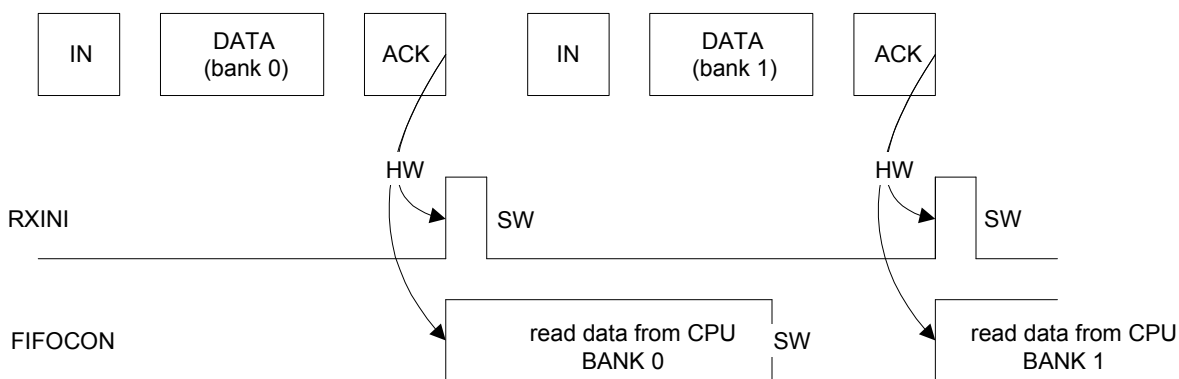

Figure 22-26. Example of an IN Pipe with 2 Data Banks



22.7.3.11 Management of OUT pipes

OUT packets are sent by the host. All the data can be written which acknowledges or not the bank when it is full.

The pipe must be configured and unfrozen first.

The Transmitted OUT Data Interrupt (TXOUTI) bit in UPSTAN is set at the same time as FIFOCON when the current bank is free. This triggers a PnINT interrupt if the Transmitted OUT Data Interrupt Enable (TXOUTE) bit in UPCON_n is one.

TXOUTI shall be cleared by software (by writing a one to the Transmitted OUT Data Interrupt Clear (TXOUTIC) bit in UPCONnCLR) to acknowledge the interrupt, what has no effect on the pipe FIFO.

The user then writes into the FIFO (see "USB Pipe/Endpoint n FIFO Data Register (USBFIFO_n-DATA)" on page 471) and clears the FIFOCON bit to allow the USBB to send the data. If the OUT pipe is composed of multiple banks, this also switches to the next bank. The TXOUTI and FIFOCON bits are updated in accordance with the status of the next bank.

TXOUTI shall always be cleared before clearing FIFOCON.

The UPSTAn.RWALL bit is set when the current bank is not full, i.e., the software can write further data into the FIFO.

Note that if the user decides to switch to the Suspend state (by writing a zero to the UHCON.SOFE bit) while a bank is ready to be sent, the USBB automatically exits this state and the bank is sent.

Figure 22-27. Example of an OUT Pipe with one Data Bank

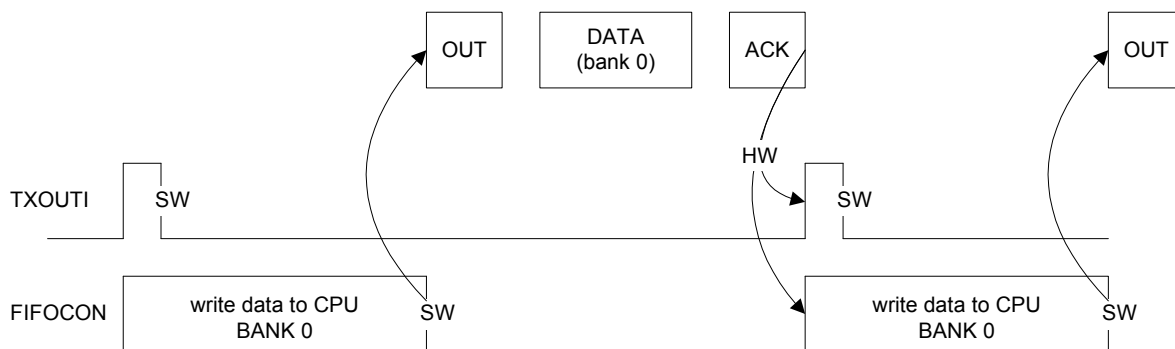

Figure 22-28. Example of an OUT Pipe with two Data Banks and no Bank Switching Delay

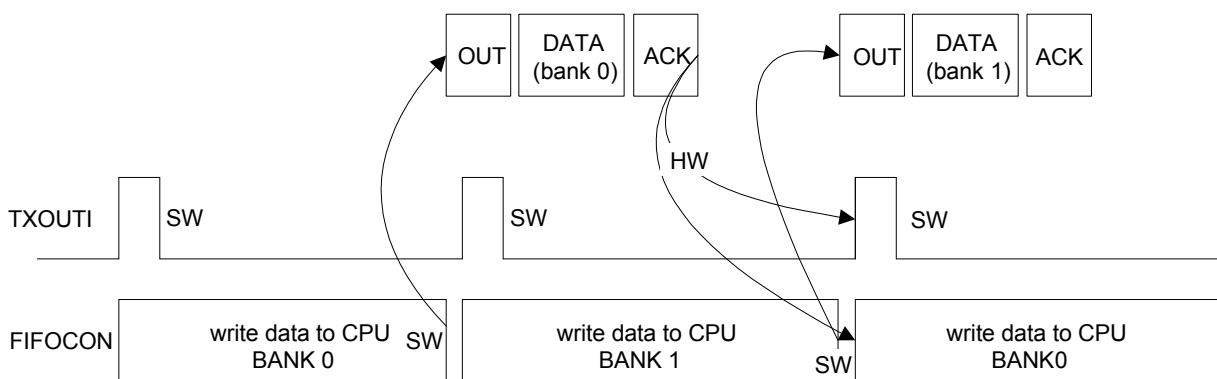
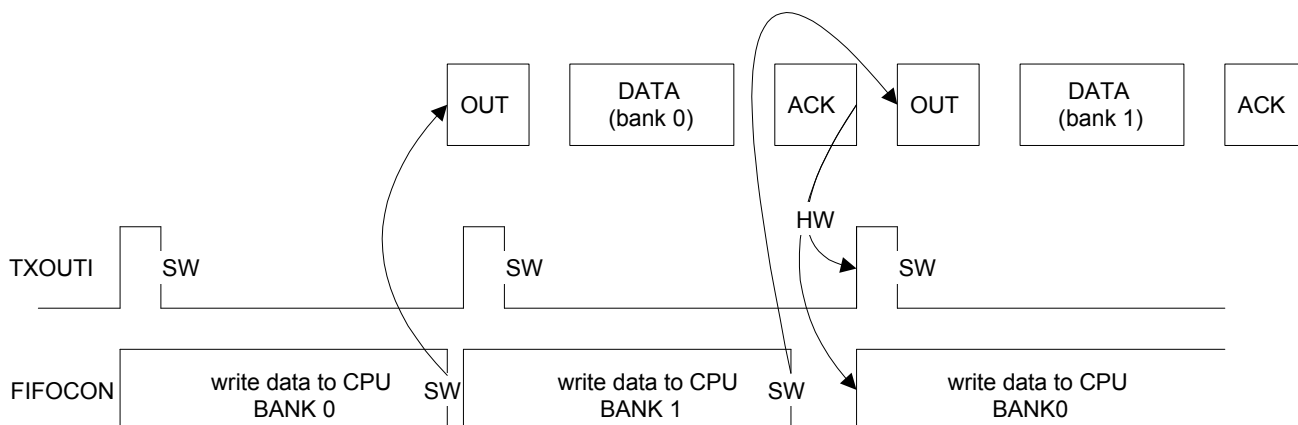

Figure 22-29. Example of an OUT Pipe with two Data Banks and a Bank Switching Delay



22.7.3.12 CRC error

This error exists only for isochronous IN pipes. It sets the CRC Error Interrupt (CRCERRI) bit, which triggers a PnINT interrupt if then the CRC Error Interrupt Enable (CRCERRE) bit in UPCONn is one.

A CRC error can occur during IN stage if the USBB detects a corrupted received packet. The IN packet is stored in the bank as if no CRC error had occurred (RXINI is set).

22.7.3.13 Interrupts

See the structure of the USB host interrupt system on [Figure 22-6 on page 361](#).

There are two kinds of host interrupts: processing, i.e. their generation is part of the normal processing, and exception, i.e. errors (not related to CPU exceptions).

•Global interrupts

The processing host global interrupts are:

- The Device Connection Interrupt (DCONNI)
- The Device Disconnection Interrupt (DDISCI)
- The USB Reset Sent Interrupt (RSTI)
- The Downstream Resume Sent Interrupt (RSMEDI)
- The Upstream Resume Received Interrupt (RXRSMI)
- The Host Start of Frame Interrupt (HSOFI)
- The Host Wake-Up Interrupt (HWUPI)
- The Pipe n Interrupt (PnINT)
- The DMA Channel n Interrupt (DMAINT)

There is no exception host global interrupt.

•Pipe interrupts

The processing host pipe interrupts are:

- The Received IN Data Interrupt (RXINI)

- The Transmitted OUT Data Interrupt (TXOUTI)
- The Transmitted SETUP Interrupt (TXSTPI)
- The Short Packet Interrupt (SHORTPACKETI)
- The Number of Busy Banks (NBUSYBK) interrupt

The exception host pipe interrupts are:

- The Underflow Interrupt (UNDERFI)
- The Pipe Error Interrupt (PERRI)
- The NAKed Interrupt (NAKEDI)
- The Overflow Interrupt (OVERFI)
- The Received STALLed Interrupt (RXSTALLDI)
- The CRC Error Interrupt (CRCERRI)

•*DMA interrupts*

The processing host DMA interrupts are:

- The End of USB Transfer Status (EOTSTA) interrupt
- The End of Channel Buffer Status (EOCHBUFFSTA) interrupt
- The Descriptor Loaded Status (DESCLDSTA) interrupt

There is no exception host DMA interrupt.

22.7.4 USB DMA Operation

22.7.4.1 Introduction

USB packets of any length may be transferred when required by the USBB. These transfers always feature sequential addressing. These two characteristics mean that in case of high USBB throughput, both HSB ports will benefit from “incrementing burst of unspecified length” since the average access latency of HSB slaves can then be reduced.

The DMA uses word “incrementing burst of unspecified length” of up to 256 beats for both data transfers and channel descriptor loading. A burst may last on the HSB busses for the duration of a whole USB packet transfer, unless otherwise broken by the HSB arbitration or the HSB 1kbyte boundary crossing.

Packet data HSB bursts may be locked on a DMA buffer basis for drastic overall HSB bus bandwidth performance boost with paged memories. This is because these memories row (or bank) changes, which are very clock-cycle consuming, will then likely not occur or occur once instead of dozens of times during a single big USB packet DMA transfer in case other HSB masters address the memory. This means up to 128 words single cycle unbroken HSB bursts for bulk pipes/endpoints and 256 words single cycle unbroken bursts for isochronous pipes/endpoints. This maximal burst length is then controlled by the lowest programmed USB pipe/endpoint size (PSIZE/EPSIZE) and the Channel Byte Length (CHBYTELENGTH) field in the Device DMA Channel n Control (UDDMANCONTROL) register.

The USBB average throughput may be up to nearly 12Mbit/s. Its average access latency decreases as burst length increases due to the zero wait-state side effect of unchanged pipe/endpoint. Word access allows reducing the HSB bandwidth required for the USB by four compared to native byte access. If at least 0 wait-state word burst capability is also provided by the other DMA HSB bus slaves, each of both DMA HSB busses need less than 1.1% bandwidth allocation for full USB bandwidth usage at 33MHz, and less than 0.6% at 66MHz.

Figure 22-30. Example of DMA Chained List

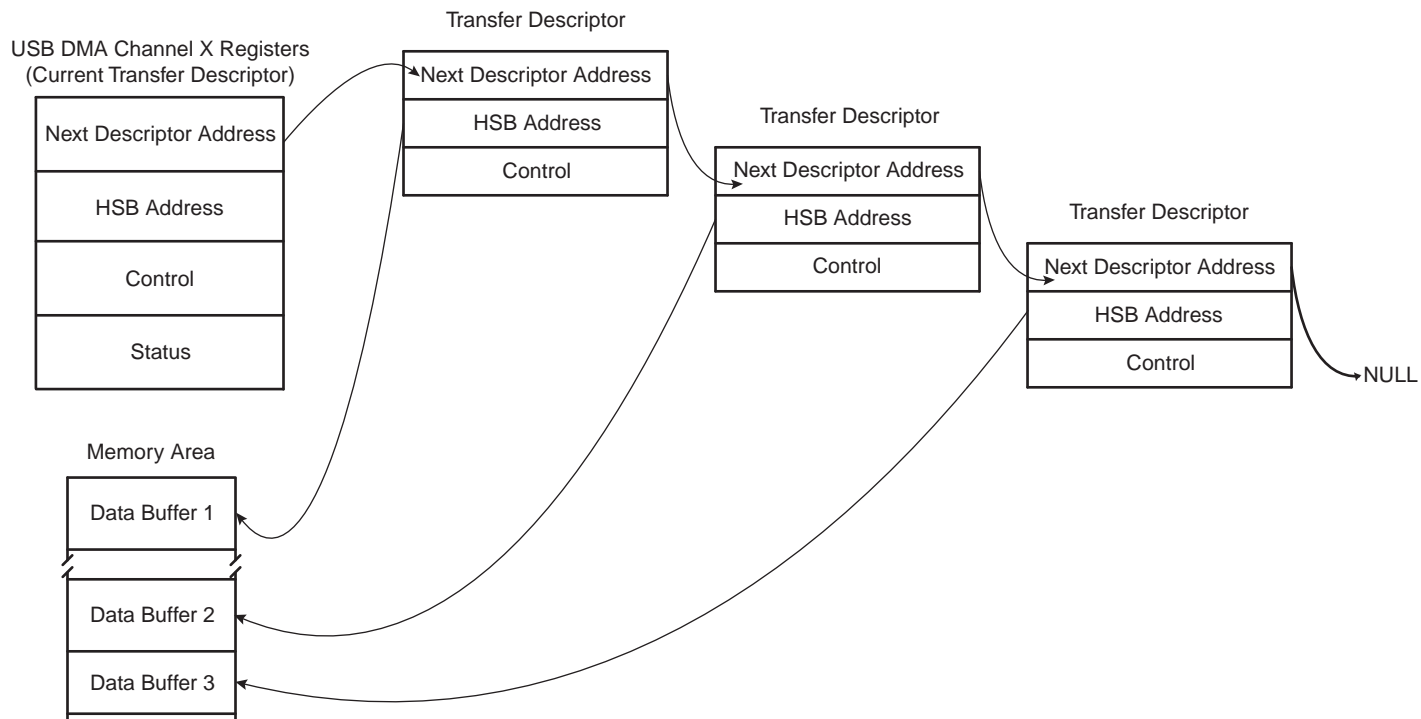

22.7.4.2 DMA Channel descriptor

The DMA channel transfer descriptor is loaded from the memory.

Be careful with the alignment of this buffer.

The structure of the DMA channel transfer descriptor is defined by three parameters as described below:

- Offset 0:
 - The address must be aligned: 0xXXXX0
 - DMA Channel n Next Descriptor Address Register: `DMA nNEXTDESCADDR`
- Offset 4:
 - The address must be aligned: 0xXXXX4
 - DMA Channel n HSB Address Register: `DMA nADDR`
- Offset 8:
 - The address must be aligned: 0xXXXX8
 - DMA Channel n Control Register: `DMA nCONTROL`

22.7.4.3 Programming a channel:

Each DMA transfer is unidirectional. Direction depends on the type of the associated endpoint (IN or OUT).

Three registers, the `UDDMA nNEXTDESC`, the `UDDMA nADDR` and `UDDMA nCONTROL` need to be programmed to set up whether single or multiple transfer is used.

The following example refers to OUT endpoint. For IN endpoint, the programming is symmetric.

•*Single-block transfer programming example for OUT transfer :*

The following sequence may be used:

- Configure the targeted endpoint (source) as OUT type, and set the automatic bank switching for this endpoint in the UECFGn register to handle multiple OUT packet.
- Write the starting destination address in the UDDMANADDR register.
- There is no need to program the UDDMANNEXTDESC register.
- Program the channel byte length in the UDDMANCONTROL register.
- Program the UDDMANCONTROL according to Row 2 as shown in [Figure 22-6 on page 439](#) to set up a single block transfer.

The UDDMANSTATUS.CHEN bit is set indicating that the dma channel is enable.

As soon as an OUT packet is stored inside the endpoint, the UDDMANSTATUS.CHACTIVE bit is set to one, indicating that the DMA channel is transferring data from the endpoint to the destination address until the endpoint is empty or the channel byte length is reached. Once the endpoint is empty, the UDDMANSTATUS.CHACTIVE bit is cleared.

Once the DMA channel is completed (i.e : the channel byte length is reached), after one or multiple processed OUT packet, the UDDMANCONTROL.CHEN bit is cleared. As a consequence, the UDDMANSTATUS.CHEN bit is also cleared, and the UDDMANSTATUS.EOCHBUFFSTA bit is set indicating a end of dma channel. If the UDDMANCONTROL.DMAENDEN bit was set, the last endpoint bank will be properly released even if there are some residual datas inside, i.e: OUT packet truncation at the end of DMA buffer when the dma channel byte length is not an integral multiple of the endpoint size.

•*Programming example for single-block dma transfer with automatic closure for OUT transfer :*

The idea is to automatically close the DMA transfer at the end of the OUT transaction (received short packet). The following sequence may be used:

- Configure the targeted endpoint (source) as OUT type, and set the automatic bank switching for this endpoint in the UECFGn register to handle multiple OUT packet.
- Write the starting destination address in the UDDMANADDR register.
- There is no need to program the UDDMANNEXTDESC register.
- Program the channel byte length in the UDDMANCONTROL register.
- Set the BUFFCLOSEINEN bit in the UDDMANCONTROL register.
- Program the UDDMANCONTROL according to Row 2 as shown in [Figure 22-6 on page 439](#) to set up a single block transfer.

As soon as an OUT packet is stored inside the endpoint, the UDDMANSTATUS.CHACTIVE bit is set to one, indicating that the DMA channel is transferring data from the endpoint to the destination address until the endpoint is empty. Once the endpoint is empty, the UDDMANSTATUS.CHACTIVE bit is cleared.

After one or multiple processed OUT packet, the DMA channel is completed after sourcing a short packet. Then, the UDDMANCONTROL.CHEN bit is cleared. As a consequence, after a few cycles latency, the UDDMANSTATUS.CHEN bit is also cleared, and the UDDMANSTATUS.EOTSTA bit is set indicating that the DMA was closed by a end of USB transaction.

•*Programming example for multi-block dma transfer : run and link at end of buffer*

The idea is to run first a single block transfer followed automatically by a linked list of DMA. The following sequence may be used:

- Configure the targeted endpoint (source) as OUT type, and set the automatic bank switching for this endpoint in the UECFGn register to handle multiple OUT packet.
- Set up the chain of linked list of descriptor in memory. Each descriptor is composed of 3 items : channel next descriptor address, channel destination address and channel control. The last descriptor should be programmed according to row 2 as shown in [Figure 22-6 on page 439](#).
- Write the starting destination address in the UDDMAnADDR register.
- Program the UDDMAnNEXTDESC register.
- Program the channel byte length in the UDDMAnCONTROL register.
- Optionnaly set the BUFFCLOSEINEN bit in the UDDMAnCONTROL register.
- Program the UDDMAnCONTROL according to Row 4 as shown in [Figure 22-6 on page 439](#).

The UDDMAnSTATUS.CHEN bit is set indicating that the dma channel is enable.

As soon as an OUT packet is stored inside the endpoint, the UDDMAnSTATUS.CHACTIVE bit is set to one, indicating that the DMA channel is transferring data from the endpoint to the destination address until the endpoint is empty or the channel byte length is reached. Once the endpoint is empty, the UDDMAnSTATUS.CHACTIVE bit is cleared.

Once the first DMA channel is completed (i.e : the channel byte length is reached), after one or multiple processed OUT packet, the UDDMAnCONTROL.CHEN bit is cleared. As a consequence, the UDDMAnSTATUS.CHEN bit is also cleared, and the UDDMAnSTATUS.EOCHBUFFSTA bit is set indicating a end of dma channel. If the UDDMAnCONTROL.DMAENDEN bit was set, the last endpoint bank will be properly released even if there are some residual datas inside, i.e: OUT packet truncation at the end of DMA buffer when the dma channel byte lenght is not an integral multiple of the endpoint size. Note that the UDDMAnCONTROL.LDNXTCH bit remains to one indicating that a linked descriptor will be loaded.

Once the new descriptor is loaded from the UDDMAnNEXTDESC memory address, the UDDMAnSTATUS.DESCLDSTA bit is set, and the UDDMAnCONTROL register is updated from the memory. As a consequence, the UDDMAnSTATUS.CHEN bit is set, and the UDDMAnSTATUS.CHACTIVE is set as soon as the endpoint is ready to be sourced by the DMA (received OUT data packet).

This sequence is repeated until a last linked descriptor is processed. The last descriptor is detected according to row 2 as shown in [Figure 22-6 on page 439](#).

At the end of the last descriptor, the UDDMAnCONTROL.CHEN bit is cleared. As a consequence, after a few cycles latency, the UDDMAnSTATUS.CHEN bit is also cleared.

•*Programming example for multi-block dma transfer : load next descriptor now*

The idea is to directly run first a linked list of DMA. The following sequence may be used: The following sequence may be used:

- Configure the targeted endpoint (source) as OUT type, and set the automatic bank switching for this endpoint in the UECFGn register to handle multiple OUT packet.

- Set up the chain of linked list of descriptor in memory. Each descriptor is composed of 3 items : channel next descriptor address, channel destination address and channel control. The last descriptor should be programmed according to row 2 as shown in [Figure 22-6 on page 439](#).
- Program the UDDMAnNEXTDESC register.
- Program the UDDMAnCONTROL according to Row 3 as shown in [Figure 22-6 on page 439](#).

The UDDMAnSTATUS.CHEN bit is 0 and the UDDMAnSTATUS.LDNXTCHDESCEN is set indicating that the DMA channel is pending until the endpoint is ready (received OUT packet).

As soon as an OUT packet is stored inside the endpoint, the UDDMAnSTATUS.CHACTIVE bit is set to one. Then after a few cycle latency, the new descriptor is loaded from the memory and the UDDMAnSTATUS.DESCLDSTA is set.

At the end of this DMA (for instance when the channel byte length has reached 0), the UDDMAnCONTROL.CHEN bit is cleared, and then the UDDMAnSTATUS.CHEN bit is also cleared. If the UDDMAnCONTROL.LDNXTCH value is one, a new descriptor is loaded.

This sequence is repeated until a last linked descriptor is processed. The last descriptor is detected according to row 2 as shown in [Figure 22-6 on page 439](#).

At the end of the last descriptor, the UDDMAnCONTROL.CHEN bit is cleared. As a consequence, after a few cycles latency, the UDDMAnSTATUS.CHEN bit is also cleared.

22.8 User Interface

Table 22-4. USBB Register Memory Map

| Offset | Register | Name | Access | Reset Value |
|--------|---|-----------|------------|-------------|
| 0x0000 | Device General Control Register | UDCON | Read/Write | 0x00000100 |
| 0x0004 | Device Global Interrupt Register | UDINT | Read-Only | 0x00000000 |
| 0x0008 | Device Global Interrupt Clear Register | UDINTCLR | Write-Only | 0x00000000 |
| 0x000C | Device Global Interrupt Set Register | UDINTSET | Write-Only | 0x00000000 |
| 0x0010 | Device Global Interrupt Enable Register | UDINTE | Read-Only | 0x00000000 |
| 0x0014 | Device Global Interrupt Enable Clear Register | UDINTECLR | Write-Only | 0x00000000 |
| 0x0018 | Device Global Interrupt Enable Set Register | UDINTESET | Write-Only | 0x00000000 |
| 0x001C | Endpoint Enable/Reset Register | UERST | Read/Write | 0x00000000 |
| 0x0020 | Device Frame Number Register | UDFNUM | Read-Only | 0x00000000 |
| 0x0100 | Endpoint 0 Configuration Register | UECFG0 | Read/Write | 0x00002000 |
| 0x0104 | Endpoint 1 Configuration Register | UECFG1 | Read/Write | 0x00002000 |
| 0x0108 | Endpoint 2 Configuration Register | UECFG2 | Read/Write | 0x00002000 |
| 0x010C | Endpoint 3 Configuration Register | UECFG3 | Read/Write | 0x00002000 |
| 0x0110 | Endpoint 4 Configuration Register | UECFG4 | Read/Write | 0x00002000 |
| 0x0114 | Endpoint 5 Configuration Register | UECFG5 | Read/Write | 0x00002000 |
| 0x0118 | Endpoint 6 Configuration Register | UECFG6 | Read/Write | 0x00002000 |
| 0x0130 | Endpoint 0 Status Register | UESTA0 | Read-Only | 0x00000100 |
| 0x0134 | Endpoint 1 Status Register | UESTA1 | Read-Only | 0x00000100 |
| 0x0138 | Endpoint 2 Status Register | UESTA2 | Read-Only | 0x00000100 |
| 0x013C | Endpoint 3 Status Register | UESTA3 | Read-Only | 0x00000100 |
| 0x0140 | Endpoint 4 Status Register | UESTA4 | Read-Only | 0x00000100 |
| 0x0144 | Endpoint 5 Status Register | UESTA5 | Read-Only | 0x00000100 |
| 0x0148 | Endpoint 6 Status Register | UESTA6 | Read-Only | 0x00000100 |
| 0x0160 | Endpoint 0 Status Clear Register | UESTA0CLR | Write-Only | 0x00000000 |
| 0x0164 | Endpoint 1 Status Clear Register | UESTA1CLR | Write-Only | 0x00000000 |
| 0x0168 | Endpoint 2 Status Clear Register | UESTA2CLR | Write-Only | 0x00000000 |
| 0x016C | Endpoint 3 Status Clear Register | UESTA3CLR | Write-Only | 0x00000000 |
| 0x0170 | Endpoint 4 Status Clear Register | UESTA4CLR | Write-Only | 0x00000000 |
| 0x0174 | Endpoint 5 Status Clear Register | UESTA5CLR | Write-Only | 0x00000000 |
| 0x0178 | Endpoint 6 Status Clear Register | UESTA6CLR | Write-Only | 0x00000000 |
| 0x017C | Endpoint 7 Status Clear Register | UESTA7CLR | Write-Only | 0x00000000 |
| 0x0190 | Endpoint 0 Status Set Register | UESTA0SET | Write-Only | 0x00000000 |
| 0x0194 | Endpoint 1 Status Set Register | UESTA1SET | Write-Only | 0x00000000 |
| 0x0198 | Endpoint 2 Status Set Register | UESTA2SET | Write-Only | 0x00000000 |
| 0x019C | Endpoint 3 Status Set Register | UESTA3SET | Write-Only | 0x00000000 |

Table 22-4. USBB Register Memory Map

| Offset | Register | Name | Access | Reset Value |
|--------|---|-----------------|------------|-------------|
| 0x01A0 | Endpoint 4 Status Set Register | UESTA4SET | Write-Only | 0x00000000 |
| 0x01A4 | Endpoint 5 Status Set Register | UESTA5SET | Write-Only | 0x00000000 |
| 0x01A8 | Endpoint 6 Status Set Register | UESTA6SET | Write-Only | 0x00000000 |
| 0x01AC | Endpoint 7 Status Set Register | UESTA7SET | Write-Only | 0x00000000 |
| 0x01C0 | Endpoint 0 Control Register | UECON0 | Read-Only | 0x00000000 |
| 0x01C4 | Endpoint 1 Control Register | UECON1 | Read-Only | 0x00000000 |
| 0x01C8 | Endpoint 2 Control Register | UECON2 | Read-Only | 0x00000000 |
| 0x01CC | Endpoint 3 Control Register | UECON3 | Read-Only | 0x00000000 |
| 0x01D0 | Endpoint 4 Control Register | UECON4 | Read-Only | 0x00000000 |
| 0x01D4 | Endpoint 5 Control Register | UECON5 | Read-Only | 0x00000000 |
| 0x01D8 | Endpoint 6 Control Register | UECON6 | Read-Only | 0x00000000 |
| 0x01DC | Endpoint 7 Control Register | UECON7 | Read-Only | 0x00000000 |
| 0x01F0 | Endpoint 0 Control Set Register | UECON0SET | Write-Only | 0x00000000 |
| 0x01F4 | Endpoint 1 Control Set Register | UECON1SET | Write-Only | 0x00000000 |
| 0x01F8 | Endpoint 2 Control Set Register | UECON2SET | Write-Only | 0x00000000 |
| 0x01FC | Endpoint 3 Control Set Register | UECON3SET | Write-Only | 0x00000000 |
| 0x0200 | Endpoint 4 Control Set Register | UECON4SET | Write-Only | 0x00000000 |
| 0x0204 | Endpoint 5 Control Set Register | UECON5SET | Write-Only | 0x00000000 |
| 0x0208 | Endpoint 6 Control Set Register | UECON6SET | Write-Only | 0x00000000 |
| 0x020C | Endpoint 7 Control Set Register | UECON7SET | Write-Only | 0x00000000 |
| 0x0220 | Endpoint 0 Control Clear Register | UECON0CLR | Write-Only | 0x00000000 |
| 0x0224 | Endpoint 1 Control Clear Register | UECON1CLR | Write-Only | 0x00000000 |
| 0x0228 | Endpoint 2 Control Clear Register | UECON2CLR | Write-Only | 0x00000000 |
| 0x022C | Endpoint 3 Control Clear Register | UECON3CLR | Write-Only | 0x00000000 |
| 0x0230 | Endpoint 4 Control Clear Register | UECON4CLR | Write-Only | 0x00000000 |
| 0x0234 | Endpoint 5 Control Clear Register | UECON5CLR | Write-Only | 0x00000000 |
| 0x0238 | Endpoint 6 Control Clear Register | UECON6CLR | Write-Only | 0x00000000 |
| 0x023C | Endpoint 7 Control Clear Register | UECON7CLR | Write-Only | 0x00000000 |
| 0x0310 | Device DMA Channel 1 Next Descriptor Address Register | UDDMA1 NEXTDESC | Read/Write | 0x00000000 |
| 0x0314 | Device DMA Channel 1 HSB Address Register | UDDMA1 ADDR | Read/Write | 0x00000000 |
| 0x0318 | Device DMA Channel 1 Control Register | UDDMA1 CONTROL | Read/Write | 0x00000000 |
| 0x031C | Device DMA Channel 1 Status Register | UDDMA1 STATUS | Read/Write | 0x00000000 |
| 0x0320 | Device DMA Channel 2 Next Descriptor Address Register | UDDMA2 NEXTDESC | Read/Write | 0x00000000 |

Table 22-4. USBB Register Memory Map

| Offset | Register | Name | Access | Reset Value |
|--------|---|-----------------|------------|-------------|
| 0x0324 | Device DMA Channel 2 HSB Address Register | UDDMA2 ADDR | Read/Write | 0x00000000 |
| 0x0328 | Device DMA Channel 2 Control Register | UDDMA2 CONTROL | Read/Write | 0x00000000 |
| 0x032C | Device DMA Channel 2 Status Register | UDDMA2 STATUS | Read/Write | 0x00000000 |
| 0x0330 | Device DMA Channel 3 Next Descriptor Address Register | UDDMA3 NEXTDESC | Read/Write | 0x00000000 |
| 0x0334 | Device DMA Channel 3 HSB Address Register | UDDMA3 ADDR | Read/Write | 0x00000000 |
| 0x0338 | Device DMA Channel 3 Control Register | UDDMA3 CONTROL | Read/Write | 0x00000000 |
| 0x033C | Device DMA Channel 3 Status Register | UDDMA3 STATUS | Read/Write | 0x00000000 |
| 0x0340 | Device DMA Channel 4 Next Descriptor Address Register | UDDMA4 NEXTDESC | Read/Write | 0x00000000 |
| 0x0344 | Device DMA Channel 4 HSB Address Register | UDDMA4 ADDR | Read/Write | 0x00000000 |
| 0x0348 | Device DMA Channel 4 Control Register | UDDMA4 CONTROL | Read/Write | 0x00000000 |
| 0x034C | Device DMA Channel 4 Status Register | UDDMA4 STATUS | Read/Write | 0x00000000 |
| 0x0350 | Device DMA Channel 5 Next Descriptor Address Register | UDDMA5 NEXTDESC | Read/Write | 0x00000000 |
| 0x0354 | Device DMA Channel 5 HSB Address Register | UDDMA5 ADDR | Read/Write | 0x00000000 |
| 0x0358 | Device DMA Channel 5 Control Register | UDDMA5 CONTROL | Read/Write | 0x00000000 |
| 0x035C | Device DMA Channel 5 Status Register | UDDMA5 STATUS | Read/Write | 0x00000000 |
| 0x0360 | Device DMA Channel 6 Next Descriptor Address Register | UDDMA6 NEXTDESC | Read/Write | 0x00000000 |
| 0x0364 | Device DMA Channel 6 HSB Address Register | UDDMA6 ADDR | Read/Write | 0x00000000 |
| 0x0368 | Device DMA Channel 6 Control Register | UDDMA6 CONTROL | Read/Write | 0x00000000 |
| 0x036C | Device DMA Channel 6 Status Register | UDDMA6 STATUS | Read/Write | 0x00000000 |
| 0x0400 | Host General Control Register | UHCON | Read/Write | 0x00000000 |
| 0x0404 | Host Global Interrupt Register | UHINT | Read-Only | 0x00000000 |
| 0x0408 | Host Global Interrupt Clear Register | UHINTCLR | Write-Only | 0x00000000 |
| 0x040C | Host Global Interrupt Set Register | UHINTSET | Write-Only | 0x00000000 |
| 0x0410 | Host Global Interrupt Enable Register | UHINTE | Read-Only | 0x00000000 |

Table 22-4. USBB Register Memory Map

| Offset | Register | Name | Access | Reset Value |
|---------|---|-----------|------------|-------------|
| 0x0414 | Host Global Interrupt Enable Clear Register | UHINTECLR | Write-Only | 0x00000000 |
| 0x0418 | Host Global Interrupt Enable Set Register | UHINTESET | Write-Only | 0x00000000 |
| 0x0041C | Pipe Enable/Reset Register | UPRST | Read/Write | 0x00000000 |
| 0x0420 | Host Frame Number Register | UHFNUM | Read/Write | 0x00000000 |
| 0x0424 | Host Address 1 Register | UHADDR1 | Read/Write | 0x00000000 |
| 0x0428 | Host Address 2 Register | UHADDR2 | Read/Write | 0x00000000 |
| 0x0500 | Pipe 0 Configuration Register | UPCFG0 | Read/Write | 0x00000000 |
| 0x0504 | Pipe 1 Configuration Register | UPCFG1 | Read/Write | 0x00000000 |
| 0x0508 | Pipe 2 Configuration Register | UPCFG2 | Read/Write | 0x00000000 |
| 0x050C | Pipe 3 Configuration Register | UPCFG3 | Read/Write | 0x00000000 |
| 0x0510 | Pipe 4 Configuration Register | UPCFG4 | Read/Write | 0x00000000 |
| 0x0514 | Pipe 5 Configuration Register | UPCFG5 | Read/Write | 0x00000000 |
| 0x0518 | Pipe 6 Configuration Register | UPCFG6 | Read/Write | 0x00000000 |
| 0x0530 | Pipe 0 Status Register | UPSTA0 | Read-Only | 0x00000000 |
| 0x0534 | Pipe 1 Status Register | UPSTA1 | Read-Only | 0x00000000 |
| 0x0538 | Pipe 2 Status Register | UPSTA2 | Read-Only | 0x00000000 |
| 0x053C | Pipe 3 Status Register | UPSTA3 | Read-Only | 0x00000000 |
| 0x0540 | Pipe 4 Status Register | UPSTA4 | Read-Only | 0x00000000 |
| 0x0544 | Pipe 5 Status Register | UPSTA5 | Read-Only | 0x00000000 |
| 0x0548 | Pipe 6 Status Register | UPSTA6 | Read-Only | 0x00000000 |
| 0x0560 | Pipe 0 Status Clear Register | UPSTA0CLR | Write-Only | 0x00000000 |
| 0x0564 | Pipe 1 Status Clear Register | UPSTA1CLR | Write-Only | 0x00000000 |
| 0x0568 | Pipe 2 Status Clear Register | UPSTA2CLR | Write-Only | 0x00000000 |
| 0x056C | Pipe 3 Status Clear Register | UPSTA3CLR | Write-Only | 0x00000000 |
| 0x0570 | Pipe 4 Status Clear Register | UPSTA4CLR | Write-Only | 0x00000000 |
| 0x0574 | Pipe 5 Status Clear Register | UPSTA5CLR | Write-Only | 0x00000000 |
| 0x0578 | Pipe 6 Status Clear Register | UPSTA6CLR | Write-Only | 0x00000000 |
| 0x0590 | Pipe 0 Status Set Register | UPSTA0SET | Write-Only | 0x00000000 |
| 0x0594 | Pipe 1 Status Set Register | UPSTA1SET | Write-Only | 0x00000000 |
| 0x0598 | Pipe 2 Status Set Register | UPSTA2SET | Write-Only | 0x00000000 |
| 0x059C | Pipe 3 Status Set Register | UPSTA3SET | Write-Only | 0x00000000 |
| 0x05A0 | Pipe 4 Status Set Register | UPSTA4SET | Write-Only | 0x00000000 |
| 0x05A4 | Pipe 5 Status Set Register | UPSTA5SET | Write-Only | 0x00000000 |
| 0x05A8 | Pipe 6 Status Set Register | UPSTA6SET | Write-Only | 0x00000000 |
| 0x05C0 | Pipe 0 Control Register | UPCON0 | Read-Only | 0x00000000 |
| 0x05C4 | Pipe 1 Control Register | UPCON1 | Read-Only | 0x00000000 |

Table 22-4. USBB Register Memory Map

| Offset | Register | Name | Access | Reset Value |
|--------|---|-----------------|------------|-------------|
| 0x05C8 | Pipe 2 Control Register | UPCON2 | Read-Only | 0x00000000 |
| 0x05CC | Pipe 3 Control Register | UPCON3 | Read-Only | 0x00000000 |
| 0x05D0 | Pipe 4 Control Register | UPCON4 | Read-Only | 0x00000000 |
| 0x05D4 | Pipe 5 Control Register | UPCON5 | Read-Only | 0x00000000 |
| 0x05D8 | Pipe 6 Control Register | UPCON6 | Read-Only | 0x00000000 |
| 0x05DC | Pipe 7 Control Register | UPCON7 | Read-Only | 0x00000000 |
| 0x05F0 | Pipe 0 Control Set Register | UPCON0SET | Write-Only | 0x00000000 |
| 0x05F4 | Pipe 1 Control Set Register | UPCON1SET | Write-Only | 0x00000000 |
| 0x05F8 | Pipe 2 Control Set Register | UPCON2SET | Write-Only | 0x00000000 |
| 0x05FC | Pipe 3 Control Set Register | UPCON3SET | Write-Only | 0x00000000 |
| 0x0600 | Pipe 4 Control Set Register | UPCON4SET | Write-Only | 0x00000000 |
| 0x0604 | Pipe 5 Control Set Register | UPCON5SET | Write-Only | 0x00000000 |
| 0x0608 | Pipe 6 Control Set Register | UPCON6SET | Write-Only | 0x00000000 |
| 0x0620 | Pipe 0 Control Clear Register | UPCON0CLR | Write-Only | 0x00000000 |
| 0x0624 | Pipe 1 Control Clear Register | UPCON1CLR | Write-Only | 0x00000000 |
| 0x0628 | Pipe 2 Control Clear Register | UPCON2CLR | Write-Only | 0x00000000 |
| 0x062C | Pipe 3 Control Clear Register | UPCON3CLR | Write-Only | 0x00000000 |
| 0x0630 | Pipe 4 Control Clear Register | UPCON4CLR | Write-Only | 0x00000000 |
| 0x0634 | Pipe 5 Control Clear Register | UPCON5CLR | Write-Only | 0x00000000 |
| 0x0638 | Pipe 6 Control Clear Register | UPCON6CLR | Write-Only | 0x00000000 |
| 0x0650 | Pipe 0 IN Request Register | UPINRQ0 | Read/Write | 0x00000000 |
| 0x0654 | Pipe 1 IN Request Register | UPINRQ1 | Read/Write | 0x00000000 |
| 0x0658 | Pipe 2 IN Request Register | UPINRQ2 | Read/Write | 0x00000000 |
| 0x065C | Pipe 3 IN Request Register | UPINRQ3 | Read/Write | 0x00000000 |
| 0x0660 | Pipe 4 IN Request Register | UPINRQ4 | Read/Write | 0x00000000 |
| 0x0664 | Pipe 5 IN Request Register | UPINRQ5 | Read/Write | 0x00000000 |
| 0x0668 | Pipe 6 IN Request Register | UPINRQ6 | Read/Write | 0x00000000 |
| 0x0680 | Pipe 0 Error Register | UPERR0 | Read/Write | 0x00000000 |
| 0x0684 | Pipe 1 Error Register | UPERR1 | Read/Write | 0x00000000 |
| 0x0688 | Pipe 2 Error Register | UPERR2 | Read/Write | 0x00000000 |
| 0x068C | Pipe 3 Error Register | UPERR3 | Read/Write | 0x00000000 |
| 0x0690 | Pipe 4 Error Register | UPERR4 | Read/Write | 0x00000000 |
| 0x0694 | Pipe 5 Error Register | UPERR5 | Read/Write | 0x00000000 |
| 0x0698 | Pipe 6 Error Register | UPERR6 | Read/Write | 0x00000000 |
| 0x0710 | Host DMA Channel 1 Next Descriptor Address Register | UHDMA1 NEXTDESC | Read/Write | 0x00000000 |

Table 22-4. USBB Register Memory Map

| Offset | Register | Name | Access | Reset Value |
|--------|---|-----------------|------------|-------------|
| 0x0714 | Host DMA Channel 1 HSB Address Register | UHDMA1 ADDR | Read/Write | 0x00000000 |
| 0x0718 | Host DMA Channel 1 Control Register | UHDMA1 CONTROL | Read/Write | 0x00000000 |
| 0x071C | Host DMA Channel 1 Status Register | UHDMA1 STATUS | Read/Write | 0x00000000 |
| 0x0720 | Host DMA Channel 2 Next Descriptor Address Register | UHDMA2 NEXTDESC | Read/Write | 0x00000000 |
| 0x0724 | Host DMA Channel 2 HSB Address Register | UHDMA2 ADDR | Read/Write | 0x00000000 |
| 0x0728 | Host DMA Channel 2 Control Register | UHDMA2 CONTROL | Read/Write | 0x00000000 |
| 0x072C | Host DMA Channel 2 Status Register | UHDMA2 STATUS | Read/Write | 0x00000000 |
| 0x0730 | Host DMA Channel 3 Next Descriptor Address Register | UHDMA3 NEXTDESC | Read/Write | 0x00000000 |
| 0x0734 | Host DMA Channel 3 HSB Address Register | UHDMA3 ADDR | Read/Write | 0x00000000 |
| 0x0738 | Host DMA Channel 3 Control Register | UHDMA3 CONTROL | Read/Write | 0x00000000 |
| 0x073C | Host DMA Channel 3 Status Register | UHDMA3 STATUS | Read/Write | 0x00000000 |
| 0x0740 | Host DMA Channel 4 Next Descriptor Address Register | UHDMA4 NEXTDESC | Read/Write | 0x00000000 |
| 0x0744 | Host DMA Channel 4 HSB Address Register | UHDMA4 ADDR | Read/Write | 0x00000000 |
| 0x0748 | Host DMA Channel 4 Control Register | UHDMA4 CONTROL | Read/Write | 0x00000000 |
| 0x074C | Host DMA Channel 4 Status Register | UHDMA4 STATUS | Read/Write | 0x00000000 |
| 0x0750 | Host DMA Channel 5 Next Descriptor Address Register | UHDMA5 NEXTDESC | Read/Write | 0x00000000 |
| 0x0754 | Host DMA Channel 5 HSB Address Register | UHDMA5 ADDR | Read/Write | 0x00000000 |
| 0x0758 | Host DMA Channel 5 Control Register | UHDMA5 CONTROL | Read/Write | 0x00000000 |
| 0x075C | Host DMA Channel 5 Status Register | UHDMA5 STATUS | Read/Write | 0x00000000 |
| 0x0760 | Host DMA Channel 6 Next Descriptor Address Register | UHDMA6 NEXTDESC | Read/Write | 0x00000000 |
| 0x0764 | Host DMA Channel 6 HSB Address Register | UHDMA6 ADDR | Read/Write | 0x00000000 |
| 0x0768 | Host DMA Channel 6 Control Register | UHDMA6 CONTROL | Read/Write | 0x00000000 |

Table 22-4. USBB Register Memory Map

| Offset | Register | Name | Access | Reset Value |
|--------|--|---------------|------------|-------------|
| 0x076C | Host DMA Channel 6 Status Register | UHDMA6 STATUS | Read/Write | 0x00000000 |
| 0x0800 | General Control Register | USBCON | Read/Write | 0x03004000 |
| 0x0804 | General Status Register | USBSTA | Read-Only | 0x00000400 |
| 0x0808 | General Status Clear Register | USBSTACLR | Write-Only | 0x00000000 |
| 0x080C | General Status Set Register | USBSTASET | Write-Only | 0x00000000 |
| 0x0818 | IP Version Register | UVERS | Read-Only | _(1) |
| 0x081C | IP Features Register | UFEATURES | Read-Only | _(1) |
| 0x0820 | IP PB Address Size Register | UADDRSIZE | Read-Only | _(1) |
| 0x0824 | IP Name Register 1 | UNAME1 | Read-Only | _(1) |
| 0x0828 | IP Name Register 2 | UNAME2 | Read-Only | _(1) |
| 0x082C | USB Finite State Machine Status Register | USBFSM | Read-Only | 0x00000009 |

Table 22-5. USB HSB Memory Map

| Offset | Register | Name | Access | Reset Value |
|-------------------|------------------------------------|---------------|------------|-------------|
| 0x00000 - 0x0FFFC | Pipe/Endpoint 0 FIFO Data Register | USB FIFO0DATA | Read/Write | Undefined |
| 0x10000 - 0x1FFFC | Pipe/Endpoint 1 FIFO Data Register | USB FIFO1DATA | Read/Write | Undefined |
| 0x20000 - 0x2FFFC | Pipe/Endpoint 2 FIFO Data Register | USB FIFO2DATA | Read/Write | Undefined |
| 0x30000 - 0x3FFFC | Pipe/Endpoint 3 FIFO Data Register | USB FIFO3DATA | Read/Write | Undefined |
| 0x40000 - 0x4FFFC | Pipe/Endpoint 4 FIFO Data Register | USB FIFO4DATA | Read/Write | Undefined |
| 0x50000 - 0x5FFFC | Pipe/Endpoint 5 FIFO Data Register | USB FIFO5DATA | Read/Write | Undefined |
| 0x60000 - 0x6FFFC | Pipe/Endpoint 6 FIFO Data Register | USB FIFO6DATA | Read/Write | Undefined |

Note: 1. The reset values are device specific. Please refer to the Module Configuration section at the end of this chapter.

22.8.1 USB General Registers

22.8.1.1 General Control Register

Name: USBCON
Access Type: Read/Write
Offset: 0x0800
Reset Value: 0x03004000

| | | | | | | | |
|------|--------|---------|---------|--------|----|----------|---------|
| 31 | 30 | 29 | 28 | 27 | 26 | 25 | 24 |
| - | - | - | - | - | - | UIMOD | UIDE |
| 23 | 22 | 21 | 20 | 19 | 18 | 17 | 16 |
| - | UNLOCK | TIMPAGE | | - | - | TIMVALUE | |
| 15 | 14 | 13 | 12 | 11 | 10 | 9 | 8 |
| USBE | FRZCLK | VBUSPO | OTGPADE | | | | VBUSHWC |
| 7 | 6 | 5 | 4 | 3 | 2 | 1 | 0 |
| STOE | | ROLEEXE | BCERRE | VBERRE | | VBUSTE | IDTE |

- **UIMOD: USB Mode**

This bit has no effect when UIDE is one (USB_ID input pin activated).

0: The module is in USB host mode.

1: The module is in USB device mode.

This bit can be written even if USBE is zero or FRZCLK is one. Disabling the USB (by writing a zero to the USBE bit) does not reset this bit.

- **UIDE: USB_ID Pin Enable**

0: The USB mode (device/host) is selected from the UIMOD bit.

1: The USB mode (device/host) is selected from the USB_ID input pin.

This bit can be written even if USBE is zero or FRZCLK is one. Disabling the USB (by writing a zero to the USBE bit) does not reset this bit.

- **UNLOCK: Timer Access Unlock**

1: The TIMPAGE and TIMVALUE fields are unlocked.

0: The TIMPAGE and TIMVALUE fields are locked.

The TIMPAGE and TIMVALUE fields can always be read, whatever the value of UNLOCK.

- **TIMPAGE: Timer Page**

This field contains the page value to access a special timer register.

- **TIMVALUE: Timer Value**

This field selects the timer value that is written to the special time register selected by TIMPAGE. See [Section 22.7.1.8](#) for details.

- **USBE: USB Enable**

Writing a zero to this bit will reset the USB, disable the USB transceiver and, disable the USB clock inputs. Unless explicitly stated, all registers then will become read-only and will be reset.

1: The USB is enabled.

0: The USB is disabled.

This bit can be written even if FRZCLK is one.

- **FRZCLK: Freeze USB Clock**

1: The clock input are disabled (the resume detection is still active). This reduces power consumption. Unless explicitly stated, all registers then become read-only.

0: The clock inputs are enabled.

This bit can be written even if USBE is zero. Disabling the USBB (by writing a zero to the USBE bit) does not reset this bit, but this freezes the clock inputs whatever its value.

- **VBUSPO: VBus Polarity**

1: The USB_VBOF output signal is inverted (active low).

0: The USB_VBOF output signal is in its default mode (active high).

To be generic. May be useful to control an external VBus power module.

This bit can be written even if USBE is zero or FRZCLK is one. Disabling the USBB (by writing a zero to the USBE bit) does not reset this bit.

- **OTGPADE: OTG Pad Enable**

1: The OTG pad is enabled.

0: The OTG pad is disabled.

This bit can be written even if USBE is zero or FRZCLK is one. Disabling the USBB (by writing a zero to the USBE bit) does not reset this bit.

- **VBUSHWC: VBus Hardware Control**

1: The hardware control over the USB_VBOF output pin is disabled.

0: The hardware control over the USB_VBOF output pin is enabled. The USBB resets the USB_VBOF output pin when a VBUS problem occurs.

- **STOE: Suspend Time-Out Interrupt Enable**

1: The Suspend Time-Out Interrupt (STOI) is enabled.

0: The Suspend Time-Out Interrupt (STOI) is disabled.

- **ROLEEXE: Role Exchange Interrupt Enable**

1: The Role Exchange Interrupt (ROLEEXI) is enabled.

0: The Role Exchange Interrupt (ROLEEXI) is disabled.

- **BCERRE: B-Connection Error Interrupt Enable**

1: The B-Connection Error Interrupt (BCERRI) is enabled.

0: The B-Connection Error Interrupt (BCERRI) is disabled.

- **VBERRE: VBus Error Interrupt Enable**

1: The VBus Error Interrupt (VBERRI) is enabled.

0: The VBus Error Interrupt (VBERRI) is disabled.

- **VBUSTE: VBus Transition Interrupt Enable**

1: The VBus Transition Interrupt (VBUSTI) is enabled.

0: The VBus Transition Interrupt (VBUSTI) is disabled.

- **IDTE: ID Transition Interrupt Enable**

1: The ID Transition interrupt (IDTI) is enabled.

0: The ID Transition interrupt (IDTI) is disabled.

22.8.1.2 General Status Register

Register Name: USBSTA
Access Type: Read-Only
Offset: 0x0804
Reset Value: 0x00000400

| | | | | | | | |
|------|----|---------|--------|--------|----|--------|------|
| 31 | 30 | 29 | 28 | 27 | 26 | 25 | 24 |
| - | - | - | - | - | - | - | - |
| 23 | 22 | 21 | 20 | 19 | 18 | 17 | 16 |
| - | - | - | - | - | - | - | - |
| 15 | 14 | 13 | 12 | 11 | 10 | 9 | 8 |
| - | - | SPEED | | VBUS | ID | VBUSRQ | - |
| 7 | 6 | 5 | 4 | 3 | 2 | 1 | 0 |
| STOI | | ROLEEXI | BCERRI | VBERRI | | VBUSTI | IDTI |

- **SPEED: Speed Status**

This field is set according to the controller speed mode..

| SPEED | | Speed Status |
|-------|---|-----------------|
| 0 | 0 | Full-Speed mode |
| 1 | 0 | Low-Speed mode |
| X | 1 | Reserved |

- **VBUS: VBus Level**

This bit is set when the VBus line level is high.

This bit is cleared when the VBus line level is low.

This bit can be used in either device or host mode to monitor the USB bus connection state of the application.

- **ID: USB_ID Pin State**

This bit is cleared when the USB_ID level is low, even if USBE is zero.

This bit is set when the USB_ID level is high, event if USBE is zero.

- **VBUSRQ: VBus Request**

This bit is set when the USBSTASET.VBUSRQS bit is written to one.

This bit is cleared when the USBSTACL.R.VBUSRQC bit is written to one or when a VBus error occurs and VBUSHWC is zero.

1: The USB_VBOF output pin is driven high to enable the VBUS power supply generation.

0: The USB_VBOF output pin is driven low to disable the VBUS power supply generation.

This bit shall only be used in host mode.

- **STOI: Suspend Time-Out Interrupt**

This bit is set when a time-out error (more than 200ms) has been detected after a suspend. This triggers a USB interrupt if STOE is one.

This bit is cleared when the UBSTACL.R.STOIC bit is written to one.

This bit shall only be used in host mode.



- **ROLEEXI: Role Exchange Interrupt**

This bit is set when the USBB has successfully switched its mode because of a negotiation (host to device or device to host).
This triggers a USB interrupt if ROLEEXE is one.
This bit is cleared when the UBSTACLR.ROLEEXIC bit is written to one.
- **BCERRI: B-Connection Error Interrupt**

This bit is set when an error occurs during the B-connection. This triggers a USB interrupt if BCERRE is one.
This bit is cleared when the UBSTACLR.BCERRIC bit is written to one.
This bit shall only be used in host mode.
- **VBERRI: VBus Error Interrupt**

This bit is set when a VBus drop has been detected. This triggers a USB interrupt if VBERRE is one.
This bit is cleared when the UBSTACLR.VBERRIC bit is written to one.
This bit shall only be used in host mode.
If a VBus problem occurs, then the VBERRI interrupt is generated even if the USBB does not go to an error state because of VBUSHWC is one.
- **VBUSTI: VBus Transition Interrupt**

This bit is set when a transition (high to low, low to high) has been detected on the USB_VBUS pad. This triggers an USB interrupt if VBUSTE is one.
This bit is cleared when the UBSTACLR.VBUSTIC bit is written to one.
This interrupt is generated even if the clock is frozen by the FRZCLK bit.
- **IDTI: ID Transition Interrupt**

This bit is set when a transition (high to low, low to high) has been detected on the USB_ID input pin. This triggers an USB interrupt if IDTE is one.
This bit is cleared when the UBSTACLR.IDTIC bit is written to one.
This interrupt is generated even if the clock is frozen by the FRZCLK bit or pad is disable by USBCON.OTGPADE or the USBB module is disabled by USBCON.USBE.

22.8.1.3 General Status Clear Register

Register Name: USBSTACL

Access Type: Write-Only

Offset: 0x0808

Read Value: 0x00000000

| | | | | | | | |
|-------|----|----------|---------|---------|----|---------|-------|
| 31 | 30 | 29 | 28 | 27 | 26 | 25 | 24 |
| - | - | - | - | - | - | - | - |
| 23 | 22 | 21 | 20 | 19 | 18 | 17 | 16 |
| - | - | - | - | - | - | - | - |
| 15 | 14 | 13 | 12 | 11 | 10 | 9 | 8 |
| - | - | - | - | - | - | VBUSRQC | - |
| 7 | 6 | 5 | 4 | 3 | 2 | 1 | 0 |
| STOIC | | ROLEEXIC | BCERRIC | VBERRIC | | VBUSTIC | IDTIC |

Writing a one to a bit in this register will clear the corresponding bit in UBSTA.

Writing a zero to a bit in this register has no effect.

This bit always reads as zero.

22.8.1.4 General Status Set Register

Register Name: USBSTASET
Access Type: Write-Only
Offset: 0x080C
Read Value: 0x00000000

| | | | | | | | |
|-------|----|----------|---------|---------|----|---------|-------|
| 31 | 30 | 29 | 28 | 27 | 26 | 25 | 24 |
| - | - | - | - | - | - | - | - |
| 23 | 22 | 21 | 20 | 19 | 18 | 17 | 16 |
| - | - | - | - | - | - | - | - |
| 15 | 14 | 13 | 12 | 11 | 10 | 9 | 8 |
| - | - | - | - | - | - | VBUSRQS | - |
| 7 | 6 | 5 | 4 | 3 | 2 | 1 | 0 |
| STOIS | | ROLEEXIS | BCERRIS | VBERRIS | | VBUSTIS | IDTIS |

Writing a one to a bit in this register will set the corresponding bit in UBSTA, what may be useful for test or debug purposes.
 Writing a zero to a bit in this register has no effect.
 This bit always reads as zero.

22.8.1.5 Version Register

Register Name: UVERS

Access Type: Read-Only

Offset: 0x0818

Read Value: -

| | | | | | | | |
|--------------|----|----|----|---------------|----|----|----|
| 31 | 30 | 29 | 28 | 27 | 26 | 25 | 24 |
| - | - | - | - | - | - | - | - |
| 23 | 22 | 21 | 20 | 19 | 18 | 17 | 16 |
| - | - | - | - | VARIANT | | | |
| 15 | 14 | 13 | 12 | 11 | 10 | 9 | 8 |
| - | - | - | - | VERSION[11:8] | | | |
| 7 | 6 | 5 | 4 | 3 | 2 | 1 | 0 |
| VERSION[7:0] | | | | | | | |

- **VARIANT: Variant Number**
Reserved. No functionality associated.
- **VERSION: Version Number**
Version number of the module. No functionality associated.

22.8.1.6 Features Register

Register Name: UFEATURES

Access Type: Read-Only

Offset: 0x081C

Read Value: -

| | | | | | | | |
|--------------------|---------------|----|----|------------------|----|----|----|
| 31 | 30 | 29 | 28 | 27 | 26 | 25 | 24 |
| - | - | - | - | - | - | - | - |
| 23 | 22 | 21 | 20 | 19 | 18 | 17 | 16 |
| - | - | - | - | - | - | - | - |
| 15 | 14 | 13 | 12 | 11 | 10 | 9 | 8 |
| BYTEWRITE DPRAM | FIFOMAXSIZE | | | DMAFIFOWORDDEPTH | | | |
| 7 | 6 | 5 | 4 | 3 | 2 | 1 | 0 |
| DMABUFFE RSIZE | DMACHANNELNBR | | | EPTNBRMAX | | | |

- **BYTEWRITEDPRAM: DPRAM Byte-Write Capability**

1: The DPRAM is natively byte-write capable.

0: The DPRAM byte write lanes have shadow logic implemented in the USBB IP interface.

- **FIFOMAXSIZE: Maximal FIFO Size**

This field indicates the maximal FIFO size, i.e., the DPRAM size:

| FIFOMAXSIZE | | | Maximal FIFO Size |
|-------------|---|---|-------------------|
| 0 | 0 | 0 | < 256 bytes |
| 0 | 0 | 1 | < 512 bytes |
| 0 | 1 | 0 | < 1024 bytes |
| 0 | 1 | 1 | < 2048 bytes |
| 1 | 0 | 0 | < 4096 bytes |
| 1 | 0 | 1 | < 8192 bytes |
| 1 | 1 | 0 | < 16384 bytes |
| 1 | 1 | 1 | >= 16384 bytes |

- **DMAFIFOWORDDEPTH: DMA FIFO Depth in Words**

This field indicates the DMA FIFO depth controller in words:

| DMAFIFOWORDDEPTH | | | | DMA FIFO Depth in Words |
|------------------|---|---|---|-------------------------|
| 0 | 0 | 0 | 0 | 16 |
| 0 | 0 | 0 | 1 | 1 |
| 0 | 0 | 1 | 0 | 2 |
| | | | | ... |
| 1 | 1 | 1 | 1 | 15 |

- **DMABUFFERSIZE: DMA Buffer Size**

1: The DMA buffer size is 24 bits.

0: The DMA buffer size is 16 bits.

- **DMACHANNELNBR: Number of DMA Channels**

This field indicates the number of hardware-implemented DMA channels:

| DMACHANNELNBR | | | Number of DMA Channels |
|---------------|---|---|------------------------|
| 0 | 0 | 0 | Reserved |
| 0 | 0 | 1 | 1 |
| 0 | 1 | 0 | 2 |
| | | | ... |
| 1 | 1 | 1 | 7 |

- **EPTNBRMAX: Maximal Number of Pipes/Endpoints**

This field indicates the number of hardware-implemented pipes/endpoints:

| EPTNBRMAX | | | | Maximal Number of Pipes/Endpoints |
|-----------|---|---|---|-----------------------------------|
| 0 | 0 | 0 | 0 | 16 |
| 0 | 0 | 0 | 1 | 1 |
| 0 | 0 | 1 | 0 | 2 |
| | | | | ... |
| 1 | 1 | 1 | 1 | 15 |

22.8.1.7 Address Size Register

Register Name: UADDRSIZE

Access Type: Read-Only

Offset: 0x0820

Read Value: -

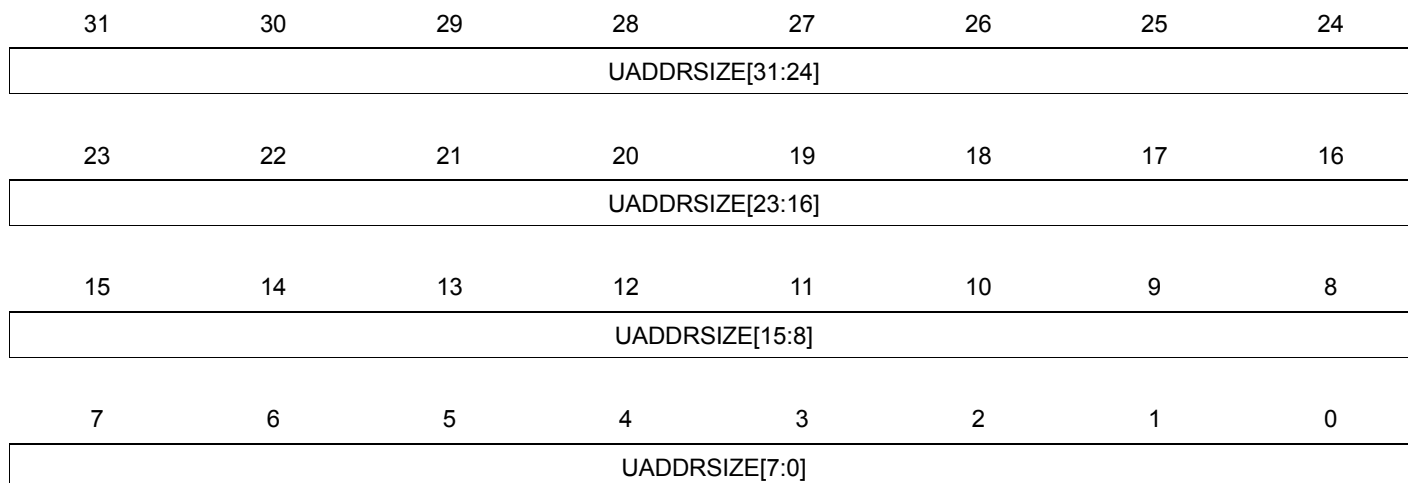

- **UADDRSIZE: IP PB Address Size**

This field indicates the size of the PB address space reserved for the USBB IP interface.

22.8.1.8 Name Register 1

Register Name: UNAME1
Access Type: Read-Only
Offset: 0x0824
Read Value: -

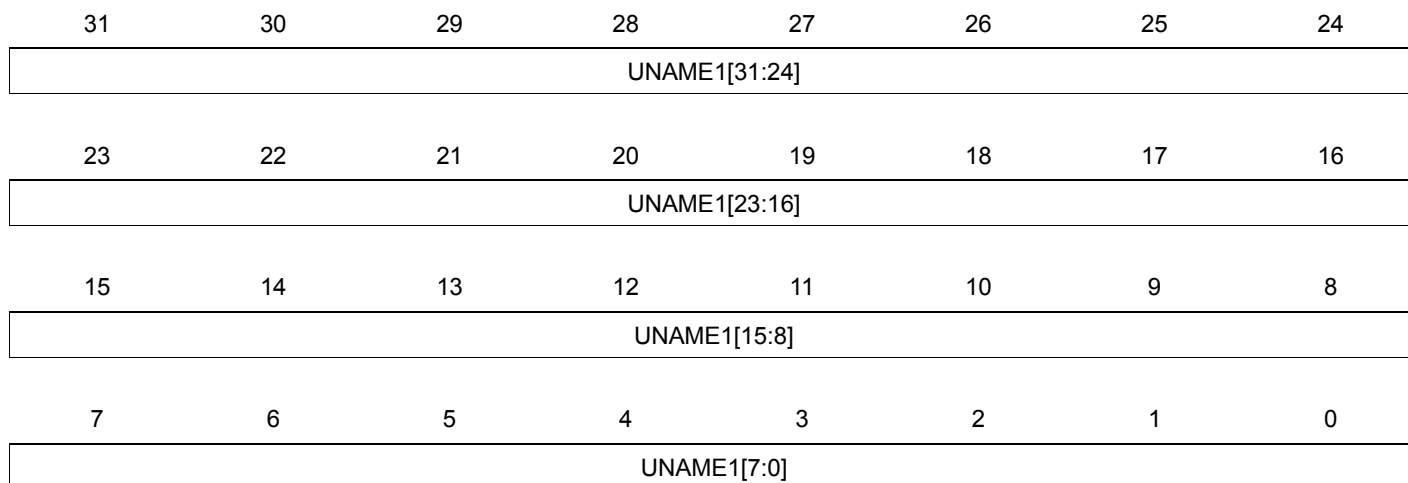

- **UNAME1: IP Name Part One**

This field indicates the first part of the ASCII-encoded name of the USBB IP.

22.8.1.9 Name Register 2

Register Name: UNAME2

Access Type: Read-Only

Offset: 0x0828

Read Value:

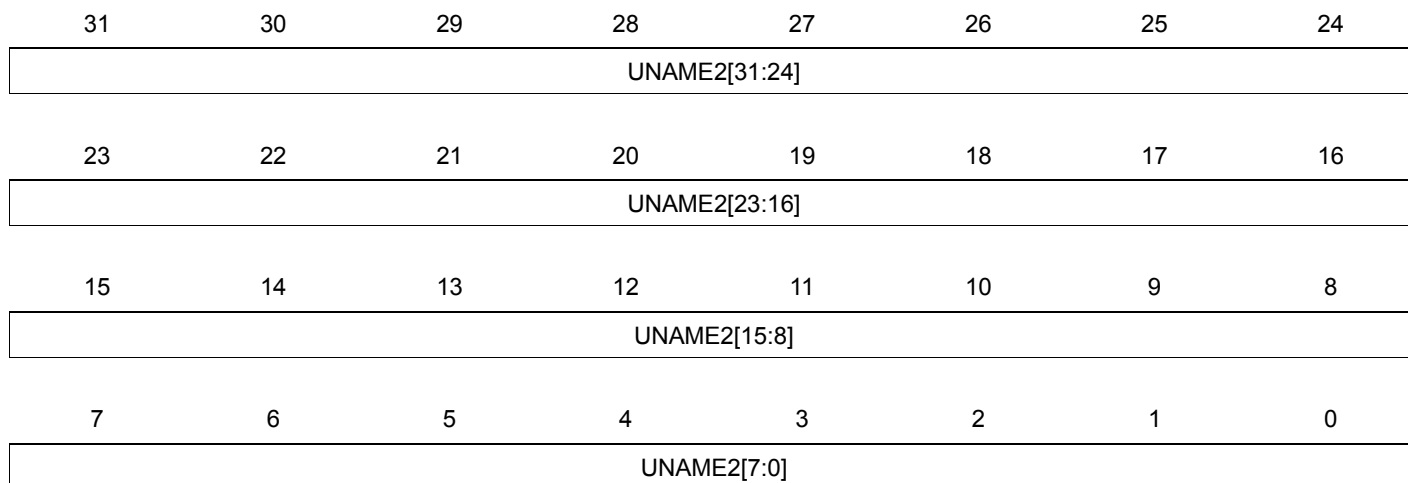

- **UNAME2: IP Name Part Two**

This field indicates the second part of the ASCII-encoded name of the USBB IP.

22.8.1.10 Finite State Machine Status Register

Register Name: USBFSM
Access Type: Read-Only
Offset: 0x082C
Read Value: 0x00000009

| | | | | | | | | |
|----|----|----|----|----------|----|----|----|--|
| 31 | 30 | 29 | 28 | 27 | 26 | 25 | 24 | |
| - | - | - | - | - | - | - | - | |
| 23 | 22 | 21 | 20 | 19 | 18 | 17 | 16 | |
| - | - | - | - | - | - | - | - | |
| 15 | 14 | 13 | 12 | 11 | 10 | 9 | 8 | |
| - | - | - | - | - | - | - | - | |
| 7 | 6 | 5 | 4 | 3 | 2 | 1 | 0 | |
| - | - | - | - | DRDSTATE | | | | |

• DRDSTATE

This field indicates the state of the USBB.

| DRDSTATE | Description |
|----------|--|
| 0 | a_idle state: this is the start state for A-devices (when the ID pin is 0) |
| 1 | a_wait_vrise: In this state, the A-device waits for the voltage on VBus to rise above the A-device VBus Valid threshold (4.4 V). |
| 2 | a_wait_bcon: In this state, the A-device waits for the B-device to signal a connection. |
| 3 | a_host: In this state, the A-device that operates in Host mode is operational. |
| 4 | a_suspend: The A-device operating as a host is in the suspend mode. |
| 5 | a_peripheral: The A-device operates as a peripheral. |
| 6 | a_wait_vfall: In this state, the A-device waits for the voltage on VBus to drop below the A-device Session Valid threshold (1.4 V). |
| 7 | a_vbus_err: In this state, the A-device waits for recovery of the over-current condition that caused it to enter this state. |
| 8 | a_wait_discharge: In this state, the A-device waits for the data usb line to discharge (100 us). |
| 9 | b_idle: this is the start state for B-device (when the ID pin is 1). |
| 10 | b_peripheral: In this state, the B-device acts as the peripheral. |
| 11 | b_wait_begin_hnp: In this state, the B-device is in suspend mode and waits until 3 ms before initiating the HNP protocol if requested. |
| 12 | b_wait_discharge: In this state, the B-device waits for the data usb line to discharge (100 us) before becoming Host. |

| DRDSTATE | Description |
|----------|---|
| 13 | b_wait_acon: In this state, the B-device waits for the A-device to signal a connect before becoming B-Host. |
| 14 | b_host: In this state, the B-device acts as the Host. |
| 15 | b_srp_init: In this state, the B-device attempts to start a session using the SRP protocol. |

22.8.2 USB Device Registers

22.8.2.1 Device General Control Register

Register Name: UDCON
Access Type: Read/Write
Offset: 0x0000
Reset Value: 0x00000100

| | | | | | | | |
|-------|------|----|----|----|----|--------|--------|
| 31 | 30 | 29 | 28 | 27 | 26 | 25 | 24 |
| - | - | - | - | - | - | - | - |
| 23 | 22 | 21 | 20 | 19 | 18 | 17 | 16 |
| - | - | - | - | - | - | - | - |
| 15 | 14 | 13 | 12 | 11 | 10 | 9 | 8 |
| - | - | - | LS | - | - | RMWKUP | DETACH |
| 7 | 6 | 5 | 4 | 3 | 2 | 1 | 0 |
| ADDEN | UADD | | | | | | |

- LS: Low-Speed Mode Force**
 1: The low-speed mode is active.
 0: The full-speed mode is active.
 This bit can be written even if USBE is zero or FRZCLK is one. Disabling the USBB (by writing a zero to the USBE bit) does not reset this bit.
- RMWKUP: Remote Wake-Up**
 Writing a one to this bit will send an upstream resume to the host for a remote wake-up.
 Writing a zero to this bit has no effect.
 This bit is cleared when the USBB receive a USB reset or once the upstream resume has been sent.
- DETACH: Detach**
 Writing a one to this bit will physically detach the device (disconnect internal pull-up resistor from D+ and D-).
 Writing a zero to this bit will reconnect the device.
- ADDEN: Address Enable**
 Writing a one to this bit will activate the UADD field (USB address).
 Writing a zero to this bit has no effect.
 This bit is cleared when a USB reset is received.
- UADD: USB Address**
 This field contains the device address.
 This field is cleared when a USB reset is received.

22.8.2.2 Device Global Interrupt Register

Register Name: UDINT
Access Type: Read-Only
Offset: 0x0004
Reset Value: 0x00000000

| | | | | | | | |
|--------|---------|---------|---------|---------|---------|---------|--------|
| 31 | 30 | 29 | 28 | 27 | 26 | 25 | 24 |
| - | DMA6INT | DMA5INT | DMA4INT | DMA3INT | DMA2INT | DMA1INT | - |
| 23 | 22 | 21 | 20 | 19 | 18 | 17 | 16 |
| - | - | - | - | - | EP6INT | EP5INT | EP4INT |
| 15 | 14 | 13 | 12 | 11 | 10 | 9 | 8 |
| EP3INT | EP2INT | EP1INT | EP0INT | - | - | - | - |
| 7 | 6 | 5 | 4 | 3 | 2 | 1 | 0 |
| - | UPRSM | EORSM | WAKEUP | EORST | SOF | - | SUSP |

- DMA n INT: DMA Channel n Interrupt**
 This bit is set when an interrupt is triggered by the DMA channel n . This triggers a USB interrupt if DMA n INTE is one.
 This bit is cleared when the UDDMANSTATUS interrupt source is cleared.
- EP n INT: Endpoint n Interrupt**
 This bit is set when an interrupt is triggered by the endpoint n (UESTAN, UECON n). This triggers a USB interrupt if EP n INTE is one.
 This bit is cleared when the interrupt source is serviced.
- UPRSM: Upstream Resume Interrupt**
 This bit is set when the USBB sends a resume signal called “Upstream Resume”. This triggers a USB interrupt if UPRSME is one.
 This bit is cleared when the UDINTCLR.UPRSMC bit is written to one to acknowledge the interrupt (USB clock inputs must be enabled before).
- EORSM: End of Resume Interrupt**
 This bit is set when the USBB detects a valid “End of Resume” signal initiated by the host. This triggers a USB interrupt if EORSME is one.
 This bit is cleared when the UDINTCLR.EORSMC bit is written to one to acknowledge the interrupt.
- WAKEUP: Wake-Up Interrupt**
 This bit is set when the USBB is reactivated by a filtered non-idle signal from the lines (not by an upstream resume). This triggers an interrupt if WAKEUPE is one.
 This bit is cleared when the UDINTCLR.WAKEUPC bit is written to one to acknowledge the interrupt (USB clock inputs must be enabled before).
 This bit is cleared when the Suspend (SUSP) interrupt bit is set.
 This interrupt is generated even if the clock is frozen by the FRZCLK bit.
- EORST: End of Reset Interrupt**
 This bit is set when a USB “End of Reset” has been detected. This triggers a USB interrupt if EORSTE is one.
 This bit is cleared when the UDINTCLR.EORSTC bit is written to one to acknowledge the interrupt.

- **SOF: Start of Frame Interrupt**

This bit is set when a USB “Start of Frame” PID (SOF) has been detected (every 1 ms). This triggers a USB interrupt if SOFE is one. The FNUM field is updated.

This bit is cleared when the UDINTCLR.SOFC bit is written to one to acknowledge the interrupt.

- **SUSP: Suspend Interrupt**

This bit is set when a USB “Suspend” idle bus state has been detected for 3 frame periods (J state for 3 ms). This triggers a USB interrupt if SUSPE is one.

This bit is cleared when the UDINTCLR.SUSPC bit is written to one to acknowledge the interrupt.

This bit is cleared when the Wake-Up (WAKEUP) interrupt bit is set.

22.8.2.3 Device Global Interrupt Clear Register

Register Name: UDINTCLR

Access Type: Write-Only

Offset: 0x0008

Read Value: 0x00000000

| | | | | | | | |
|----|--------|--------|---------|--------|------|----|-------|
| 31 | 30 | 29 | 28 | 27 | 26 | 25 | 24 |
| - | - | - | - | - | - | - | - |
| 23 | 22 | 21 | 20 | 19 | 18 | 17 | 16 |
| - | - | - | - | - | - | - | - |
| 15 | 14 | 13 | 12 | 11 | 10 | 9 | 8 |
| - | - | - | - | - | - | - | - |
| 7 | 6 | 5 | 4 | 3 | 2 | 1 | 0 |
| - | UPRSMC | EORSMC | WAKEUPC | EORSTC | SOFC | - | SUSPC |

Writing a one to a bit in this register will clear the corresponding bit in UDINT.

Writing a zero to a bit in this register has no effect.

This bit always reads as zero.

22.8.2.4 Device Global Interrupt Set Register

Register Name: UDINTSET
Access Type: Write-Only
Offset: 0x000C
Read Value: 0x00000000

| | | | | | | | |
|----|----------|----------|----------|----------|----------|----------|-------|
| 31 | 30 | 29 | 28 | 27 | 26 | 25 | 24 |
| - | DMA6INTS | DMA5INTS | DMA4INTS | DMA3INTS | DMA2INTS | DMA1INTS | - |
| 23 | 22 | 21 | 20 | 19 | 18 | 17 | 16 |
| - | - | - | - | - | - | - | - |
| 15 | 14 | 13 | 12 | 11 | 10 | 9 | 8 |
| - | - | - | - | - | - | - | - |
| 7 | 6 | 5 | 4 | 3 | 2 | 1 | 0 |
| - | UPRSMS | EORSMS | WAKEUPS | EORSTS | SOFS | - | SUSPS |

Writing a one to a bit in this register will set the corresponding bit in UDINT, what may be useful for test or debug purposes.
 Writing a zero to a bit in this register has no effect.
 This bit always reads as zero.

22.8.2.5 Device Global Interrupt Enable Register

Register Name: UDINTE
Access Type: Read-Only
Offset: 0x0010
Reset Value: 0x00000000

| | | | | | | | |
|---------|----------|----------|----------|----------|----------|----------|---------|
| 31 | 30 | 29 | 28 | 27 | 26 | 25 | 24 |
| - | DMA6INTE | DMA5INTE | DMA4INTE | DMA3INTE | DMA2INTE | DMA1INTE | - |
| 23 | 22 | 21 | 20 | 19 | 18 | 17 | 16 |
| - | - | - | - | - | EP6INTE | EP5INTE | EP4INTE |
| 15 | 14 | 13 | 12 | 11 | 10 | 9 | 8 |
| EP3INTE | EP2INTE | EP1INTE | EP0INTE | - | - | - | - |
| 7 | 6 | 5 | 4 | 3 | 2 | 1 | 0 |
| - | UPRSME | EORSME | WAKEUPE | EORSTE | SOFE | - | SUSPE |

1: The corresponding interrupt is enabled.

0: The corresponding interrupt is disabled.

A bit in this register is set when the corresponding bit in UDINTESET is written to one.

A bit in this register is cleared when the corresponding bit in UDINTECLR is written to one.

22.8.2.6 Device Global Interrupt Enable Clear Register

Register Name: UDINTECLR

Access Type: Write-Only

Offset: 0x0014

Read Value: 0x00000000

| | | | | | | | |
|----------|-----------|-----------|-----------|-----------|-----------|-----------|----------|
| 31 | 30 | 29 | 28 | 27 | 26 | 25 | 24 |
| - | DMA6INTEC | DMA5INTEC | DMA4INTEC | DMA3INTEC | DMA2INTEC | DMA1INTEC | - |
| 23 | 22 | 21 | 20 | 19 | 18 | 17 | 16 |
| - | - | - | - | - | EP6INTEC | EP5INTEC | EP4INTEC |
| 15 | 14 | 13 | 12 | 11 | 10 | 9 | 8 |
| EP3INTEC | EP2INTEC | EP1INTEC | EP0INTEC | - | - | - | - |
| 7 | 6 | 5 | 4 | 3 | 2 | 1 | 0 |
| - | UPRSMEC | EORSMEC | WAKEUPEC | EORSTEC | SOFEC | - | SUSPEC |

Writing a one to a bit in this register will clear the corresponding bit in UDINTE.

Writing a zero to a bit in this register has no effect.

This bit always reads as zero.

22.8.2.7 Device Global Interrupt Enable Set Register

Register Name: UDINTESET

Access Type: Write-Only

Offset: 0x0018

Read Value: 0x00000000

| | | | | | | | |
|----------|-----------|-----------|-----------|-----------|-----------|-----------|----------|
| 31 | 30 | 29 | 28 | 27 | 26 | 25 | 24 |
| - | DMA6INTES | DMA5INTES | DMA4INTES | DMA3INTES | DMA2INTES | DMA1INTES | - |
| 23 | 22 | 21 | 20 | 19 | 18 | 17 | 16 |
| - | - | - | - | - | EP6INTES | EP5INTES | EP4INTES |
| 15 | 14 | 13 | 12 | 11 | 10 | 9 | 8 |
| EP3INTES | EP2INTES | EP1INTES | EP0INTES | - | - | - | - |
| 7 | 6 | 5 | 4 | 3 | 2 | 1 | 0 |
| - | UPRSMES | EORSMES | WAKEUPES | EORSTES | SOFES | - | SUSPES |

Writing a one to a bit in this register will set the corresponding bit in UDINTE.

Writing a zero to a bit in this register has no effect.

This bit always reads as zero.

22.8.2.8 Endpoint Enable/Reset Register

Register Name: UERST
Access Type: Read/Write
Offset: 0x001C
Reset Value: 0x00000000

| | | | | | | | |
|----|--------|--------|--------|--------|--------|--------|--------|
| 31 | 30 | 29 | 28 | 27 | 26 | 25 | 24 |
| - | - | - | - | - | - | - | - |
| 23 | 22 | 21 | 20 | 19 | 18 | 17 | 16 |
| - | EPRST6 | EPRST5 | EPRST4 | EPRST3 | EPRST2 | EPRST1 | EPRST0 |
| 15 | 14 | 13 | 12 | 11 | 10 | 9 | 8 |
| - | - | - | - | - | - | - | - |
| 7 | 6 | 5 | 4 | 3 | 2 | 1 | 0 |
| - | EPEN6 | EPEN5 | EPEN4 | EPEN3 | EPEN2 | EPEN1 | EPEN0 |

- **EPRSTn: Endpoint n Reset**

Writing a one to this bit will reset the endpoint n FIFO prior to any other operation, upon hardware reset or when a USB bus reset has been received. This resets the endpoint n registers (UECFGn, UESTAn, UECONn) but not the endpoint configuration (ALLOC, EPBK, EPSIZE, EPDIR, EPTYPE).

All the endpoint mechanism (FIFO counter, reception, transmission, etc.) is reset apart from the Data Toggle Sequence field (DTSEQ) which can be cleared by setting the RSTDT bit (by writing a one to the RSTDTS bit).

The endpoint configuration remains active and the endpoint is still enabled.

Writing a zero to this bit will complete the reset operation and start using the FIFO.

This bit is cleared upon receiving a USB reset.

- **EPENn: Endpoint n Enable**

1: The endpoint n is enabled.

0: The endpoint n is disabled, what forces the endpoint n state to inactive (no answer to USB requests) and resets the endpoint n registers (UECFGn, UESTAn, UECONn) but not the endpoint configuration (ALLOC, EPBK, EPSIZE, EPDIR, EPTYPE).

22.8.2.9 Device Frame Number Register

Register Name: UDFNUM
Access Type: Read-Only
Offset: 0x0020
Reset Value: 0x00000000

| | | | | | | | |
|-----------|----|------------|----|----|----|----|----|
| 31 | 30 | 29 | 28 | 27 | 26 | 25 | 24 |
| - | - | - | - | - | - | - | - |
| 23 | 22 | 21 | 20 | 19 | 18 | 17 | 16 |
| - | - | - | - | - | - | - | - |
| 15 | 14 | 13 | 12 | 11 | 10 | 9 | 8 |
| FNCERR | - | FNUM[10:5] | | | | | |
| 7 | 6 | 5 | 4 | 3 | 2 | 1 | 0 |
| FNUM[4:0] | | | | | - | - | - |

- **FNCERR: Frame Number CRC Error**

This bit is set when a corrupted frame number is received. This bit and the SOF interrupt bit are updated at the same time. This bit is cleared upon receiving a USB reset.

- **FNUM: Frame Number**

This field contains the 11-bit frame number information. It is provided in the last received SOF packet. This field is cleared upon receiving a USB reset. FNUM is updated even if a corrupted SOF is received.

22.8.2.10 Endpoint n Configuration Register

Register Name: UECEFGn, n in [0..6]

Access Type: Read/Write

Offset: 0x0100 + (n * 0x04)

Reset Value: 0x00000000

| | | | | | | | |
|----|--------|----|--------|------|----|--------|-------|
| 31 | 30 | 29 | 28 | 27 | 26 | 25 | 24 |
| - | - | - | - | - | - | - | - |
| 23 | 22 | 21 | 20 | 19 | 18 | 17 | 16 |
| - | - | - | - | - | - | - | - |
| 15 | 14 | 13 | 12 | 11 | 10 | 9 | 8 |
| - | - | - | EPTYPE | | - | AUTOSW | EPDIR |
| 7 | 6 | 5 | 4 | 3 | 2 | 1 | 0 |
| - | EPSIZE | | | EPBK | | ALLOC | - |

- **EPTYPE: Endpoint Type**

This field shall be written to select the endpoint type:

| EPTYPE | | Endpoint Type |
|--------|---|---------------|
| 0 | 0 | Control |
| 0 | 1 | Isochronous |
| 1 | 0 | Bulk |
| 1 | 1 | Interrupt |

This field is cleared upon receiving a USB reset.

- **AUTOSW: Automatic Switch**

This bit is cleared upon receiving a USB reset.

1: The automatic bank switching is enabled.

0: The automatic bank switching is disabled.

- **EPDIR: Endpoint Direction**

This bit is cleared upon receiving a USB reset.

1: The endpoint direction is IN (nor for control endpoints).

0: The endpoint direction is OUT.

- **EPSIZE: Endpoint Size**

This field shall be written to select the size of each endpoint bank. The maximum size of each endpoint is specified in [Table 22-1 on page 352](#).

| EPSIZE | | | Endpoint Size |
|--------|---|---|---------------|
| 0 | 0 | 0 | 8 bytes |
| 0 | 0 | 1 | 16 bytes |
| 0 | 1 | 0 | 32 bytes |
| 0 | 1 | 1 | 64 bytes |
| 1 | 0 | 0 | 128 bytes |
| 1 | 0 | 1 | 256 bytes |
| 1 | 1 | 0 | 512 bytes |

This field is cleared upon receiving a USB reset (except for the endpoint 0).

- **EPBK: Endpoint Banks**

This field shall be written to select the number of banks for the endpoint:

| EPBK | | Endpoint Banks |
|------|---|--|
| 0 | 0 | 1 (single-bank endpoint) |
| 0 | 1 | 2 (double-bank endpoint) |
| 1 | 0 | 3 (triple-bank endpoint) if supported (see Table 22-1 on page 352). |
| 1 | 1 | Reserved |

For control endpoints, a single-bank endpoint (0b00) shall be selected.

This field is cleared upon receiving a USB reset (except for the endpoint 0).

- **ALLOC: Endpoint Memory Allocate**

Writing a one to this bit will allocate the endpoint memory. The user should check the CFGOK bit to know whether the allocation of this endpoint is correct.

Writing a zero to this bit will free the endpoint memory.

This bit is cleared upon receiving a USB reset (except for the endpoint 0).

22.8.2.11 Endpoint n Status Register

Register Name: UESTAn, n in [0..6]

Access Type: Read-Only 0x0100

Offset: 0x0130 + (n * 0x04)

Reset Value: 0x00000100

| | | | | | | | |
|-----------------|---------------------|---------|--------|---------|--------------------|---------|-------|
| 31 | 30 | 29 | 28 | 27 | 26 | 25 | 24 |
| - | BYCT | | | | | | |
| 23 | 22 | 21 | 20 | 19 | 18 | 17 | 16 |
| BYCT | | | | - | CFGOK | CTRLDIR | RWALL |
| 15 | 14 | 13 | 12 | 11 | 10 | 9 | 8 |
| CURRBK | | NBUSYBK | | - | - | DTSEQ | |
| 7 | 6 | 5 | 4 | 3 | 2 | 1 | 0 |
| SHORT PACKET | STALLED/ CRCERRI | OVERFI | NAKINI | NAKOUTI | RXSTPI/ UNDERFI | RXOUTI | TXINI |

- **BYCT: Byte Count**

This field is set with the byte count of the FIFO.

For IN endpoints, incremented after each byte written by the software into the endpoint and decremented after each byte sent to the host.

For OUT endpoints, incremented after each byte received from the host and decremented after each byte read by the software from the endpoint.

This field may be updated one clock cycle after the RWALL bit changes, so the user should not poll this field as an interrupt bit.

- **CFGOK: Configuration OK Status**

This bit is updated when the ALLOC bit is written to one.

This bit is set if the endpoint n number of banks (EPBK) and size (EPSIZE) are correct compared to the maximal allowed number of banks and size for this endpoint and to the maximal FIFO size (i.e. the DPRAM size).

If this bit is cleared, the user shall rewrite correct values to the EPBK and EPSIZE fields in the UECFGn register.

- **CTRLDIR: Control Direction**

This bit is set after a SETUP packet to indicate that the following packet is an IN packet.

This bit is cleared after a SETUP packet to indicate that the following packet is an OUT packet.

Writing a zero or a one to this bit has no effect.

- **RWALL: Read/Write Allowed**

This bit is set for IN endpoints when the current bank is not full, i.e., the user can write further data into the FIFO.

This bit is set for OUT endpoints when the current bank is not empty, i.e., the user can read further data from the FIFO.

This bit is never set if STALLRQ is one or in case of error.

This bit is cleared otherwise.

This bit shall not be used for control endpoints.

- **CURRBK: Current Bank**

This bit is set for non-control endpoints, to indicate the current bank:

| CURRBK | | Current Bank |
|--------|---|---|
| 0 | 0 | Bank0 |
| 0 | 1 | Bank1 |
| 1 | 0 | Bank2 if supported (see Table 22-1 on page 352). |
| 1 | 1 | Reserved |

This field may be updated one clock cycle after the RWALL bit changes, so the user should not poll this field as an interrupt bit.

- **NBUSYBK: Number of Busy Banks**

This field is set to indicate the number of busy banks:

| NBUSYBK | | Number of Busy Banks |
|---------|---|---|
| 0 | 0 | 0 (all banks free) |
| 0 | 1 | 1 |
| 1 | 0 | 2 |
| 1 | 1 | 3 if supported (see Table 22-1 on page 352). |

For IN endpoints, it indicates the number of banks filled by the user and ready for IN transfer. When all banks are free, this triggers an EPnINT interrupt if NBUSYBKE is one.

For OUT endpoints, it indicates the number of banks filled by OUT transactions from the host. When all banks are busy, this triggers an EPnINT interrupt if NBUSYBKE is one.

When the FIFOCON bit is cleared (by writing a one to the FIFOCONC bit) to validate a new bank, this field is updated two or three clock cycles later to calculate the address of the next bank.

An EPnINT interrupt is triggered if:

- for IN endpoint, NBUSYBKE is one and all the banks are free.
- for OUT endpoint, NBUSYBKE is one and all the banks are busy.

- **DTSEQ: Data Toggle Sequence**

This field is set to indicate the PID of the current bank:

| DTSEQ | | Data Toggle Sequence |
|-------|---|----------------------|
| 0 | 0 | Data0 |
| 0 | 1 | Data1 |
| 1 | X | Reserved |

For IN transfers, it indicates the data toggle sequence that will be used for the next packet to be sent. This is not relative to the current bank.

For OUT transfers, this value indicates the last data toggle sequence received on the current bank.

By default DTSEQ is 0b01, as if the last data toggle sequence was Data1, so the next sent or expected data toggle sequence should be Data0.

- **SHORTPACKET: Short Packet Interrupt**

This bit is set for non-control OUT endpoints, when a short packet has been received.

This bit is set for non-control IN endpoints, a short packet is transmitted upon ending a DMA transfer, thus signaling an end of isochronous frame or a bulk or interrupt end of transfer, this only if the End of DMA Buffer Output Enable (DMAENDEN) bit and the Automatic Switch (AUTOSW) bit are written to one.

This triggers an EPnINT interrupt if SHORTPACKETE is one.

This bit is cleared when the SHORTPACKETC bit is written to one. This will acknowledge the interrupt.

- **STALLEDI: STALLed Interrupt**

This bit is set to signal that a STALL handshake has been sent. To do that, the software has to set the STALLRQ bit (by writing a one to the STALLRQS bit). This triggers an EPnINT interrupt if STALLEDE is one.

This bit is cleared when the STALLEDIC bit is written to one. This will acknowledge the interrupt.

- **CRCERRI: CRC Error Interrupt**

This bit is set to signal that a CRC error has been detected in an isochronous OUT endpoint. The OUT packet is stored in the bank as if no CRC error had occurred. This triggers an EPnINT interrupt if CRCERRE is one.

This bit is cleared when the CRCERRIC bit is written to one. This will acknowledge the interrupt.

- **OVERFI: Overflow Interrupt**

This bit is set when an overflow error occurs. This triggers an EPnINT interrupt if OVERFE is one.

For all endpoint types, an overflow can occur during OUT stage if the host attempts to write into a bank that is too small for the packet. The packet is acknowledged and the RXOUTI bit is set as if no overflow had occurred. The bank is filled with all the first bytes of the packet that fit in.

This bit is cleared when the OVERFIC bit is written to one. This will acknowledge the interrupt.

- **NAKINI: NAKed IN Interrupt**

This bit is set when a NAK handshake has been sent in response to an IN request from the host. This triggers an EPnINT interrupt if NAKINE is one.

This bit is cleared when the NAKINIC bit is written to one. This will acknowledge the interrupt.

- **NAKOUTI: NAKed OUT Interrupt**

This bit is set when a NAK handshake has been sent in response to an OUT request from the host. This triggers an EPnINT interrupt if NAKOUTE is one.

This bit is cleared when the NAKOUTIC bit is written to one. This will acknowledge the interrupt.

- **UNDERFI: Underflow Interrupt**

This bit is set, for isochronous IN/OUT endpoints, when an underflow error occurs. This triggers an EPnINT interrupt if UNDERFE is one.

An underflow can occur during IN stage if the host attempts to read from an empty bank. A zero-length packet is then automatically sent by the USBB.

An underflow can also occur during OUT stage if the host sends a packet while the bank is already full. Typically, the CPU is not fast enough. The packet is lost.

Shall be cleared by writing a one to the UNDERFIC bit. This will acknowledge the interrupt.

This bit is inactive (cleared) for bulk and interrupt IN/OUT endpoints and it means RXSTPI for control endpoints.

- **RXSTPI: Received SETUP Interrupt**

This bit is set, for control endpoints, to signal that the current bank contains a new valid SETUP packet. This triggers an EPnINT interrupt if RXSTPE is one.

Shall be cleared by writing a one to the RXSTPIC bit. This will acknowledge the interrupt and free the bank.

This bit is inactive (cleared) for bulk and interrupt IN/OUT endpoints and it means UNDERFI for isochronous IN/OUT endpoints.

- **RXOUTI: Received OUT Data Interrupt**

This bit is set, for control endpoints, when the current bank contains a bulk OUT packet (data or status stage). This triggers an EPnINT interrupt if RXOUTE is one.

Shall be cleared for control end points, by writing a one to the RXOUTIC bit. This will acknowledge the interrupt and free the bank.

This bit is set for isochronous, bulk and, interrupt OUT endpoints, at the same time as FIFOCON when the current bank is full.

This triggers an EPnINT interrupt if RXOUTE is one.

Shall be cleared for isochronous, bulk and, interrupt OUT endpoints, by writing a one to the RXOUTIC bit. This will acknowledge the interrupt, what has no effect on the endpoint FIFO.

The user then reads from the FIFO and clears the FIFOCON bit to free the bank. If the OUT endpoint is composed of multiple banks, this also switches to the next bank. The RXOUTI and FIFOCON bits are set/cleared in accordance with the status of the next bank.

RXOUTI shall always be cleared before clearing FIFOCON.

This bit is inactive (cleared) for isochronous, bulk and interrupt IN endpoints.

- **TXINI: Transmitted IN Data Interrupt**

This bit is set for control endpoints, when the current bank is ready to accept a new IN packet. This triggers an EPnINT interrupt if TXINE is one.

This bit is cleared when the TXINIC bit is written to one. This will acknowledge the interrupt and send the packet.

This bit is set for isochronous, bulk and interrupt IN endpoints, at the same time as FIFOCON when the current bank is free.

This triggers an EPnINT interrupt if TXINE is one.

This bit is cleared when the TXINIC bit is written to one. This will acknowledge the interrupt, what has no effect on the endpoint FIFO.

The user then writes into the FIFO and clears the FIFOCON bit to allow the USBB to send the data. If the IN endpoint is composed of multiple banks, this also switches to the next bank. The TXINI and FIFOCON bits are set/cleared in accordance with the status of the next bank.

TXINI shall always be cleared before clearing FIFOCON.

This bit is inactive (cleared) for isochronous, bulk and interrupt OUT endpoints.

22.8.2.12 Endpoint n Status Clear Register

Register Name: UESTAnCLR, n in [0..6]

Access Type: Write-Only

Offset: 0x0160 + (n * 0x04)

Read Value: 0x00000000

| | | | | | | | |
|------------------|------------------------|---------|---------|----------|----------------------|---------|--------|
| 31 | 30 | 29 | 28 | 27 | 26 | 25 | 24 |
| - | - | - | - | - | - | - | - |
| 23 | 22 | 21 | 20 | 19 | 18 | 17 | 16 |
| - | - | - | - | - | - | - | - |
| 15 | 14 | 13 | 12 | 11 | 10 | 9 | 8 |
| - | - | - | - | - | - | - | - |
| 7 | 6 | 5 | 4 | 3 | 2 | 1 | 0 |
| SHORT PACKETC | STALLEDIC/ CRCERRIC | OVERFIC | NAKINIC | NAKOUTIC | RXSTPIC/ UNDERFIC | RXOUTIC | TXINIC |

Writing a one to a bit in this register will clear the corresponding bit in UESTA.

Writing a zero to a bit in this register has no effect.

This bit always reads as zero.

22.8.2.13 Endpoint n Status Set Register

Register Name: UESTAnSET, n in [0..6]

Access Type: Write-Only

Offset: 0x0190 + (n * 0x04)

Read Value: 0x00000000

| | | | | | | | |
|------------------|------------------------|---------|----------|----------|----------------------|---------|--------|
| 31 | 30 | 29 | 28 | 27 | 26 | 25 | 24 |
| - | - | - | - | - | - | - | - |
| 23 | 22 | 21 | 20 | 19 | 18 | 17 | 16 |
| - | - | - | - | - | - | - | - |
| 15 | 14 | 13 | 12 | 11 | 10 | 9 | 8 |
| - | - | - | NBUSYBKS | - | - | | - |
| 7 | 6 | 5 | 4 | 3 | 2 | 1 | 0 |
| SHORT PACKETS | STALLEDIS/ CRCERRIS | OVERFIS | NAKINIS | NAKOUTIS | RXSTPIS/ UNDERFIS | RXOUTIS | TXINIS |

Writing a one to a bit in this register will set the corresponding bit in UESTA, what may be useful for test or debug purposes.

Writing a zero to a bit in this register has no effect.

This bit always reads as zero.

22.8.2.14 Endpoint n Control Register

Register Name: UECONn, n in [0..6]

Access Type: Read-Only

Offset: 0x01C0 + (n * 0x04)

Reset Value: 0x00000000

| | | | | | | | |
|------------------|----------------------|--------|----------|---------|--------------------|--------|-----------|
| 31 | 30 | 29 | 28 | 27 | 26 | 25 | 24 |
| - | - | - | - | - | - | - | - |
| 23 | 22 | 21 | 20 | 19 | 18 | 17 | 16 |
| - | - | - | - | STALLRQ | RSTDT | - | EPDISHDMA |
| 15 | 14 | 13 | 12 | 11 | 10 | 9 | 8 |
| - | FIFOCON | KILLBK | NBUSYBKE | - | - | - | - |
| 7 | 6 | 5 | 4 | 3 | 2 | 1 | 0 |
| SHORT PACKETE | STALLEDE/ CRCERRE | OVERFE | NAKINE | NAKOUTE | RXSTPE/ UNDERFE | RXOUTE | TXINE |

- **STALLRQ: STALL Request**

This bit is set when the STALLRQS bit is written to one. This will request to send a STALL handshake to the host.

This bit is cleared when a new SETUP packet is received or when the STALLRQC bit is written to zero.

- **RSTDT: Reset Data Toggle**

This bit is set when the RSTDTS bit is written to one. This will clear the data toggle sequence, i.e., set to Data0 the data toggle sequence of the next sent (IN endpoints) or received (OUT endpoints) packet.

This bit is cleared instantaneously.

The user does not have to wait for this bit to be cleared.

- **EPDISHDMA: Endpoint Interrupts Disable HDMA Request Enable**

This bit is set when the EPDISHDMAS is written to one. This will pause the on-going DMA channel n transfer on any Endpoint n interrupt (EPnINT), whatever the state of the Endpoint n Interrupt Enable bit (EPnINTE).

The user then has to acknowledge or to disable the interrupt source (e.g. RXOUTI) or to clear the EPDISHDMA bit (by writing a one to the EPDISHDMAC bit) in order to complete the DMA transfer.

In ping-pong mode, if the interrupt is associated to a new system-bank packet (e.g. Bank1) and the current DMA transfer is running on the previous packet (Bank0), then the previous-packet DMA transfer completes normally, but the new-packet DMA transfer will not start (not requested).

If the interrupt is not associated to a new system-bank packet (NAKINI, NAKOUTI, etc.), then the request cancellation may occur at any time and may immediately pause the current DMA transfer.

This may be used for example to identify erroneous packets, to prevent them from being transferred into a buffer, to complete a DMA transfer by software after reception of a short packet, etc.

- **FIFOCON: FIFO Control**

For control endpoints:

The FIFOCON and RWALL bits are irrelevant. The software shall therefore never use them on these endpoints. When read, their value is always 0.

For IN endpoints:

This bit is set when the current bank is free, at the same time as TXINI.

This bit is cleared (by writing a one to the FIFOCONC bit) to send the FIFO data and to switch to the next bank.

For OUT endpoints:

This bit is set when the current bank is full, at the same time as RXOUTI.

This bit is cleared (by writing a one to the FIFOCONC bit) to free the current bank and to switch to the next bank.

- **KILLBK: Kill IN Bank**

This bit is set when the KILLBKS bit is written to one. This will kill the last written bank.

This bit is cleared by hardware after the completion of the “kill packet procedure”.

The user shall wait for this bit to be cleared before trying to process another IN packet.

Caution: The bank is cleared when the “kill packet” procedure is completed by the USB core :

If the bank is really killed, the NBUSYBK field is decremented.

If the bank is not “killed” but sent (IN transfer), the NBUSYBK field is decremented and the TXINI flag is set. This specific case can occur if at the same time an IN token is coming and the user wants to kill this bank.

Note : If two banks are ready to be sent, the above specific case can not occur, because the first bank is sent (IN transfer) while the last bank is killed.

- **NBUSYBKE: Number of Busy Banks Interrupt Enable**

This bit is set when the NBUSYBKES bit is written to one. This will enable the Number of Busy Banks interrupt (NBUSYBK).

This bit is cleared when the NBUSYBKEC bit is written to zero. This will disable the Number of Busy Banks interrupt (NBUSYBK).

- **SHORTPACKETE: Short Packet Interrupt Enable**

This bit is set when the SHORTPACKETES bit is written to one. This will enable the Short Packet interrupt (SHORTPACKET).

This bit is cleared when the SHORTPACKETEC bit is written to one. This will disable the Short Packet interrupt (SHORTPACKET).

- **STALLEDE: STALLed Interrupt Enable**

This bit is set when the STALLEDES bit is written to one. This will enable the STALLed interrupt (STALLEDI).

This bit is cleared when the STALLEDEC bit is written to one. This will disable the STALLed interrupt (STALLEDI).

- **CRCERRE: CRC Error Interrupt Enable**

This bit is set when the CRCERRES bit is written to one. This will enable the CRC Error interrupt (CRCERRI).

This bit is cleared when the CRCERREC bit is written to one. This will disable the CRC Error interrupt (CRCERRI).

- **OVERFE: Overflow Interrupt Enable**

This bit is set when the OVERFES bit is written to one. This will enable the Overflow interrupt (OVERFI).

This bit is cleared when the OVERFEC bit is written to one. This will disable the Overflow interrupt (OVERFI).

- **NAKINE: NAKed IN Interrupt Enable**

This bit is set when the NAKINES bit is written to one. This will enable the NAKed IN interrupt (NAKINI).

This bit is cleared when the NAKINEC bit is written to one. This will disable the NAKed IN interrupt (NAKINI).

- **NAKOUTE: NAKed OUT Interrupt Enable**

This bit is set when the NAKOUTES bit is written to one. This will enable the NAKed OUT interrupt (NAKOUTI).

This bit is cleared when the NAKOUTEC bit is written to one. This will disable the NAKed OUT interrupt (NAKOUTI).

- **RXSTPE: Received SETUP Interrupt Enable**

This bit is set when the RXSTPES bit is written to one. This will enable the Received SETUP interrupt (RXSTPI).

This bit is cleared when the RXSTPEC bit is written to one. This will disable the Received SETUP interrupt (RXSTPI).

- **UNDERFE: Underflow Interrupt Enable**

This bit is set when the UNDERFES bit is written to one. This will enable the Underflow interrupt (UNDERFI).

This bit is cleared when the UNDERFEC bit is written to one. This will disable the Underflow interrupt (UNDERFI).

- **RXOUTE: Received OUT Data Interrupt Enable**

This bit is set when the RXOUTES bit is written to one. This will enable the Received OUT Data interrupt (RXOUT).

This bit is cleared when the RXOUTEC bit is written to one. This will disable the Received OUT Data interrupt (RXOUT).

- **TXINE: Transmitted IN Data Interrupt Enable**

This bit is set when the TXINES bit is written to one. This will enable the Transmitted IN Data interrupt (TXINI).

This bit is cleared when the TXINEC bit is written to one. This will disable the Transmitted IN Data interrupt (TXINI).

22.8.2.15 Endpoint n Control Clear Register

Register Name: UECONnCLR, n in [0..6]

Access Type: Write-Only

Offset: 0x0220 + (n * 0x04)

Read Value: 0x00000000

| | | | | | | | |
|-------------------|------------------------|---------|-----------|----------|----------------------|---------|------------|
| 31 | 30 | 29 | 28 | 27 | 26 | 25 | 24 |
| - | - | - | - | - | - | - | - |
| 23 | 22 | 21 | 20 | 19 | 18 | 17 | 16 |
| - | - | - | - | STALLRQC | - | - | EPDISHDMAC |
| 15 | 14 | 13 | 12 | 11 | 10 | 9 | 8 |
| - | FIFOCONC | - | NBUSYBKEC | - | - | - | - |
| 7 | 6 | 5 | 4 | 3 | 2 | 1 | 0 |
| SHORT PACKETEC | STALLEDEC /CRCERREC | OVERFEC | NAKINEC | NAKOUTEC | RXSTPEC/ UNDERFEC | RXOUTEC | TXINEC |

Writing a one to a bit in this register will clear the corresponding bit in UECONn.

Writing a zero to a bit in this register has no effect.

This bit always reads as zero.

22.8.2.16 Endpoint n Control Set Register

Register Name: UECONnSET, n in [0..6]

Access Type: Write-Only

Offset: 0x01F0 + (n * 0x04)

Read Value: 0x00000000

| | | | | | | | |
|-------------------|------------------------|---------|-----------|----------|----------------------|---------|------------|
| 31 | 30 | 29 | 28 | 27 | 26 | 25 | 24 |
| - | - | - | - | - | - | - | - |
| 23 | 22 | 21 | 20 | 19 | 18 | 17 | 16 |
| - | - | - | - | STALLRQS | RSTDTS | - | EPDISHDMAS |
| 15 | 14 | 13 | 12 | 11 | 10 | 9 | 8 |
| - | - | KILLBKS | NBUSYBKES | - | - | - | - |
| 7 | 6 | 5 | 4 | 3 | 2 | 1 | 0 |
| SHORT PACKETES | STALLEDES/ CRCERRES | OVERFES | NAKINES | NAKOUTES | RXSTPES/ UNDERFES | RXOUTES | TXINES |

Writing a one to a bit in this register will set the corresponding bit in UECONn.

Writing a zero to a bit in this register has no effect.

This bit always reads as zero.

22.8.2.17 Device DMA Channel n Next Descriptor Address Register

Register Name: *UDDMAnNEXTDESC*, n in [1..6]

Access Type: Read/Write

Offset: $0x0310 + (n - 1) * 0x10$

Reset Value: 0x00000000

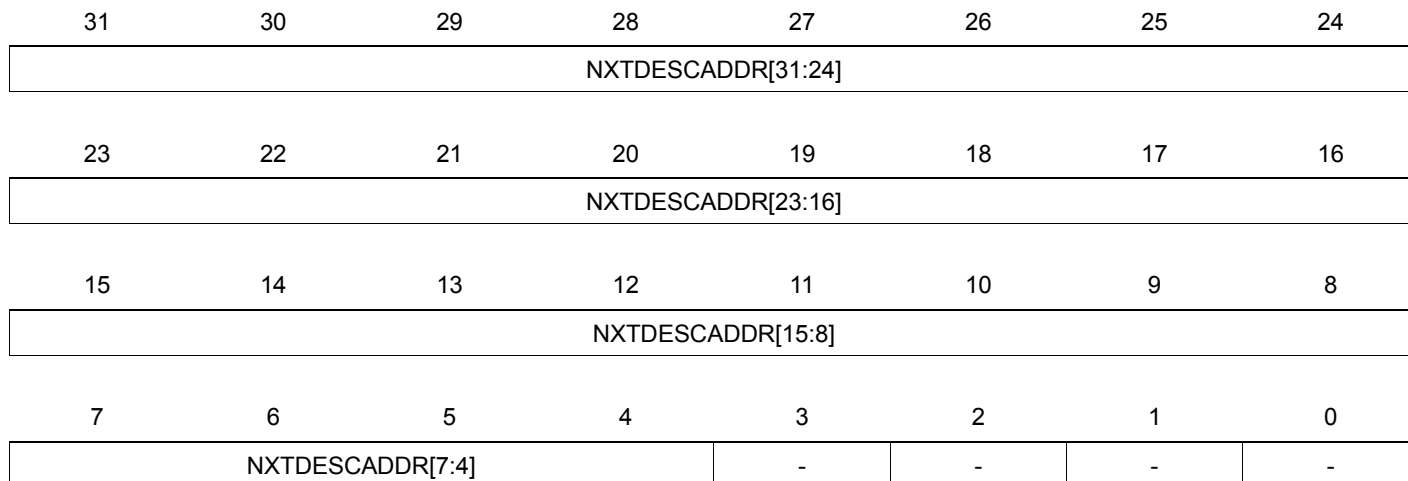

- **NXTDESCADDR: Next Descriptor Address**

This field contains the bits 31:4 of the 16-byte aligned address of the next channel descriptor to be processed.

This field is written either or by descriptor loading.

22.8.2.18 Device DMA Channel n HSB Address Register

Register Name: UDDMAnADDR, n in [1..6]

Access Type: Read/Write

Offset: 0x0314 + (n - 1) * 0x10

Reset Value: 0x00000000

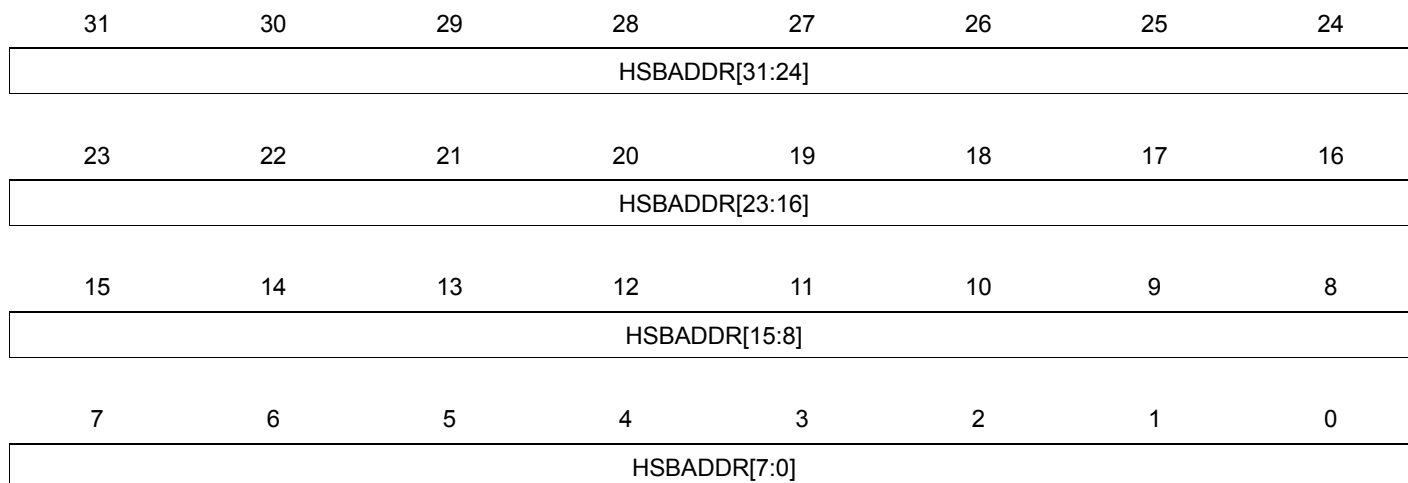

- **HSBADDR: HSB Address**

This field determines the HSB bus current address of a channel transfer.

The address written to the HSB address bus is HSBADDR rounded down to the nearest word-aligned address, i.e., HSBADDR[1:0] is considered as 0b00 since only word accesses are performed.

Channel HSB start and end addresses may be aligned on any byte boundary.

The user may write this field only when the Channel Enabled bit (CHEN) of the UDDMAnSTATUS register is cleared.

This field is updated at the end of the address phase of the current access to the HSB bus. It is incremented of the HSB access byte-width.

The HSB access width is 4 bytes, or less at packet start or end if the start or end address is not aligned on a word boundary.

The packet start address is either the channel start address or the next channel address to be accessed in the channel buffer.

The packet end address is either the channel end address or the latest channel address accessed in the channel buffer.

The channel start address is written or loaded from the descriptor, whereas the channel end address is either determined by the end of buffer or the end of USB transfer if the Buffer Close Input Enable bit (BUFFCLOSEINEN) is set.

22.8.2.19 Device DMA Channel n Control Register

Register Name: UDDMANCONTROL, n in [1..6]

Access Type: Read/Write

Offset: 0x0318 + (n - 1) * 0x10

Reset Value: 0x00000000

| | | | | | | | |
|--------------------|-------------|-------------|----------|----------|-------------------|-------------------|------|
| 31 | 30 | 29 | 28 | 27 | 26 | 25 | 24 |
| CHBYTELENGTH[15:8] | | | | | | | |
| 23 | 22 | 21 | 20 | 19 | 18 | 17 | 16 |
| CHBYTELENGTH[7:0] | | | | | | | |
| 15 | 14 | 13 | 12 | 11 | 10 | 9 | 8 |
| - | - | - | - | - | - | - | - |
| 7 | 6 | 5 | 4 | 3 | 2 | 1 | 0 |
| BURSTLOCKEN | DESCLDIRQEN | EOBUFFIRQEN | EOTIRQEN | DMAENDEN | BUFFCLOSE INEN | LDNXTCH DESCEN | CHEN |

- **CHBYTELENGTH: Channel Byte Length**

This field determines the total number of bytes to be transferred for this buffer.

The maximum channel transfer size 64kB is reached when this field is zero (default value).

If the transfer size is unknown, the transfer end is controlled by the peripheral and this field should be written to zero.

This field can be written or descriptor loading only after the UDDMANSTATUS.CHEN bit has been cleared, otherwise this field is ignored.

- **BURSTLOCKEN: Burst Lock Enable**

1: The USB data burst is locked for maximum optimization of HSB busses bandwidth usage and maximization of fly-by duration.

0: The DMA never locks the HSB access.

- **DESCLDIRQEN: Descriptor Loaded Interrupt Enable**

1: The Descriptor Loaded interrupt is enabled. This interrupt is generated when a Descriptor has been loaded from the system bus.

0: The Descriptor Loaded interrupt is disabled.

- **EOBUFFIRQEN: End of Buffer Interrupt Enable**

1: The end of buffer interrupt is enabled. This interrupt is generated when the channel byte count reaches zero.

0: The end of buffer interrupt is disabled.

- **EOTIRQEN: End of USB Transfer Interrupt Enable**

1: The end of usb OUT data transfer interrupt is enabled. This interrupt is generated only if the BUFFCLOSEINEN bit is set.

0: The end of usb OUT data transfer interrupt is disabled.

- **DMAENDEN: End of DMA Buffer Output Enable**

Writing a one to this bit will properly complete the usb transfer at the end of the dma transfer.

For IN endpoint, it means that a short packet (but not a Zero Length Packet) will be sent to the USB line to properly closed the usb transfer at the end of the dma transfer.

For OUT endpoint, it means that all the banks will be properly released. (NBUSYBK=0) at the end of the dma transfer.

- BUFFCLOSEINEN: Buffer Close Input Enable**
 For Bulk and Interrupt endpoint, writing a one to this bit will automatically close the current DMA transfer at the end of the USB OUT data transfer (received short packet).
 For Full-speed Isochronous, it does not make sense, so BUFFCLOSEINEN should be left to zero.
 Writing a zero to this bit to disable this feature.
- LDNXTCHDESCEN: Load Next Channel Descriptor Enable**
 1: the channel controller loads the next descriptor after the end of the current transfer, i.e. when the UDDMANSTATUS.CHEN bit is reset.
 0: no channel register is loaded after the end of the channel transfer.
 If the CHEN bit is written to zero, the next descriptor is immediately loaded upon transfer request (endpoint is free for IN endpoint, or endpoint is full for OUT endpoint).

Table 22-6. DMA Channel Control Command Summary

| LDNXTCHDESCEN | CHEN | Current Bank |
|---------------|------|-------------------------------|
| 0 | 0 | stop now |
| 0 | 1 | Run and stop at end of buffer |
| 1 | 0 | Load next descriptor now |
| 1 | 1 | Run and link at end of buffer |

- CHEN: Channel Enable**
 Writing this bit to zero will disabled the DMA channel and no transfer will occur upon request. If the LDNXTCHDESCEN bit is written to zero, the channel is frozen and the channel registers may then be read and/or written reliably as soon as both UDDMANSTATUS.CHEN and CHACTIVE bits are zero.
 Writing this bit to one will set the UDDMANSTATUS.CHEN bit and enable DMA channel data transfer. Then any pending request will start the transfer. This may be used to start or resume any requested transfer.
 This bit is cleared when the channel source bus is disabled at end of buffer. If the LDNXTCHDESCEN bit has been cleared by descriptor loading, the user will have to write to one the corresponding CHEN bit to start the described transfer, if needed.
 If a channel request is currently serviced when this bit is zero, the DMA FIFO buffer is drained until it is empty, then the UDDMANSTATUS.CHEN bit is cleared.
 If the LDNXTCHDESCEN bit is set or after this bit clearing, then the currently loaded descriptor is skipped (no data transfer occurs) and the next descriptor is immediately loaded.

22.8.2.20 Device DMA Channel n Status Register

Register Name: UDDMANSTATUS, n in [1..6]

Access Type: Read/Write

Offset: 0x031C + (n - 1) * 0x10

Reset Value: 0x00000000

| | | | | | | | |
|-----------------|---------------|-----------------|--------|----|----|----------|------|
| 31 | 30 | 29 | 28 | 27 | 26 | 25 | 24 |
| CHBYTECNT[15:8] | | | | | | | |
| 23 | 22 | 21 | 20 | 19 | 18 | 17 | 16 |
| CHBYTECNT[7:0] | | | | | | | |
| 15 | 14 | 13 | 12 | 11 | 10 | 9 | 8 |
| - | - | - | - | - | - | - | - |
| 7 | 6 | 5 | 4 | 3 | 2 | 1 | 0 |
| - | DESCLD STA | EOCHBUFF STA | EOTSTA | - | - | CHACTIVE | CHEN |

- **CHBYTECNT: Channel Byte Count**

This field contains the current number of bytes still to be transferred for this buffer.

This field is decremented at each dma access.

This field is reliable (stable) only if the CHEN bit is zero.

- **DESCLDSTA: Descriptor Loaded Status**

This bit is set when a Descriptor has been loaded from the HSB bus.

This bit is cleared when read by the user.

- **EOCHBUFFSTA: End of Channel Buffer Status**

This bit is set when the Channel Byte Count counts down to zero.

This bit is automatically cleared when read by software.

- **EOTSTA: End of USB Transfer Status**

This bit is set when the completion of the usb data transfer has closed the dma transfer. It is valid only if

UDDMANCONTROL.BUFFCLOSEINEN is one. Note that for OUT endpoint, if the UECFGn.AUTOSW is set, any received zero-length-packet will be cancelled by the DMA, and the EOTSTA will be set whatever the UDDMANCONTROL.CHEN bit is.

This bit is automatically cleared when read by software.

- **CHACTIVE: Channel Active**

0: the DMA channel is no longer trying to source the packet data.

1: the DMA channel is currently trying to source packet data, i.e. selected as the highest-priority requesting channel. When a packet transfer cannot be completed due to an EOCHBUFFSTA, this bit stays set during the next channel descriptor load (if any) and potentially until USB packet transfer completion, if allowed by the new descriptor.

When programming a DMA by descriptor (Load next descriptor now), the CHACTIVE bit is set only once the DMA is running (the endpoint is free for IN transaction, the endpoint is full for OUT transaction).

- **CHEN: Channel Enabled**

This bit is set (after one cycle latency) when the L.CHEN is written to one or when the descriptor is loaded.

This bit is cleared when any transfer is ended either due to an elapsed byte count or a USB device initiated transfer end.

0: the DMA channel no longer transfers data, and may load the next descriptor if the UDDMAnCONTROL.LDNXTCHDESCEN bit is zero.

1: the DMA channel is currently enabled and transfers data upon request.

If a channel request is currently serviced when the UDDMAnCONTROL.CHEN bit is written to zero, the DMA FIFO buffer is drained until it is empty, then this status bit is cleared.

22.8.3 USB Host Registers

22.8.3.1 Host General Control Register

Register Name: UHCON
Access Type: Read/Write
Offset: 0x0400
Reset Value: 0x00000000

| | | | | | | | |
|----|----|----|----|----|--------|-------|------|
| 31 | 30 | 29 | 28 | 27 | 26 | 25 | 24 |
| - | - | - | - | - | - | - | - |
| 23 | 22 | 21 | 20 | 19 | 18 | 17 | 16 |
| - | - | - | - | - | - | - | - |
| 15 | 14 | 13 | 12 | 11 | 10 | 9 | 8 |
| - | - | - | - | - | RESUME | RESET | SOFE |
| 7 | 6 | 5 | 4 | 3 | 2 | 1 | 0 |
| - | - | - | - | - | - | - | - |

- RESUME: Send USB Resume**
 Writing a one to this bit will generate a USB Resume on the USB bus.
 This bit is cleared when the USB Resume has been sent or when a USB reset is requested.
 Writing a zero to this bit has no effect.
 This bit should be written to one only when the start of frame generation is enable. (SOFE bit is one).
- RESET: Send USB Reset**
 Writing a one to this bit will generate a USB Reset on the USB bus.
 This bit is cleared when the USB Reset has been sent.
 It may be useful to write a zero to this bit when a device disconnection is detected (UHINT.DDISCI is one) whereas a USB Reset is being sent.
- SOFE: Start of Frame Generation Enable**
 Writing a one to this bit will generate SOF on the USB bus in full speed mode and keep alive in low speed mode.
 Writing a zero to this bit will disable the SOF generation and to leave the USB bus in idle state.
 This bit is set when a USB reset is requested or an upstream resume interrupt is detected (UHINT.RXRSMI).



22.8.3.2 Host Global Interrupt Register

Register Name: UHINT
Access Type: Read-Only
Offset: 0x0404
Reset Value: 0x00000000

| | | | | | | | |
|----|---------|---------|---------|---------|---------|---------|--------|
| 31 | 30 | 29 | 28 | 27 | 26 | 25 | 24 |
| - | DMA6INT | DMA5INT | DMA4INT | DMA3INT | DMA2INT | DMA1INT | - |
| 23 | 22 | 21 | 20 | 19 | 18 | 17 | 16 |
| - | - | - | - | - | - | - | - |
| 15 | 14 | 13 | 12 | 11 | 10 | 9 | 8 |
| - | P6INT | P5INT | P4INT | P3INT | P2INT | P1INT | POINT |
| 7 | 6 | 5 | 4 | 3 | 2 | 1 | 0 |
| - | HWUPI | HOFI | RXRSMI | RSMEI | RSTI | DDISCI | DCONNI |

- DMA n INT: DMA Channel n Interrupt**
 This bit is set when an interrupt is triggered by the DMA channel n . This triggers a USB interrupt if the corresponding DMA n INTE is one (UHINTE register).
 This bit is cleared when the UHDMANSTATUS interrupt source is cleared.
- P n INT: Pipe n Interrupt**
 This bit is set when an interrupt is triggered by the endpoint n (UPSTAN). This triggers a USB interrupt if the corresponding pipe interrupt enable bit is one (UHINTE register).
 This bit is cleared when the interrupt source is served.
- HWUPI: Host Wake-Up Interrupt**
 This bit is set when the host controller is in the suspend mode (SOFE is zero) and an upstream resume from the peripheral is detected.
 This bit is set when the host controller is in the suspend mode (SOFE is zero) and a peripheral disconnection is detected.
 This bit is set when the host controller is in the Idle state (USBSTA.VBUSRQ is zero, no VBus is generated).
 This interrupt is generated even if the clock is frozen by the FRZCLK bit.
- HOFI: Host Start of Frame Interrupt**
 This bit is set when a SOF is issued by the Host controller. This triggers a USB interrupt when HOFI is one. When using the host controller in low speed mode, this bit is also set when a keep-alive is sent.
 This bit is cleared when the HOFIC bit is written to one.
- RXRSMI: Upstream Resume Received Interrupt**
 This bit is set when an Upstream Resume has been received from the Device.
 This bit is cleared when the RXRSMIC is written to one.
- RSMEI: Downstream Resume Sent Interrupt**
 This bit set when a Downstream Resume has been sent to the Device.
 This bit is cleared when the RSMEIC bit is written to one.
- RSTI: USB Reset Sent Interrupt**
 This bit is set when a USB Reset has been sent to the device.
 This bit is cleared when the RSTIC bit is written to one.

- **DDISCI: Device Disconnection Interrupt**
This bit is set when the device has been removed from the USB bus.
This bit is cleared when the DDISCIC bit is written to one.
- **DCONNI: Device Connection Interrupt**
This bit is set when a new device has been connected to the USB bus.
This bit is cleared when the DCONNIC bit is written to one.

22.8.3.3 Host Global Interrupt Clear Register

Register Name: UHINTCLR

Access Type: Write-Only

Offset: 0x0408

Read Value: 0x00000000

| | | | | | | | |
|----|--------|--------|---------|---------|-------|---------|---------|
| 31 | 30 | 29 | 28 | 27 | 26 | 25 | 24 |
| - | - | - | - | - | - | - | - |
| 23 | 22 | 21 | 20 | 19 | 18 | 17 | 16 |
| - | - | - | - | - | - | - | - |
| 15 | 14 | 13 | 12 | 11 | 10 | 9 | 8 |
| - | - | - | - | - | - | - | - |
| 7 | 6 | 5 | 4 | 3 | 2 | 1 | 0 |
| - | HWUPIC | HSOFIC | RXRSMIC | RSMEDIC | RSTIC | DDISCIC | DCONNIC |

Writing a one to a bit in this register will clear the corresponding bit in UHINT.

Writing a zero to a bit in this register has no effect.

This bit always reads as zero.

22.8.3.4 Host Global Interrupt Set Register

Register Name: UHINTSET
Access Type: Write-Only
Offset: 0x040C
Read Value: 0x00000000

| | | | | | | | |
|----|----------|----------|----------|----------|----------|----------|---------|
| 31 | 30 | 29 | 28 | 27 | 26 | 25 | 24 |
| - | DMA6INTS | DMA5INTS | DMA4INTS | DMA3INTS | DMA2INTS | DMA1INTS | - |
| 23 | 22 | 21 | 20 | 19 | 18 | 17 | 16 |
| - | - | - | - | - | - | - | - |
| 15 | 14 | 13 | 12 | 11 | 10 | 9 | 8 |
| - | - | - | - | - | - | - | - |
| 7 | 6 | 5 | 4 | 3 | 2 | 1 | 0 |
| - | HWUPIS | HSOFIS | RXRSMIS | RSMEDIS | RSTIS | DDISCIS | DCONNIS |

Writing a one to a bit in this register will set the corresponding bit in UHINT, what may be useful for test or debug purposes.
 Writing a zero to a bit in this register has no effect.
 This bit always reads as zero.

22.8.3.5 Host Global Interrupt Enable Register

Register Name: UHINTE
Access Type: Read-Only
Offset: 0x0410
Reset Value: 0x00000000

| | | | | | | | |
|----|----------|----------|----------|----------|----------|----------|---------|
| 31 | 30 | 29 | 28 | 27 | 26 | 25 | 24 |
| - | DMA6INTE | DMA5INTE | DMA4INTE | DMA3INTE | DMA2INTE | DMA1INTE | - |
| 23 | 22 | 21 | 20 | 19 | 18 | 17 | 16 |
| - | - | - | - | - | - | - | - |
| 15 | 14 | 13 | 12 | 11 | 10 | 9 | 8 |
| - | P6INTE | P5INTE | P4INTE | P3INTE | P2INTE | P1INTE | POINTE |
| 7 | 6 | 5 | 4 | 3 | 2 | 1 | 0 |
| - | HWUPIE | HSOFIE | RXRSMIE | RSMEDIE | RSTIE | DDISCIE | DCONNIE |

- **DMA_nINTE: DMA Channel n Interrupt Enable**
 This bit is set when the DMA_nINTES bit is written to one. This will enable the DMA Channel n Interrupt (DMA_nINT).
 This bit is cleared when the DMA_nINTEC bit is written to one. This will disable the DMA Channel n Interrupt (DMA_nINT).
- **P_nINTE: Pipe n Interrupt Enable**
 This bit is set when the P_nINTES bit is written to one. This will enable the Pipe n Interrupt (P_nINT).
 This bit is cleared when the P_nINTEC bit is written to one. This will disable the Pipe n Interrupt (P_nINT).
- **HWUPIE: Host Wake-Up Interrupt Enable**
 This bit is set when the HWUPIES bit is written to one. This will enable the Host Wake-up Interrupt (HWUPI).
 This bit is cleared when the HWUPIEC bit is written to one. This will disable the Host Wake-up Interrupt (HWUPI).
- **HSOFIE: Host Start of Frame Interrupt Enable**
 This bit is set when the HSOFIES bit is written to one. This will enable the Host Start of Frame interrupt (HSOFI).
 This bit is cleared when the HSOFIEC bit is written to one. This will disable the Host Start of Frame interrupt (HSOFI).
- **RXRSMIE: Upstream Resume Received Interrupt Enable**
 This bit is set when the RXRSMIES bit is written to one. This will enable the Upstream Resume Received interrupt (RXRSMI).
 This bit is cleared when the RXRSMIEC bit is written to one. This will disable the Downstream Resume interrupt (RXRSMI).
- **RSMEDIE: Downstream Resume Sent Interrupt Enable**
 This bit is set when the RSMEDIES bit is written to one. This will enable the Downstream Resume interrupt (RSMEDI).
 This bit is cleared when the RSMEDIEC bit is written to one. This will disable the Downstream Resume interrupt (RSMEDI).
- **RSTIE: USB Reset Sent Interrupt Enable**
 This bit is set when the RSTIES bit is written to one. This will enable the USB Reset Sent interrupt (RSTI).
 This bit is cleared when the RSTIEC bit is written to one. This will disable the USB Reset Sent interrupt (RSTI).
- **DDISCIE: Device Disconnection Interrupt Enable**
 This bit is set when the DDISCIES bit is written to one. This will enable the Device Disconnection interrupt (DDISCI).
 This bit is cleared when the DDISCIEC bit is written to one. This will disable the Device Disconnection interrupt (DDISCI).
- **DCONNIE: Device Connection Interrupt Enable**
 This bit is set when the DCONNIES bit is written to one. This will enable the Device Connection interrupt (DCONNI).
 This bit is cleared when the DCONNIEC bit is written to one. This will disable the Device Connection interrupt (DCONNI).



22.8.3.6 Host Global Interrupt Enable Clear Register

Register Name: UHINTECLR

Access Type: Write-Only

Offset: 0x0414

Read Value: 0x00000000

| | | | | | | | |
|----|-----------|-----------|-----------|-----------|-----------|-----------|----------|
| 31 | 30 | 29 | 28 | 27 | 26 | 25 | 24 |
| - | DMA6INTEC | DMA5INTEC | DMA4INTEC | DMA3INTEC | DMA2INTEC | DMA1INTEC | - |
| 23 | 22 | 21 | 20 | 19 | 18 | 17 | 16 |
| - | - | - | - | - | - | - | - |
| 15 | 14 | 13 | 12 | 11 | 10 | 9 | 8 |
| - | P6INTEC | P5INTEC | P4INTEC | P3INTEC | P2INTEC | P1INTEC | P0INTEC |
| 7 | 6 | 5 | 4 | 3 | 2 | 1 | 0 |
| - | HWUPIEC | HSOFIEC | RXRSMIEC | RSMEDIEC | RSTIEC | DDISCIEC | DCONNIEC |

Writing a one to a bit in this register will clear the corresponding bit in UHINTE.

Writing a zero to a bit in this register has no effect.

This bit always reads as zero.

22.8.3.7 Host Global Interrupt Enable Set Register

Register Name: UHINTESET

Access Type: Write-Only

Offset: 0x0418

Read Value: 0x00000000

| | | | | | | | |
|----|-----------|-----------|-----------|-----------|-----------|-----------|----------|
| 31 | 30 | 29 | 28 | 27 | 26 | 25 | 24 |
| - | DMA6INTES | DMA5INTES | DMA4INTES | DMA3INTES | DMA2INTES | DMA1INTES | - |
| 23 | 22 | 21 | 20 | 19 | 18 | 17 | 16 |
| - | - | - | - | - | - | - | - |
| 15 | 14 | 13 | 12 | 11 | 10 | 9 | 8 |
| - | P6INTES | P5INTES | P4INTES | P3INTES | P2INTES | P1INTES | P0INTES |
| 7 | 6 | 5 | 4 | 3 | 2 | 1 | 0 |
| - | HWUPIES | HSOFIES | RXRSMIES | RSMEDIES | RSTIES | DDISCIES | DCONNIES |

Writing a one to a bit in this register will set the corresponding bit in UHINT.

Writing a zero to a bit in this register has no effect.

This bit always reads as zero.

22.8.3.8 Host Frame Number Register

Register Name: UHFNUM
Access Type: Read/Write
Offset: 0x0420
Reset Value: 0x00000000

| | | | | | | | | |
|-----------|----|------------|----|----|----|----|----|---|
| 31 | 30 | 29 | 28 | 27 | 26 | 25 | 24 | |
| - | - | - | - | - | - | - | - | |
| 23 | 22 | 21 | 20 | 19 | 18 | 17 | 16 | |
| FLENHIGH | | | | | | | | |
| 15 | 14 | 13 | 12 | 11 | 10 | 9 | 8 | |
| - | - | FNUM[10:5] | | | | | | - |
| 7 | 6 | 5 | 4 | 3 | 2 | 1 | 0 | |
| FNUM[4:0] | | | | | - | - | - | |

- **FLENHIGH: Frame Length**

This field contains the 8 high-order bits of the 14-bits internal frame counter (frame counter at 12MHz, counter length is 12000 to ensure a SOF generation every 1 ms).

- **FNUM: Frame Number**

This field contains the current SOF number.

This field can be written.

22.8.3.9 Host Address 1 Register

Register Name: UHADDR1
Access Type: Read/Write
Offset: 0x0424
Reset Value: 0x00000000

| | | | | | | | |
|----|----------|----|----|----|----|----|----|
| 31 | 30 | 29 | 28 | 27 | 26 | 25 | 24 |
| - | UHADDRP3 | | | | | | |
| 23 | 22 | 21 | 20 | 19 | 18 | 17 | 16 |
| - | UHADDRP2 | | | | | | |
| 15 | 14 | 13 | 12 | 11 | 10 | 9 | 8 |
| - | UHADDRP1 | | | | | | |
| 7 | 6 | 5 | 4 | 3 | 2 | 1 | 0 |
| - | UHADDRP0 | | | | | | |

- UHADDRP3: USB Host Address**
 This field contains the address of the Pipe3 of the USB Device.
 This field is cleared when a USB reset is requested.
- UHADDRP2: USB Host Address**
 This field contains the address of the Pipe2 of the USB Device.
 This field is cleared when a USB reset is requested.
- UHADDRP1: USB Host Address**
 This field contains the address of the Pipe1 of the USB Device.
 This field is cleared when a USB reset is requested.
- UHADDRP0: USB Host Address**
 This field contains the address of the Pipe0 of the USB Device.
 This field is cleared when a USB reset is requested.

22.8.3.10 Host Address 2 Register

Register Name: UHADDR2
Access Type: Read/Write
Offset: 0x0428
Reset Value: 0x00000000

| | | | | | | | |
|----|----------|----|----|----|----|----|----|
| 31 | 30 | 29 | 28 | 27 | 26 | 25 | 24 |
| - | - | - | - | - | - | - | - |
| 23 | 22 | 21 | 20 | 19 | 18 | 17 | 16 |
| - | UHADDRP6 | | | | | | |
| 15 | 14 | 13 | 12 | 11 | 10 | 9 | 8 |
| - | UHADDRP5 | | | | | | |
| 7 | 6 | 5 | 4 | 3 | 2 | 1 | 0 |
| - | UHADDRP4 | | | | | | |

- **UHADDRP6: USB Host Address**
 This field contains the address of the Pipe6 of the USB Device.
 This field is cleared when a USB reset is requested.
- **UHADDRP5: USB Host Address**
 This field contains the address of the Pipe5 of the USB Device.
 This field is cleared when a USB reset is requested.
- **UHADDRP4: USB Host Address**
 This field contains the address of the Pipe4 of the USB Device.
 This field is cleared when a USB reset is requested.

22.8.3.11 Pipe Enable/Reset Register

Register Name: UPRST
Access Type: Read/Write
Offset: 0x0041C
Reset Value: 0x00000000

| | | | | | | | |
|----|-------|-------|-------|-------|-------|-------|-------|
| 31 | 30 | 29 | 28 | 27 | 26 | 25 | 24 |
| - | - | - | - | - | - | - | - |
| 23 | 22 | 21 | 20 | 19 | 18 | 17 | 16 |
| - | PRST6 | PRST5 | PRST4 | PRST3 | PRST2 | PRST1 | PRST0 |
| 15 | 14 | 13 | 12 | 11 | 10 | 9 | 8 |
| - | - | - | - | - | - | - | - |
| 7 | 6 | 5 | 4 | 3 | 2 | 1 | 0 |
| - | PEN6 | PEN5 | PEN4 | PEN3 | PEN2 | PEN1 | PEN0 |

- **PRSTn: Pipe n Reset**

Writing a one to this bit will reset the Pipe n FIFO.

This resets the endpoint n registers (UPCFGn, UPSTAn, UPCONn) but not the endpoint configuration (ALLOC, PBK, PSIZE, PTOKEN, PTYPE, PEPNUM, INTFRQ).

All the endpoint mechanism (FIFO counter, reception, transmission, etc.) is reset apart from the Data Toggle management.

The endpoint configuration remains active and the endpoint is still enabled.

Writing a zero to this bit will complete the reset operation and allow to start using the FIFO.

- **PENn: Pipe n Enable**

Writing a one to this bit will enable the Pipe n.

Writing a zero to this bit will disable the Pipe n, what forces the Pipe n state to inactive and resets the pipe n registers (UPCFGn, UPSTAn, UPCONn) but not the pipe configuration (ALLOC, PBK, PSIZE).

22.8.3.12 Pipe n Configuration Register

Register Name: UPCFGn, n in [0..6]

Access Type: Read/Write

Offset: 0x0500 + (n * 0x04)

Reset Value: 0x00000000

| | | | | | | | |
|--------|-------|-------|----|--------|--------|--------|----|
| 31 | 30 | 29 | 28 | 27 | 26 | 25 | 24 |
| INTFRQ | | | | | | | |
| 23 | 22 | 21 | 20 | 19 | 18 | 17 | 16 |
| - | - | - | - | PEPNUM | | | |
| 15 | 14 | 13 | 12 | 11 | 10 | 9 | 8 |
| - | - | PTYPE | | - | AUTOSW | PTOKEN | |
| 7 | 6 | 5 | 4 | 3 | 2 | 1 | 0 |
| - | PSIZE | | | PBK | | ALLOC | - |

- **INTFRQ: Pipe Interrupt Request Frequency**

This field contains the maximum value in millisecond of the polling period for an Interrupt Pipe.

This value has no effect for a non-Interrupt Pipe.

This field is cleared upon sending a USB reset.

- **PEPNUM: Pipe Endpoint Number**

This field contains the number of the endpoint targeted by the pipe. This value is from 0 to 15.

This field is cleared upon sending a USB reset.

- **PTYPE: Pipe Type**

This field contains the pipe type.

| PTYPE | | Pipe Type |
|-------|---|-------------|
| 0 | 0 | Control |
| 0 | 1 | Isochronous |
| 1 | 0 | Bulk |
| 1 | 1 | Interrupt |

This field is cleared upon sending a USB reset.

- **AUTOSW: Automatic Switch**

This bit is cleared upon sending a USB reset.

1: The automatic bank switching is enabled.

0: The automatic bank switching is disabled.

- **PTOKEN: Pipe Token**

This field contains the endpoint token.

| PTOKEN | Endpoint Direction |
|--------|--------------------|
| 00 | SETUP |
| 01 | IN |
| 10 | OUT |
| 11 | reserved |

- **PSIZE: Pipe Size**

This field contains the size of each pipe bank.

| PSIZE | | | Endpoint Size |
|-------|---|---|---------------|
| 0 | 0 | 0 | 8 bytes |
| 0 | 0 | 1 | 16 bytes |
| 0 | 1 | 0 | 32 bytes |
| 0 | 1 | 1 | 64 bytes |
| 1 | 0 | 0 | 128 bytes |
| 1 | 0 | 1 | 256 bytes |
| 1 | 1 | 0 | 512 bytes |
| 1 | 1 | 1 | 1024 bytes |

This field is cleared upon sending a USB reset.

- **PBK: Pipe Banks**

This field contains the number of banks for the pipe.

| PBK | | Endpoint Banks |
|-----|---|--|
| 0 | 0 | 1 (single-bank pipe) |
| 0 | 1 | 2 (double-bank pipe) |
| 1 | 0 | 3 (triple-bank pipe) if supported (see Table 22-1 on page 352). |
| 1 | 1 | Reserved |

For control endpoints, a single-bank pipe (0b00) should be selected.

This field is cleared upon sending a USB reset.

- **ALLOC: Pipe Memory Allocate**

Writing a one to this bit will allocate the pipe memory.

Writing a zero to this bit will free the pipe memory.

This bit is cleared when a USB Reset is requested.

Refer to the DPRAM Management chapter for more details.

22.8.3.13 Pipe n Status Register

Register Name: UPSTAn, n in [0..6]

Access Type: Read-Only

Offset: 0x0530 + (n * 0x04)

Reset Value: 0x00000000

| | | | | | | | |
|------------------|----------------------|---------|--------|-------|--------------------|--------|-------|
| 31 | 30 | 29 | 28 | 27 | 26 | 25 | 24 |
| - | PBYCT[10:4] | | | | | | |
| 23 | 22 | 21 | 20 | 19 | 18 | 17 | 16 |
| PBYCT[3:0] | | | | - | CFGOK | - | RWALL |
| 15 | 14 | 13 | 12 | 11 | 10 | 9 | 8 |
| CURRBK | | NBUSYBK | | - | - | DTSEQ | |
| 7 | 6 | 5 | 4 | 3 | 2 | 1 | 0 |
| SHORT PACKETI | RXSTALLI/ CRCERRI | OVERFI | NAKEDI | PERRI | TXSTPI/ UNDERFI | TXOUTI | RXINI |

- **PBYCT: Pipe Byte Count**

This field contains the byte count of the FIFO.

For OUT pipe, incremented after each byte written by the user into the pipe and decremented after each byte sent to the peripheral.

For IN pipe, incremented after each byte received from the peripheral and decremented after each byte read by the user from the pipe.

This field may be updated 1 clock cycle after the RWALL bit changes, so the user should not poll this field as an interrupt bit.

- **CFGOK: Configuration OK Status**

This bit is set/cleared when the UPCFGn.ALLOC bit is set.

This bit is set if the pipe n number of banks (UPCFGn.PBK) and size (UPCFGn.PSIZE) are correct compared to the maximal allowed number of banks and size for this pipe and to the maximal FIFO size (i.e., the DPRAM size).

If this bit is cleared, the user should rewrite correct values of the PBK and PSIZE field in the UPCFGn register.

- **RWALL: Read/Write Allowed**

For OUT pipe, this bit is set when the current bank is not full, i.e., the software can write further data into the FIFO.

For IN pipe, this bit is set when the current bank is not empty, i.e., the software can read further data from the FIFO.

This bit is cleared otherwise.

This bit is also cleared when the RXSTALL or the PERR bit is one.

- **CURRBK: Current Bank**

For non-control pipe, this field indicates the number of the current bank.

| CURRBK | | Current Bank |
|--------|---|--------------|
| 0 | 0 | Bank0 |

| CURRBK | | Current Bank |
|--------|---|---|
| 0 | 1 | Bank1 |
| 1 | 0 | Bank2 if supported (see Table 22-1 on page 352). |
| 1 | 1 | Reserved |

This field may be updated 1 clock cycle after the RWALL bit changes, so the user shall not poll this field as an interrupt bit.

- **NBUSYBK: Number of Busy Banks**

This field indicates the number of busy bank.

For OUT pipe, this field indicates the number of busy bank(s), filled by the user, ready for OUT transfer. When all banks are busy, this triggers an PnINT interrupt if UPCONn.NBUSYBKE is one.

For IN pipe, this field indicates the number of busy bank(s) filled by IN transaction from the Device. When all banks are free, this triggers an PnINT interrupt if UPCONn.NBUSYBKE is one.

| NBUSYBK | | Number of busy bank |
|---------|---|--|
| 0 | 0 | All banks are free. |
| 0 | 1 | 1 busy bank |
| 1 | 0 | 2 busy banks if supported (see Table 22-1 on page 352). |
| 1 | 1 | reserved |

- **DTSEQ: Data Toggle Sequence**

This field indicates the data PID of the current bank.

| DTSEQ | | Data toggle sequence |
|-------|---|----------------------|
| 0 | 0 | Data0 |
| 0 | 1 | Data1 |
| 1 | 0 | reserved |
| 1 | 1 | reserved |

For OUT pipe, this field indicates the data toggle of the next packet that will be sent.

For IN pipe, this field indicates the data toggle of the received packet stored in the current bank.

- **SHORTPACKETI: Short Packet Interrupt**

This bit is set when a short packet is received by the host controller (packet length inferior to the PSIZE programmed field).

This bit is cleared when the SHORTPACKETIC bit is written to one.

- **RXSTALLDI: Received STALLed Interrupt**

This bit is set, for all endpoints but isochronous, when a STALL handshake has been received on the current bank of the pipe.

The Pipe is automatically frozen. This triggers an interrupt if the RXSTALLE bit is one.

This bit is cleared when the RXSTALLDIC bit is written to one.

- **CRCERRI: CRC Error Interrupt**

This bit is set, for isochronous endpoint, when a CRC error occurs on the current bank of the Pipe. This triggers an interrupt if the TXSTPE bit is one.

This bit is cleared when the CRCERRIC bit is written to one.

- **OVERFI: Overflow Interrupt**

This bit is set when the current pipe has received more data than the maximum length of the current pipe. An interrupt is triggered if the OVERFIE bit is one.

This bit is cleared when the OVERFIC bit is written to one.

- **NAKEDI: NAKed Interrupt**

This bit is set when a NAK has been received on the current bank of the pipe. This triggers an interrupt if the NAKEDE bit is one.

This bit is cleared when the NAKEDIC bit is written to one.

- **PERRI: Pipe Error Interrupt**

This bit is set when an error occurs on the current bank of the pipe. This triggers an interrupt if the PERRE bit is set. Refers to the UPERRn register to determine the source of the error.

This bit is cleared when the error source bit is cleared.

- **TXSTPI: Transmitted SETUP Interrupt**

This bit is set, for Control endpoints, when the current SETUP bank is free and can be filled. This triggers an interrupt if the TXSTPE bit is one.

This bit is cleared when the TXSTPIC bit is written to one.

- **UNDERFI: Underflow Interrupt**

This bit is set, for isochronous and Interrupt IN/OUT pipe, when an error flow occurs. This triggers an interrupt if the UNDERFIE bit is one.

This bit is set, for Isochronous or interrupt OUT pipe, when a transaction underflow occurs in the current pipe. (the pipe can't send the OUT data packet in time because the current bank is not ready). A zero-length-packet (ZLP) will be sent instead of.

This bit is set, for Isochronous or interrupt IN pipe, when a transaction flow error occurs in the current pipe. i.e, the current bank of the pipe is not free whereas a new IN USB packet is received. This packet is not stored in the bank. For Interrupt pipe, the overflowed packet is ACKed to respect the USB standard.

This bit is cleared when the UNDERFIEC bit is written to one.

- **TXOUTI: Transmitted OUT Data Interrupt**

This bit is set when the current OUT bank is free and can be filled. This triggers an interrupt if the TXOUTE bit is one.

This bit is cleared when the TXOUTIC bit is written to one.

- **RXINI: Received IN Data Interrupt**

This bit is set when a new USB message is stored in the current bank of the pipe. This triggers an interrupt if the RXINE bit is one.

This bit is cleared when the RXINIC bit is written to one.

22.8.3.14 Pipe n Status Clear Register

Register Name: UPSTAnCLR, n in [0..6]

Access Type: Write-Only

Offset: 0x0560 + (n * 0x04)

Read Value: 0x00000000

| | | | | | | | |
|-------------------|-----------------------------|---------|---------|----|----------------------|---------|--------|
| 31 | 30 | 29 | 28 | 27 | 26 | 25 | 24 |
| - | - | - | - | - | - | - | - |
| 23 | 22 | 21 | 20 | 19 | 18 | 17 | 16 |
| - | - | - | - | - | - | - | - |
| 15 | 14 | 13 | 12 | 11 | 10 | 9 | 8 |
| - | - | - | - | - | - | - | - |
| 7 | 6 | 5 | 4 | 3 | 2 | 1 | 0 |
| SHORT PACKETIC | RXSTALLDI C/ CRCERRIC | OVERFIC | NAKEDIC | - | TXSTPIC/ UNDERFIC | TXOUTIC | RXINIC |

Writing a one to a bit in this register will clear the corresponding bit in UPSTAn.

Writing a zero to a bit in this register has no effect.

This bit always reads as zero.

22.8.3.15 Pipe n Status Set Register

Register Name: UPSTAnSET, n in [0..6]

Access Type: Write-Only

Offset: 0x0590 + (n * 0x04)

Read Value: 0x00000000

| | | | | | | | |
|-------------------|-------------------------|---------|----------|--------|----------------------|---------|--------|
| 31 | 30 | 29 | 28 | 27 | 26 | 25 | 24 |
| - | - | - | - | - | - | - | - |
| 23 | 22 | 21 | 20 | 19 | 18 | 17 | 16 |
| - | - | - | - | - | - | - | - |
| 15 | 14 | 13 | 12 | 11 | 10 | 9 | 8 |
| - | - | - | NBUSYBKS | - | - | - | - |
| 7 | 6 | 5 | 4 | 3 | 2 | 1 | 0 |
| SHORT PACKETIS | RXSTALLDIS/ CRCERRIS | OVERFIS | NAKEDIS | PERRIS | TXSTPIS/ UNDERFIS | TXOUTIS | RXINIS |

Writing a one to a bit in this register will set the corresponding bit in UPSTAn, what may be useful for test or debug purposes.

Writing a zero to a bit in this register has no effect.

This bit always reads as zero.

22.8.3.16 Pipe n Control Register

Register Name: UPCONn, n in [0..6]

Access Type: Read-Only

Offset: 0x05C0 + (n * 0x04)

Reset Value: 0x00000000

| | | | | | | | |
|-------------------|-----------------------|---------|----------|-------|---------------------|---------|----------|
| 31 | 30 | 29 | 28 | 27 | 26 | 25 | 24 |
| - | - | - | - | - | - | - | - |
| 23 | 22 | 21 | 20 | 19 | 18 | 17 | 16 |
| - | - | - | - | - | RSTDT | PFREEZE | PDISHDMA |
| 15 | 14 | 13 | 12 | 11 | 10 | 9 | 8 |
| - | FIFOCON | - | NBUSYBKE | - | - | - | - |
| 7 | 6 | 5 | 4 | 3 | 2 | 1 | 0 |
| SHORT PACKETIE | RXSTALLDE /CRCERRE | OVERFIE | NAKEDE | PERRE | TXSTPE/ UNDERFIE | TXOUTE | RXINE |

- **RSTDT: Reset Data Toggle**

This bit is set when the RSTDTs bit is written to one. This will reset the Data Toggle to its initial value for the current Pipe.

This bit is cleared when proceed.

- **PFREEZE: Pipe Freeze**

This bit is set when the PFREEZES bit is written to one or when the pipe is not configured or when a STALL handshake has been received on this Pipe or when an error occurs on the Pipe (PERR is one) or when (INRQ+1) In requests have been processed or when after a Pipe reset (UPRST.PRSTn rising) or a Pipe Enable (UPRST.PEN rising). This will Freeze the Pipe requests generation.

This bit is cleared when the PFREEZEC bit is written to one. This will enable the Pipe request generation.

- **PDISHDMA: Pipe Interrupts Disable HDMA Request Enable**

See the UECONn.EPDISHDMA bit description.

- **FIFOCON: FIFO Control**

For OUT and SETUP Pipe:

This bit is set when the current bank is free, at the same time than TXOUTI or TXSTPI.

This bit is cleared when the FIFOCONC bit is written to one. This will send the FIFO data and switch the bank.

For IN Pipe:

This bit is set when a new IN message is stored in the current bank, at the same time than RXINI.

This bit is cleared when the FIFOCONC bit is written to one. This will free the current bank and switch to the next bank.

- **NBUSYBKE: Number of Busy Banks Interrupt Enable**

This bit is set when the NBUSYBKES bit is written to one. This will enable the Transmitted IN Data interrupt (NBUSYBKE).

This bit is cleared when the NBUSYBKEC bit is written to one. This will disable the Transmitted IN Data interrupt (NBUSYBKE).

- **SHORTPACKETIE: Short Packet Interrupt Enable**

This bit is set when the SHORTPACKETES bit is written to one. This will enable the Transmitted IN Data IT (SHORTPACKETIE).

This bit is cleared when the SHORTPACKETEC bit is written to one. This will disable the Transmitted IN Data IT (SHORTPACKETE).



- **RXSTALLDE: Received STALLed Interrupt Enable**
This bit is set when the RXSTALLDES bit is written to one. This will enable the Transmitted IN Data interrupt (RXSTALLDE).
This bit is cleared when the RXSTALLDEC bit is written to one. This will disable the Transmitted IN Data interrupt (RXSTALLDE).
- **CRCERRE: CRC Error Interrupt Enable**
This bit is set when the CRCERRES bit is written to one. This will enable the Transmitted IN Data interrupt (CRCERRE).
This bit is cleared when the CRCERREC bit is written to one. This will disable the Transmitted IN Data interrupt (CRCERRE).
- **OVERFIE: Overflow Interrupt Enable**
This bit is set when the OVERFIES bit is written to one. This will enable the Transmitted IN Data interrupt (OVERFIE).
This bit is cleared when the OVERFIEC bit is written to one. This will disable the Transmitted IN Data interrupt (OVERFIE).
- **NAKEDE: NAKed Interrupt Enable**
This bit is set when the NAKEDES bit is written to one. This will enable the Transmitted IN Data interrupt (NAKEDE).
This bit is cleared when the NAKEDec bit is written to one. This will disable the Transmitted IN Data interrupt (NAKEDE).
- **PERRE: Pipe Error Interrupt Enable**
This bit is set when the PERRES bit is written to one. This will enable the Transmitted IN Data interrupt (PERRE).
This bit is cleared when the PERREC bit is written to one. This will disable the Transmitted IN Data interrupt (PERRE).
- **TXSTPE: Transmitted SETUP Interrupt Enable**
This bit is set when the TXSTPES bit is written to one. This will enable the Transmitted IN Data interrupt (TXSTPE).
This bit is cleared when the TXSTPEC bit is written to one. This will disable the Transmitted IN Data interrupt (TXSTPE).
- **UNDERFIE: Underflow Interrupt Enable**
This bit is set when the UNDERFIES bit is written to one. This will enable the Transmitted IN Data interrupt (UNDERFIE).
This bit is cleared when the UNDERFIEC bit is written to one. This will disable the Transmitted IN Data interrupt (UNDERFIE).
- **TXOUTE: Transmitted OUT Data Interrupt Enable**
This bit is set when the TXOUTES bit is written to one. This will enable the Transmitted IN Data interrupt (TXOUTE).
This bit is cleared when the TXOUTEC bit is written to one. This will disable the Transmitted IN Data interrupt (TXOUTE).
- **RXINE: Received IN Data Interrupt Enable**
This bit is set when the RXINES bit is written to one. This will enable the Transmitted IN Data interrupt (RXINE).
This bit is cleared when the RXINEC bit is written to one. This will disable the Transmitted IN Data interrupt (RXINE).

22.8.3.17 Pipe n Control Clear Register

Register Name: UPCONnCLR, n in [0..6]

Access Type: Write-Only

Offset: 0x0620 + (n * 0x04)

Read Value: 0x00000000

| | | | | | | | |
|--------------------|-------------------------|----------|-----------|--------|-----------------------|----------|-----------|
| 31 | 30 | 29 | 28 | 27 | 26 | 25 | 24 |
| - | - | - | - | - | - | - | - |
| 23 | 22 | 21 | 20 | 19 | 18 | 17 | 16 |
| - | - | - | - | - | - | PFREEZEC | PDISHDMAC |
| 15 | 14 | 13 | 12 | 11 | 10 | 9 | 8 |
| - | FIFOCONC | - | NBUSYBKEC | - | - | - | - |
| 7 | 6 | 5 | 4 | 3 | 2 | 1 | 0 |
| SHORT PACKETIEC | RXSTALLDEC /CRCERREC | OVERFIEC | NAKEDEC | PERREC | TXSTPEC/ UNDERFIEC | TXOUTEC | RXINEC |

Writing a one to a bit in this register will clear the corresponding bit in UPCONn.

Writing a zero to a bit in this register has no effect.

This bit always reads as zero.

22.8.3.18 Pipe n Control Set Register

Register Name: UPCONnSET, n in [0..6]

Access Type: Write-Only

Offset: 0x05F0 + (n * 0x04)

Read Value: 0x00000000

| | | | | | | | |
|--------------------|-------------------------|----------|-----------|--------|-----------------------|----------|-----------|
| 31 | 30 | 29 | 28 | 27 | 26 | 25 | 24 |
| - | - | - | - | - | - | - | - |
| 23 | 22 | 21 | 20 | 19 | 18 | 17 | 16 |
| - | - | - | - | - | RSTDTS | PFREEZES | PDISHDMAS |
| 15 | 14 | 13 | 12 | 11 | 10 | 9 | 8 |
| - | - | - | NBUSYBKES | - | - | - | - |
| 7 | 6 | 5 | 4 | 3 | 2 | 1 | 0 |
| SHORT PACKETIES | RXSTALLDES/ CRCERRES | OVERFIES | NAKEDES | PERRES | TXSTPES/ UNDERFIES | TXOUTES | RXINES |

Writing a one to a bit in this register will set the corresponding bit in UPCONn.

Writing a zero to a bit in this register has no effect.

This bit always reads as zero.

22.8.3.19 Pipe n IN Request Register

Register Name: UPINRQn, n in [0..6]

Access Type: Read/Write

Offset: 0x0650 + (n * 0x04)

Reset Value: 0x00000000

| | | | | | | | |
|------|----|----|----|----|----|----|--------|
| 31 | 30 | 29 | 28 | 27 | 26 | 25 | 24 |
| - | - | - | - | - | - | - | - |
| 23 | 22 | 21 | 20 | 19 | 18 | 17 | 16 |
| - | - | - | - | - | - | - | - |
| 15 | 14 | 13 | 12 | 11 | 10 | 9 | 8 |
| - | - | - | - | - | - | - | INMODE |
| 7 | 6 | 5 | 4 | 3 | 2 | 1 | 0 |
| INRQ | | | | | | | |

- **INMODE: IN Request Mode**

Writing a one to this bit will allow the USBB to perform infinite IN requests when the Pipe is not frozen.

Writing a zero to this bit will perform a pre-defined number of IN requests. This number is the INRQ field.

- **INRQ: IN Request Number before Freeze**

This field contains the number of IN transactions before the USBB freezes the pipe. The USBB will perform (INRQ+1) IN requests before to freeze the Pipe. This counter is automatically decreased by 1 each time a IN request has been successfully performed.

This register has no effect when the INMODE bit is one (infinite IN requests generation till the pipe is not frozen).

22.8.3.20 Pipe n Error Register

Register Name: UPERRn, n in [0..6]

Access Type: Read/Write

Offset: 0x0680 + (n * 0x04)

Reset Value: 0x00000000

| | | | | | | | |
|----|---------|----|-------|---------|-----|---------|---------|
| 31 | 30 | 29 | 28 | 27 | 26 | 25 | 24 |
| - | - | - | - | - | - | - | - |
| 23 | 22 | 21 | 20 | 19 | 18 | 17 | 16 |
| - | - | - | - | - | - | - | - |
| 15 | 14 | 13 | 12 | 11 | 10 | 9 | 8 |
| - | - | - | - | - | - | - | - |
| 7 | 6 | 5 | 4 | 3 | 2 | 1 | 0 |
| - | COUNTER | | CRC16 | TIMEOUT | PID | DATAPID | DATATGL |

- **COUNTER: Error Counter**

This field is incremented each time an error occurs (CRC16, TIMEOUT, PID, DATAPID or DATATGL).

This field is cleared when receiving a good usb packet without any error.

When this field reaches 3 (i.e., 3 consecutive errors), this pipe is automatically frozen (UPCONn.PFREEZE is set).

Writing 0b00 to this field will clear the counter.

- **CRC16: CRC16 Error**

This bit is set when a CRC16 error has been detected.

Writing a zero to this bit will clear the bit.

Writing a one to this bit has no effect.

- **TIMEOUT: Time-Out Error**

This bit is set when a Time-Out error has been detected.

Writing a zero to this bit will clear the bit.

Writing a one to this bit has no effect.

- **PID: PID Error**

This bit is set when a PID error has been detected.

Writing a zero to this bit will clear the bit.

Writing a one to this bit has no effect.

- **DATAPID: Data PID Error**

This bit is set when a Data PID error has been detected.

Writing a zero to this bit will clear the bit.

Writing a one to this bit has no effect.

- **DATATGL: Data Toggle Error**

This bit is set when a Data Toggle error has been detected.

Writing a zero to this bit will clear the bit.

Writing a one to this bit has no effect.

22.8.3.21 Host DMA Channel n Next Descriptor Address Register

Register Name: UHDMAnNEXTDESC, n in [1..6]

Access Type: Read/Write

Offset: 0x0710 + (n - 1) * 0x10

Reset Value: 0x00000000

| | | | | | | | |
|--------------------|----|----|----|----|----|----|----|
| 31 | 30 | 29 | 28 | 27 | 26 | 25 | 24 |
| NXTDESCADDR[31:24] | | | | | | | |
| 23 | 22 | 21 | 20 | 19 | 18 | 17 | 16 |
| NXTDESCADDR[23:16] | | | | | | | |
| 15 | 14 | 13 | 12 | 11 | 10 | 9 | 8 |
| NXTDESCADDR[15:8] | | | | | | | |
| 7 | 6 | 5 | 4 | 3 | 2 | 1 | 0 |
| NXTDESCADDR[7:4] | | | | - | - | - | - |

Same as [Section 22.8.2.17](#).

22.8.3.22 Host DMA Channel n HSB Address Register

Register Name: UHDMAnADDR, n in [1..6]

Access Type: Read/Write

Offset: 0x0714 + (n - 1) * 0x10

Reset Value: 0x00000000

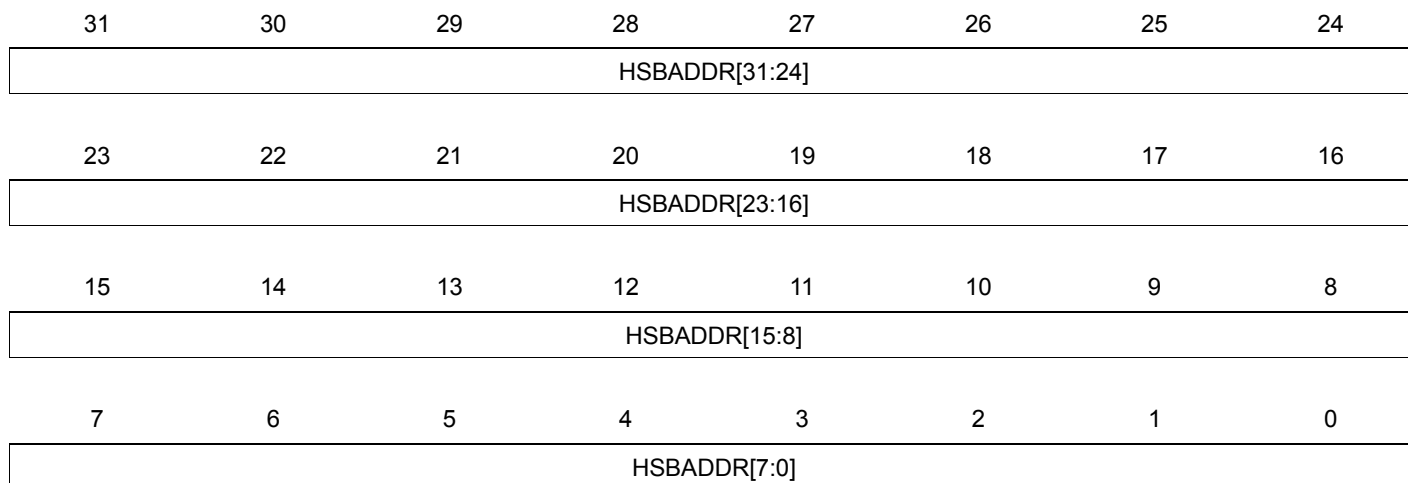

Same as [Section 22.8.2.18](#).

22.8.3.23 USB Host DMA Channel n Control Register

Register Name: UHDMAnCONTROL, n in [1..6]

Access Type: Read/Write

Offset: 0x0718 + (n - 1) * 0x10

Reset Value: 0x00000000

| | | | | | | | |
|--------------------|-----------------|-----------------|----------|----------|-------------------|-------------------|------|
| 31 | 30 | 29 | 28 | 27 | 26 | 25 | 24 |
| CHBYTELENGTH[15:8] | | | | | | | |
| 23 | 22 | 21 | 20 | 19 | 18 | 17 | 16 |
| CHBYTELENGTH[7:0] | | | | | | | |
| 15 | 14 | 13 | 12 | 11 | 10 | 9 | 8 |
| - | - | - | - | - | - | - | - |
| 7 | 6 | 5 | 4 | 3 | 2 | 1 | 0 |
| BURSTLOC KEN | DESCLD IRQEN | EOBUFF IRQEN | EOTIRQEN | DMAENDEN | BUFFCLOSE INEN | LDNXTCHD ESCEN | CHEN |

Same as [Section 22.8.2.19](#).

(just replace the IN endpoint term by OUT endpoint, and vice-versa)

22.8.3.24 USB Host DMA Channel n Status Register

Register Name: UHDMAnSTATUS, n in [1..6]

Access Type: Read/Write

Offset: 0x071C + (n - 1) * 0x10

Reset Value: 0x00000000

| | | | | | | | |
|-----------------|---------------|-----------------|--------|----|----|----------|------|
| 31 | 30 | 29 | 28 | 27 | 26 | 25 | 24 |
| CHBYTECNT[15:8] | | | | | | | |
| 23 | 22 | 21 | 20 | 19 | 18 | 17 | 16 |
| CHBYTECNT[7:0] | | | | | | | |
| 15 | 14 | 13 | 12 | 11 | 10 | 9 | 8 |
| - | - | - | - | - | - | - | - |
| 7 | 6 | 5 | 4 | 3 | 2 | 1 | 0 |
| - | DESCLD STA | EOCHBUFFS TA | EOTSTA | - | - | CHACTIVE | CHEN |

Same as [Section 22.8.2.20](#).

22.8.4 USB Pipe/Endpoint n FIFO Data Register (USBFIFO_nDATA)

The application has access to the physical DPRAM reserved for the Endpoint/Pipe through a 64KB virtual address space. The application can access anywhere in the virtual 64KB segment (linearly or fixedly) as the DPRAM Fifo address increment is fully handled by hardware. Byte, half-word and word access are supported. Data should be access in a big-endian way.

For instance, if the application wants to write into the Endpoint/Pipe3, it can access anywhere in the USBFIFO3DATA HSB segment address. i.e : an access to the 0x30000 offset, is strictly equivalent to an access to the 0x3FFFC offset.

Note that the virtual address space size (64KB) has nothing to do with the Endpoint/Pipe size.

Disabling the USBB (by writing a zero to the USBE bit) does not reset the DPRAM.

23. Timer/Counter (TC)

Rev: 2.2.2.3

23.1 Features

- **Three 16-bit Timer Counter channels**
- **A wide range of functions including:**
 - Frequency measurement
 - Event counting
 - Interval measurement
 - Pulse generation
 - Delay timing
 - Pulse width modulation
 - Up/down capabilities
- **Each channel is user-configurable and contains:**
 - Three external clock inputs
 - Five internal clock inputs
 - Two multi-purpose input/output signals
- **Internal interrupt signal**
- **Two global registers that act on all three TC channels**

23.2 Overview

The Timer Counter (TC) includes three identical 16-bit Timer Counter channels.

Each channel can be independently programmed to perform a wide range of functions including frequency measurement, event counting, interval measurement, pulse generation, delay timing, and pulse width modulation.

Each channel has three external clock inputs, five internal clock inputs, and two multi-purpose input/output signals which can be configured by the user. Each channel drives an internal interrupt signal which can be programmed to generate processor interrupts.

The TC block has two global registers which act upon all three TC channels.

The Block Control Register (BCR) allows the three channels to be started simultaneously with the same instruction.

The Block Mode Register (BMR) defines the external clock inputs for each channel, allowing them to be chained.

23.3 Block Diagram

Figure 23-1. TC Block Diagram

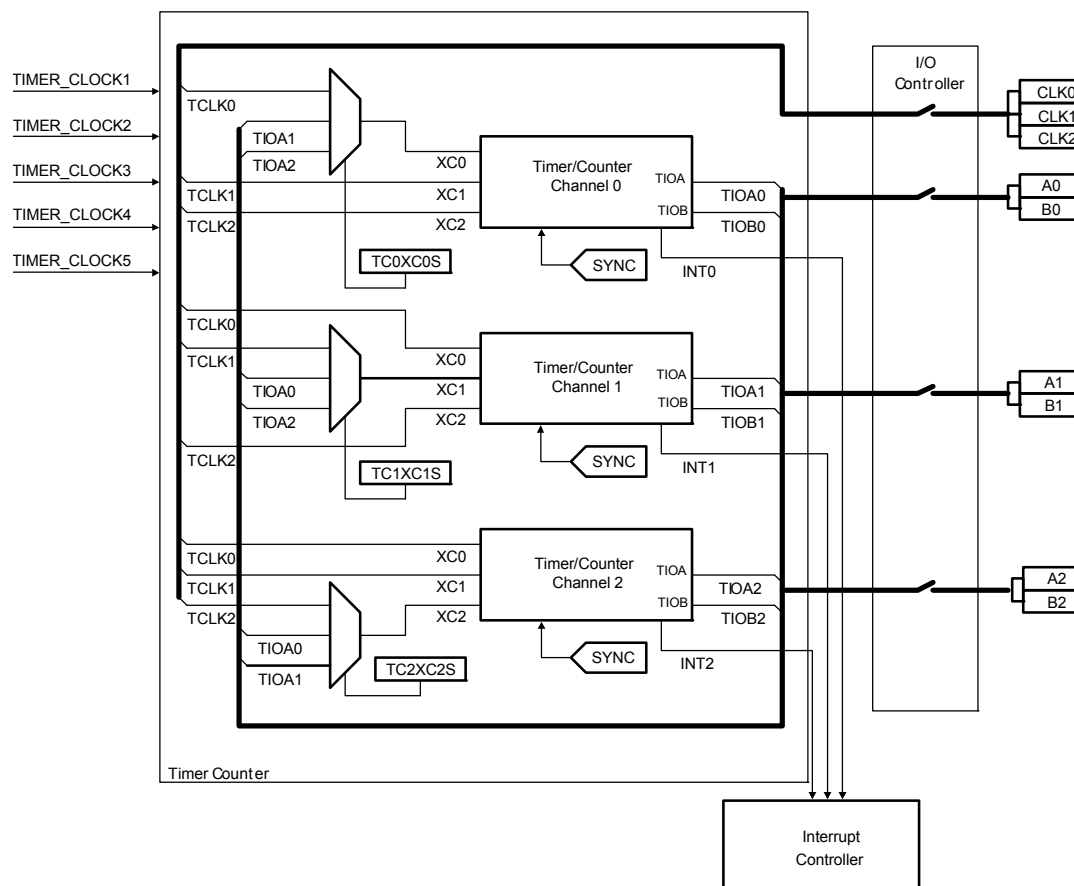

23.4 I/O Lines Description

Table 23-1. I/O Lines Description

| Pin Name | Description | Type |
|-----------|----------------------|--------------|
| CLK0-CLK2 | External Clock Input | Input |
| A0-A2 | I/O Line A | Input/Output |
| B0-B2 | I/O Line B | Input/Output |

23.5 Product Dependencies

In order to use this module, other parts of the system must be configured correctly, as described below.

23.5.1 I/O Lines

The pins used for interfacing the compliant external devices may be multiplexed with I/O lines. The user must first program the I/O Controller to assign the TC pins to their peripheral functions.

23.5.2 Power Management

If the CPU enters a sleep mode that disables clocks used by the TC, the TC will stop functioning and resume operation after the system wakes up from sleep mode.

23.5.3 Clocks

The clock for the TC bus interface (CLK_TC) is generated by the Power Manager. This clock is enabled at reset, and can be disabled in the Power Manager. It is recommended to disable the TC before disabling the clock, to avoid freezing the TC in an undefined state.

23.5.4 Interrupts

The TC interrupt request line is connected to the interrupt controller. Using the TC interrupt requires the interrupt controller to be programmed first.

23.5.5 Debug Operation

The Timer Counter clocks are frozen during debug operation, unless the OCD system keeps peripherals running in debug operation.

23.6 Functional Description

23.6.1 TC Description

The three channels of the Timer Counter are independent and identical in operation. The registers for channel programming are listed in [Figure 23-3 on page 489](#).

23.6.1.1 Channel I/O Signals

As described in [Figure 23-1 on page 473](#), each Channel has the following I/O signals.

Table 23-2. Channel I/O Signals Description

| Block/Channel | Signal Name | Description |
|----------------|---------------|--|
| Channel Signal | XC0, XC1, XC2 | External Clock Inputs |
| | TIOA | Capture mode: Timer Counter Input Waveform mode: Timer Counter Output |
| | TIOB | Capture mode: Timer Counter Input Waveform mode: Timer Counter Input/Output |
| | INT | Interrupt Signal Output |
| | SYNC | Synchronization Input Signal |

23.6.1.2 16-bit counter

Each channel is organized around a 16-bit counter. The value of the counter is incremented at each positive edge of the selected clock. When the counter has reached the value 0xFFFF and passes to 0x0000, an overflow occurs and the Counter Overflow Status bit in the Channel n Status Register (SRn.COVFS) is set.

The current value of the counter is accessible in real time by reading the Channel n Counter Value Register (CVn). The counter can be reset by a trigger. In this case, the counter value passes to 0x0000 on the next valid edge of the selected clock.

23.6.1.3 Clock selection

At block level, input clock signals of each channel can either be connected to the external inputs TCLK0, TCLK1 or TCLK2, or be connected to the configurable I/O signals A0, A1 or A2 for chaining by writing to the BMR register. See [Figure 23-2 on page 475](#).

Each channel can independently select an internal or external clock source for its counter:

- Internal clock signals: TIMER_CLOCK1, TIMER_CLOCK2, TIMER_CLOCK3, TIMER_CLOCK4, TIMER_CLOCK5. See the Module Configuration Chapter for details about the connection of these clock sources.
- External clock signals: XC0, XC1 or XC2. See the Module Configuration Chapter for details about the connection of these clock sources.

This selection is made by the Clock Selection field in the Channel n Mode Register (CMRn.TCCLKS).

The selected clock can be inverted with the Clock Invert bit in CMRn (CMRn.CLKI). This allows counting on the opposite edges of the clock.

The burst function allows the clock to be validated when an external signal is high. The Burst Signal Selection field in the CMRn register (CMRn.BURST) defines this signal.

Note: In all cases, if an external clock is used, the duration of each of its levels must be longer than the CLK_TC period. The external clock frequency must be at least 2.5 times lower than the CLK_TC.

Figure 23-2. Clock Selection

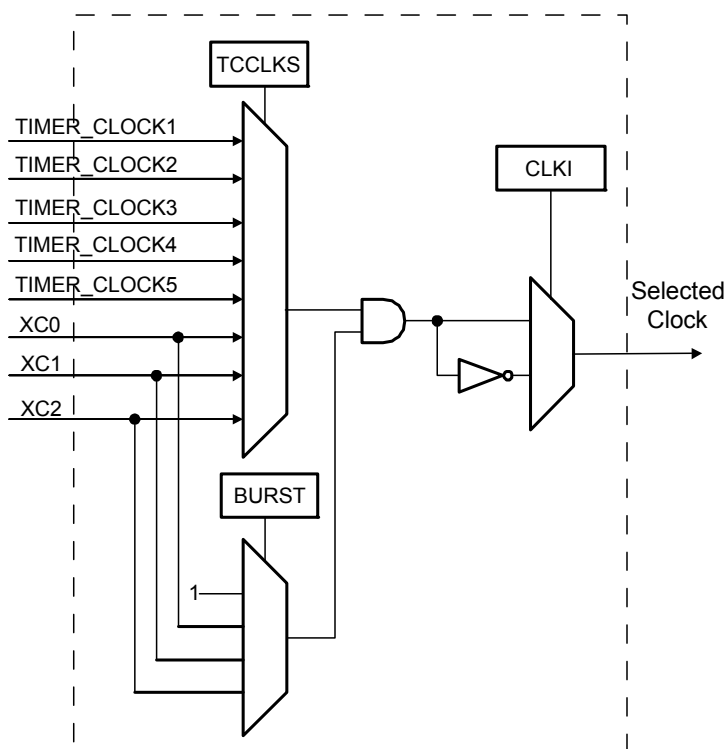

23.6.1.4 Clock control

The clock of each counter can be controlled in two different ways: it can be enabled/disabled and started/stopped. See [Figure 23-3 on page 476](#).

- The clock can be enabled or disabled by the user by writing to the Counter Clock Enable/Disable Command bits in the Channel n Clock Control Register (CCRn.CLKEN and CCRn.CLKDIS). In Capture mode it can be disabled by an RB load event if the Counter Clock Disable with RB Loading bit in CMRn is written to one (CMRn.LDBDIS). In Waveform mode, it can be disabled by an RC Compare event if the Counter Clock Disable with RC Compare bit in CMRn is written to one (CMRn.CPCDIS). When disabled, the start or the stop actions have no effect: only a CLKEN command in CCRn can re-enable the clock. When the clock is enabled, the Clock Enabling Status bit is set in SRn (SRn.CLKSTA).
- The clock can also be started or stopped: a trigger (software, synchro, external or compare) always starts the clock. In Capture mode the clock can be stopped by an RB load event if the Counter Clock Stopped with RB Loading bit in CMRn is written to one (CMRn.LDBSTOP). In Waveform mode it can be stopped by an RC compare event if the Counter Clock Stopped with RC Compare bit in CMRn is written to one (CMRn.CPCSTOP). The start and the stop commands have effect only if the clock is enabled.

Figure 23-3. Clock Control

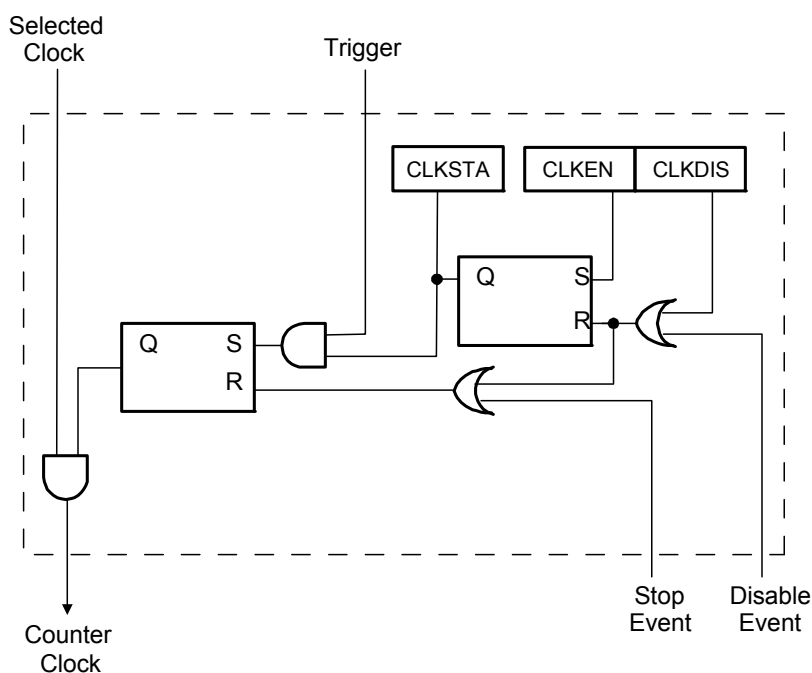

23.6.1.5 TC operating modes

Each channel can independently operate in two different modes:

- Capture mode provides measurement on signals.
- Waveform mode provides wave generation.

The TC operating mode selection is done by writing to the Wave bit in the CCRn register (CCRn.WAVE).

In Capture mode, TIOA and TIOB are configured as inputs.

In Waveform mode, TIOA is always configured to be an output and TIOB is an output if it is not selected to be the external trigger.

23.6.1.6 Trigger

A trigger resets the counter and starts the counter clock. Three types of triggers are common to both modes, and a fourth external trigger is available to each mode.

The following triggers are common to both modes:

- Software Trigger: each channel has a software trigger, available by writing a one to the Software Trigger Command bit in CCRn (CCRn.SWTRG).
- SYNC: each channel has a synchronization signal SYNC. When asserted, this signal has the same effect as a software trigger. The SYNC signals of all channels are asserted simultaneously by writing a one to the Synchro Command bit in the BCR register (BCR.SYNC).
- Compare RC Trigger: RC is implemented in each channel and can provide a trigger when the counter value matches the RC value if the RC Compare Trigger Enable bit in CMRn (CMRn.CPCTRG) is written to one.

The channel can also be configured to have an external trigger. In Capture mode, the external trigger signal can be selected between TIOA and TIOB. In Waveform mode, an external event can be programmed to be one of the following signals: TIOB, XC0, XC1, or XC2. This external event can then be programmed to perform a trigger by writing a one to the External Event Trigger Enable bit in CMRn (CMRn.ENETRIG).

If an external trigger is used, the duration of the pulses must be longer than the CLK_TC period in order to be detected.

Regardless of the trigger used, it will be taken into account at the following active edge of the selected clock. This means that the counter value can be read differently from zero just after a trigger, especially when a low frequency signal is selected as the clock.

23.6.2 Capture Operating Mode

This mode is entered by writing a zero to the CMRn.WAVE bit.

Capture mode allows the TC channel to perform measurements such as pulse timing, frequency, period, duty cycle and phase on TIOA and TIOB signals which are considered as inputs.

[Figure 23-4 on page 479](#) shows the configuration of the TC channel when programmed in Capture mode.

23.6.2.1 Capture registers A and B

Registers A and B (RA and RB) are used as capture registers. This means that they can be loaded with the counter value when a programmable event occurs on the signal TIOA.

The RA Loading Selection field in CMRn (CMRn.LDRA) defines the TIOA edge for the loading of the RA register, and the RB Loading Selection field in CMRn (CMRn.LDRB) defines the TIOA edge for the loading of the RB register.

RA is loaded only if it has not been loaded since the last trigger or if RB has been loaded since the last loading of RA.

RB is loaded only if RA has been loaded since the last trigger or the last loading of RB.

Loading RA or RB before the read of the last value loaded sets the Load Overrun Status bit in SRn (SRn.LOVRN). In this case, the old value is overwritten.

23.6.2.2 *Trigger conditions*

In addition to the SYNC signal, the software trigger and the RC compare trigger, an external trigger can be defined.

The TIOA or TIOB External Trigger Selection bit in CMRn (CMRn.ABETRG) selects TIOA or TIOB input signal as an external trigger. The External Trigger Edge Selection bit in CMRn (CMRn.ETREDG) defines the edge (rising, falling or both) detected to generate an external trigger. If CMRn.ETRGEDG is zero (none), the external trigger is disabled.

Figure 23-4. Capture Mode

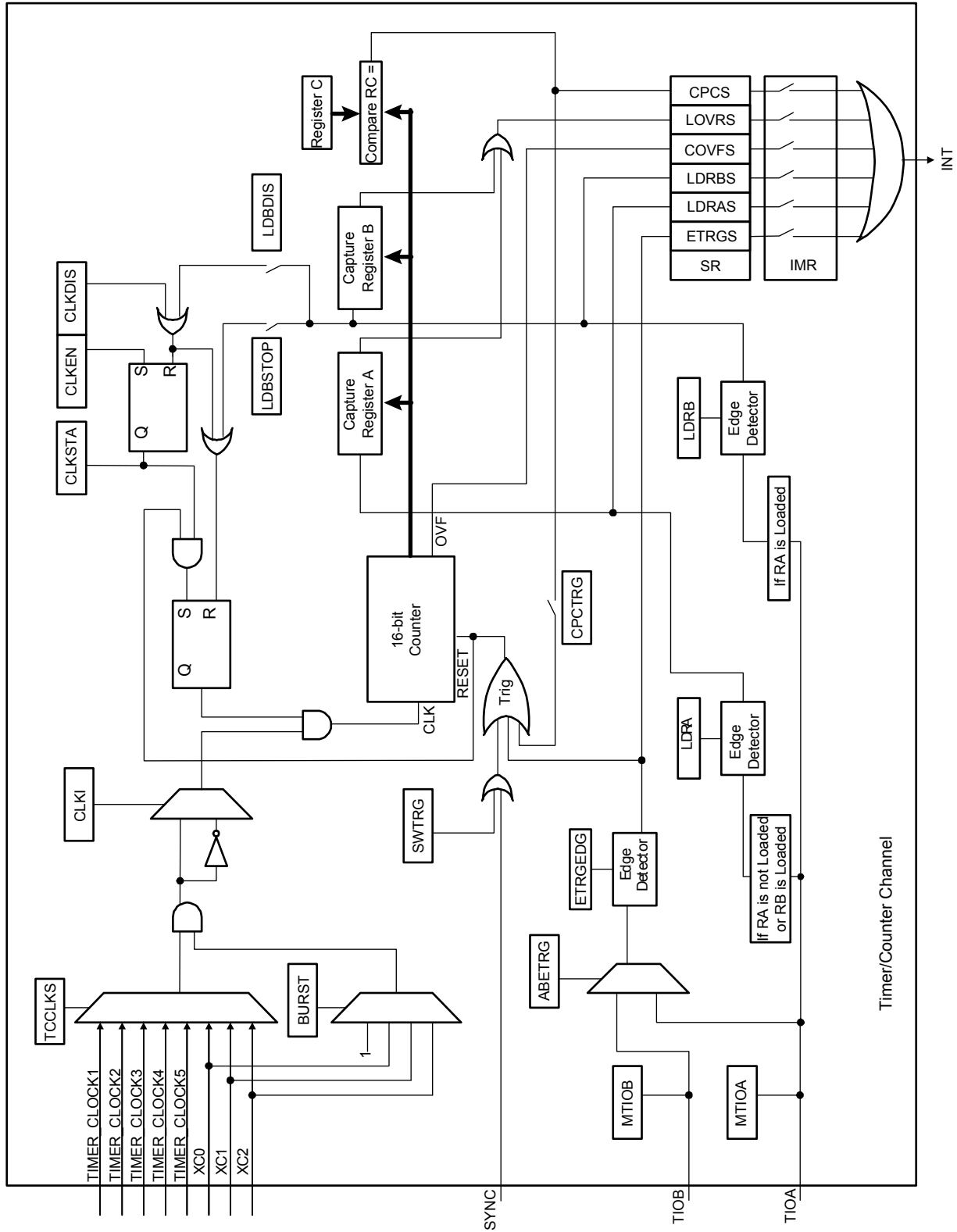

23.6.3 Waveform Operating Mode

Waveform operating mode is entered by writing a one to the CMRn.WAVE bit.

In Waveform operating mode the TC channel generates one or two PWM signals with the same frequency and independently programmable duty cycles, or generates different types of one-shot or repetitive pulses.

In this mode, TIOA is configured as an output and TIOB is defined as an output if it is not used as an external event.

[Figure 23-5 on page 481](#) shows the configuration of the TC channel when programmed in Waveform operating mode.

23.6.3.1 Waveform selection

Depending on the Waveform Selection field in CMRn (CMRn.WAVSEL), the behavior of CVn varies.

With any selection, RA, RB and RC can all be used as compare registers.

RA Compare is used to control the TIOA output, RB Compare is used to control the TIOB output (if correctly configured) and RC Compare is used to control TIOA and/or TIOB outputs.

Figure 23-5. Waveform Mode

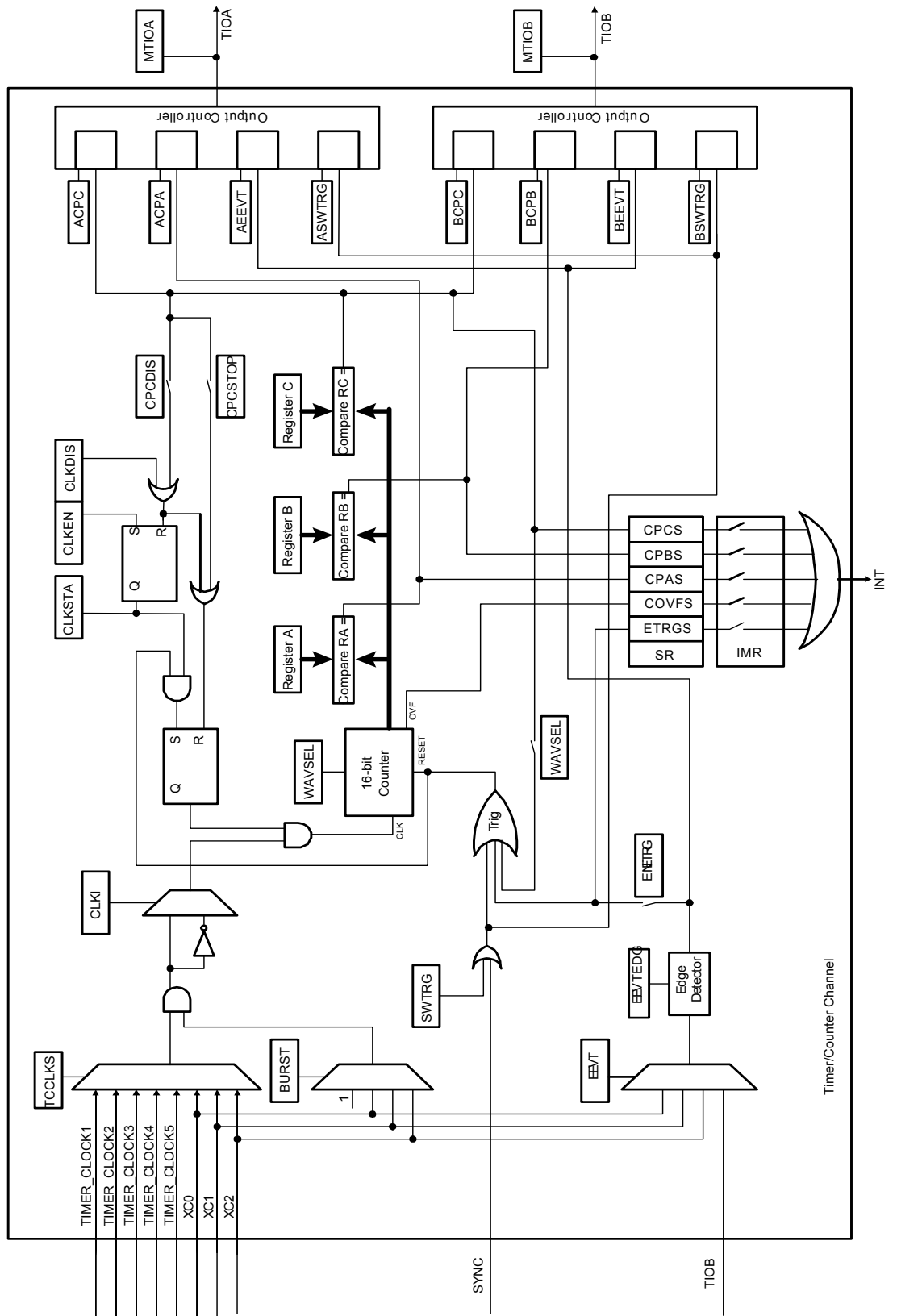

23.6.3.2 WAVSEL = 0

When CMRn.WAVSEL is zero, the value of CVn is incremented from 0 to 0xFFFF. Once 0xFFFF has been reached, the value of CVn is reset. Incrementation of CVn starts again and the cycle continues. See [Figure 23-6 on page 482](#).

An external event trigger or a software trigger can reset the value of CVn. It is important to note that the trigger may occur at any time. See [Figure 23-7 on page 483](#).

RC Compare cannot be programmed to generate a trigger in this configuration. At the same time, RC Compare can stop the counter clock (CMRn.CPCSTOP = 1) and/or disable the counter clock (CMRn.CPCDIS = 1).

Figure 23-6. WAVSEL= 0 Without Trigger

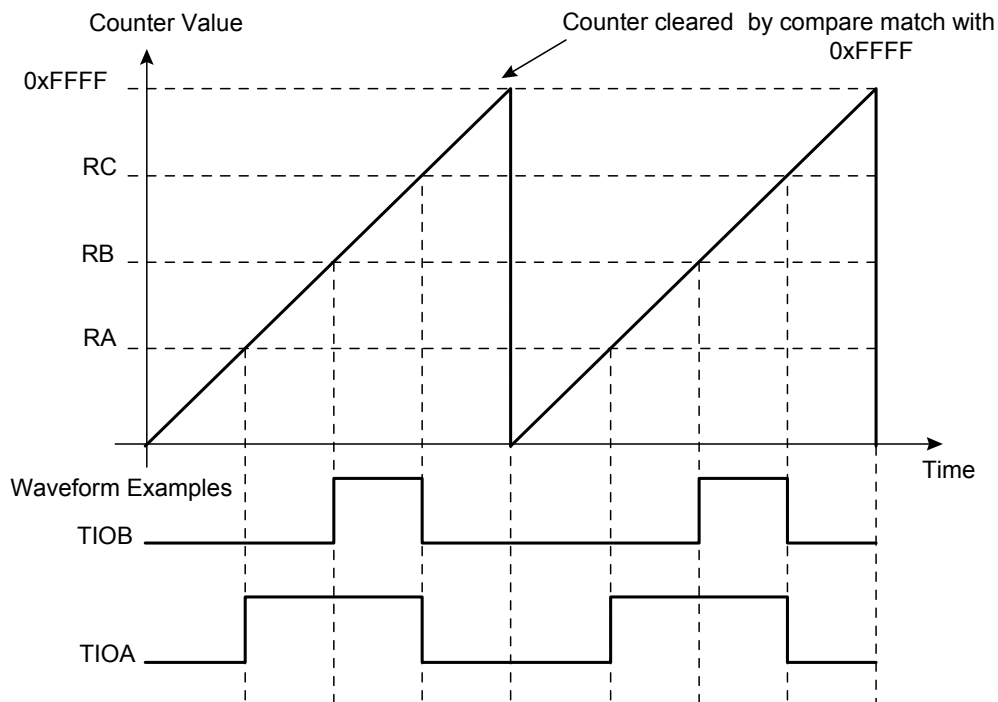
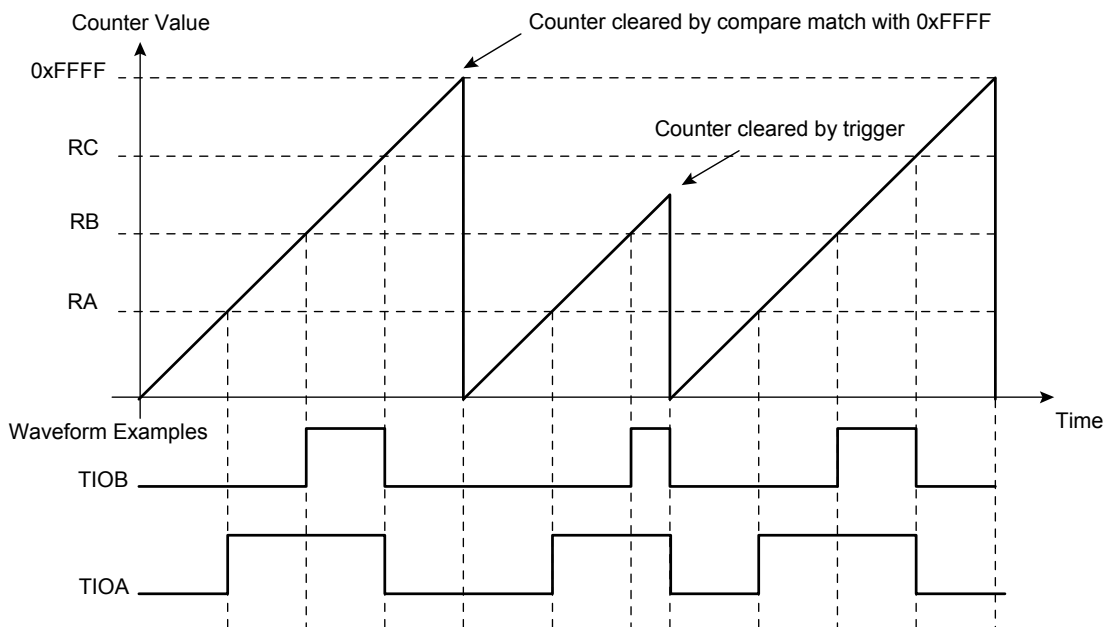

Figure 23-7. WAVSEL= 0 With Trigger

23.6.3.3 WAVSEL = 2

When $CMRn.WAVSEL$ is two, the value of CVn is incremented from zero to the value of RC , then automatically reset on a RC Compare. Once the value of CVn has been reset, it is then incremented and so on. See [Figure 23-8 on page 484](#).

It is important to note that CVn can be reset at any time by an external event or a software trigger if both are programmed correctly. See [Figure 23-9 on page 484](#).

In addition, RC Compare can stop the counter clock ($CMRn.CPCSTOP$) and/or disable the counter clock ($CMRn.CPCDIS = 1$).

Figure 23-8. WAVSEL = 2 Without Trigger

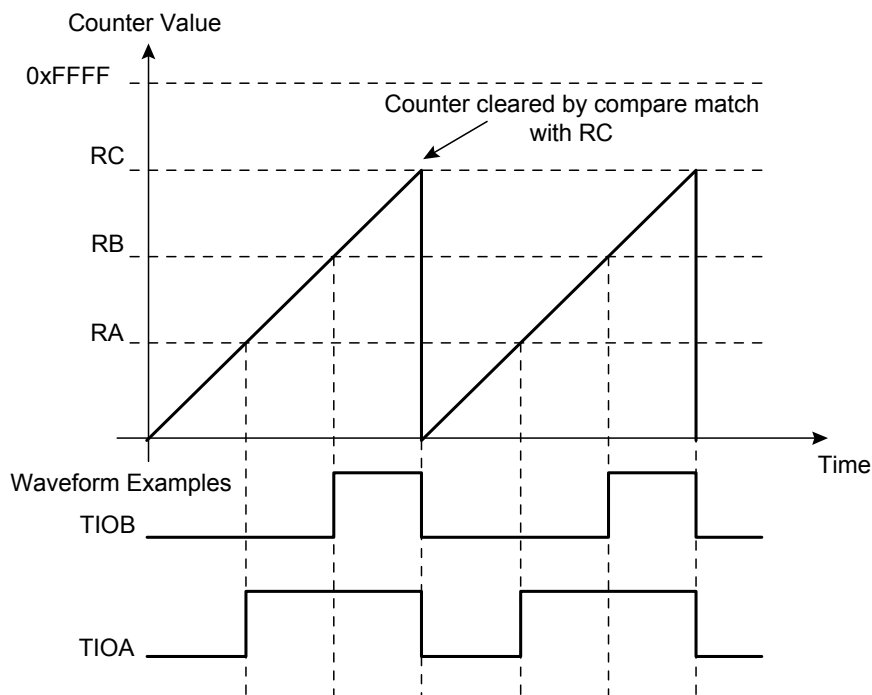
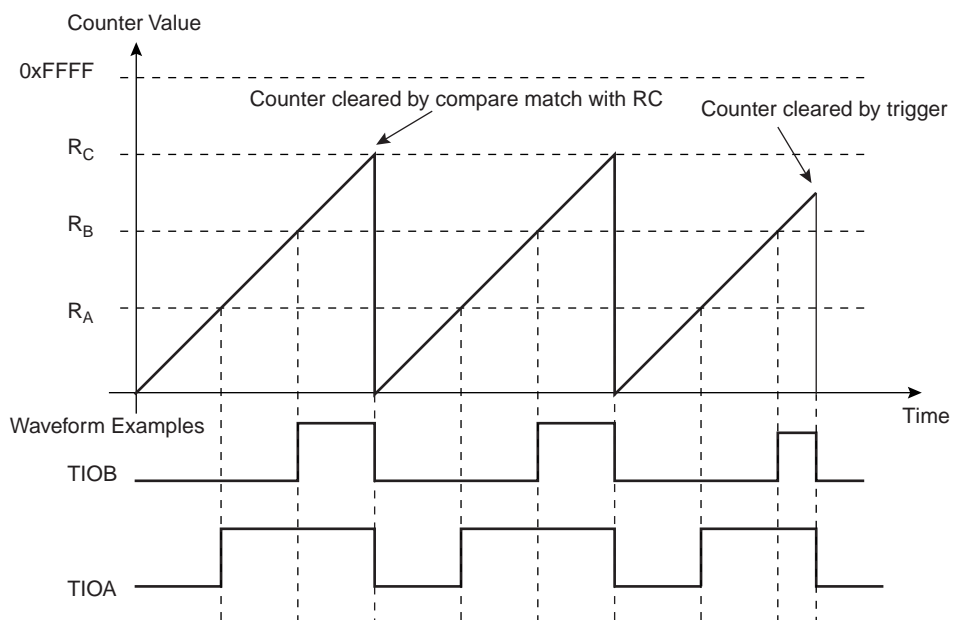

Figure 23-9. WAVSEL = 2 With Trigger



23.6.3.4 WAVSEL = 1

When CMRn.WAVSEL is one, the value of CVn is incremented from 0 to 0xFFFF. Once 0xFFFF is reached, the value of CVn is decremented to 0, then re-incremented to 0xFFFF and so on. See [Figure 23-10 on page 485](#).

A trigger such as an external event or a software trigger can modify CVn at any time. If a trigger occurs while CVn is incrementing, CVn then decrements. If a trigger is received while CVn is decrementing, CVn then increments. See [Figure 23-11 on page 485](#).

RC Compare cannot be programmed to generate a trigger in this configuration.

At the same time, RC Compare can stop the counter clock (CMRn.CPCSTOP = 1) and/or disable the counter clock (CMRn.CPCDIS = 1).

Figure 23-10. WAVSEL = 1 Without Trigger

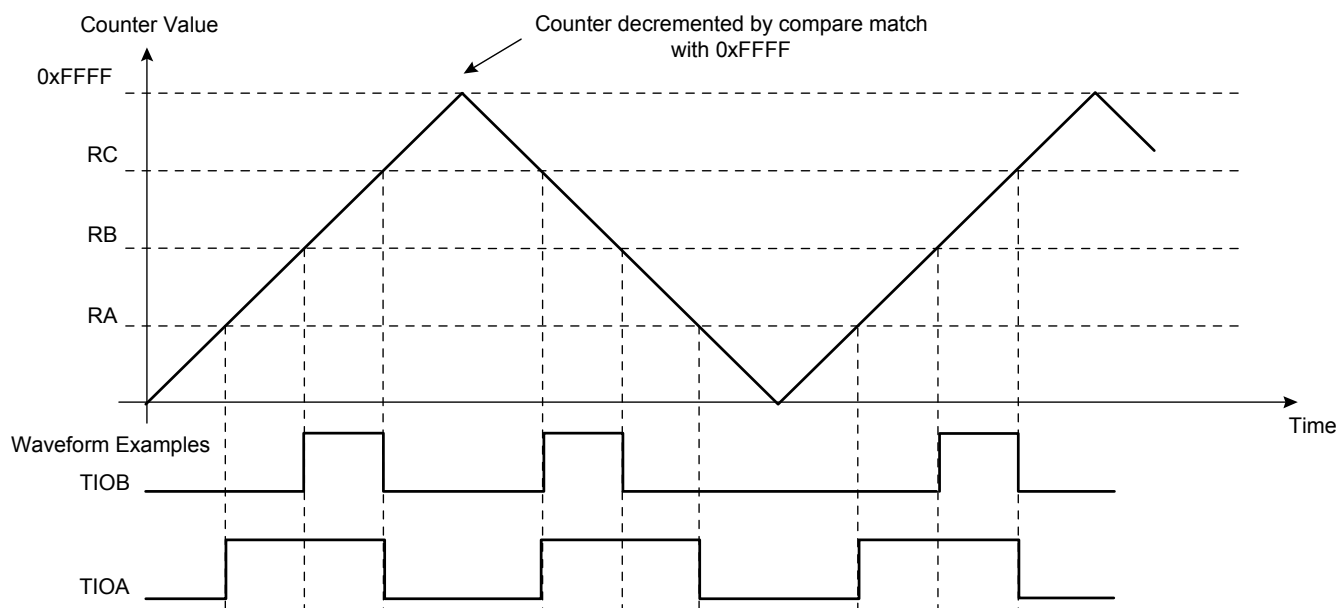
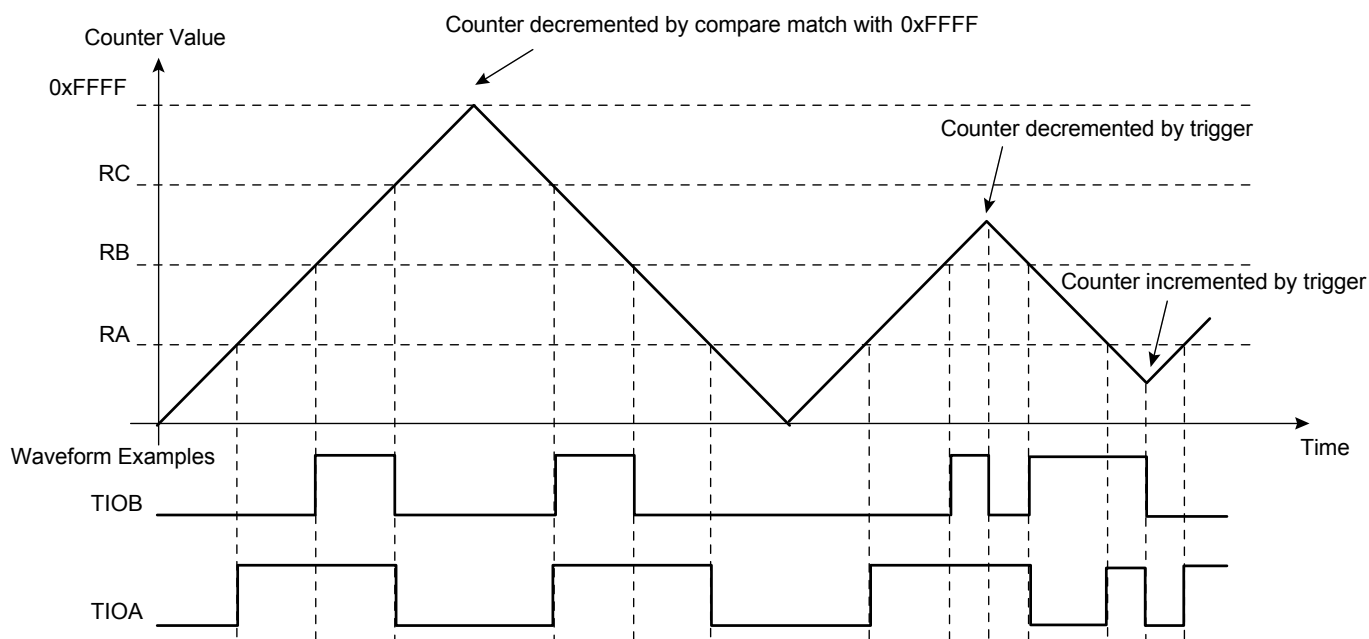

Figure 23-11. WAVSEL = 1 With Trigger



23.6.3.5 WAVSEL = 3

When $CMRn.WAVSEL$ is three, the value of CVn is incremented from zero to RC . Once RC is reached, the value of CVn is decremented to zero, then re-incremented to RC and so on. See [Figure 23-12 on page 486](#).

A trigger such as an external event or a software trigger can modify CVn at any time. If a trigger occurs while CVn is incrementing, CVn then decrements. If a trigger is received while CVn is decrementing, CVn then increments. See [Figure 23-13 on page 487](#).

RC Compare can stop the counter clock ($CMRn.CPCSTOP = 1$) and/or disable the counter clock ($CMRn.CPCDIS = 1$).

Figure 23-12. WAVSEL = 3 Without Trigger

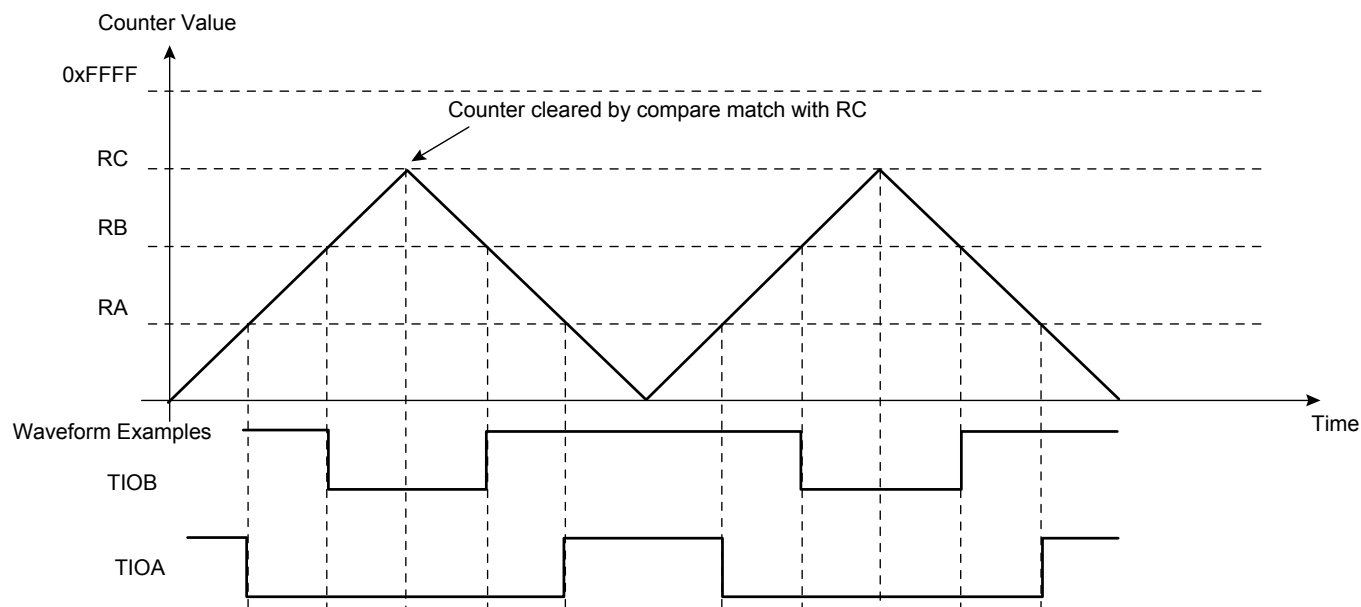
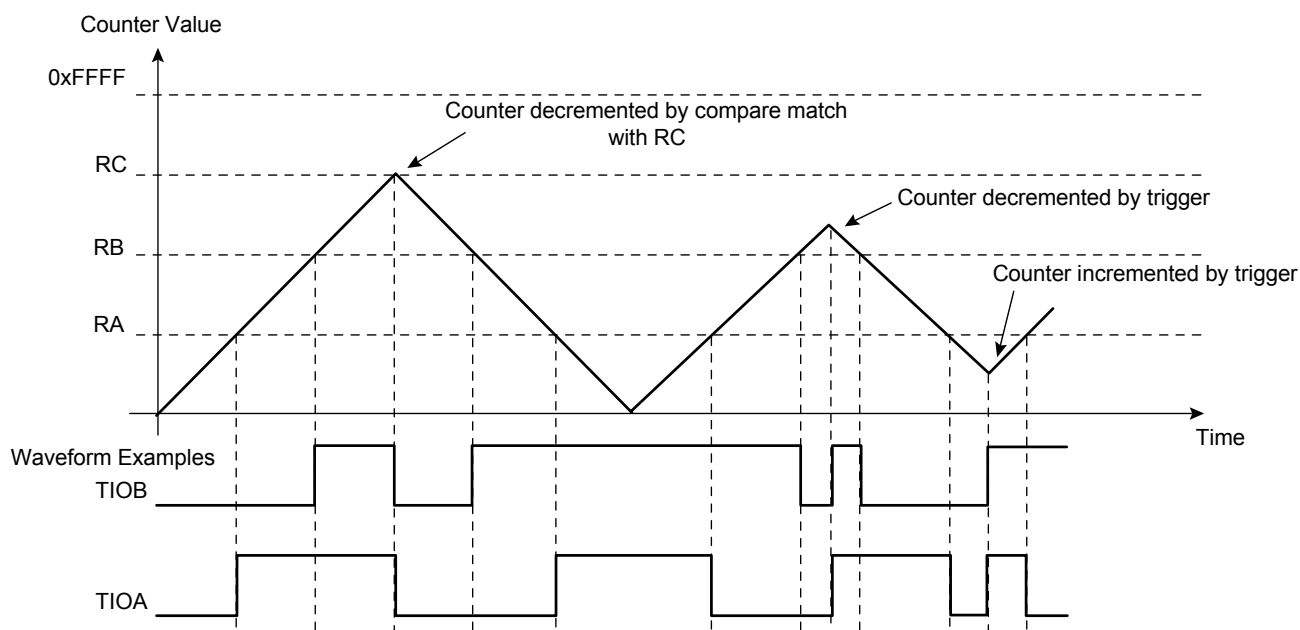

Figure 23-13. WAVSEL = 3 With Trigger



23.6.3.6 External event/trigger conditions

An external event can be programmed to be detected on one of the clock sources (XC0, XC1, XC2) or TIOB. The external event selected can then be used as a trigger.

The External Event Selection field in CMRn (CMRn.EEVT) selects the external trigger. The External Event Edge Selection field in CMRn (CMRn.EEVTEDG) defines the trigger edge for each of the possible external triggers (rising, falling or both). If CMRn.EEVTEDG is written to zero, no external event is defined.

If TIOB is defined as an external event signal (CMRn.EEVT = 0), TIOB is no longer used as an output and the compare register B is not used to generate waveforms and subsequently no IRQs. In this case the TC channel can only generate a waveform on TIOA.

When an external event is defined, it can be used as a trigger by writing a one to the CMRn.ENETRIG bit.

As in Capture mode, the SYNC signal and the software trigger are also available as triggers. RC Compare can also be used as a trigger depending on the CMRn.WAVSEL field.

23.6.3.7 Output controller

The output controller defines the output level changes on TIOA and TIOB following an event. TIOB control is used only if TIOB is defined as output (not as an external event).

The following events control TIOA and TIOB:

- software trigger
- external event
- RC compare

RA compare controls TIOA and RB compare controls TIOB. Each of these events can be programmed to set, clear or toggle the output as defined in the following fields in CMRn:

- RC Compare Effect on TIOB (CMRn.BCPC)

- RB Compare Effect on TIOB (CMRn.BCPB)
- RC Compare Effect on TIOA (CMRn.ACPC)
- RA Compare Effect on TIOA (CMRn.ACPA)

23.7 User Interface

Table 23-3. TC Register Memory Map

| Offset | Register | Register Name | Access | Reset |
|--------|--------------------------------------|---------------|---------------------------|------------|
| 0x00 | Channel 0 Control Register | CCR0 | Write-only | 0x00000000 |
| 0x04 | Channel 0 Mode Register | CMR0 | Read/Write | 0x00000000 |
| 0x10 | Channel 0 Counter Value | CV0 | Read-only | 0x00000000 |
| 0x14 | Channel 0 Register A | RA0 | Read/Write ⁽¹⁾ | 0x00000000 |
| 0x18 | Channel 0 Register B | RB0 | Read/Write ⁽¹⁾ | 0x00000000 |
| 0x1C | Channel 0 Register C | RC0 | Read/Write | 0x00000000 |
| 0x20 | Channel 0 Status Register | SR0 | Read-only | 0x00000000 |
| 0x24 | Interrupt Enable Register | IER0 | Write-only | 0x00000000 |
| 0x28 | Channel 0 Interrupt Disable Register | IDR0 | Write-only | 0x00000000 |
| 0x2C | Channel 0 Interrupt Mask Register | IMR0 | Read-only | 0x00000000 |
| 0x40 | Channel 1 Control Register | CCR1 | Write-only | 0x00000000 |
| 0x44 | Channel 1 Mode Register | CMR1 | Read/Write | 0x00000000 |
| 0x50 | Channel 1 Counter Value | CV1 | Read-only | 0x00000000 |
| 0x54 | Channel 1 Register A | RA1 | Read/Write ⁽¹⁾ | 0x00000000 |
| 0x58 | Channel 1 Register B | RB1 | Read/Write ⁽¹⁾ | 0x00000000 |
| 0x5C | Channel 1 Register C | RC1 | Read/Write | 0x00000000 |
| 0x60 | Channel 1 Status Register | SR1 | Read-only | 0x00000000 |
| 0x64 | Channel 1 Interrupt Enable Register | IER1 | Write-only | 0x00000000 |
| 0x68 | Channel 1 Interrupt Disable Register | IDR1 | Write-only | 0x00000000 |
| 0x6C | Channel 1 Interrupt Mask Register | IMR1 | Read-only | 0x00000000 |
| 0x80 | Channel 2 Control Register | CCR2 | Write-only | 0x00000000 |
| 0x84 | Channel 2 Mode Register | CMR2 | Read/Write | 0x00000000 |
| 0x90 | Channel 2 Counter Value | CV2 | Read-only | 0x00000000 |
| 0x94 | Channel 2 Register A | RA2 | Read/Write ⁽¹⁾ | 0x00000000 |
| 0x98 | Channel 2 Register B | RB2 | Read/Write ⁽¹⁾ | 0x00000000 |
| 0x9C | Channel 2 Register C | RC2 | Read/Write | 0x00000000 |
| 0xA0 | Channel 2 Status Register | SR2 | Read-only | 0x00000000 |
| 0xA4 | Channel 2 Interrupt Enable Register | IER2 | Write-only | 0x00000000 |
| 0xA8 | Channel 2 Interrupt Disable Register | IDR2 | Write-only | 0x00000000 |
| 0xAC | Channel 2 Interrupt Mask Register | IMR2 | Read-only | 0x00000000 |
| 0xC0 | Block Control Register | BCR | Write-only | 0x00000000 |
| 0xC4 | Block Mode Register | BMR | Read/Write | 0x00000000 |
| 0xF8 | Features Register | FEATURES | Read-only | _(2) |
| 0xFC | Version Register | VERSION | Read-only | _(2) |

- Notes:
1. Read-only if CMRn.WAVE is zero.
 2. The reset values are device specific. Please refer to the Module Configuration section at the end of this chapter.

23.7.1 Channel Control Register

Name: CCR
Access Type: Write-only
Offset: $0x00 + n * 0x40$
Reset Value: 0x00000000

| | | | | | | | |
|----|----|----|----|----|-------|--------|-------|
| 31 | 30 | 29 | 28 | 27 | 26 | 25 | 24 |
| - | - | - | - | - | - | - | - |
| 23 | 22 | 21 | 20 | 19 | 18 | 17 | 16 |
| - | - | - | - | - | - | - | - |
| 15 | 14 | 13 | 12 | 11 | 10 | 9 | 8 |
| - | - | - | - | - | - | - | - |
| 7 | 6 | 5 | 4 | 3 | 2 | 1 | 0 |
| - | - | - | - | - | SWTRG | CLKDIS | CLKEN |

- **SWTRG: Software Trigger Command**
 - 1: Writing a one to this bit will perform a software trigger: the counter is reset and the clock is started.
 - 0: Writing a zero to this bit has no effect.
- **CLKDIS: Counter Clock Disable Command**
 - 1: Writing a one to this bit will disable the clock.
 - 0: Writing a zero to this bit has no effect.
- **CLKEN: Counter Clock Enable Command**
 - 1: Writing a one to this bit will enable the clock if CLKDIS is not one.
 - 0: Writing a zero to this bit has no effect.

23.7.2 Channel Mode Register: Capture Mode

Name: CMR
Access Type: Read/Write
Offset: 0x04 + n * 0x40
Reset Value: 0x00000000

| | | | | | | | |
|--------|---------|-------|----|------|--------|---------|----|
| 31 | 30 | 29 | 28 | 27 | 26 | 25 | 24 |
| - | - | - | - | - | - | - | - |
| 23 | 22 | 21 | 20 | 19 | 18 | 17 | 16 |
| - | - | - | - | LDRB | | LDRA | |
| 15 | 14 | 13 | 12 | 11 | 10 | 9 | 8 |
| WAVE | CPCTRG | - | - | - | ABETRG | ETRGEDG | |
| 7 | 6 | 5 | 4 | 3 | 2 | 1 | 0 |
| LDBDIS | LDBSTOP | BURST | | CLKI | TCCLKS | | |

- LDRB: RB Loading Selection**

| LDRB | Edge |
|------|----------------------|
| 0 | none |
| 1 | rising edge of TIOA |
| 2 | falling edge of TIOA |
| 3 | each edge of TIOA |

- LDRA: RA Loading Selection**

| LDRA | Edge |
|------|----------------------|
| 0 | none |
| 1 | rising edge of TIOA |
| 2 | falling edge of TIOA |
| 3 | each edge of TIOA |

- WAVE**

1: Capture mode is disabled (Waveform mode is enabled).
0: Capture mode is enabled.

- CPCTRG: RC Compare Trigger Enable**

1: RC Compare resets the counter and starts the counter clock.
0: RC Compare has no effect on the counter and its clock.

- ABETRG: TIOA or TIOB External Trigger Selection**

1: TIOA is used as an external trigger.

0: TIOB is used as an external trigger.

- **ETRGEDG: External Trigger Edge Selection**

| ETRGEDG | Edge |
|---------|--------------|
| 0 | none |
| 1 | rising edge |
| 2 | falling edge |
| 3 | each edge |

- **LDBDIS: Counter Clock Disable with RB Loading**

1: Counter clock is disabled when RB loading occurs.

0: Counter clock is not disabled when RB loading occurs.

- **LDBSTOP: Counter Clock Stopped with RB Loading**

1: Counter clock is stopped when RB loading occurs.

0: Counter clock is not stopped when RB loading occurs.

- **BURST: Burst Signal Selection**

| BURST | Burst Signal Selection |
|-------|--|
| 0 | The clock is not gated by an external signal |
| 1 | XC0 is ANDed with the selected clock |
| 2 | XC1 is ANDed with the selected clock |
| 3 | XC2 is ANDed with the selected clock |

- **CLKI: Clock Invert**

1: The counter is incremented on falling edge of the clock.

0: The counter is incremented on rising edge of the clock.

- **TCCLKS: Clock Selection**

| TCCLKS | Clock Selected |
|--------|----------------|
| 0 | TIMER_CLOCK1 |
| 1 | TIMER_CLOCK2 |
| 2 | TIMER_CLOCK3 |
| 3 | TIMER_CLOCK4 |
| 4 | TIMER_CLOCK5 |
| 5 | XC0 |
| 6 | XC1 |
| 7 | XC2 |

23.7.3 Channel Mode Register: Waveform Mode

Name: CMR
Access Type: Read/Write
Offset: 0x04 + n * 0x40
Reset Value: 0x00000000

| | | | | | | | |
|--------|---------|-------|--------|------|--------|---------|----|
| 31 | 30 | 29 | 28 | 27 | 26 | 25 | 24 |
| BSWTRG | | BEEVT | | BCPC | | BCPB | |
| 23 | 22 | 21 | 20 | 19 | 18 | 17 | 16 |
| ASWTRG | | AEEVT | | ACPC | | ACPA | |
| 15 | 14 | 13 | 12 | 11 | 10 | 9 | 8 |
| WAVE | WAVSEL | | ENETRГ | EEVT | | EEVTEDG | |
| 7 | 6 | 5 | 4 | 3 | 2 | 1 | 0 |
| CPCDIS | CPCSTOP | BURST | | CLKI | TCCLKS | | |

- BSWTRG: Software Trigger Effect on TIOB**

| BSWTRG | Effect |
|--------|--------|
| 0 | none |
| 1 | set |
| 2 | clear |
| 3 | toggle |

- BEEVT: External Event Effect on TIOB**

| BEEVT | Effect |
|-------|--------|
| 0 | none |
| 1 | set |
| 2 | clear |
| 3 | toggle |

- **BCPC: RC Compare Effect on TIOB**

| BCPC | Effect |
|------|--------|
| 0 | none |
| 1 | set |
| 2 | clear |
| 3 | toggle |

- **BCPB: RB Compare Effect on TIOB**

| BCPB | Effect |
|------|--------|
| 0 | none |
| 1 | set |
| 2 | clear |
| 3 | toggle |

- **ASWTRG: Software Trigger Effect on TIOA**

| ASWTRG | Effect |
|--------|--------|
| 0 | none |
| 1 | set |
| 2 | clear |
| 3 | toggle |

- **AAEVT: External Event Effect on TIOA**

| AAEVT | Effect |
|-------|--------|
| 0 | none |
| 1 | set |
| 2 | clear |
| 3 | toggle |

- **ACPC: RC Compare Effect on TIOA**

| ACPC | Effect |
|------|--------|
| 0 | none |
| 1 | set |
| 2 | clear |
| 3 | toggle |

- **ACPA: RA Compare Effect on TIOA**

| ACPA | Effect |
|------|--------|
| 0 | none |
| 1 | set |
| 2 | clear |
| 3 | toggle |

- **WAVE**

1: Waveform mode is enabled.

0: Waveform mode is disabled (Capture mode is enabled).

- **WAVSEL: Waveform Selection**

| WAVSEL | Effect |
|--------|---|
| 0 | UP mode without automatic trigger on RC Compare |
| 1 | UPDOWN mode without automatic trigger on RC Compare |
| 2 | UP mode with automatic trigger on RC Compare |
| 3 | UPDOWN mode with automatic trigger on RC Compare |

- **ENETRГ: External Event Trigger Enable**

1: The external event resets the counter and starts the counter clock.

0: The external event has no effect on the counter and its clock. In this case, the selected external event only controls the TIOA output.

- **EEVT: External Event Selection**

| EEVT | Signal selected as external event | TIOB Direction |
|------|-----------------------------------|----------------------|
| 0 | TIOB | input ⁽¹⁾ |
| 1 | XC0 | output |
| 2 | XC1 | output |
| 3 | XC2 | output |

Note: 1. If TIOB is chosen as the external event signal, it is configured as an input and no longer generates waveforms and subsequently no IRQs.

- **EEVTEDG: External Event Edge Selection**

| EEVTEDG | Edge |
|---------|--------------|
| 0 | none |
| 1 | rising edge |
| 2 | falling edge |
| 3 | each edge |

- **CPCDIS: Counter Clock Disable with RC Compare**

1: Counter clock is disabled when counter reaches RC.

0: Counter clock is not disabled when counter reaches RC.

- **CPCSTOP: Counter Clock Stopped with RC Compare**

1: Counter clock is stopped when counter reaches RC.

0: Counter clock is not stopped when counter reaches RC.

- **BURST: Burst Signal Selection**

| BURST | Burst Signal Selection |
|-------|---|
| 0 | The clock is not gated by an external signal. |
| 1 | XC0 is ANDed with the selected clock. |
| 2 | XC1 is ANDed with the selected clock. |
| 3 | XC2 is ANDed with the selected clock. |

- **CLKI: Clock Invert**

1: Counter is incremented on falling edge of the clock.

0: Counter is incremented on rising edge of the clock.

- **TCCLKS: Clock Selection**

| TCCLKS | Clock Selected |
|--------|----------------|
| 0 | TIMER_CLOCK1 |
| 1 | TIMER_CLOCK2 |
| 2 | TIMER_CLOCK3 |
| 3 | TIMER_CLOCK4 |
| 4 | TIMER_CLOCK5 |
| 5 | XC0 |
| 6 | XC1 |
| 7 | XC2 |

23.7.4 Channel Counter Value Register

Name: CV
Access Type: Read-only
Offset: $0x10 + n * 0x40$
Reset Value: 0x00000000

| | | | | | | | |
|----------|----|----|----|----|----|----|----|
| 31 | 30 | 29 | 28 | 27 | 26 | 25 | 24 |
| - | - | - | - | - | - | - | - |
| 23 | 22 | 21 | 20 | 19 | 18 | 17 | 16 |
| - | - | - | - | - | - | - | - |
| 15 | 14 | 13 | 12 | 11 | 10 | 9 | 8 |
| CV[15:8] | | | | | | | |
| 7 | 6 | 5 | 4 | 3 | 2 | 1 | 0 |
| CV[7:0] | | | | | | | |

- CV: Counter Value**
 CV contains the counter value in real time.

23.7.5 Channel Register A

Name: RA

Access Type: Read-only if CMRn.WAVE = 0, Read/Write if CMRn.WAVE = 1

Offset: 0x14 + n * 0x40

Reset Value: 0x00000000

| | | | | | | | |
|----------|----|----|----|----|----|----|----|
| 31 | 30 | 29 | 28 | 27 | 26 | 25 | 24 |
| - | - | - | - | - | - | - | - |
| 23 | 22 | 21 | 20 | 19 | 18 | 17 | 16 |
| - | - | - | - | - | - | - | - |
| 15 | 14 | 13 | 12 | 11 | 10 | 9 | 8 |
| RA[15:8] | | | | | | | |
| 7 | 6 | 5 | 4 | 3 | 2 | 1 | 0 |
| RA[7:0] | | | | | | | |

- **RA: Register A**

RA contains the Register A value in real time.

23.7.6 Channel Register B

Name: RB

Access Type: Read-only if CMRn.WAVE = 0, Read/Write if CMRn.WAVE = 1

Offset: 0x18 + n * 0x40

Reset Value: 0x00000000

| | | | | | | | |
|----------|----|----|----|----|----|----|----|
| 31 | 30 | 29 | 28 | 27 | 26 | 25 | 24 |
| - | - | - | - | - | - | - | - |
| 23 | 22 | 21 | 20 | 19 | 18 | 17 | 16 |
| - | - | - | - | - | - | - | - |
| 15 | 14 | 13 | 12 | 11 | 10 | 9 | 8 |
| RB[15:8] | | | | | | | |
| 7 | 6 | 5 | 4 | 3 | 2 | 1 | 0 |
| RB[7:0] | | | | | | | |

- **RB: Register B**

RB contains the Register B value in real time.

23.7.7 Channel Register C

Name: RC
Access Type: Read/Write
Offset: $0x1C + n * 0x40$
Reset Value: 0x00000000

| | | | | | | | |
|----------|----|----|----|----|----|----|----|
| 31 | 30 | 29 | 28 | 27 | 26 | 25 | 24 |
| - | - | - | - | - | - | - | - |
| 23 | 22 | 21 | 20 | 19 | 18 | 17 | 16 |
| - | - | - | - | - | - | - | - |
| 15 | 14 | 13 | 12 | 11 | 10 | 9 | 8 |
| RC[15:8] | | | | | | | |
| 7 | 6 | 5 | 4 | 3 | 2 | 1 | 0 |
| RC[7:0] | | | | | | | |

- RC: Register C**
 RC contains the Register C value in real time.

23.7.8 Channel Status Register

Name: SR
Access Type: Read-only
Offset: 0x20 + n * 0x40
Reset Value: 0x00000000

| | | | | | | | |
|-------|-------|-------|------|------|-------|-------|--------|
| 31 | 30 | 29 | 28 | 27 | 26 | 25 | 24 |
| - | - | - | - | - | - | - | - |
| 23 | 22 | 21 | 20 | 19 | 18 | 17 | 16 |
| - | - | - | - | - | MTIOB | MTIOA | CLKSTA |
| 15 | 14 | 13 | 12 | 11 | 10 | 9 | 8 |
| - | - | - | - | - | - | - | - |
| 7 | 6 | 5 | 4 | 3 | 2 | 1 | 0 |
| ETRGS | LDRBS | LDRAS | CPCS | CPBS | CPAS | LOVRS | COVFS |

Note: Reading the Status Register will also clear the interrupt bit for the corresponding interrupts.

- **MTIOB: TIOB Mirror**
 - 1: TIOB is high. If CMRn.WAVE is zero, this means that TIOB pin is high. If CMRn.WAVE is one, this means that TIOB is driven high.
 - 0: TIOB is low. If CMRn.WAVE is zero, this means that TIOB pin is low. If CMRn.WAVE is one, this means that TIOB is driven low.
- **MTIOA: TIOA Mirror**
 - 1: TIOA is high. If CMRn.WAVE is zero, this means that TIOA pin is high. If CMRn.WAVE is one, this means that TIOA is driven high.
 - 0: TIOA is low. If CMRn.WAVE is zero, this means that TIOA pin is low. If CMRn.WAVE is one, this means that TIOA is driven low.
- **CLKSTA: Clock Enabling Status**
 - 1: This bit is set when the clock is enabled.
 - 0: This bit is cleared when the clock is disabled.
- **ETRGS: External Trigger Status**
 - 1: This bit is set when an external trigger has occurred.
 - 0: This bit is cleared when the SR register is read.
- **LDRBS: RB Loading Status**
 - 1: This bit is set when an RB Load has occurred and CMRn.WAVE is zero.
 - 0: This bit is cleared when the SR register is read.
- **LDRAS: RA Loading Status**
 - 1: This bit is set when an RA Load has occurred and CMRn.WAVE is zero.
 - 0: This bit is cleared when the SR register is read.
- **CPCS: RC Compare Status**
 - 1: This bit is set when an RC Compare has occurred.
 - 0: This bit is cleared when the SR register is read.

- **CPBS: RB Compare Status**
 - 1: This bit is set when an RB Compare has occurred and CMRn.WAVE is one.
 - 0: This bit is cleared when the SR register is read.
- **CPAS: RA Compare Status**
 - 1: This bit is set when an RA Compare has occurred and CMRn.WAVE is one.
 - 0: This bit is cleared when the SR register is read.
- **LOVRS: Load Overrun Status**
 - 1: This bit is set when RA or RB have been loaded at least twice without any read of the corresponding register and CMRn.WAVE is zero.
 - 0: This bit is cleared when the SR register is read.
- **COVFS: Counter Overflow Status**
 - 1: This bit is set when a counter overflow has occurred.
 - 0: This bit is cleared when the SR register is read.

23.7.9 Channel Interrupt Enable Register

Name: IER
Access Type: Write-only
Offset: $0x24 + n * 0x40$
Reset Value: 0x00000000

| | | | | | | | |
|-------|-------|-------|------|------|------|-------|-------|
| 31 | 30 | 29 | 28 | 27 | 26 | 25 | 24 |
| - | - | - | - | - | - | - | - |
| 23 | 22 | 21 | 20 | 19 | 18 | 17 | 16 |
| - | - | - | - | - | - | - | - |
| 15 | 14 | 13 | 12 | 11 | 10 | 9 | 8 |
| - | - | - | - | - | - | - | - |
| 7 | 6 | 5 | 4 | 3 | 2 | 1 | 0 |
| ETRGS | LDRBS | LDRAS | CPCS | CPBS | CPAS | LOVRS | COVFS |

Writing a zero to a bit in this register has no effect.

Writing a one to a bit in this register will set the corresponding bit in IMR.

23.7.10 Channel Interrupt Disable Register

Name: IDR
Access Type: Write-only
Offset: $0x28 + n * 0x40$
Reset Value: 0x00000000

| | | | | | | | |
|-------|-------|-------|------|------|------|-------|-------|
| 31 | 30 | 29 | 28 | 27 | 26 | 25 | 24 |
| - | - | - | - | - | - | - | - |
| 23 | 22 | 21 | 20 | 19 | 18 | 17 | 16 |
| - | - | - | - | - | - | - | - |
| 15 | 14 | 13 | 12 | 11 | 10 | 9 | 8 |
| - | - | - | - | - | - | - | - |
| 7 | 6 | 5 | 4 | 3 | 2 | 1 | 0 |
| ETRGS | LDRBS | LDRAS | CPCS | CPBS | CPAS | LOVRS | COVFS |

Writing a zero to a bit in this register has no effect.

Writing a one to a bit in this register will clear the corresponding bit in IMR.

23.7.11 Channel Interrupt Mask Register

Name: IMR
Access Type: Read-only
Offset: $0x2C + n * 0x40$
Reset Value: 0x00000000

| | | | | | | | |
|-------|-------|-------|------|------|------|-------|-------|
| 31 | 30 | 29 | 28 | 27 | 26 | 25 | 24 |
| - | - | - | - | - | - | - | - |
| 23 | 22 | 21 | 20 | 19 | 18 | 17 | 16 |
| - | - | - | - | - | - | - | - |
| 15 | 14 | 13 | 12 | 11 | 10 | 9 | 8 |
| - | - | - | - | - | - | - | - |
| 7 | 6 | 5 | 4 | 3 | 2 | 1 | 0 |
| ETRGS | LDRBS | LDRAS | CPCS | CPBS | CPAS | LOVRS | COVFS |

0: The corresponding interrupt is disabled.

1: The corresponding interrupt is enabled.

A bit in this register is cleared when the corresponding bit in IDR is written to one.

A bit in this register is set when the corresponding bit in IER is written to one.

23.7.12 Block Control Register

Name: BCR
Access Type: Write-only
Offset: 0xC0
Reset Value: 0x00000000

| | | | | | | | |
|----|----|----|----|----|----|----|------|
| 31 | 30 | 29 | 28 | 27 | 26 | 25 | 24 |
| - | - | - | - | - | - | - | - |
| 23 | 22 | 21 | 20 | 19 | 18 | 17 | 16 |
| - | - | - | - | - | - | - | - |
| 15 | 14 | 13 | 12 | 11 | 10 | 9 | 8 |
| - | - | - | - | - | - | - | - |
| 7 | 6 | 5 | 4 | 3 | 2 | 1 | 0 |
| - | - | - | - | - | - | - | SYNC |

- **SYNC: Synchro Command**

- 1: Writing a one to this bit asserts the SYNC signal which generates a software trigger simultaneously for each of the channels.
- 0: Writing a zero to this bit has no effect.

23.7.13 Block Mode Register

Name: BMR
Access Type: Read/Write
Offset: 0xC4
Reset Value: 0x00000000

| | | | | | | | |
|----|----|---------|----|---------|----|---------|----|
| 31 | 30 | 29 | 28 | 27 | 26 | 25 | 24 |
| - | - | - | - | - | - | - | - |
| 23 | 22 | 21 | 20 | 19 | 18 | 17 | 16 |
| - | - | - | - | - | - | - | - |
| 15 | 14 | 13 | 12 | 11 | 10 | 9 | 8 |
| - | - | - | - | - | - | - | - |
| 7 | 6 | 5 | 4 | 3 | 2 | 1 | 0 |
| - | - | TC2XC2S | | TC1XC1S | | TC0XC0S | |

- **TC2XC2S: External Clock Signal 2 Selection**

| TC2XC2S | Signal Connected to XC2 |
|---------|-------------------------|
| 0 | TCLK2 |
| 1 | none |
| 2 | TIOA0 |
| 3 | TIOA1 |

- **TC1XC1S: External Clock Signal 1 Selection**

| TC1XC1S | Signal Connected to XC1 |
|---------|-------------------------|
| 0 | TCLK1 |
| 1 | none |
| 2 | TIOA0 |
| 3 | TIOA2 |

- TC0XC0S: External Clock Signal 0 Selection

| TC0XC0S | Signal Connected to XC0 |
|---------|-------------------------|
| 0 | TCLK0 |
| 1 | none |
| 2 | TIOA1 |
| 3 | TIOA2 |

23.7.14 Features Register

Name: FEATURES

Access Type: Read-only

Offset: 0xF8

Reset Value: -

| | | | | | | | |
|---------|----|----|----|----|----|---------|----------|
| 31 | 30 | 29 | 28 | 27 | 26 | 25 | 24 |
| - | - | - | - | - | - | - | - |
| 23 | 22 | 21 | 20 | 19 | 18 | 17 | 16 |
| - | - | - | - | - | - | - | |
| 15 | 14 | 13 | 12 | 11 | 10 | 9 | 8 |
| - | - | - | - | - | - | BRPBHSB | UPDNIMPL |
| 7 | 6 | 5 | 4 | 3 | 2 | 1 | 0 |
| CTRSIZE | | | | | | | |

- **BRPBHSB: Bridge type is PB to HSB**
 1: Bridge type is PB to HSB.
 0: Bridge type is not PB to HSB.
- **UPDNIMPL: Up/down is implemented**
 1: Up/down counter capability is implemented.
 0: Up/down counter capability is not implemented.
- **CTRSIZE: Counter size**
 This field indicates the size of the counter in bits.

23.7.15 Version Register

Name: VERSION

Access Type: Read-only

Offset: 0xFC

Reset Value: -

| | | | | | | | |
|--------------|----|----|----|---------------|----|----|----|
| 31 | 30 | 29 | 28 | 27 | 26 | 25 | 24 |
| - | - | - | - | - | - | - | - |
| 23 | 22 | 21 | 20 | 19 | 18 | 17 | 16 |
| - | - | - | - | VARIANT | | | |
| 15 | 14 | 13 | 12 | 11 | 10 | 9 | 8 |
| - | - | - | - | VERSION[11:8] | | | |
| 7 | 6 | 5 | 4 | 3 | 2 | 1 | 0 |
| VERSION[7:0] | | | | | | | |

- **VARIANT: Variant number**
Reserved. No functionality associated.
- **VERSION: Version number**
Version number of the module. No functionality associated.

23.8 Module Configuration

The specific configuration for each TC instance is listed in the following tables. The module bus clocks listed here are connected to the system bus clocks according to the table in the Power Manager section.

Table 23-4. Module Clock Name

| Module name | Clock name |
|-------------|------------|
| TC0 | CLK_TC0 |

23.8.1 Clock Connections

Each Timer/Counter channel can independently select an internal or external clock source for its counter:

Table 23-5. Timer/Counter clock connections

| Source | Name | Connection |
|----------|--------------|-------------------|
| Internal | TIMER_CLOCK1 | 32 KHz Oscillator |
| | TIMER_CLOCK2 | PBA Clock / 2 |
| | TIMER_CLOCK3 | PBA Clock / 8 |
| | TIMER_CLOCK4 | PBA Clock / 32 |
| | TIMER_CLOCK5 | PBA Clock / 128 |

24. Pulse Width Modulation Controller (PWM)

Rev: 1.3.0.1

24.1 Features

- **7 Channels**
- **One 20-bit Counter Per Channel**
- **Common Clock Generator Providing Thirteen Different Clocks**
 - **A Modulo n Counter Providing Eleven Clocks**
 - **Two Independent Linear Dividers Working on Modulo n Counter Outputs**
- **Independent Channels**
 - **Independent Enable Disable Command for Each Channel**
 - **Independent Clock Selection for Each Channel**
 - **Independent Period and Duty Cycle for Each Channel**
 - **Double Buffering of Period or Duty Cycle for Each Channel**
 - **Programmable Selection of The Output Waveform Polarity for Each Channel**
 - **Programmable Center or Left Aligned Output Waveform for Each Channel**

24.2 Description

The PWM macrocell controls several channels independently. Each channel controls one square output waveform. Characteristics of the output waveform such as period, duty-cycle and polarity are configurable through the user interface. Each channel selects and uses one of the clocks provided by the clock generator. The clock generator provides several clocks resulting from the division of the PWM macrocell master clock.

All PWM macrocell accesses are made through registers mapped on the peripheral bus.

Channels can be synchronized, to generate non overlapped waveforms. All channels integrate a double buffering system in order to prevent an unexpected output waveform while modifying the period or the duty-cycle.

24.3 Block Diagram

Figure 24-1. Pulse Width Modulation Controller Block Diagram

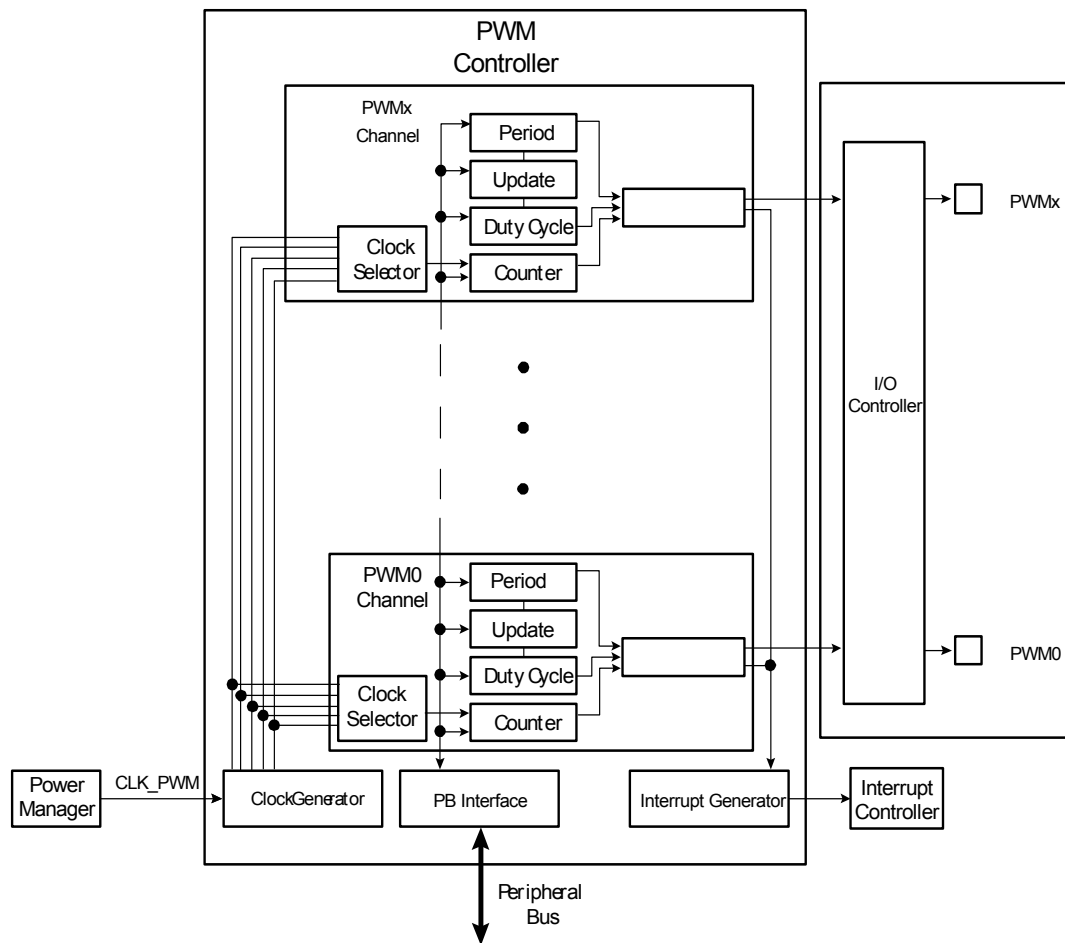

24.4 I/O Lines Description

Each channel outputs one waveform on one external I/O line.

Table 24-1. I/O Line Description

| Name | Description | Type |
|------|-----------------------------------|--------|
| PWMx | PWM Waveform Output for channel x | Output |

24.5 Product Dependencies

24.5.1 I/O Lines

The pins used for interfacing the PWM may be multiplexed with I/O controller lines. The programmer must first program the I/O controller to assign the desired PWM pins to their peripheral function. If I/O lines of the PWM are not used by the application, they can be used for other purposes by the I/O controller.

Not all PWM outputs may be enabled. If an application requires only four channels, then only four I/O lines will be assigned to PWM outputs.

24.5.2 Debug operation

The PWM clock is running during debug operation.

24.5.3 Power Manager

The PWM clock is generated by the Power Manager. Before using the PWM, the user must ensure that the PWM clock is enabled in the Power Manager. However, if the application does not require PWM operations, the PWM clock can be stopped when not needed and be restarted later. In this case, the PWM will resume its operations where it left off.

In the PWM description, CLK_PWM is the clock of the peripheral bus to which the PWM is connected.

24.5.4 Interrupts

The PWM interrupt line is connected to the interrupt controller. Using the PWM interrupt requires the interrupt controller to be programmed first.

24.6 Functional Description

The PWM macrocell is primarily composed of a clock generator module and 7 channels.

- Clocked by the system clock, CLK_PWM, the clock generator module provides 13 clocks.
- Each channel can independently choose one of the clock generator outputs.
- Each channel generates an output waveform with attributes that can be defined independently for each channel through the user interface registers.

24.6.1 PWM Clock Generator

Figure 24-2. Functional View of the Clock Generator Block Diagram

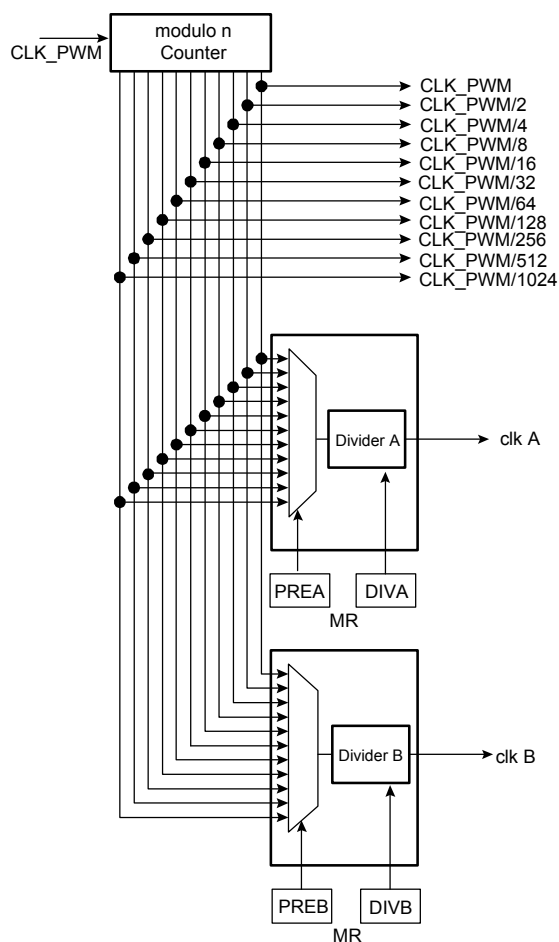

Caution: Before using the PWM macrocell, the programmer must ensure that the PWM clock in the Power Manager is enabled.

The PWM macrocell master clock, CLK_PWM, is divided in the clock generator module to provide different clocks available for all channels. Each channel can independently select one of the

divided clocks.

The clock generator is divided in three blocks:

- a modulo n counter which provides 11 clocks: F_{CLK_PWM} , $F_{CLK_PWM}/2$, $F_{CLK_PWM}/4$, $F_{CLK_PWM}/8$, $F_{CLK_PWM}/16$, $F_{CLK_PWM}/32$, $F_{CLK_PWM}/64$, $F_{CLK_PWM}/128$, $F_{CLK_PWM}/256$, $F_{CLK_PWM}/512$, $F_{CLK_PWM}/1024$
- two linear dividers (1, 1/2, 1/3, ... 1/255) that provide two separate clocks: clkA and clkB

Each linear divider can independently divide one of the clocks of the modulo n counter. The selection of the clock to be divided is made according to the PREA (PREB) field of the Mode register (MR). The resulting clock clkA (clkB) is the clock selected divided by DIVA (DIVB) field value in the Mode register (MR).

After a reset of the PWM controller, DIVA (DIVB) and PREA (PREB) in the Mode register are cleared. This implies that after reset clkA (clkB) are turned off.

At reset, all clocks provided by the modulo n counter are turned off except clock “clk”. This situation is also true when the PWM master clock is turned off through the Power Manager .

24.6.2 PWM Channel

24.6.2.1 Block Diagram

Figure 24-3. Functional View of the Channel Block Diagram

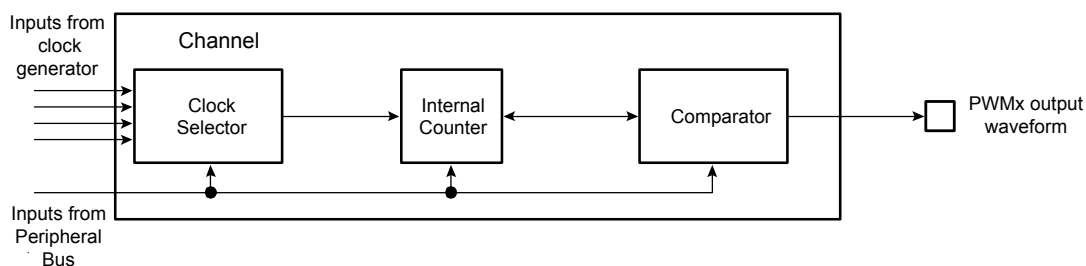

Each of the 7 channels is composed of three blocks:

- A clock selector which selects one of the clocks provided by the clock generator described in [Section 24.6.1](#).
- An internal counter clocked by the output of the clock selector. This internal counter is incremented or decremented according to the channel configuration and comparators events. The size of the internal counter is 20 bits.
- A comparator used to generate events according to the internal counter value. It also computes the PWMx output waveform according to the configuration.

24.6.2.2 Waveform Properties

The different properties of output waveforms are:

- the **internal clock selection**. The internal channel counter is clocked by one of the clocks provided by the clock generator described in the previous section. This channel parameter is defined in the CPRE field of the CMRx register. This field is reset at 0.

- the **waveform period**. This channel parameter is defined in the CPRD field of the CPRDx register.

- If the waveform is left aligned, then the output waveform period depends on the counter source clock and can be calculated:

By using the Master Clock (CLK_PWM) divided by an X given prescaler value (with X being 1, 2, 4, 8, 16, 32, 64, 128, 256, 512, or 1024), the resulting period formula will be:

$$\frac{(X \times CPRD)}{CLK_PWM}$$

By using a Master Clock divided by one of both DIVA or DIVB divider, the formula becomes, respectively:

$$\frac{(CPRD \times DIVA)}{CLK_PWM} \text{ or } \frac{(CPRD \times DIVB)}{CLK_PWM}$$

If the waveform is center aligned then the output waveform period depends on the counter source clock and can be calculated:

By using the Master Clock (CLK_PWM) divided by an X given prescaler value (with X being 1, 2, 4, 8, 16, 32, 64, 128, 256, 512, or 1024). The resulting period formula will be:

$$\frac{(2 \times X \times CPRD)}{CLK_PWM}$$

By using a Master Clock divided by one of both DIVA or DIVB divider, the formula becomes, respectively:

$$\frac{(2 \times CPRD \times DIVA)}{CLK_PWM} \text{ or } \frac{(2 \times CPRD \times DIVB)}{CLK_PWM}$$

- the **waveform duty cycle**. This channel parameter is defined in the CDTY field of the CDTYx register.

If the waveform is left aligned then:

$$\text{duty cycle} = \frac{(\text{period} - 1 / f_{\text{channel_x_clock}} \times CDTY)}{\text{period}}$$

If the waveform is center aligned, then:

$$\text{duty cycle} = \frac{((\text{period}/2) - 1 / f_{\text{channel_x_clock}} \times CDTY)}{(\text{period}/2)}$$

- the **waveform polarity**. At the beginning of the period, the signal can be at high or low level. This property is defined in the CPOL field of the CMRx register. By default the signal starts by a low level.
- the **waveform alignment**. The output waveform can be left or center aligned. Center aligned waveforms can be used to generate non overlapped waveforms. This property is defined in the CALG field of the CMRx register. The default mode is left aligned.

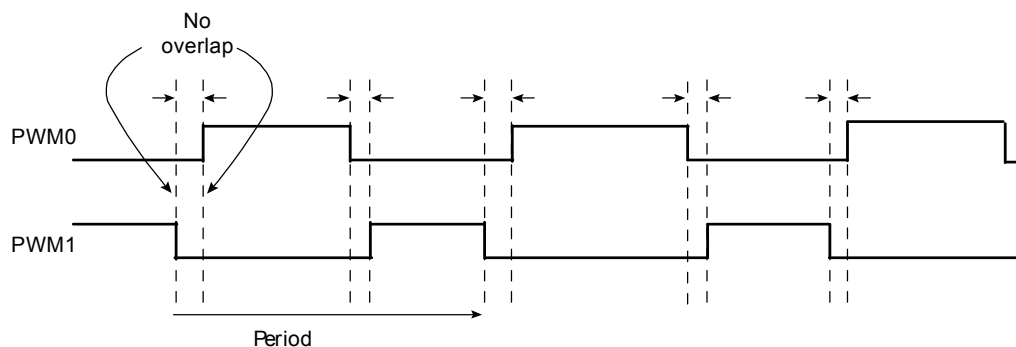
Figure 24-4. Non Overlapped Center Aligned Waveforms

Note: 1. See [Figure 24-5 on page 520](#) for a detailed description of center aligned waveforms.

When center aligned, the internal channel counter increases up to CPRD and decreases down to 0. This ends the period.

When left aligned, the internal channel counter increases up to CPRD and is reset. This ends the period.

Thus, for the same CPRD value, the period for a center aligned channel is twice the period for a left aligned channel.

Waveforms are fixed at 0 when:

- CDTY = CPRD and CPOL = 0
- CDTY = 0 and CPOL = 1

Waveforms are fixed at 1 (once the channel is enabled) when:

- CDTY = 0 and CPOL = 0
- CDTY = CPRD and CPOL = 1

The waveform polarity must be set before enabling the channel. This immediately affects the channel output level. Changes on channel polarity are not taken into account while the channel is enabled.

Figure 24-5. Waveform Properties

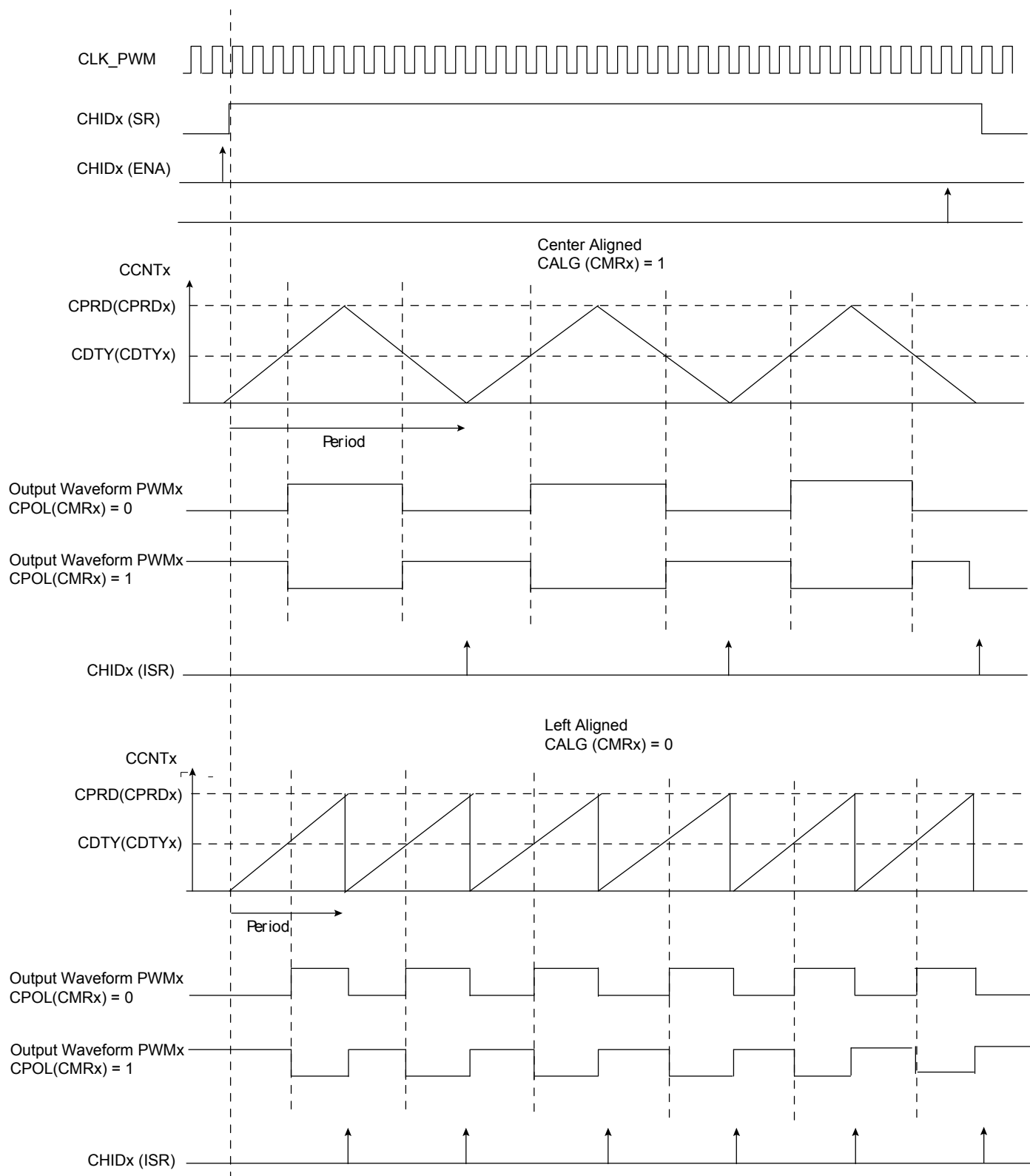

24.6.3 PWM Controller Operations

24.6.3.1 Initialization

Before enabling the output channel, this channel must have been configured by the software application:

- Configuration of the clock generator if DIVA and DIVB are required
- Selection of the clock for each channel (CPRE field in the CMRx register)
- Configuration of the waveform alignment for each channel (CALG field in the CMRx register)
- Configuration of the period for each channel (CPRD in the CPRDx register). Writing in CPRDx Register is possible while the channel is disabled. After validation of the channel, the user must use CUPDx Register to update CPRDx as explained below.
- Configuration of the duty cycle for each channel (CDTY in the CDTYx register). Writing in CDTYx Register is possible while the channel is disabled. After validation of the channel, the user must use CUPDx Register to update CDTYx as explained below.
- Configuration of the output waveform polarity for each channel (CPOL in the CMRx register)
- Enable Interrupts (Writing CHIDx in the IER register)
- Enable the PWM channel (Writing CHIDx in the ENA register)

It is possible to synchronize different channels by enabling them at the same time by means of writing simultaneously several CHIDx bits in the ENA register.

In such a situation, all channels may have the same clock selector configuration and the same period specified.

24.6.3.2 Source Clock Selection Criteria

The large number of source clocks can make selection difficult. The relationship between the value in the Period Register (CPRDx) and the Duty Cycle Register (CDTYx) can help the user in choosing. The event number written in the Period Register gives the PWM accuracy. The Duty Cycle quantum cannot be lower than $1/CPRDx$ value. The higher the value of CPRDx, the greater the PWM accuracy.

For example, if the user sets 15 (in decimal) in CPRDx, the user is able to set a value between 1 up to 14 in CDTYx Register. The resulting duty cycle quantum cannot be lower than $1/15$ of the PWM period.

24.6.3.3 Changing the Duty Cycle or the Period

It is possible to modulate the output waveform duty cycle or period.

To prevent unexpected output waveform, the user must use the update register (PWM_CUPDx) to change waveform parameters while the channel is still enabled. The user can write a new period value or duty cycle value in the update register (CUPDx). This register holds the new value until the end of the current cycle and updates the value for the next cycle. Depending on the CPD field in the CMRx register, CUPDx either updates CPRDx or CDTYx. Note that even if the update register is used, the period must not be smaller than the duty cycle.

Figure 24-6. Synchronized Period or Duty Cycle Update

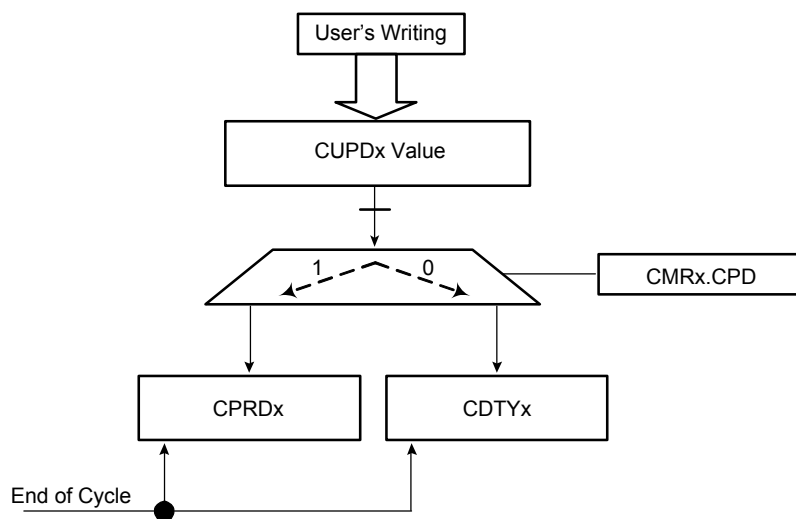

To prevent overwriting the CUPDx by software, the user can use status events in order to synchronize his software. Two methods are possible. In both, the user must enable the dedicated interrupt in IER at PWM Controller level.

The first method (polling method) consists of reading the relevant status bit in ISR Register according to the enabled channel(s). See [Figure 24-7](#).

The second method uses an Interrupt Service Routine associated with the PWM channel.

Note: Reading the ISR register automatically clears CHIDx flags.

Figure 24-7. Polling Method

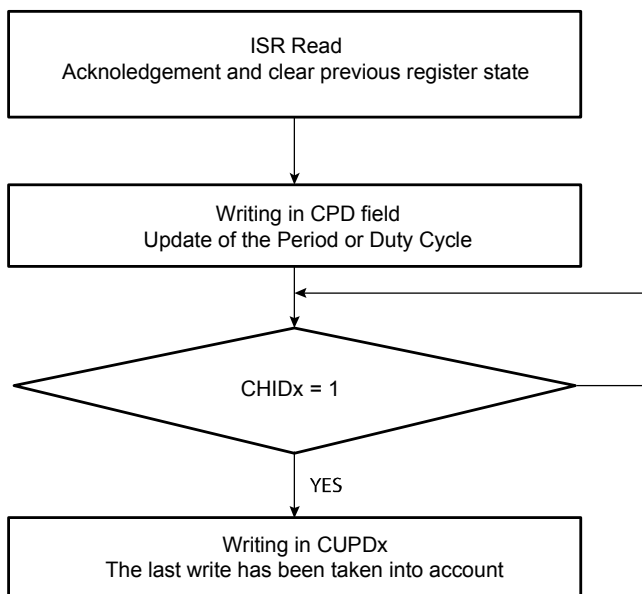

Note: Polarity and alignment can be modified only when the channel is disabled.

24.6.3.4 *Interrupts*

Depending on the interrupt mask in the IMR register, an interrupt is generated at the end of the corresponding channel period. The interrupt remains active until a read operation in the ISR register occurs.

A channel interrupt is enabled by setting the corresponding bit in the IER register. A channel interrupt is disabled by setting the corresponding bit in the IDR register.

24.7 User Interface

Table 24-2. PWM Controller Memory Map

| Offset | Register | Name | Access | Peripheral Reset Value |
|--------|-------------------------------|-------|------------|------------------------|
| 0x000 | Mode Register | MR | Read/Write | 0x00000000 |
| 0x004 | Enable Register | ENA | Write-only | - |
| 0x008 | Disable Register | DIS | Write-only | - |
| 0x00C | Status Register | SR | Read-only | 0x00000000 |
| 0x010 | Interrupt Enable Register | IER | Write-only | - |
| 0x014 | Interrupt Disable Register | IDR | Write-only | - |
| 0x018 | Interrupt Mask Register | IMR | Read-only | 0x00000000 |
| 0x01C | Interrupt Status Register | ISR | Read-only | 0x00000000 |
| 0x200 | Channel 0 Mode Register | CMR0 | Read/Write | 0x00000000 |
| 0x204 | Channel 0 Duty Cycle Register | CDTY0 | Read/Write | 0x00000000 |
| 0x208 | Channel 0 Period Register | CPRD0 | Read/Write | 0x00000000 |
| 0x20C | Channel 0 Counter Register | CCNT0 | Read-only | 0x00000000 |
| 0x210 | Channel 0 Update Register | CUPD0 | Write-only | - |
| 0x220 | Channel 1 Mode Register | CMR1 | Read/Write | 0x00000000 |
| 0x224 | Channel 1 Duty Cycle Register | CDTY1 | Read/Write | 0x00000000 |
| 0x228 | Channel 1 Period Register | CPRD1 | Read/Write | 0x00000000 |
| 0x22C | Channel 1 Counter Register | CCNT1 | Read-only | 0x00000000 |
| 0x230 | Channel 1 Update Register | CUPD1 | Write-only | - |

24.7.1 Mode Register

Name: MR
Access Type: Read/Write
Offset: 0x000
Reset Value: 0x00000000

| | | | | | | | |
|------|----|----|----|------|----|----|----|
| 31 | 30 | 29 | 28 | 27 | 26 | 25 | 24 |
| – | – | – | – | PREB | | | |
| 23 | 22 | 21 | 20 | 19 | 18 | 17 | 16 |
| DIVB | | | | | | | |
| 15 | 14 | 13 | 12 | 11 | 10 | 9 | 8 |
| – | – | – | – | PREA | | | |
| 7 | 6 | 5 | 4 | 3 | 2 | 1 | 0 |
| DIVA | | | | | | | |

- DIVA, DIVB: CLKA, CLKB Divide Factor**

| DIVA, DIVB | CLKA, CLKB |
|------------|--|
| 0 | CLKA, CLKB clock is turned off |
| 1 | CLKA, CLKB clock is clock selected by PREA, PREB |
| 2-255 | CLKA, CLKB clock is clock selected by PREA, PREB divided by DIVA, DIVB factor. |

- PREA, PREB**

| PREA, PREB | | | | Divider Input Clock |
|------------|---|---|---|---------------------|
| 0 | 0 | 0 | 0 | CLK_PWM. |
| 0 | 0 | 0 | 1 | CLK_PWM/2 |
| 0 | 0 | 1 | 0 | CLK_PWM/4 |
| 0 | 0 | 1 | 1 | CLK_PWM/8 |
| 0 | 1 | 0 | 0 | CLK_PWM/16 |
| 0 | 1 | 0 | 1 | CLK_PWM/32 |
| 0 | 1 | 1 | 0 | CLK_PWM/64 |
| 0 | 1 | 1 | 1 | CLK_PWM/128 |
| 1 | 0 | 0 | 0 | CLK_PWM/256 |
| 1 | 0 | 0 | 1 | CLK_PWM/512 |
| 1 | 0 | 1 | 0 | CLK_PWM/1024 |
| Other | | | | Reserved |

24.7.2 Enable Register

Name: ENA

Access Type: Write-only

Offset: 0x004

Reset Value: -

| | | | | | | | |
|----|-------|-------|-------|-------|-------|-------|-------|
| 31 | 30 | 29 | 28 | 27 | 26 | 25 | 24 |
| - | - | - | - | - | - | - | - |
| 23 | 22 | 21 | 20 | 19 | 18 | 17 | 16 |
| - | - | - | - | - | - | - | - |
| 15 | 14 | 13 | 12 | 11 | 10 | 9 | 8 |
| - | - | - | - | - | - | - | - |
| 7 | 6 | 5 | 4 | 3 | 2 | 1 | 0 |
| - | CHID6 | CHID5 | CHID4 | CHID3 | CHID2 | CHID1 | CHID0 |

- **CHIDx: Channel ID**

1: Writing a one to this bit will enable PWM output for channel x.

0: Writing a zero to this bit has no effect.

24.7.3 Disable Register

Name: DIS
Access Type: Write-only
Offset: 0x008
Reset Value: -

| | | | | | | | |
|----|-------|-------|-------|-------|-------|-------|-------|
| 31 | 30 | 29 | 28 | 27 | 26 | 25 | 24 |
| - | - | - | - | - | - | - | - |
| 23 | 22 | 21 | 20 | 19 | 18 | 17 | 16 |
| - | - | - | - | - | - | - | - |
| 15 | 14 | 13 | 12 | 11 | 10 | 9 | 8 |
| - | - | - | - | - | - | - | - |
| 7 | 6 | 5 | 4 | 3 | 2 | 1 | 0 |
| - | CHID6 | CHID5 | CHID4 | CHID3 | CHID2 | CHID1 | CHID0 |

- **CHIDx: Channel ID**
 - 1: Writing a one to this bit will disable PWM output for channel x.
 - 0: Writing a zero to this bit has no effect.

24.7.4 Status Register

Name: SR
Access Type: Read-only
Offset: 0x00C
Reset Value: 0x00000000

| | | | | | | | |
|----|-------|-------|-------|-------|-------|-------|-------|
| 31 | 30 | 29 | 28 | 27 | 26 | 25 | 24 |
| – | – | – | – | – | – | – | – |
| 23 | 22 | 21 | 20 | 19 | 18 | 17 | 16 |
| – | – | – | – | – | – | – | – |
| 15 | 14 | 13 | 12 | 11 | 10 | 9 | 8 |
| – | – | – | – | – | – | – | – |
| 7 | 6 | 5 | 4 | 3 | 2 | 1 | 0 |
| – | CHID6 | CHID5 | CHID4 | CHID3 | CHID2 | CHID1 | CHID0 |

- **CHIDx: Channel ID**

0: PWM output for channel x is disabled.

1: PWM output for channel x is enabled.

24.7.5 Interrupt Enable Register

Name: IER
Access Type: Write-only
Offset: 0x010
Reset Value: -

| | | | | | | | |
|----|-------|-------|-------|-------|-------|-------|-------|
| 31 | 30 | 29 | 28 | 27 | 26 | 25 | 24 |
| - | - | - | - | - | - | - | - |
| 23 | 22 | 21 | 20 | 19 | 18 | 17 | 16 |
| - | - | - | - | - | - | - | - |
| 15 | 14 | 13 | 12 | 11 | 10 | 9 | 8 |
| - | - | - | - | - | - | - | - |
| 7 | 6 | 5 | 4 | 3 | 2 | 1 | 0 |
| - | CHID6 | CHID5 | CHID4 | CHID3 | CHID2 | CHID1 | CHID0 |

Writing a zero to a bit in this register has no effect.
 Writing a one to a bit in this register will set the corresponding bit in IMR.

24.7.6 Interrupt Disable Register

Name: IDR
Access Type: Write-only
Offset: 0x014
Reset Value: -

| | | | | | | | |
|----|-------|-------|-------|-------|-------|-------|-------|
| 31 | 30 | 29 | 28 | 27 | 26 | 25 | 24 |
| - | - | - | - | - | - | - | - |
| 23 | 22 | 21 | 20 | 19 | 18 | 17 | 16 |
| - | - | - | - | - | - | - | - |
| 15 | 14 | 13 | 12 | 11 | 10 | 9 | 8 |
| - | - | - | - | - | - | - | - |
| 7 | 6 | 5 | 4 | 3 | 2 | 1 | 0 |
| - | CHID6 | CHID5 | CHID4 | CHID3 | CHID2 | CHID1 | CHID0 |

Writing a zero to a bit in this register has no effect.

Writing a one to a bit in this register will clear the corresponding bit in IMR.

24.7.7 Interrupt Mask Register

Name: IMR
Access Type: Read-only
Offset: 0x018
Reset Value: 0x00000000

| | | | | | | | |
|----|-------|-------|-------|-------|-------|-------|-------|
| 31 | 30 | 29 | 28 | 27 | 26 | 25 | 24 |
| – | – | – | – | – | – | – | – |
| 23 | 22 | 21 | 20 | 19 | 18 | 17 | 16 |
| – | – | – | – | – | – | – | – |
| 15 | 14 | 13 | 12 | 11 | 10 | 9 | 8 |
| – | – | – | – | – | – | – | – |
| 7 | 6 | 5 | 4 | 3 | 2 | 1 | 0 |
| – | CHID6 | CHID5 | CHID4 | CHID3 | CHID2 | CHID1 | CHID0 |

0: The corresponding interrupt is disabled.

1: The corresponding interrupt is enabled.

A bit in this register is cleared when the corresponding bit in IDR is written to one.

A bit in this register is set when the corresponding bit in IER is written to one.

24.7.8 Interrupt Status Register

Name: ISR
Access Type: Read-only
Offset: 0x01C
Reset Value: 0x00000000

| | | | | | | | |
|----|-------|-------|-------|-------|-------|-------|-------|
| 31 | 30 | 29 | 28 | 27 | 26 | 25 | 24 |
| – | – | – | – | – | – | – | – |
| 23 | 22 | 21 | 20 | 19 | 18 | 17 | 16 |
| – | – | – | – | – | – | – | – |
| 15 | 14 | 13 | 12 | 11 | 10 | 9 | 8 |
| – | – | – | – | – | – | – | – |
| 7 | 6 | 5 | 4 | 3 | 2 | 1 | 0 |
| – | CHID6 | CHID5 | CHID4 | CHID3 | CHID2 | CHID1 | CHID0 |

- **CHIDx: Channel ID**

0 = No new channel period since the last read of the ISR register.

1 = At least one new channel period since the last read of the ISR register.

Note: Reading ISR automatically clears CHIDx flags.

24.7.9 Channel Mode Register

Name: CMRx

Access Type: Read/Write

Offset: 0x200

Reset Value: 0x00000000

| | | | | | | | |
|----|----|----|----|------|-----|------|------|
| 31 | 30 | 29 | 28 | 27 | 26 | 25 | 24 |
| – | – | – | – | – | – | – | – |
| 23 | 22 | 21 | 20 | 19 | 18 | 17 | 16 |
| – | – | – | – | – | – | – | – |
| 15 | 14 | 13 | 12 | 11 | 10 | 9 | 8 |
| – | – | – | – | – | CPD | CPOL | CALG |
| 7 | 6 | 5 | 4 | 3 | 2 | 1 | 0 |
| – | – | – | – | CPRE | | | |

- **CPD: Channel Update Period**

0 = Writing a zero to this bit will modify the duty cycle at the next period start event.

1 = Writing a one to this bit will modify the period at the next period start event.

- **CPOL: Channel Polarity**

0 = Writing a zero to this bit with configure the output waveform to start at a low level.

1 = Writing a one to this bit with configure the output waveform to start at a high level.

- **CALG: Channel Alignment**

0 = Writing a zero to this bit with configure the period to be left aligned.

1 = Writing a one to this bit with configure the period to be center aligned.

- CPRE: Channel Pre-scaler

| CPRE | | | | Channel Pre-scaler |
|-------|---|---|---|--------------------|
| 0 | 0 | 0 | 0 | CLK_PWM |
| 0 | 0 | 0 | 1 | CLK_PWM/2 |
| 0 | 0 | 1 | 0 | CLK_PWM/4 |
| 0 | 0 | 1 | 1 | CLK_PWM/8 |
| 0 | 1 | 0 | 0 | CLK_PWM/16 |
| 0 | 1 | 0 | 1 | CLK_PWM/32 |
| 0 | 1 | 1 | 0 | CLK_PWM/64 |
| 0 | 1 | 1 | 1 | CLK_PWM/128 |
| 1 | 0 | 0 | 0 | CLK_PWM/256 |
| 1 | 0 | 0 | 1 | CLK_PWM/512 |
| 1 | 0 | 1 | 0 | CLK_PWM/1024 |
| 1 | 0 | 1 | 1 | CLKA |
| 1 | 1 | 0 | 0 | CLKB |
| Other | | | | Reserved |

24.7.10 Channel Duty Cycle Register

Name: CDTYx
Access Type: Read/Write
Offset: 0x204
Reset Value: 0x00000000

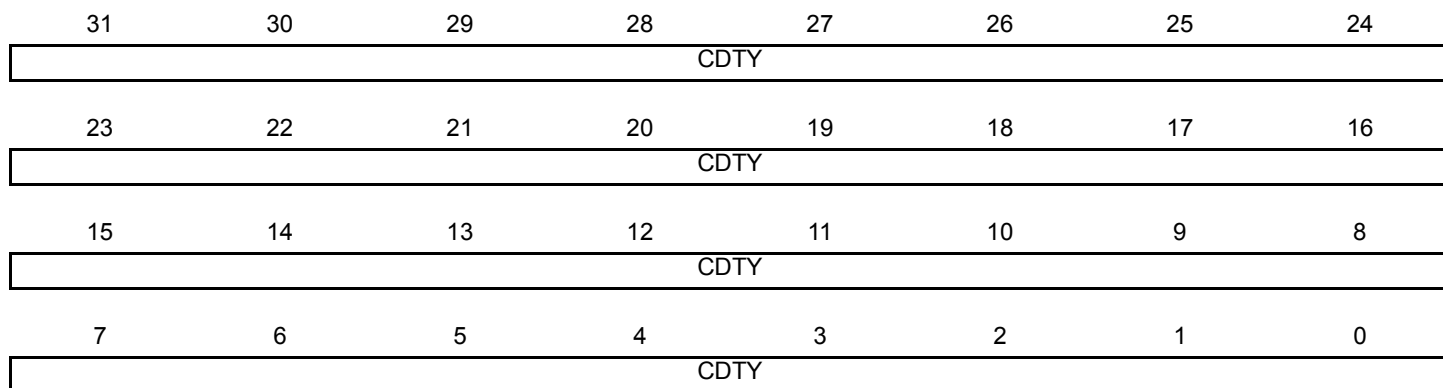

Only the first 20 bits (internal channel counter size) are significant.

- **CDTY: Channel Duty Cycle**
 Defines the waveform duty cycle. This value must be defined between 0 and CPRD (CPRx).

24.7.11 Channel Period Register

Name: CPRDx
Access Type: Read/Write
Offset: 0x208
Reset Value: 0x00000000

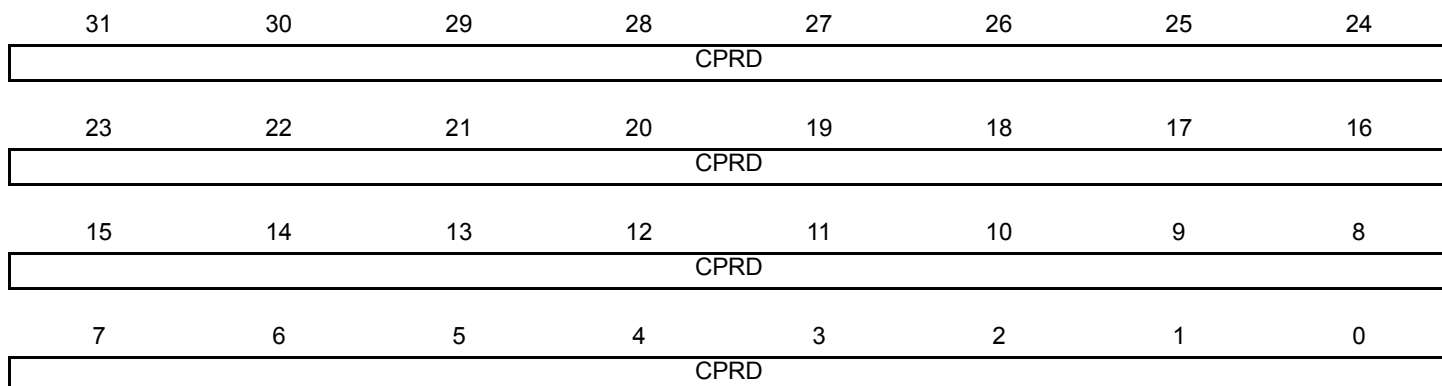

Only the first 20 bits (internal channel counter size) are significant.

- **CPRD: Channel Period**

If the waveform is left-aligned, then the output waveform period depends on the counter source clock and can be calculated:

- By using the Master Clock (CLK_PWM) divided by an X given prescaler value (with X being 1, 2, 4, 8, 16, 32, 64, 128, 256, 512, or 1024). The resulting period formula will be:

$$\frac{(X \times CPRD)}{CLK_PWM}$$

- By using a Master Clock divided by one of both DIVA or DIVB divider, the formula becomes, respectively:

$$\frac{(CPRD \times DIVA)}{CLK_PWM} \text{ or } \frac{(CPRD \times DIVB)}{CLK_PWM}$$

If the waveform is center-aligned, then the output waveform period depends on the counter source clock and can be calculated:

- By using the Master Clock (CLK_PWM) divided by an X given prescaler value (with X being 1, 2, 4, 8, 16, 32, 64, 128, 256, 512, or 1024). The resulting period formula will be:

$$\frac{(2 \times X \times CPRD)}{CLK_PWM}$$

- By using a Master Clock divided by one of both DIVA or DIVB divider, the formula becomes, respectively:

$$\frac{(2 \times CPRD \times DIVA)}{CLK_PWM} \text{ or } \frac{(2 \times CPRD \times DIVB)}{CLK_PWM}$$

24.7.12 Channel Counter Register

Name: CCNTx
Access Type: Read-only
Offset: 0x20C
Reset Value: 0x00000000

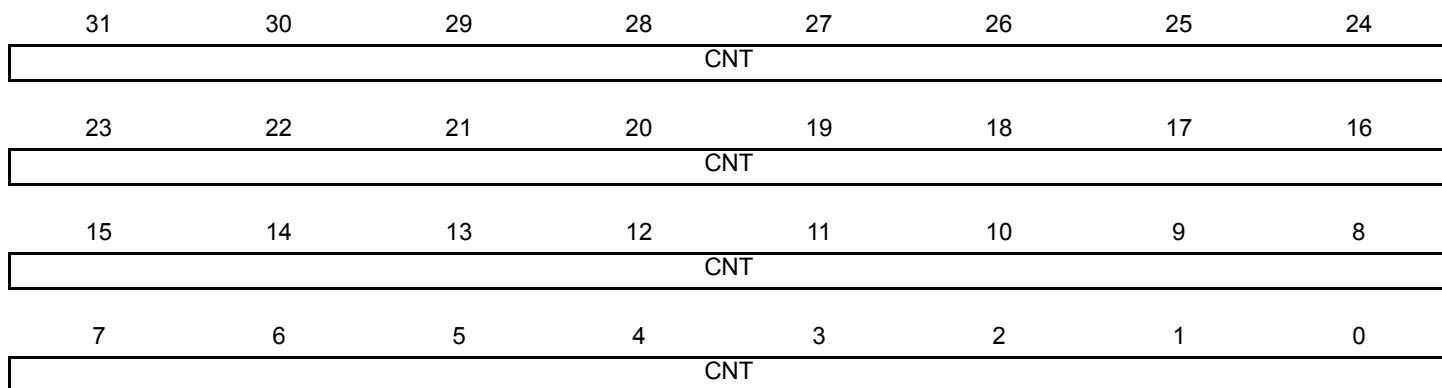

- **CNT: Channel Counter Register**
 Internal counter value. This register is reset when the counter reaches the CPRD value defined in the CPRDx register if the waveform is left aligned.

24.7.13 Channel Update Register

Name: CUPDx
Access Type: Write-only
Offset: 0x210
Reset Value: 0x00000000

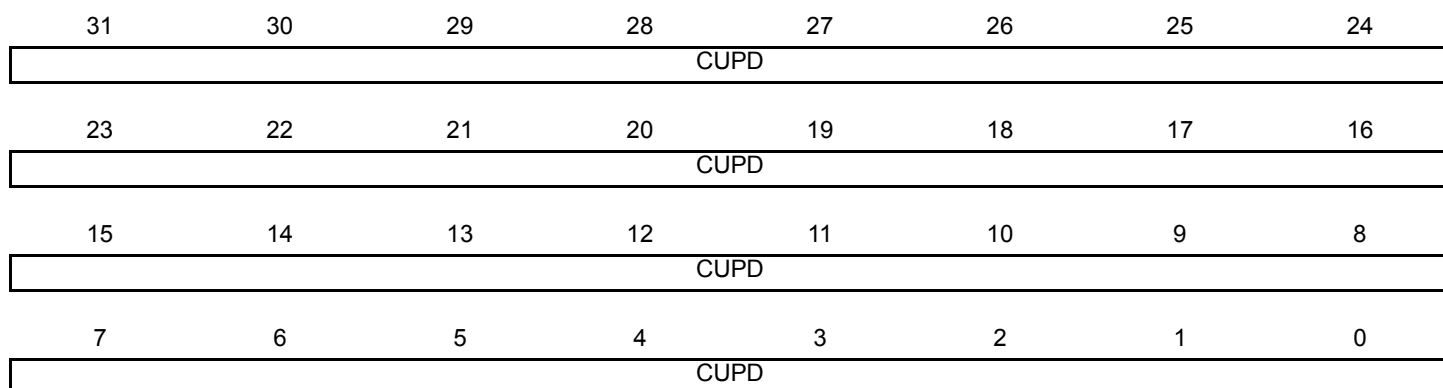

This register acts as a double buffer for the period or the duty cycle. This prevents an unexpected waveform when modifying the waveform period or duty-cycle.

Only the first 20 bits (internal channel counter size) are significant.

| • CPD (CMRx Register) | |
|-----------------------|---|
| 0 | The duty-cycle (CDTY in the CDTYx register) is updated with the CUPD value at the beginning of the next period. |
| 1 | The period (CPRD in the CPRDx register) is updated with the CUPD value at the beginning of the next period. |

25. Analog-to-Digital Converter (ADC)

Rev: 2.0.0.1

25.1 Features

- **Integrated multiplexer offering up to eight independent analog inputs**
- **Individual enable and disable of each channel**
- **Hardware or software trigger**
 - External trigger pin
 - Timer counter outputs (corresponding TIOA trigger)
- **Peripheral DMA Controller support**
- **Possibility of ADC timings configuration**
- **Sleep mode and conversion sequencer**
 - Automatic wakeup on trigger and back to sleep mode after conversions of all enabled channels

25.2 Overview

The Analog-to-Digital Converter (ADC) is based on a Successive Approximation Register (SAR) 10-bit ADC. It also integrates an 8-to-1 analog multiplexer, making possible the analog-to-digital conversions of 8 analog lines. The conversions extend from 0V to ADVREF.

The ADC supports an 8-bit or 10-bit resolution mode, and conversion results are reported in a common register for all channels, as well as in a channel-dedicated register. Software trigger, external trigger on rising edge of the TRIGGER pin, or internal triggers from timer counter output(s) are configurable.

The ADC also integrates a sleep mode and a conversion sequencer and connects with a Peripheral DMA Controller channel. These features reduce both power consumption and processor intervention.

Finally, the user can configure ADC timings, such as startup time and sample & hold time.

25.3 Block Diagram

Figure 25-1. ADC Block Diagram

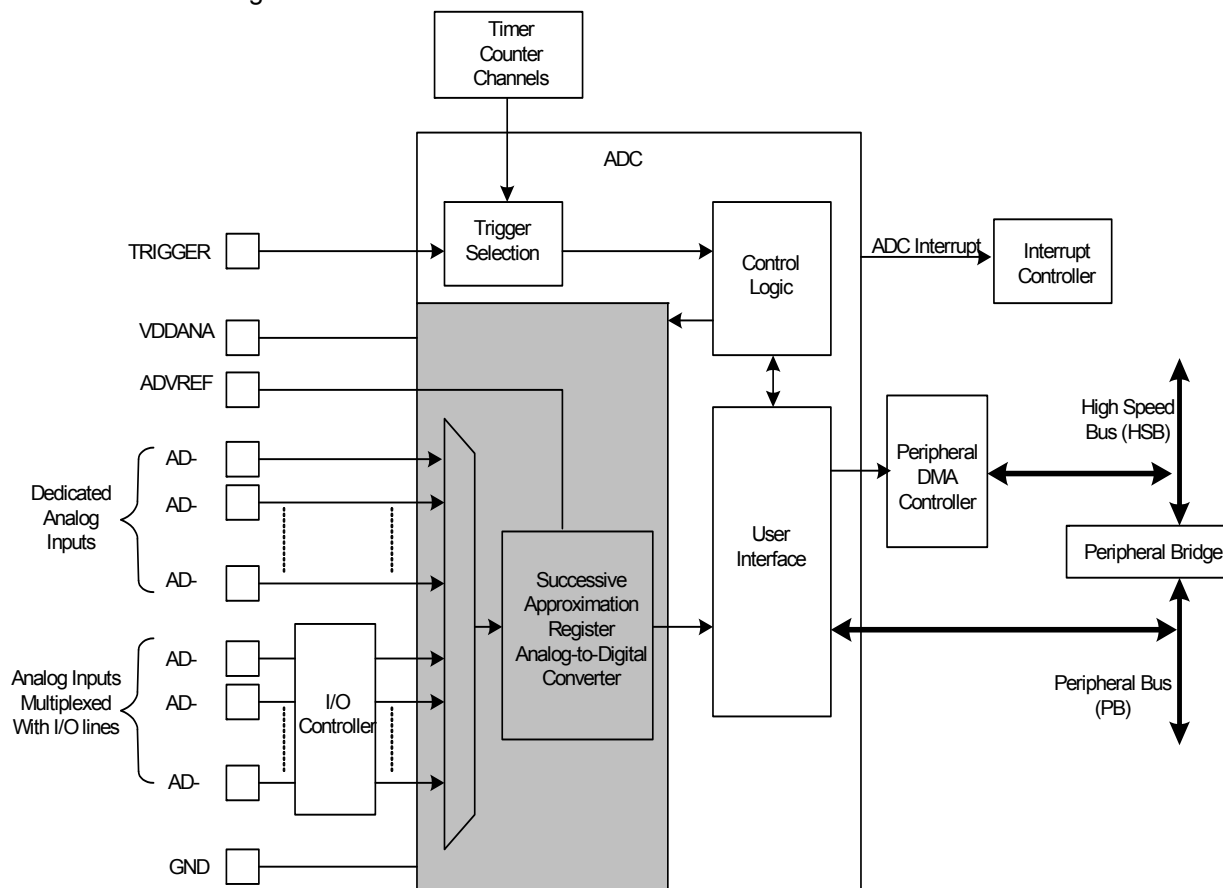

25.4 I/O Lines Description

Table 25-1. ADC Pins Description

| Pin Name | Description |
|---------------|-----------------------|
| VDDANA | Analog power supply |
| ADVREF | Reference voltage |
| AD[0] - AD[7] | Analog input channels |
| TRIGGER | External trigger |

25.5 Product Dependencies

In order to use this module, other parts of the system must be configured correctly, as described below.

25.5.1 I/O Lines

The TRIGGER pin may be shared with other peripheral functions through the I/O Controller.

25.5.2 Power Management

In sleep mode, the ADC clock is automatically stopped after each conversion. As the logic is small and the ADC cell can be put into sleep mode, the Power Manager has no effect on the ADC behavior.

25.5.3 Clocks

The clock for the ADC bus interface (CLK_ADC) is generated by the Power Manager. This clock is enabled at reset, and can be disabled in the Power Manager. It is recommended to disable the ADC before disabling the clock, to avoid freezing the ADC in an undefined state.

The CLK_ADC clock frequency must be in line with the ADC characteristics. Refer to Electrical Characteristics section for details.

25.5.4 Interrupts

The ADC interrupt request line is connected to the interrupt controller. Using the ADC interrupt requires the interrupt controller to be programmed first.

25.5.5 Analog Inputs

The analog input pins can be multiplexed with I/O lines. In this case, the assignment of the ADC input is automatically done as soon as the corresponding I/O is configured through the I/O controller. By default, after reset, the I/O line is configured as a logic input.

25.5.6 Timer Triggers

Timer Counters may or may not be used as hardware triggers depending on user requirements. Thus, some or all of the timer counters may be non-connected.

25.6 Functional Description

25.6.1 Analog-to-digital Conversion

The ADC uses the ADC Clock to perform conversions. Converting a single analog value to a 10-bit digital data requires sample and hold clock cycles as defined in the Sample and Hold Time field of the Mode Register (MR.SHTIM) and 10 ADC Clock cycles. The ADC Clock frequency is selected in the Prescaler Rate Selection field of the MR register (MR.PRESCAL).

The ADC Clock range is between $\text{CLK_ADC}/2$, if the PRESCAL field is 0, and $\text{CLK_ADC}/128$, if the PRESCAL field is 63 (0x3F). The PRESCAL field must be written in order to provide an ADC Clock frequency according to the parameters given in the Electrical Characteristics chapter.

25.6.2 Conversion Reference

The conversion is performed on a full range between 0V and the reference voltage pin ADVREF. Analog input values between these voltages are converted to digital values based on a linear conversion.

25.6.3 Conversion Resolution

The ADC supports 8-bit or 10-bit resolutions. The 8-bit selection is performed by writing a one to the Resolution bit in the MR register (MR.LOWRES). By default, after a reset, the resolution is the highest and the Converted Data field in the Channel Data Registers (CDRn.DATA) is fully used. By writing a one to the LOWRES bit, the ADC switches in the lowest resolution and the conversion results can be read in the eight lowest significant bits of the Channel Data Registers (CDRn). The two highest bits of the DATA field in the corresponding CDRn register will be read

as zero. The two highest bits of the Last Data Converted field in the Last Converted Data Register (LCDR.LDATA) will be read as zero too.

Moreover, when a Peripheral DMA channel is connected to the ADC, a 10-bit resolution sets the transfer request size to 16-bit. Writing a one to the LOWRES bit automatically switches to 8-bit data transfers. In this case, the destination buffers are optimized.

25.6.4 Conversion Results

When a conversion is completed, the resulting 10-bit digital value is stored in the CDR register of the current channel and in the LCDR register. Channels are enabled by writing a one to the Channel n Enable bit (CHn) in the CHER register.

The corresponding channel End of Conversion bit in the Status Register (SR.EOCn) and the Data Ready bit in the SR register (SR.DRDY) are set. In the case of a connected Peripheral DMA channel, DRDY rising triggers a data transfer request. In any case, either EOC or DRDY can trigger an interrupt.

Reading one of the CDRn registers clears the corresponding EOC bit. Reading LCDR clears the DRDY bit and the EOC bit corresponding to the last converted channel.

Figure 25-2. EOCn and DRDY Flag Behavior

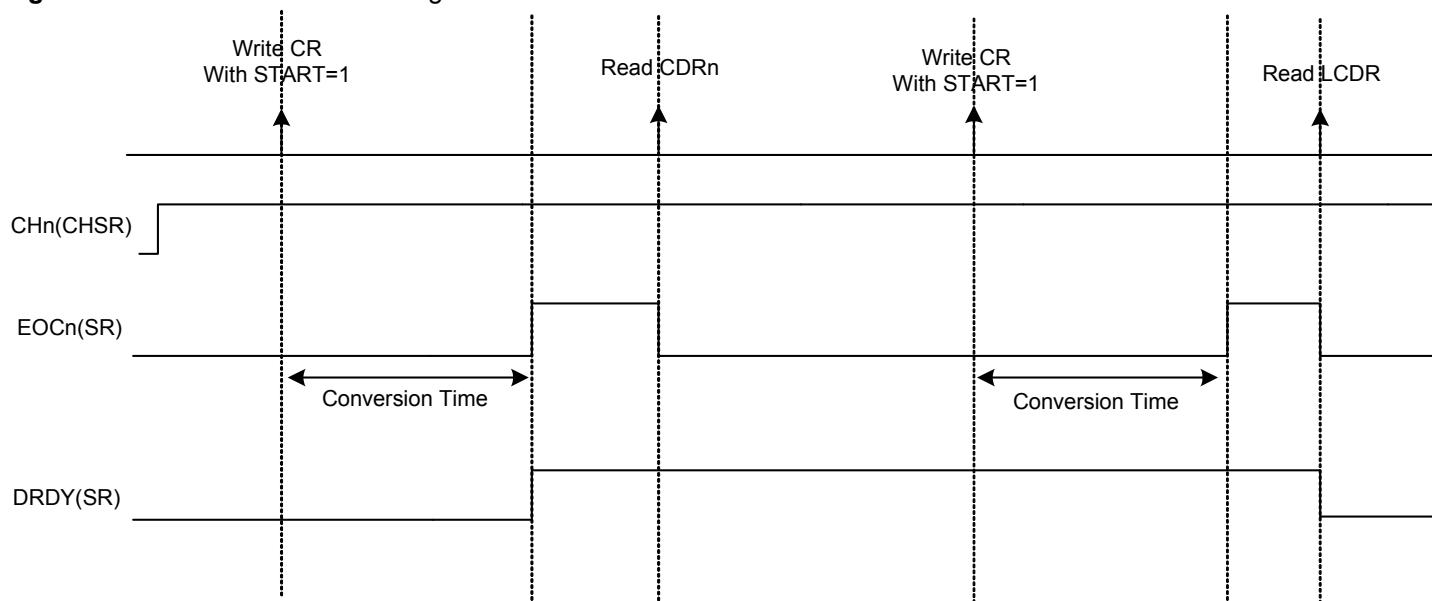

If the CDR register is not read before further incoming data is converted, the corresponding Overrun Error bit in the SR register (SR.OVREn) is set.

In the same way, new data converted when DRDY is high sets the General Overrun Error bit in the SR register (SR.GOVRE).

The OVREn and GOVRE bits are automatically cleared when the SR register is read.

Figure 25-3. GOVRE and OVREn Flag Behavior

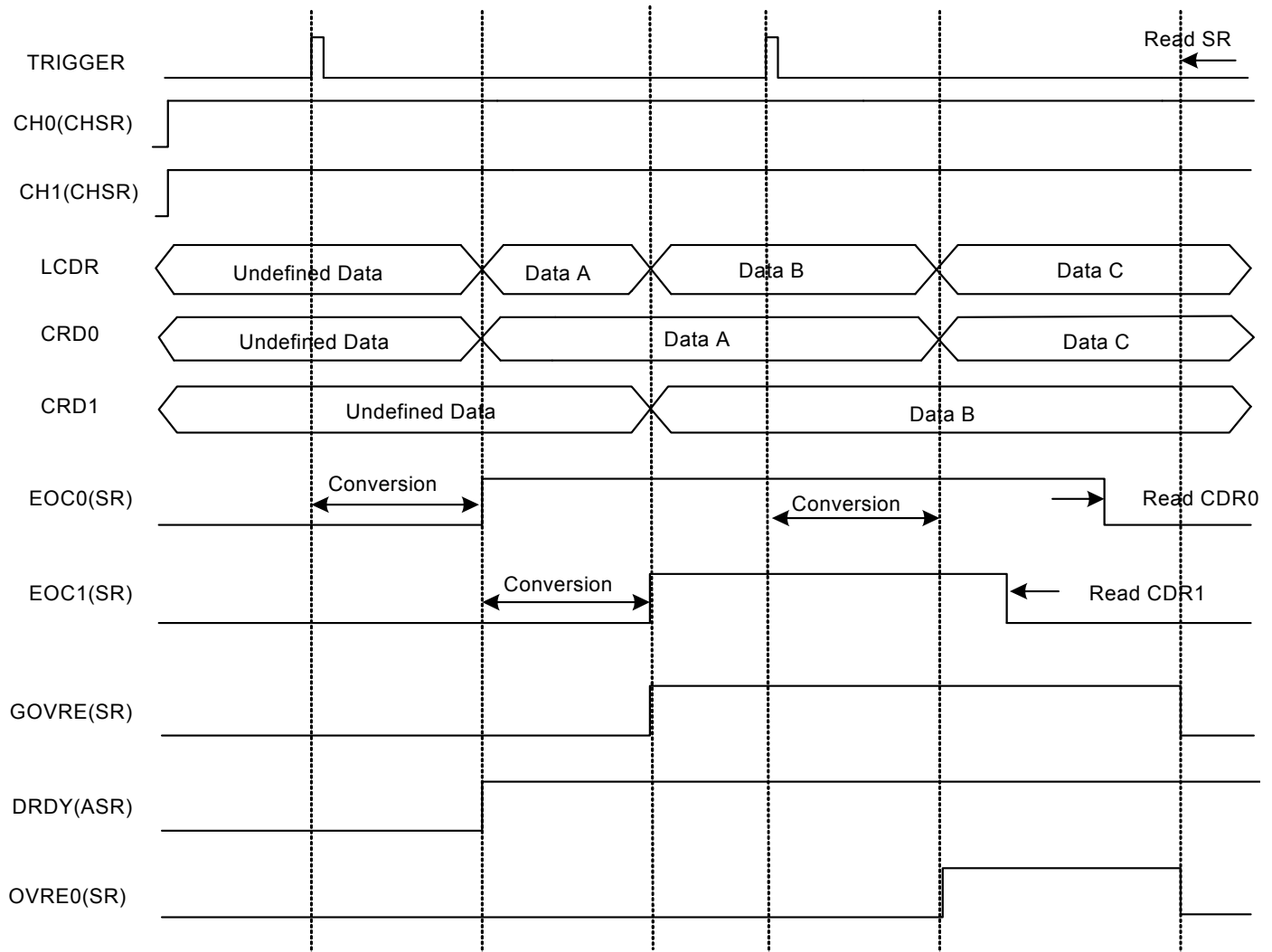

Warning: If the corresponding channel is disabled during a conversion or if it is disabled and then reenabled during a conversion, its associated data and its corresponding EOC and OVRE flags in SR are unpredictable.

25.6.5 Conversion Triggers

Conversions of the active analog channels are started with a software or a hardware trigger. The software trigger is provided by writing a one to the START bit in the Control Register (CR.START).

The hardware trigger can be one of the TIOA outputs of the Timer Counter channels, or the external trigger input of the ADC (TRIGGER). The hardware trigger is selected with the Trigger Selection field in the Mode Register (MR.TRIGSEL). The selected hardware trigger is enabled by writing a one to the Trigger Enable bit in the Mode Register (MR.TRGEN).

If a hardware trigger is selected, the start of a conversion is detected at each rising edge of the selected signal. If one of the TIOA outputs is selected, the corresponding Timer Counter channel must be programmed in Waveform Mode.

Only one start command is necessary to initiate a conversion sequence on all the channels. The ADC hardware logic automatically performs the conversions on the active channels, then waits for a new request. The Channel Enable (CHER) and Channel Disable (CHDR) Registers enable the analog channels to be enabled or disabled independently.

If the ADC is used with a Peripheral DMA Controller, only the transfers of converted data from enabled channels are performed and the resulting data buffers should be interpreted accordingly.

Warning: Enabling hardware triggers does not disable the software trigger functionality. Thus, if a hardware trigger is selected, the start of a conversion can be initiated either by the hardware or the software trigger.

25.6.6 Sleep Mode and Conversion Sequencer

The ADC Sleep Mode maximizes power saving by automatically deactivating the ADC when it is not being used for conversions. Sleep Mode is selected by writing a one to the Sleep Mode bit in the Mode Register (MR.SLEEP).

The SLEEP mode is automatically managed by a conversion sequencer, which can automatically process the conversions of all channels at lowest power consumption.

When a start conversion request occurs, the ADC is automatically activated. As the analog cell requires a start-up time, the logic waits during this time and starts the conversion on the enabled channels. When all conversions are complete, the ADC is deactivated until the next trigger. Triggers occurring during the sequence are not taken into account.

The conversion sequencer allows automatic processing with minimum processor intervention and optimized power consumption. Conversion sequences can be performed periodically using a Timer/Counter output. The periodic acquisition of several samples can be processed automatically without any intervention of the processor thanks to the Peripheral DMA Controller.

Note: The reference voltage pins always remain connected in normal mode as in sleep mode.

25.6.7 ADC Timings

Each ADC has its own minimal startup time that is defined through the Start Up Time field in the Mode Register (MR.STARTUP). This startup time is given in the Electrical Characteristics chapter.

In the same way, a minimal sample and hold time is necessary for the ADC to guarantee the best converted final value between two channels selection. This time has to be defined through the Sample and Hold Time field in the Mode Register (MR.SHTIM). This time depends on the input impedance of the analog input, but also on the output impedance of the driver providing the signal to the analog input, as there is no input buffer amplifier.

25.6.8 Conversion Performances

For performance and electrical characteristics of the ADC, see the Electrical Characteristics chapter.

25.7 User Interface

Table 25-2. ADC Register Memory Map

| Offset | Register | Name | Access | Reset State |
|--------|---|---------|------------|------------------|
| 0x00 | Control Register | CR | Write-only | 0x00000000 |
| 0x04 | Mode Register | MR | Read/Write | 0x00000000 |
| 0x10 | Channel Enable Register | CHER | Write-only | 0x00000000 |
| 0x14 | Channel Disable Register | CHDR | Write-only | 0x00000000 |
| 0x18 | Channel Status Register | CHSR | Read-only | 0x00000000 |
| 0x1C | Status Register | SR | Read-only | 0x000C0000 |
| 0x20 | Last Converted Data Register | LCDR | Read-only | 0x00000000 |
| 0x24 | Interrupt Enable Register | IER | Write-only | 0x00000000 |
| 0x28 | Interrupt Disable Register | IDR | Write-only | 0x00000000 |
| 0x2C | Interrupt Mask Register | IMR | Read-only | 0x00000000 |
| 0x30 | Channel Data Register 0 | CDR0 | Read-only | 0x00000000 |
| ... | ...(if implemented) | ... | ... | ... |
| 0x4C | Channel Data Register 7(if implemented) | CDR7 | Read-only | 0x00000000 |
| 0xFC | Version Register | VERSION | Read-only | - ⁽¹⁾ |

Note: 1. The reset values are device specific. Please refer to the Module Configuration section at the end of this chapter.

25.7.1 Control Register

Name: CR
Access Type: Write-only
Offset: 0x00
Reset Value: 0x00000000

| | | | | | | | |
|----|----|----|----|----|----|-------|-------|
| 31 | 30 | 29 | 28 | 27 | 26 | 25 | 24 |
| – | – | – | – | – | – | – | – |
| 23 | 22 | 21 | 20 | 19 | 18 | 17 | 16 |
| – | – | – | – | – | – | – | – |
| 15 | 14 | 13 | 12 | 11 | 10 | 9 | 8 |
| – | – | – | – | – | – | – | – |
| 7 | 6 | 5 | 4 | 3 | 2 | 1 | 0 |
| – | – | – | – | – | – | START | SWRST |

- **START: Start Conversion**
 Writing a one to this bit will begin an analog-to-digital conversion.
 Writing a zero to this bit has no effect.
 This bit always reads zero.
- **SWRST: Software Reset**
 Writing a one to this bit will reset the ADC.
 Writing a zero to this bit has no effect.
 This bit always reads zero.

25.7.2 Mode Register

Name: MR
Access Type: Read/Write
Offset: 0x04
Reset Value: 0x00000000

| | | | | | | | |
|---------|---------|-------|--------|--------|----|----|-------|
| 31 | 30 | 29 | 28 | 27 | 26 | 25 | 24 |
| – | – | – | – | SHTIM | | | |
| 23 | 22 | 21 | 20 | 19 | 18 | 17 | 16 |
| – | STARTUP | | | | | | |
| 15 | 14 | 13 | 12 | 11 | 10 | 9 | 8 |
| PRESCAL | | | | | | | |
| 7 | 6 | 5 | 4 | 3 | 2 | 1 | 0 |
| – | – | SLEEP | LOWRES | TRGSEL | | | TRGEN |

- **SHTIM: Sample & Hold Time**
 Sample & Hold Time = (SHTIM+3) / ADCClock
- **STARTUP: Start Up Time**
 Startup Time = (STARTUP+1) * 8 / ADCClock
 This Time should respect a minimal value. Refer to Electrical Characteristics section for details.
- **PRESCAL: Prescaler Rate Selection**
 ADCClock = CLK_ADC / ((PRESCAL+1) * 2)
- **SLEEP: Sleep Mode**
 1: Sleep Mode is selected.
 0: Normal Mode is selected.
- **LOWRES: Resolution**
 1: 8-bit resolution is selected.
 0: 10-bit resolution is selected.
- **TRGSEL: Trigger Selection**

| TRGSEL | | | Selected TRGSEL |
|--------|---|---|---|
| 0 | 0 | 0 | Internal Trigger 0, depending of chip integration |
| 0 | 0 | 1 | Internal Trigger 1, depending of chip integration |
| 0 | 1 | 0 | Internal Trigger 2, depending of chip integration |
| 0 | 1 | 1 | Internal Trigger 3, depending of chip integration |
| 1 | 0 | 0 | Internal Trigger 4, depending of chip integration |
| 1 | 0 | 1 | Internal Trigger 5, depending of chip integration |
| 1 | 1 | 0 | External trigger |

- **TRGEN: Trigger Enable**
 1: The hardware trigger selected by the TRGSEL field is enabled.
 0: The hardware triggers are disabled. Starting a conversion is only possible by software.

25.7.3 Channel Enable Register

Name: CHER
Access Type: Write-only
Offset: 0x10
Reset Value: 0x00000000

| | | | | | | | |
|-----|-----|-----|-----|-----|-----|-----|-----|
| 31 | 30 | 29 | 28 | 27 | 26 | 25 | 24 |
| – | – | – | – | – | – | – | – |
| 23 | 22 | 21 | 20 | 19 | 18 | 17 | 16 |
| – | – | – | – | – | – | – | – |
| 15 | 14 | 13 | 12 | 11 | 10 | 9 | 8 |
| – | – | – | – | – | – | – | – |
| 7 | 6 | 5 | 4 | 3 | 2 | 1 | 0 |
| CH7 | CH6 | CH5 | CH4 | CH3 | CH2 | CH1 | CH0 |

- CHn: Channel n Enable**
 Writing a one to these bits will set the corresponding bit in CHSR.
 Writing a zero to these bits has no effect.
 These bits always read a zero.

25.7.4 Channel Disable Register

Name: CHDR
Access Type: Write-only
Offset: 0x14
Reset Value: 0x00000000

| | | | | | | | |
|-----|-----|-----|-----|-----|-----|-----|-----|
| 31 | 30 | 29 | 28 | 27 | 26 | 25 | 24 |
| – | – | – | – | – | – | – | – |
| 23 | 22 | 21 | 20 | 19 | 18 | 17 | 16 |
| – | – | – | – | – | – | – | – |
| 15 | 14 | 13 | 12 | 11 | 10 | 9 | 8 |
| – | – | – | – | – | – | – | – |
| 7 | 6 | 5 | 4 | 3 | 2 | 1 | 0 |
| CH7 | CH6 | CH5 | CH4 | CH3 | CH2 | CH1 | CH0 |

- **CHn: Channel n Disable**

Writing a one to these bits will clear the corresponding bit in CHSR.
 Writing a zero to these bits has no effect.
 These bits always read a zero.

Warning: If the corresponding channel is disabled during a conversion or if it is disabled then reenabled during a conversion, its associated data and its corresponding EOC and OVRE flags in SR are unpredictable.

25.7.5 Channel Status Register

Name: CHSR
Access Type: Read-only
Offset: 0x18
Reset Value: 0x00000000

| | | | | | | | |
|-----|-----|-----|-----|-----|-----|-----|-----|
| 31 | 30 | 29 | 28 | 27 | 26 | 25 | 24 |
| – | – | – | – | – | – | – | – |
| 23 | 22 | 21 | 20 | 19 | 18 | 17 | 16 |
| – | – | – | – | – | – | – | – |
| 15 | 14 | 13 | 12 | 11 | 10 | 9 | 8 |
| – | – | – | – | – | – | – | – |
| 7 | 6 | 5 | 4 | 3 | 2 | 1 | 0 |
| CH7 | CH6 | CH5 | CH4 | CH3 | CH2 | CH1 | CH0 |

- **CHn: Channel n Status**

These bits are set when the corresponding bits in CHER is written to one.

These bits are cleared when the corresponding bits in CHDR is written to one.

1: The corresponding channel is enabled.

0: The corresponding channel is disabled.

25.7.6 Status Register

Name: SR
Access Type: Read-only
Offset: 0x1C
Reset Value: 0x000C0000

| | | | | | | | |
|-------|-------|-------|-------|--------|-------|-------|-------|
| 31 | 30 | 29 | 28 | 27 | 26 | 25 | 24 |
| – | – | – | – | – | – | – | – |
| 23 | 22 | 21 | 20 | 19 | 18 | 17 | 16 |
| – | – | – | – | RXBUFF | ENDRX | GOVRE | DRDY |
| 15 | 14 | 13 | 12 | 11 | 10 | 9 | 8 |
| OVRE7 | OVRE6 | OVRE5 | OVRE4 | OVRE3 | OVRE2 | OVRE1 | OVRE0 |
| 7 | 6 | 5 | 4 | 3 | 2 | 1 | 0 |
| EOC7 | EOC6 | EOC5 | EOC4 | EOC3 | EOC2 | EOC1 | EOC0 |

- RXBUFF: RX Buffer Full**
 This bit is set when the Buffer Full signal from the Peripheral DMA is active.
 This bit is cleared when the Buffer Full signal from the Receive Peripheral DMA is inactive.
- ENDRX: End of RX Buffer**
 This bit is set when the End Receive signal from the Peripheral DMA is active.
 This bit is cleared when the End Receive signal from the Peripheral DMA is inactive.
- GOVRE: General Overrun Error**
 This bit is set when a General Overrun Error has occurred.
 This bit is cleared when the SR register is read.
 1: At least one General Overrun Error has occurred since the last read of the SR register.
 0: No General Overrun Error occurred since the last read of the SR register.
- DRDY: Data Ready**
 This bit is set when a data has been converted and is available in the Lcdr register.
 This bit is cleared when the Lcdr register is read.
 0: No data has been converted since the last read of the Lcdr register.
 1: At least one data has been converted and is available in the Lcdr register.
- OVREn: Overrun Error n**
 These bits are set when an overrun error on the corresponding channel has occurred (if implemented).
 These bits are cleared when the SR register is read.
 0: No overrun error on the corresponding channel (if implemented) since the last read of SR.
 1: There has been an overrun error on the corresponding channel (if implemented) since the last read of SR.
- EOCn: End of Conversion n**
 These bits are set when the corresponding conversion is complete.
 These bits are cleared when the corresponding CDR or Lcdr registers are read.
 0: Corresponding analog channel (if implemented) is disabled, or the conversion is not finished.
 1: Corresponding analog channel (if implemented) is enabled and conversion is complete.

25.7.7 Last Converted Data Register

Name: LCDR
Access Type: Read-only
Offset: 0x20
Reset Value: 0x00000000

| | | | | | | | |
|------------|----|----|----|----|----|------------|----|
| 31 | 30 | 29 | 28 | 27 | 26 | 25 | 24 |
| – | – | – | – | – | – | – | – |
| 23 | 22 | 21 | 20 | 19 | 18 | 17 | 16 |
| – | – | – | – | – | – | – | – |
| 15 | 14 | 13 | 12 | 11 | 10 | 9 | 8 |
| – | – | – | – | – | – | LDATA[9:8] | |
| 7 | 6 | 5 | 4 | 3 | 2 | 1 | 0 |
| LDATA[7:0] | | | | | | | |

- **LDATA: Last Data Converted**

The analog-to-digital conversion data is placed into this register at the end of a conversion and remains until a new conversion is completed.

25.7.8 Interrupt Enable Register

Name: IER
Access Type: Write-only
Offset: 0x24
Reset Value: 0x00000000

| | | | | | | | |
|-------|-------|-------|-------|--------|-------|-------|-------|
| 31 | 30 | 29 | 28 | 27 | 26 | 25 | 24 |
| – | – | – | – | – | – | – | – |
| 23 | 22 | 21 | 20 | 19 | 18 | 17 | 16 |
| – | – | – | – | RXBUFF | ENDRX | GOVRE | DRDY |
| 15 | 14 | 13 | 12 | 11 | 10 | 9 | 8 |
| OVRE7 | OVRE6 | OVRE5 | OVRE4 | OVRE3 | OVRE2 | OVRE1 | OVRE0 |
| 7 | 6 | 5 | 4 | 3 | 2 | 1 | 0 |
| EOC7 | EOC6 | EOC5 | EOC4 | EOC3 | EOC2 | EOC1 | EOC0 |

Writing a zero to a bit in this register has no effect.

Writing a one to a bit in this register will set the corresponding bit in IMR.

25.7.9 Interrupt Disable Register

Name: IDR
Access Type: Write-only
Offset: 0x28
Reset Value: 0x00000000

| | | | | | | | |
|-------|-------|-------|-------|--------|-------|-------|-------|
| 31 | 30 | 29 | 28 | 27 | 26 | 25 | 24 |
| – | – | – | – | – | – | – | – |
| 23 | 22 | 21 | 20 | 19 | 18 | 17 | 16 |
| – | – | – | – | RXBUFF | ENDRX | GOVRE | DRDY |
| 15 | 14 | 13 | 12 | 11 | 10 | 9 | 8 |
| OVRE7 | OVRE6 | OVRE5 | OVRE4 | OVRE3 | OVRE2 | OVRE1 | OVRE0 |
| 7 | 6 | 5 | 4 | 3 | 2 | 1 | 0 |
| EOC7 | EOC6 | EOC5 | EOC4 | EOC3 | EOC2 | EOC1 | EOC0 |

Writing a zero to a bit in this register has no effect.

Writing a one to a bit in this register will clear the corresponding bit in IMR.

25.7.10 Interrupt Mask Register

Name: IMR
Access Type: Read-only
Offset: 0x2C
Reset Value: 0x00000000

| | | | | | | | |
|-------|-------|-------|-------|--------|-------|-------|-------|
| 31 | 30 | 29 | 28 | 27 | 26 | 25 | 24 |
| – | – | – | – | – | – | – | – |
| 23 | 22 | 21 | 20 | 19 | 18 | 17 | 16 |
| – | – | – | – | RXBUFF | ENDRX | GOVRE | DRDY |
| 15 | 14 | 13 | 12 | 11 | 10 | 9 | 8 |
| OVRE7 | OVRE6 | OVRE5 | OVRE4 | OVRE3 | OVRE2 | OVRE1 | OVRE0 |
| 7 | 6 | 5 | 4 | 3 | 2 | 1 | 0 |
| EOC7 | EOC6 | EOC5 | EOC4 | EOC3 | EOC2 | EOC1 | EOC0 |

0: The corresponding interrupt is disabled.

1: The corresponding interrupt is enabled.

A bit in this register is cleared when the corresponding bit in IDR is written to one.

A bit in this register is cleared when the corresponding bit in IER is written to one.

25.7.11 Channel Data Register

Name: CDRx
Access Type: Read-only
Offset: 0x2C-0x4C
Reset Value: 0x00000000

| | | | | | | | |
|-----------|----|----|----|----|----|-----------|----|
| 31 | 30 | 29 | 28 | 27 | 26 | 25 | 24 |
| – | – | – | – | – | – | – | – |
| 23 | 22 | 21 | 20 | 19 | 18 | 17 | 16 |
| – | – | – | – | – | – | – | – |
| 15 | 14 | 13 | 12 | 11 | 10 | 9 | 8 |
| – | – | – | – | – | – | DATA[9:8] | |
| 7 | 6 | 5 | 4 | 3 | 2 | 1 | 0 |
| DATA[7:0] | | | | | | | |

- **DATA: Converted Data**

The analog-to-digital conversion data is placed into this register at the end of a conversion and remains until a new conversion is completed. The Convert Data Register (CDR) is only loaded if the corresponding analog channel is enabled.

25.7.12 Version Register

Name: VERSION

Access Type: Read-only

Offset: 0xFC

Reset Value: –

| | | | | | | | |
|--------------|----|----|----|---------------|----|----|----|
| 31 | 30 | 29 | 28 | 27 | 26 | 25 | 24 |
| – | – | – | – | – | – | – | – |
| 23 | 22 | 21 | 20 | 19 | 18 | 17 | 16 |
| – | – | – | – | VARIANT | | | |
| 15 | 14 | 13 | 12 | 11 | 10 | 9 | 8 |
| – | – | – | – | VERSION[11:8] | | | |
| 7 | 6 | 5 | 4 | 3 | 2 | 1 | 0 |
| VERSION[7:0] | | | | | | | |

- **VARIANT: Variant Number**
Reserved. No functionality associated.
- **VERSION: Version Number**
Version number of the module. No functionality associated.

25.8 Module Configuration

The specific configuration for the ADC instance is listed in the following tables.

Table 25-3. Module configuration

| Feature | ADC |
|--------------------|---|
| Number of Channels | 8 |
| Internal Trigger 0 | TIOA Ouput A of the Timer Counter Channel 0 |
| Internal Trigger 1 | TIOB Ouput B of the Timer Counter Channel 0 |
| Internal Trigger 2 | TIOA Ouput A of the Timer Counter Channel 1 |
| Internal Trigger 3 | TIOB Ouput B of the Timer Counter Channel 1 |
| Internal Trigger 4 | TIOA Ouput A of the Timer Counter Channel 2 |
| Internal Trigger 5 | TIOB Ouput B of the Timer Counter Channel 2 |

Table 25-4. Module Clock Name

| Module name | Clock name |
|-------------|------------|
| ADC | CLK_ADC |

Table 25-5. Register Reset Values

| Module name | Reset Value |
|-------------|-------------|
| VERSION | 0x00000200 |

26. Audio Bitstream DAC (ABDAC)

Rev: 1.0.1.1

26.1 Features

- Digital Stereo DAC
- Oversampled D/A conversion architecture
 - Oversampling ratio fixed 128x
 - FIR equalization filter
 - Digital interpolation filter: Comb4
 - 3rd Order Sigma-Delta D/A converters
- Digital bitstream outputs
- Parallel interface
- Connected to DMA Controller for background transfer without CPU intervention

26.2 Overview

The Audio Bitstream DAC converts a 16-bit sample value to a digital bitstream with an average value proportional to the sample value. Two channels are supported, making the Audio Bitstream DAC particularly suitable for stereo audio. Each channel has a pair of complementary digital outputs, DATAn and DATANn, which can be connected to an external high input impedance amplifier.

The output DATAn and DATANn should be as ideal as possible before filtering, to achieve the best SNR and THD quality. The outputs can be connected to a class D amplifier output stage to drive a speaker directly, or it can be low pass filtered and connected to a high input impedance amplifier. A simple 1st order low pass filter that filters all the frequencies above 50kHz should be adequate when applying the signal to a speaker or a bandlimited amplifier, as the speaker or amplifier will act as a filter and remove high frequency components from the signal. In some cases high frequency components might be folded down into the audible range, and in that case a higher order filter is required. For performance measurements on digital equipment a minimum of 4th order low pass filter should be used. This is to prevent aliasing in the measurements.

For the best performance when not using a class D amplifier approach, the two outputs DATAn and DATANn, should be applied to a differential stage amplifier, as this will increase the SNR and THD.

26.3 Block Diagram

Figure 26-1. ABDAC Block Diagram

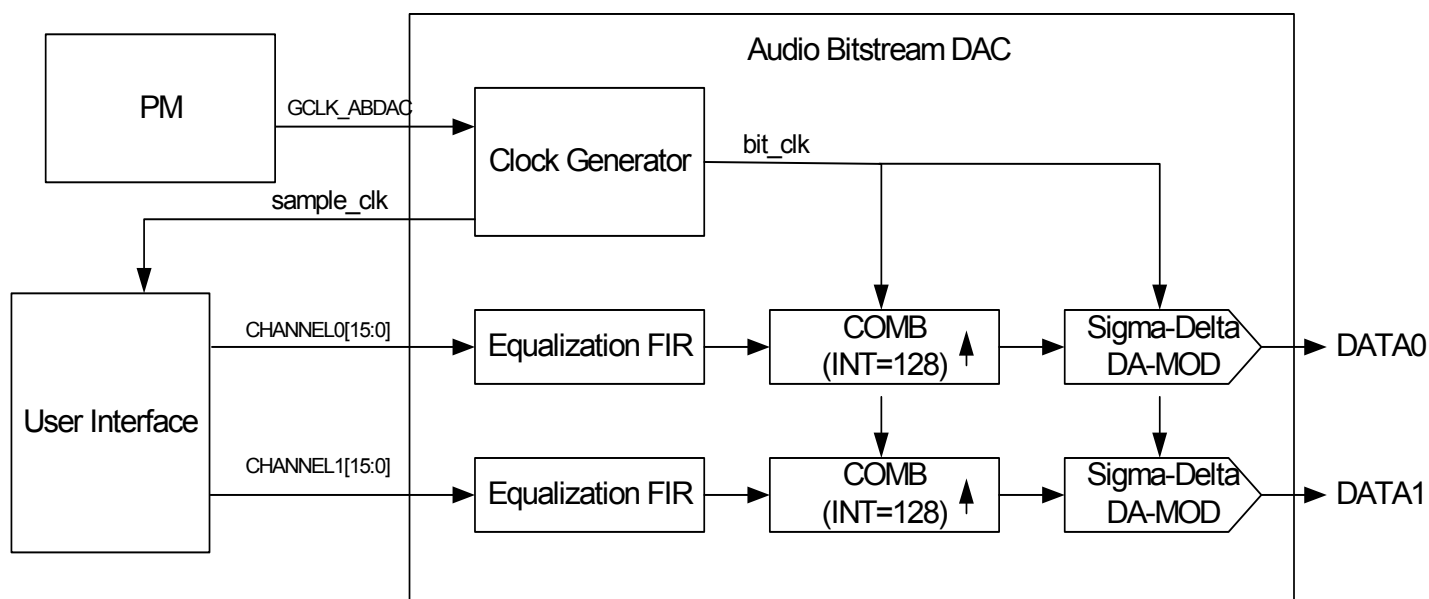

26.4 I/O Lines Description

Table 26-1. I/O Lines Description

| Pin Name | Pin Description | Type |
|----------|--|--------|
| DATA0 | Output from Audio Bitstream DAC Channel 0 | Output |
| DATA1 | Output from Audio Bitstream DAC Channel 1 | Output |
| DATAN0 | Inverted output from Audio Bitstream DAC Channel 0 | Output |
| DATAN1 | Inverted output from Audio Bitstream DAC Channel 1 | Output |

26.5 Product Dependencies

In order to use this module, other parts of the system must be configured correctly, as described below.

26.5.1 I/O Lines

The output pins used for the output bitstream from the Audio Bitstream DAC may be multiplexed with IO lines.

Before using the Audio Bitstream DAC, the I/O Controller must be configured in order for the Audio Bitstream DAC I/O lines to be in Audio Bitstream DAC peripheral mode.

26.5.2 Clocks

The CLK_ABDAC to the Audio Bitstream DAC is generated by the Power Manager (PM). Before using the Audio Bitstream DAC, the user must ensure that the Audio Bitstream DAC clock is enabled in the Power Manager.

The ABDAC needs a separate clock for the D/A conversion operation. This clock, GCLK_ABDAC should be set up in the Generic Clock register in the Power Manager and its frequency must be as follow:

$$f_{GCLK} = 256 \times f_s$$

where f_s is the sampling rate of the data stream to convert. For $f_s = 48\text{kHz}$ this means that the GCLK_ABDAC clock must have a frequency of 12.288MHz.

The two clocks, CLK_ABDAC and GCLK_ABDAC, must be in phase with each other.

26.5.3 Interrupts

The ABDAC interrupt request line is connected to the interrupt controller. Using the ABDAC interrupt requires the interrupt controller to be programmed first.

26.6 Functional Description

26.6.1 How to Initialize the Module

In order to use the Audio Bitstream DAC the product dependencies given in [Section 26.5 on page 561](#) must be resolved. Particular attention should be given to the configuration of clocks and I/O lines in order to ensure correct operation of the Audio Bitstream DAC.

The Audio Bitstream DAC is enabled by writing a one to the enable bit in the Audio Bitstream DAC Control Register (CR.EN).

The Transmit Ready Interrupt Status bit in the Interrupt Status Register (ISR.TXREADY) will be set whenever the ABDAC is ready to receive a new sample. A new sample value should be written to SDR before 256 ABDAC clock cycles, or an underrun will occur, as indicated by the Underrun Interrupt Status bit in ISR (ISR.UNDERRUN). ISR is cleared when read, or when writing one to the corresponding bits in the Interrupt Clear Register (ICR).

26.6.2 Data Format

The input data format is two's complement. Two 16-bit sample values for channel 0 and 1 can be written to the least and most significant halfword of the Sample Data Register (SDR), respectively.

An input value of 0x7FFF will result in an output voltage of approximately:

$$V_{OUT}(0x7FFF) \approx \frac{38}{128} \cdot V_{DDIO} = \frac{38}{128} \cdot 3,3 \approx 0,98V$$

An Input value of 0x8000 will result in an output value of approximately:

$$V_{OUT}(0x8000) \approx \frac{90}{128} \cdot V_{DDIO} = \frac{90}{128} \cdot 3,3 \approx 2,32V$$

If one want to get coherence between the sign of the input data and the output voltage one can use the DATAN signal or invert the sign of the input data by software.

26.6.3 Data Swapping

When the SWAP bit in the ABDAC Control Register (CR.SWAP) is written to one, writing to the Sample Data Register (SDR) will cause the values written to the CHANNEL0 and CHANNEL1 fields to be swapped.

26.6.4 Peripheral DMA Controller

The Audio Bitstream DAC is connected to the Peripheral DMA Controller. The Peripheral DMA Controller can be programmed to automatically transfer samples to the Audio Bitstream DAC Sample Data Register (SDR) when the Audio Bitstream DAC is ready for new samples. In this case only the CR.EN bit needs to be set in the Audio Bitstream DAC module. This enables the Audio Bitstream DAC to operate without any CPU intervention such as polling the Interrupt Status Register (ISR) or using interrupts. See the Peripheral DMA Controller documentation for details on how to setup Peripheral DMA transfers.

26.6.5 Construction

The Audio Bitstream DAC is constructed of two 3rd order Sigma-Delta D/A converter with an oversampling ratio of 128. The samples are upsampled with a 4th order Sinc interpolation filter (Comb4) before being applied to the Sigma-Delta Modulator. In order to compensate for the pass band frequency response of the interpolation filter and flatten the overall frequency response, the input to the interpolation filter is first filtered with a simple 3-tap FIR filter. The total frequency response of the Equalization FIR filter and the interpolation filter is given in [Figure 26-2 on page 564](#). The digital output bitstreams from the Sigma-Delta Modulators should be low-pass filtered to remove high frequency noise inserted by the modulation process.

26.6.6 Equalization Filter

The equalization filter is a simple 3-tap FIR filter. The purpose of this filter is to compensate for the pass band frequency response of the sinc interpolation filter. The equalization filter makes the pass band response more flat and moves the -3dB corner a little higher.

26.6.7 Interpolation Filter

The interpolation filter interpolates from f_s to $128f_s$. This filter is a 4th order Cascaded Integrator-Comb filter, and the basic building blocks of this filter is a comb part and an integrator part.

26.6.8 Sigma-Delta Modulator

This part is a 3rd order Sigma-Delta Modulator consisting of three differentiators (delta blocks), three integrators (sigma blocks) and a one bit quantizer. The purpose of the integrators is to shape the noise, so that the noise is reduced in the band of interest and increased at the higher frequencies, where it can be filtered.

26.6.9 Frequency Response

Figure 26-2. Frequency Response, EQ-FIR+COMB⁴

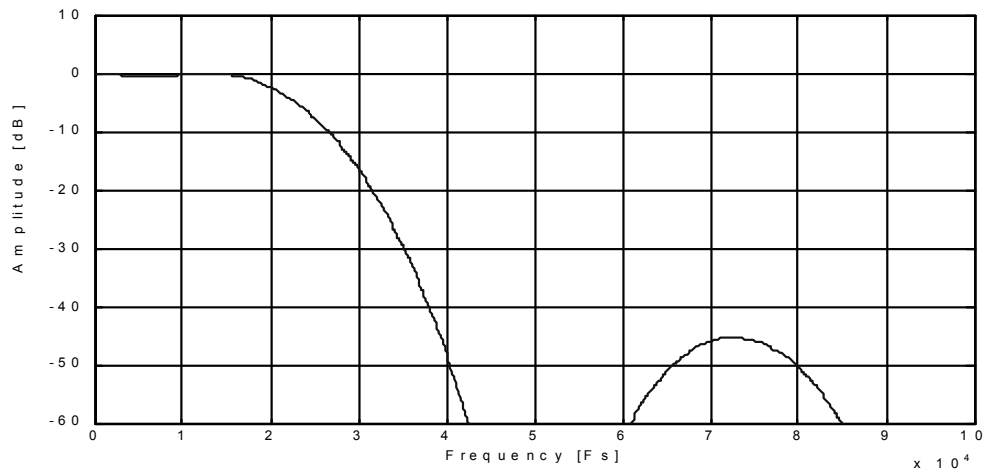

26.7 User Interface

Table 26-2. ABDAC Register Memory Map

| Offset | Register | Register Name | Access | Reset |
|--------|----------------------------|---------------|------------|------------|
| 0x00 | Sample Data Register | SDR | Read/Write | 0x00000000 |
| 0x08 | Control Register | CR | Read/Write | 0x00000000 |
| 0x0C | Interrupt Mask Register | IMR | Read-only | 0x00000000 |
| 0x10 | Interrupt Enable Register | IER | Write-only | 0x00000000 |
| 0x14 | Interrupt Disable Register | IDR | Write-only | 0x00000000 |
| 0x18 | Interrupt Clear Register | ICR | Write-only | 0x00000000 |
| 0x1C | Interrupt Status Register | ISR | Read-only | 0x00000000 |

26.7.1 Sample Data Register

Name: SDR
Access Type: Read/Write
Offset: 0x00
Reset Value: 0x00000000

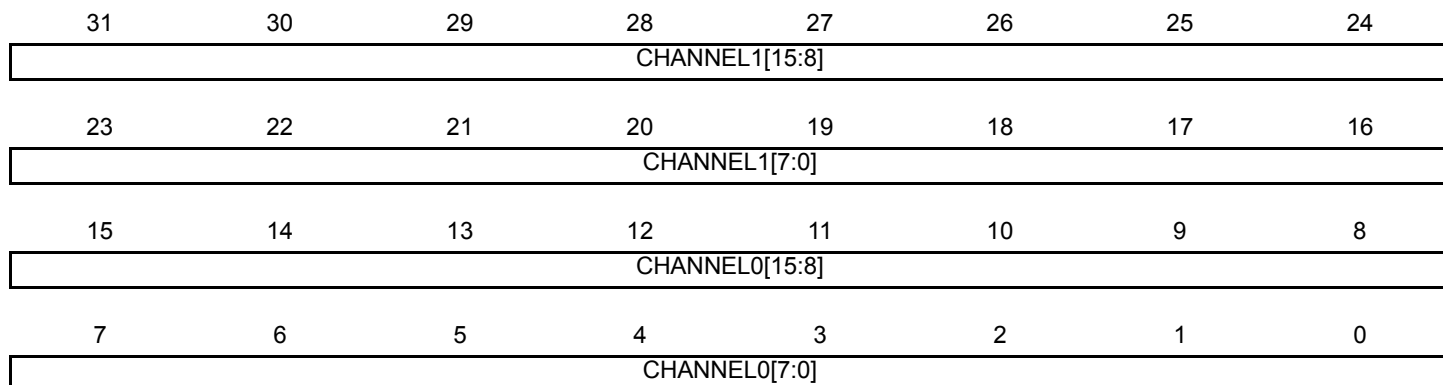

- CHANNEL1: Sample Data for Channel 1**
 signed 16-bit Sample Data for channel 1.
- CHANNEL0: Signed 16-bit Sample Data for Channel 0**
 signed 16-bit Sample Data for channel 0.

26.7.2 Control Register

Name: CR
Access Type: Read/Write
Offset: 0x08
Reset Value: 0x00000000

| | | | | | | | |
|----|------|----|----|----|----|----|----|
| 31 | 30 | 29 | 28 | 27 | 26 | 25 | 24 |
| EN | SWAP | - | - | - | - | - | - |
| 23 | 22 | 21 | 20 | 19 | 18 | 17 | 16 |
| - | - | - | - | - | - | - | - |
| 15 | 14 | 13 | 12 | 11 | 10 | 9 | 8 |
| - | - | - | - | - | - | - | - |
| 7 | 6 | 5 | 4 | 3 | 2 | 1 | 0 |
| - | - | - | - | - | - | - | - |

- **EN: Enable Audio Bitstream DAC**
 - 1: The module is enabled.
 - 0: The module is disabled.
- **SWAP: Swap Channels**
 - 1: The swap of CHANNEL0 and CHANNEL1 samples is enabled.
 - 0: The swap of CHANNEL0 and CHANNEL1 samples is disabled.

26.7.3 Interrupt Mask Register

Name: IMR
Access Type: Read-only
Offset: 0x0C
Reset Value: 0x00000000

| | | | | | | | |
|----|----|---------|----------|----|----|----|----|
| 31 | 30 | 29 | 28 | 27 | 26 | 25 | 24 |
| - | - | TXREADY | UNDERRUN | - | - | - | - |
| 23 | 22 | 21 | 20 | 19 | 18 | 17 | 16 |
| - | - | - | - | - | - | - | - |
| 15 | 14 | 13 | 12 | 11 | 10 | 9 | 8 |
| - | - | - | - | - | - | - | - |
| 7 | 6 | 5 | 4 | 3 | 2 | 1 | 0 |
| - | - | - | - | - | - | - | - |

1: The corresponding interrupt is enabled.

0: The corresponding interrupt is disabled.

A bit in this register is set when the corresponding bit in IER is written to one.

A bit in this register is cleared when the corresponding bit in IDR is written to one.

26.7.4 Interrupt Enable Register

Name: IER
Access Type: Write-only
Offset: 0x10
Reset Value: 0x00000000

| | | | | | | | |
|----|----|---------|----------|----|----|----|----|
| 31 | 30 | 29 | 28 | 27 | 26 | 25 | 24 |
| - | - | TXREADY | UNDERRUN | - | - | - | - |
| 23 | 22 | 21 | 20 | 19 | 18 | 17 | 16 |
| - | - | - | - | - | - | - | - |
| 15 | 14 | 13 | 12 | 11 | 10 | 9 | 8 |
| - | - | - | - | - | - | - | - |
| 7 | 6 | 5 | 4 | 3 | 2 | 1 | 0 |
| - | - | - | - | - | - | - | - |

Writing a one to a bit in this register will set the corresponding bit in IMR.
 Writing a zero to a bit in this register has no effect.

26.7.5 Interrupt Disable Register

Name: IDR
Access Type: Write-only
Offset: 0x14
Reset Value: 0x00000000

| | | | | | | | |
|----|----|---------|----------|----|----|----|----|
| 31 | 30 | 29 | 28 | 27 | 26 | 25 | 24 |
| - | - | TXREADY | UNDERRUN | - | - | - | - |
| 23 | 22 | 21 | 20 | 19 | 18 | 17 | 16 |
| - | - | - | - | - | - | - | - |
| 15 | 14 | 13 | 12 | 11 | 10 | 9 | 8 |
| - | - | - | - | - | - | - | - |
| 7 | 6 | 5 | 4 | 3 | 2 | 1 | 0 |
| - | - | - | - | - | - | - | - |

Writing a one to a bit in this register will clear the corresponding bit in IMR.
 Writing a zero to a bit in this register has no effect.

26.7.6 Interrupt Clear Register

Name: ICR
Access Type: Write-only
Offset: 0x18
Reset Value: 0x00000000

| | | | | | | | |
|----|----|---------|----------|----|----|----|----|
| 31 | 30 | 29 | 28 | 27 | 26 | 25 | 24 |
| - | - | TXREADY | UNDERRUN | - | - | - | - |
| 23 | 22 | 21 | 20 | 19 | 18 | 17 | 16 |
| - | - | - | - | - | - | - | - |
| 15 | 14 | 13 | 12 | 11 | 10 | 9 | 8 |
| - | - | - | - | - | - | - | - |
| 7 | 6 | 5 | 4 | 3 | 2 | 1 | 0 |
| - | - | - | - | - | - | - | - |

Writing a one to a bit in this register will clear the corresponding bit in ISR and the corresponding interrupt request.
 Writing a zero to a bit in this register has no effect.

26.7.7 Interrupt Status Register

Name: ISR
Access Type: Read-only
Offset: 0x1C
Reset Value: 0x00000000

| | | | | | | | |
|----|----|---------|----------|----|----|----|----|
| 31 | 30 | 29 | 28 | 27 | 26 | 25 | 24 |
| - | - | TXREADY | UNDERRUN | - | - | - | - |
| 23 | 22 | 21 | 20 | 19 | 18 | 17 | 16 |
| - | - | - | - | - | - | - | - |
| 15 | 14 | 13 | 12 | 11 | 10 | 9 | 8 |
| - | - | - | - | - | - | - | - |
| 7 | 6 | 5 | 4 | 3 | 2 | 1 | 0 |
| - | - | - | - | - | - | - | - |

- **TXREADY: TX Ready Interrupt Status**

This bit is set when the Audio Bitstream DAC is ready to receive a new data in SDR.

This bit is cleared when the Audio Bitstream DAC is not ready to receive a new data in SDR.

- **UNDERRUN: Underrun Interrupt Status**

This bit is set when at least one Audio Bitstream DAC Underrun has occurred since the last time this bit was cleared (by reset or by writing in ICR).

This bit is cleared when no Audio Bitstream DAC Underrun has occurred since the last time this bit was cleared (by reset or by writing in ICR).

27. Programming and Debugging

27.1 Overview

General description of programming and debug features, block diagram and introduction of main concepts.

27.2 Service Access Bus

The AVR32 architecture offers a common interface for access to On-Chip Debug, programming, and test functions. These are mapped on a common bus called the Service Access Bus (SAB), which is linked to the JTAG port through a bus master module, which also handles synchronization between the debugger and SAB clocks.

When accessing the SAB through the debugger there are no limitations on debugger frequency compared to chip frequency, although there must be an active system clock in order for the SAB accesses to complete. If the system clock is switched off in sleep mode, activity on the debugger will restart the system clock automatically, without waking the device from sleep. Debuggers may optimize the transfer rate by adjusting the frequency in relation to the system clock. This ratio can be measured with debug protocol specific instructions.

The Service Access Bus uses 36 address bits to address memory or registers in any of the slaves on the bus. The bus supports sized accesses of bytes (8 bits), halfwords (16 bits), or words (32 bits). All accesses must be aligned to the size of the access, i.e. halfword accesses must have the lowest address bit cleared, and word accesses must have the two lowest address bits cleared.

27.2.1 SAB address map

The Service Access Bus (SAB) gives the user access to the internal address space and other features through a 36 bits address space. The 4 MSBs identify the slave number, while the 32 LSBs are decoded within the slave's address space. The SAB slaves are shown in [Table 27-1 on page 573](#).

Table 27-1. SAB Slaves, addresses and descriptions.

| Slave | Address [35:32] | Description |
|---------------------|-----------------|---|
| Unallocated | 0x0 | Intentionally unallocated |
| OCD | 0x1 | OCD registers |
| HSB | 0x4 | HSB memory space, as seen by the CPU |
| HSB | 0x5 | Alternative mapping for HSB space, for compatibility with other 32-bit AVR devices. |
| Memory Service Unit | 0x6 | Memory Service Unit registers |
| Reserved | Other | Unused |

27.2.2 SAB security restrictions

The Service Access bus can be restricted by internal security measures. A short description of the security measures are found in the table below.

27.2.2.1 Security measure and control location

A security measure is a mechanism to either block or allow SAB access to a certain address or address range. A security measure is enabled or disabled by one or several control signals. This is called the control location for the security measure.

These security measures can be used to prevent an end user from reading out the code programmed in the flash, for instance.

Table 27-2. SAB Security measures.

| Security measure | Control Location | Description |
|-----------------------|---------------------------------|--|
| Security bit | FLASHC security bit set | Programming and debugging not possible, very restricted access. |
| User code programming | FLASHC UPROT + security bit set | Restricts all access except parts of the flash and the flash controller for programming user code. Debugging is not possible unless an OS running from the secure part of the flash supports it. |

Below follows a more in depth description of what locations are accessible when the security measures are active.

Table 27-3. Security bit SAB restrictions

| Name | Address start | Address end | Access |
|--------------------------------------|---------------|-------------|------------|
| OCD DCCPU, OCD DCEMU, OCD DCSR | 0x100000110 | 0x100000118 | Read/Write |
| User page | 0x580800000 | 0x581000000 | Read |
| Other accesses | - | - | Blocked |

Table 27-4. User code programming SAB restrictions

| Name | Address start | Address end | Access |
|--------------------------------------|-----------------------------|--------------------------|------------|
| OCD DCCPU, OCD DCEMU, OCD DCSR | 0x100000110 | 0x100000118 | Read/Write |
| User page | 0x580800000 | 0x581000000 | Read |
| FLASHC PB interface | 0x5FFFE0000 | 0x5FFFE0400 | Read/Write |
| FLASH pages outside BOOTPROT | 0x580000000 + BOOTPROT size | 0x580000000 + Flash size | Read/Write |
| Other accesses | - | - | Blocked |

27.3 On-Chip Debug (OCD)

Rev: 1.4.3.1

27.3.1 Features

- Debug interface in compliance with IEEE-ISTO 5001-2003 (Nexus 2.0) Class 2+
- JTAG access to all on-chip debug functions
- Advanced program, data, ownership, and watchpoint trace supported
- NanoTrace JTAG-based trace access
- Auxiliary port for high-speed trace information
- Hardware support for 6 program and 2 data breakpoints
- Unlimited number of software breakpoints supported
- Automatic CRC check of memory regions

27.3.2 Overview

Debugging on the AT32UC3B is facilitated by a powerful On-Chip Debug (OCD) system. The user accesses this through an external debug tool which connects to the JTAG port and the Auxiliary (AUX) port. The AUX port is primarily used for trace functions, and a JTAG-based debugger is sufficient for basic debugging.

The debug system is based on the Nexus 2.0 standard, class 2+, which includes:

- Basic run-time control
- Program breakpoints
- Data breakpoints
- Program trace
- Ownership trace
- Data trace

In addition to the mandatory Nexus debug features, the AT32UC3B implements several useful OCD features, such as:

- Debug Communication Channel between CPU and JTAG
- Run-time PC monitoring
- CRC checking
- NanoTrace
- Software Quality Assurance (SQA) support

The OCD features are controlled by OCD registers, which can be accessed by JTAG when the NEXUS_ACCESS JTAG instruction is loaded. The CPU can also access OCD registers directly using mtdr/mfdr instructions in any privileged mode. The OCD registers are implemented based on the recommendations in the Nexus 2.0 standard, and are detailed in the AVR32UC Technical Reference Manual.

27.3.3 Block Diagram

Figure 27-1. On-Chip Debug Block Diagram

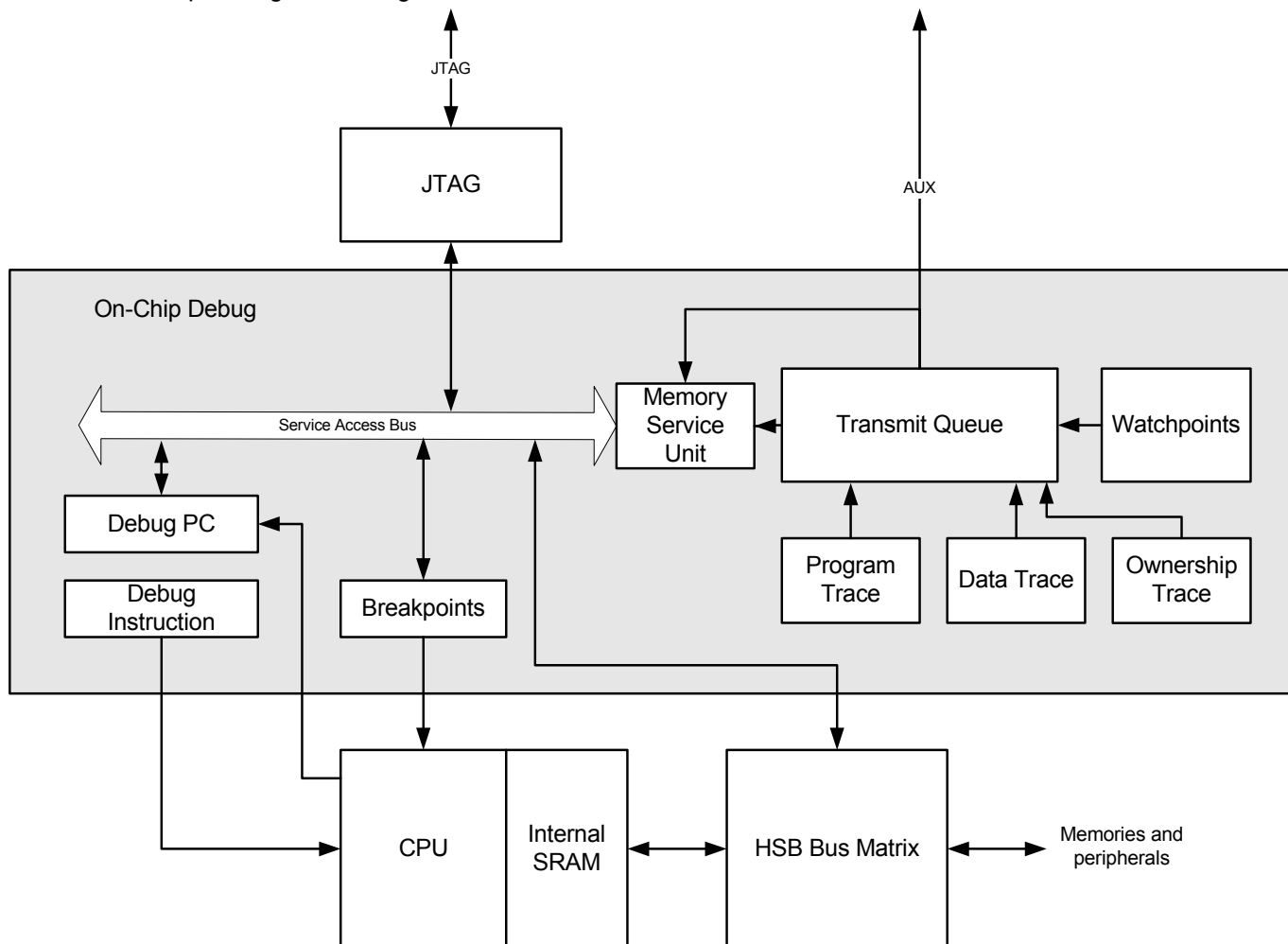

27.3.4 JTAG-based Debug Features

A debugger can control all OCD features by writing OCD registers over the JTAG interface. Many of these do not depend on output on the AUX port, allowing a JTAG-based debugger to be used.

A JTAG-based debugger should connect to the device through a standard 10-pin IDC connector as described in the AVR32UC Technical Reference Manual.

Figure 27-2. JTAG-based Debugger

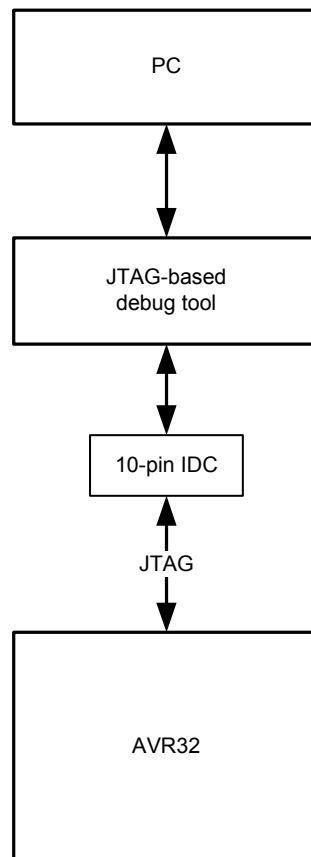

27.3.4.1 *Debug Communication Channel*

The Debug Communication Channel (DCC) consists of a pair of OCD registers with associated handshake logic, accessible to both CPU and JTAG. The registers can be used to exchange data between the CPU and the JTAG master, both runtime as well as in debug mode.

27.3.4.2 *breakpoints*

One of the most fundamental debug features is the ability to halt the CPU, to examine registers and the state of the system. This is accomplished by breakpoints, of which many types are available:

- Unconditional breakpoints are set by writing OCD registers by JTAG, halting the CPU immediately.
- Program breakpoints halt the CPU when a specific address in the program is executed.
- Data breakpoints halt the CPU when a specific memory address is read or written, allowing variables to be watched.
- Software breakpoints halt the CPU when the breakpoint instruction is executed.

When a breakpoint triggers, the CPU enters debug mode, and the D bit in the Status Register is set. This is a privileged mode with dedicated return address and return status registers. All privileged instructions are permitted. Debug mode can be entered as either OCD mode, running instructions from JTAG, or monitor mode, running instructions from program memory.

27.3.4.3 *OCD mode*

When a breakpoint triggers, the CPU enters OCD mode, and instructions are fetched from the Debug Instruction OCD register. Each time this register is written by JTAG, the instruction is executed, allowing the JTAG to execute CPU instructions directly. The JTAG master can e.g. read out the register file by issuing mtdr instructions to the CPU, writing each register to the Debug Communication Channel OCD registers.

27.3.4.4 *monitor mode*

Since the OCD registers are directly accessible by the CPU, it is possible to build a software-based debugger that runs on the CPU itself. Setting the Monitor Mode bit in the Development Control register causes the CPU to enter monitor mode instead of OCD mode when a breakpoint triggers. Monitor mode is similar to OCD mode, except that instructions are fetched from the debug exception vector in regular program memory, instead of issued by JTAG.

27.3.4.5 *program counter monitoring*

Normally, the CPU would need to be halted for a JTAG-based debugger to examine the current PC value. However, the AT32UC3B provides a Debug Program Counter OCD register, where the debugger can continuously read the current PC without affecting the CPU. This allows the debugger to generate a simple statistic of the time spent in various areas of the code, easing code optimization.

27.3.5 **Memory Service Unit**

The Memory Service Unit (MSU) is a block dedicated to test and debug functionality. It is controlled through a dedicated set of registers addressed through the MEMORY_SERVICE JTAG command.

27.3.5.1 *Cyclic Redundancy Check (CRC)*

The MSU can be used to automatically calculate the CRC of a block of data in memory. The OCD will then read out each word in the specified memory block and report the CRC32-value in an OCD register.

27.3.5.2 *NanoTrace*

The MSU additionally supports NanoTrace. This is an AVR32-specific feature, in which trace data is output to memory instead of the AUX port. This allows the trace data to be extracted by JTAG MEMORY_ACCESS, enabling trace features for JTAG-based debuggers. The user must write MSU registers to configure the address and size of the memory block to be used for NanoTrace. The NanoTrace buffer can be anywhere in the physical address range, including internal and external RAM, through an EBI, if present. This area may not be used by the application running on the CPU.

27.3.6 **AUX-based Debug Features**

Utilizing the Auxiliary (AUX) port gives access to a wide range of advanced debug features. Of prime importance are the trace features, which allow an external debugger to receive continuous information on the program execution in the CPU. Additionally, Event In and Event Out pins allow external events to be correlated with the program flow.

The AUX port contains a number of pins, as shown in [Table 27-5 on page 579](#). These are multiplexed with I/O Controller lines, and must explicitly be enabled by writing OCD registers before the debug session starts. The AUX port is mapped to two different locations, selectable by OCD Registers, minimizing the chance that the AUX port will need to be shared with an application.

Debug tools utilizing the AUX port should connect to the device through a Nexus-compliant Micror-38 connector, as described in the AVR32UC Technical Reference manual. This connector includes the JTAG signals and the RESET_N pin, giving full access to the programming and debug features in the device.

Table 27-5. Auxiliary Port Signals

| Signal | Direction | Description |
|-----------|-----------|-------------------------|
| MCKO | Output | Trace data output clock |
| MDO[5:0] | Output | Trace data output |
| MSEO[1:0] | Output | Trace frame control |
| EVTI_N | Input | Event In |
| EVTO_N | Output | Event Out |

Figure 27-3. AUX+JTAG based Debugger

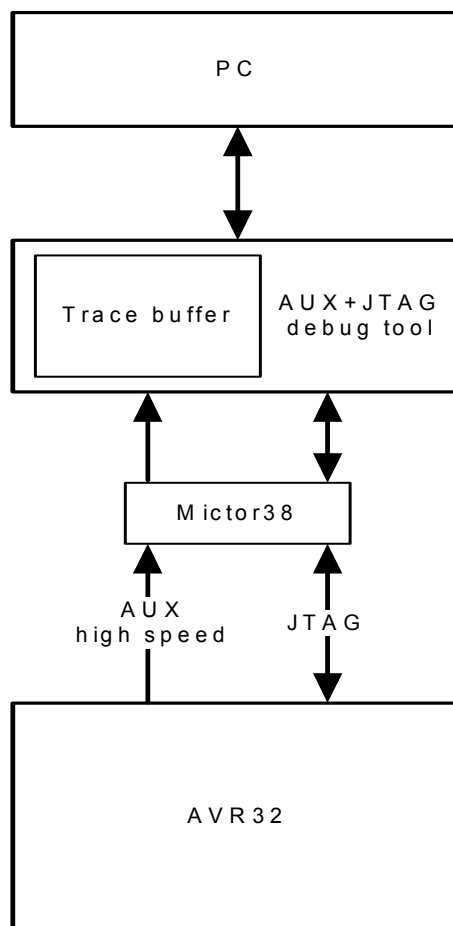

27.3.6.1 trace operation

Trace features are enabled by writing OCD registers by JTAG. The OCD extracts the trace information from the CPU, compresses this information and formats it into variable-length messages according to the Nexus standard. The messages are buffered in a 16-frame transmit queue, and are output on the AUX port one frame at a time.

The trace features can be configured to be very selective, to reduce the bandwidth on the AUX port. In case the transmit queue overflows, error messages are produced to indicate loss of data. The transmit queue module can optionally be configured to halt the CPU when an overflow occurs, to prevent the loss of messages, at the expense of longer run-time for the program.

27.3.6.2 *program trace*

Program trace allows the debugger to continuously monitor the program execution in the CPU. Program trace messages are generated for every branch in the program, and contains compressed information, which allows the debugger to correlate the message with the source code to identify the branch instruction and target address.

27.3.6.3 *data trace*

Data trace outputs a message every time a specific location is read or written. The message contains information about the type (read/write) and size of the access, as well as the address and data of the accessed location. The AT32UC3B contains two data trace channels, each of which are controlled by a pair of OCD registers which determine the range of addresses (or single address) which should produce data trace messages.

27.3.6.4 *ownership trace*

Program and data trace operate on virtual addresses. In cases where an operating system runs several processes in overlapping virtual memory segments, the Ownership Trace feature can be used to identify the process switch. When the O/S activates a process, it will write the process ID number to an OCD register, which produces an Ownership Trace Message, allowing the debugger to switch context for the subsequent program and data trace messages. As the use of this feature depends on the software running on the CPU, it can also be used to extract other types of information from the system.

27.3.6.5 *watchpoint messages*

The breakpoint modules normally used to generate program and data breakpoints can also be used to generate Watchpoint messages, allowing a debugger to monitor program and data events without halting the CPU. Watchpoints can be enabled independently of breakpoints, so a breakpoint module can optionally halt the CPU when the trigger condition occurs. Data trace modules can also be configured to produce watchpoint messages instead of regular data trace messages.

27.3.6.6 *Event In and Event Out pins*

The AUX port also contains an Event In pin (EVTI_N) and an Event Out pin (EVTO_N). EVTI_N can be used to trigger a breakpoint when an external event occurs. It can also be used to trigger specific program and data trace synchronization messages, allowing an external event to be correlated to the program flow.

When the CPU enters debug mode, a Debug Status message is transmitted on the trace port. All trace messages can be timestamped when they are received by the debug tool. However, due to the latency of the transmit queue buffering, the timestamp will not be 100% accurate. To improve this, EVTO_N can toggle every time a message is inserted into the transmit queue, allowing trace messages to be timestamped precisely. EVTO_N can also toggle when a breakpoint module triggers, or when the CPU enters debug mode, for any reason. This can be used to measure precisely when the respective internal event occurs.

27.3.6.7 Software Quality Analysis (SQA)

Software Quality Analysis (SQA) deals with two important issues regarding embedded software development. *Code coverage* involves identifying untested parts of the embedded code, to improve test procedures and thus the quality of the released software. *Performance analysis* allows the developer to precisely quantify the time spent in various parts of the code, allowing bottlenecks to be identified and optimized.

Program trace must be used to accomplish these tasks without instrumenting (altering) the code to be examined. However, traditional program trace cannot reconstruct the current PC value without correlating the trace information with the source code, which cannot be done on-the-fly. This limits program trace to a relatively short time segment, determined by the size of the trace buffer in the debug tool.

The OCD system in AT32UC3B extends program trace with SQA capabilities, allowing the debug tool to reconstruct the PC value on-the-fly. Code coverage and performance analysis can thus be reported for an unlimited execution sequence.

27.4 JTAG and Boundary-scan (JTAG)

Rev: 2.0.1.4

27.4.1 Features

- IEEE1149.1 compliant JTAG Interface
- Boundary-scan Chain for board-level testing
- Direct memory access and programming capabilities through JTAG Interface

27.4.2 Overview

The JTAG Interface offers a four pin programming and debug solution, including boundary-scan support for board-level testing.

[Figure 27-4 on page 583](#) shows how the JTAG is connected in an 32-bit AVR device. The TAP Controller is a state machine controlled by the TCK and TMS signals. The TAP Controller selects either the JTAG Instruction Register or one of several Data Registers as the scan chain (shift register) between the TDI-input and TDO-output.

The Instruction Register holds JTAG instructions controlling the behavior of a Data Register. The Device Identification Register, Bypass Register, and the boundary-scan chain are the Data Registers used for board-level testing. The Reset Register can be used to keep the device reset during test or programming.

The Service Access Bus (SAB) interface contains address and data registers for the Service Access Bus, which gives access to On-Chip Debug, programming, and other functions in the device. The SAB offers several modes of access to the address and data registers, as described in [Section 27.4.11](#).

[Section 27.5](#) lists the supported JTAG instructions, with references to the description in this document.

27.4.3 Block Diagram

Figure 27-4. JTAG and Boundary-scan Access

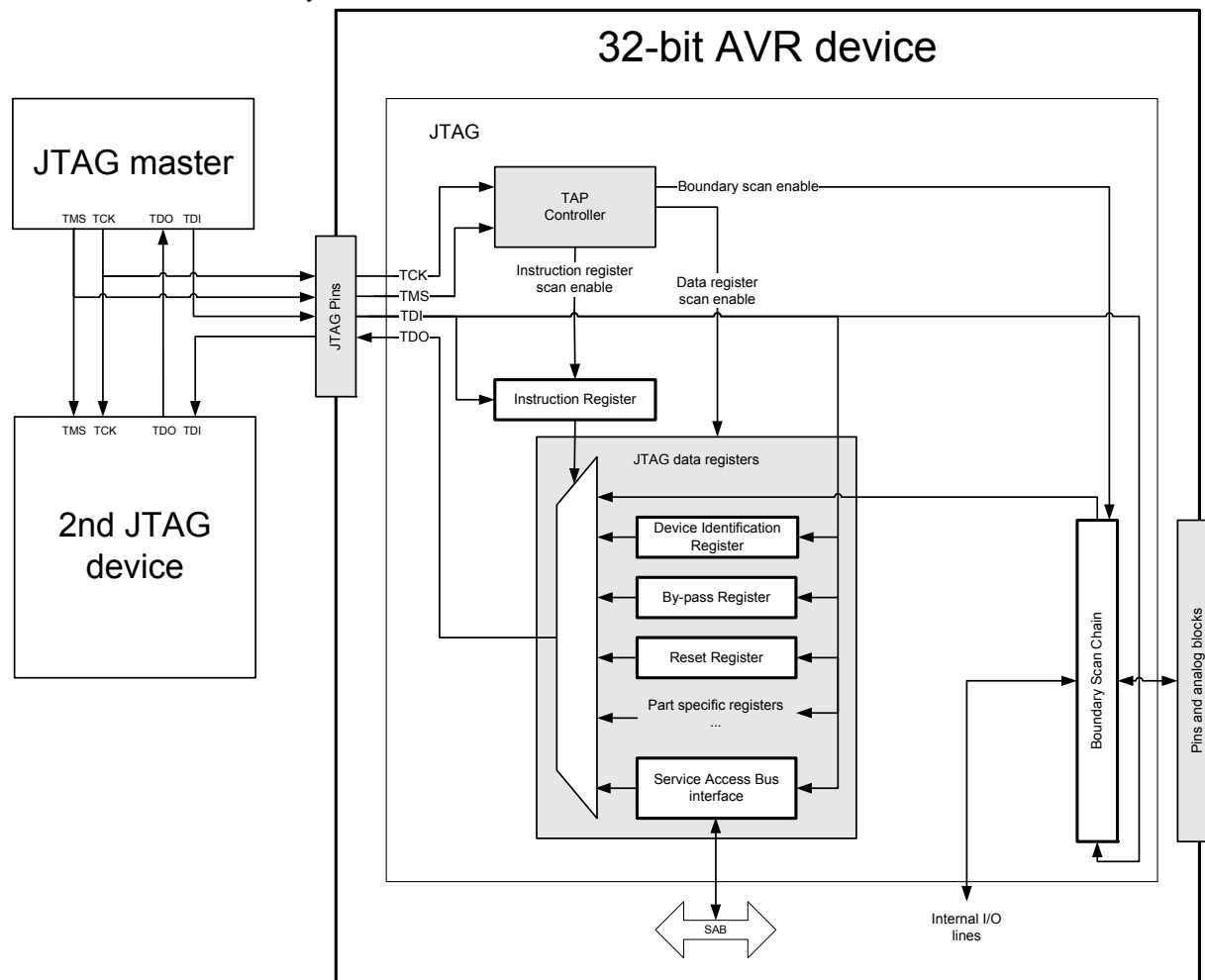

27.4.4 I/O Lines Description

Table 27-6. I/O Line Description

| Pin Name | Pin Description | Type | Active Level |
|----------|---|--------|--------------|
| TCK | Test Clock Input. Fully asynchronous to system clock frequency. | Input | |
| TMS | Test Mode Select, sampled on rising TCK. | Input | |
| TDI | Test Data In, sampled on rising TCK. | Input | |
| TDO | Test Data Out, driven on falling TCK. | Output | |

27.4.5 Product Dependencies

In order to use this module, other parts of the system must be configured correctly, as described below.

27.4.5.1 I/O Lines

The TMS, TDI, and TDO pins are multiplexed with I/O lines. When the JTAG is used the associated pins must be enabled. To enable the JTAG pins, refer to [Section 27.4.7](#).

While using the multiplexed JTAG lines all normal peripheral activity on these lines is disabled. The user must make sure that no external peripheral is blocking the JTAG lines while debugging.

27.4.5.2 *Power Management*

When an instruction that accesses the SAB is loaded in the instruction register, before entering a sleep mode, the system clocks are not switched off to allow debugging in sleep modes. This can lead to a program behaving differently when debugging.

27.4.5.3 *Clocks*

The JTAG Interface uses the external TCK pin as clock source. This clock must be provided by the JTAG master.

Instructions that use the SAB bus requires the internal main clock to be running.

27.4.6 **JTAG Interface**

The JTAG Interface is accessed through the dedicated JTAG pins shown in [Table 27-6 on page 583](#). The TMS control line navigates the TAP controller, as shown in [Figure 27-5 on page 585](#). The TAP controller manages the serial access to the JTAG Instruction and Data registers. Data is scanned into the selected instruction or data register on TDI, and out of the register on TDO, in the Shift-IR and Shift-DR states, respectively. The LSB is shifted in and out first. TDO is high-Z in other states than Shift-IR and Shift-DR.

The device implements a 5-bit Instruction Register (IR). A number of public JTAG instructions defined by the JTAG standard are supported, as described in [Section 27.5.2](#), as well as a number of 32-bit AVR-specific private JTAG instructions described in [Section 27.5.3](#). Each instruction selects a specific data register for the Shift-DR path, as described for each instruction.

Figure 27-5. TAP Controller State Diagram

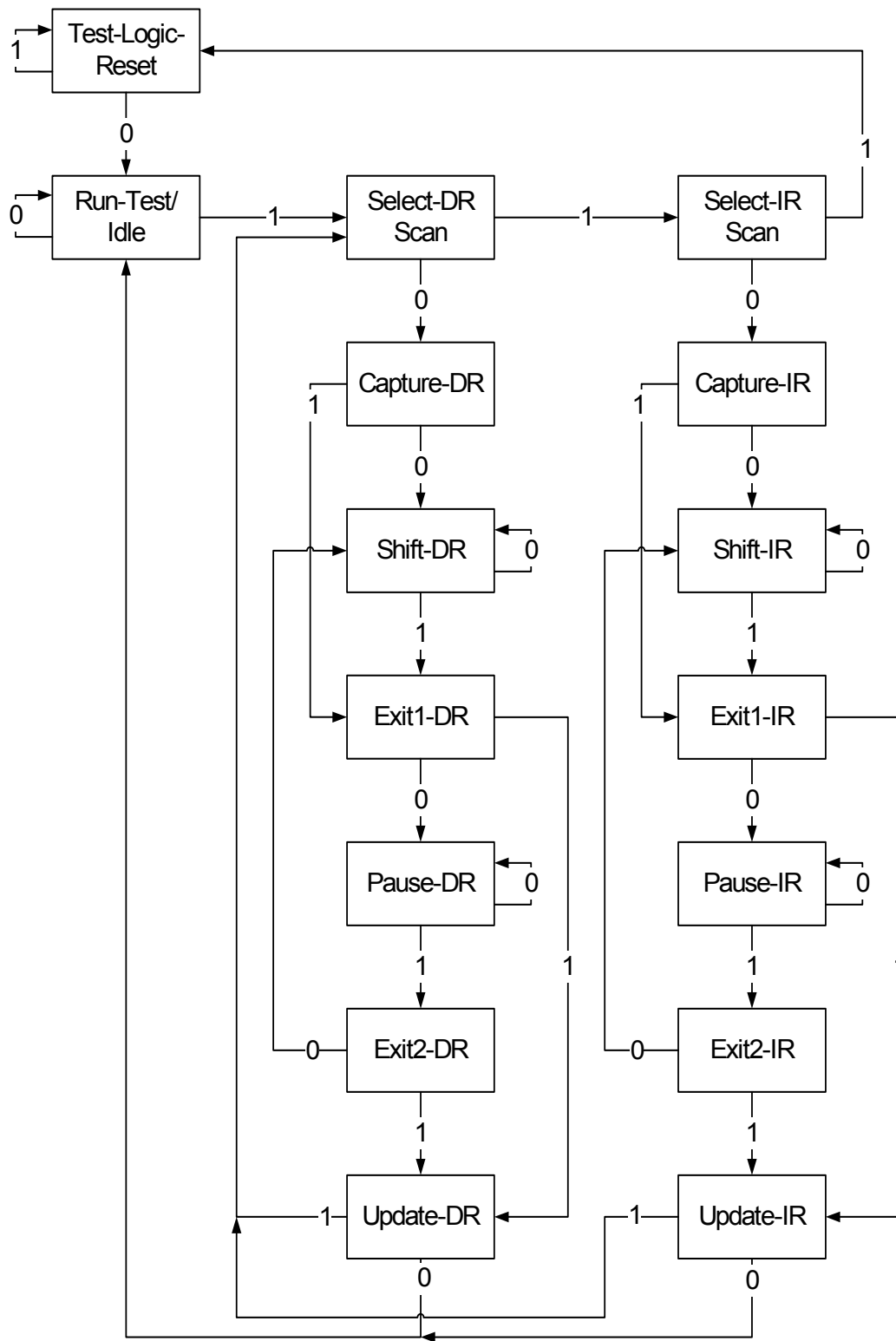

27.4.7 How to Initialize the Module

To enable the TMS, TDI and TDO pins one clock pulse should be applied on TCK.

Independent of the initial state of the TAP Controller, the Test-Logic-Reset state can always be entered by holding TMS high for 5 TCK clock periods. This sequence should always be applied at the start of a JTAG session and after enabling the JTAG pins to bring the TAP Controller into a defined state before applying JTAG commands. Applying a 0 on TMS for 1 TCK period brings the TAP Controller to the Run-Test/Idle state, which is the starting point for JTAG operations.

27.4.8 How to disable the module

To disable the TMS, TDI, and TDO pins the RESET_N pin must be pulled low.

27.4.9 Typical Sequence

Assuming Run-Test/Idle is the present state, a typical scenario for using the JTAG Interface follows.

27.4.9.1 Scanning in JTAG Instruction

At the TMS input, apply the sequence 1, 1, 0, 0 at the rising edges of TCK to enter the Shift Instruction Register (Shift-IR) state. While in this state, shift the 5 bits of the JTAG instructions into the JTAG instruction register from the TDI input at the rising edge of TCK. During shifting, the JTAG outputs status bits on TDO, refer to [Section 27.5](#) for a description of these. The TMS input must be held low during input of the 4 LSBs in order to remain in the Shift-IR state. The JTAG Instruction selects a particular Data Register as path between TDI and TDO and controls the circuitry surrounding the selected Data Register.

Apply the TMS sequence 1, 1, 0 to re-enter the Run-Test/Idle state. The instruction is latched onto the parallel output from the shift register path in the Update-IR state. The Exit-IR, Pause-IR, and Exit2-IR states are only used for navigating the state machine.

Figure 27-6. Scanning in JTAG Instruction

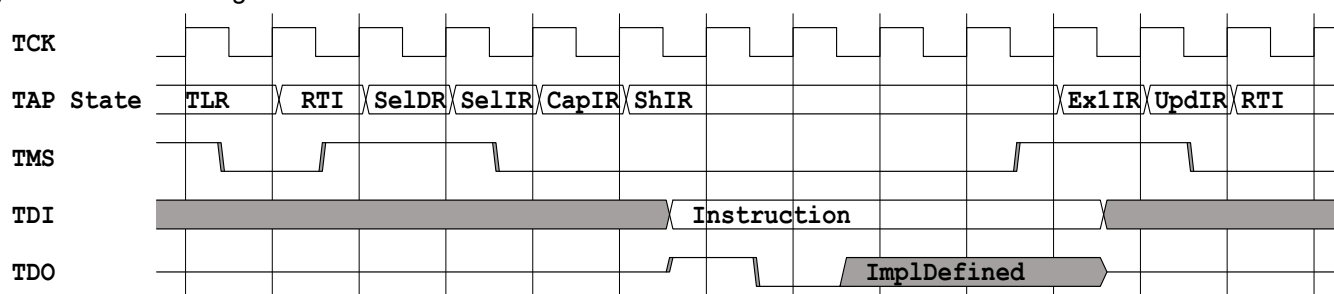

27.4.9.2 Scanning in/out Data

At the TMS input, apply the sequence 1, 0, 0 at the rising edges of TCK to enter the Shift Data Register (Shift-DR) state. While in this state, upload the selected Data Register (selected by the present JTAG instruction in the JTAG Instruction Register) from the TDI input at the rising edge of TCK. In order to remain in the Shift-DR state, the TMS input must be held low. While the Data Register is shifted in from the TDI pin, the parallel inputs to the Data Register captured in the Capture-DR state is shifted out on the TDO pin.

Apply the TMS sequence 1, 1, 0 to re-enter the Run-Test/Idle state. If the selected Data Register has a latched parallel-output, the latching takes place in the Update-DR state. The Exit-DR, Pause-DR, and Exit2-DR states are only used for navigating the state machine.

As shown in the state diagram, the Run-Test/Idle state need not be entered between selecting JTAG instruction and using Data Registers.

27.4.10 Boundary-scan

The boundary-scan chain has the capability of driving and observing the logic levels on the digital I/O pins, as well as the boundary between digital and analog logic for analog circuitry having off-chip connections. At system level, all ICs having JTAG capabilities are connected serially by the TDI/TDO signals to form a long shift register. An external controller sets up the devices to drive values at their output pins, and observe the input values received from other devices. The controller compares the received data with the expected result. In this way, boundary-scan provides a mechanism for testing interconnections and integrity of components on Printed Circuits Boards by using the 4 TAP signals only.

The four IEEE 1149.1 defined mandatory JTAG instructions IDCODE, BYPASS, SAMPLE/PRELOAD, and EXTEST can be used for testing the Printed Circuit Board. Initial scanning of the data register path will show the ID-code of the device, since IDCODE is the default JTAG instruction. It may be desirable to have the 32-bit AVR device in reset during test mode. If not reset, inputs to the device may be determined by the scan operations, and the internal software may be in an undetermined state when exiting the test mode. If needed, the BYPASS instruction can be issued to make the shortest possible scan chain through the device. The device can be set in the reset state either by pulling the external RESETn pin low, or issuing the AVR_RESET instruction with appropriate setting of the Reset Data Register.

The EXTEST instruction is used for sampling external pins and loading output pins with data. The data from the output latch will be driven out on the pins as soon as the EXTEST instruction is loaded into the JTAG IR-register. Therefore, the SAMPLE/PRELOAD should also be used for setting initial values to the scan ring, to avoid damaging the board when issuing the EXTEST instruction for the first time. SAMPLE/PRELOAD can also be used for taking a snapshot of the external pins during normal operation of the part.

When using the JTAG Interface for boundary-scan, the JTAG TCK clock is independent of the internal chip clock. The internal chip clock is not required to run during boundary-scan operations.

NOTE: For pins connected to 5V lines care should be taken to not drive the pins to a logic one using boundary-scan, as this will create a current flowing from the 3,3V driver to the 5V pull-up on the line. Optionally a series resistor can be added between the line and the pin to reduce the current.

Details about the boundary-scan chain can be found in the BSDL file for the device. This can be found on the Atmel website.

27.4.11 Service Access Bus

The AVR32 architecture offers a common interface for access to On-Chip Debug, programming, and test functions. These are mapped on a common bus called the Service Access Bus (SAB), which is linked to the JTAG through a bus master module, which also handles synchronization between the TCK and SAB clocks.



For more information about the SAB and a list of SAB slaves see the Service Access Bus chapter.

27.4.11.1 SAB Address Mode

The MEMORY_SIZED_ACCESS instruction allows a sized read or write to any 36-bit address on the bus. MEMORY_WORD_ACCESS is a shorthand instruction for 32-bit accesses to any 36-bit address, while the NEXUS_ACCESS instruction is a Nexus-compliant shorthand instruction for accessing the 32-bit OCD registers in the 7-bit address space reserved for these. These instructions require two passes through the Shift-DR TAP state: one for the address and control information, and one for data.

27.4.11.2 Block Transfer

To increase the transfer rate, consecutive memory accesses can be accomplished by the MEMORY_BLOCK_ACCESS instruction, which only requires a single pass through Shift-DR for data transfer only. The address is automatically incremented according to the size of the last SAB transfer.

27.4.11.3 Canceling a SAB Access

It is possible to abort an ongoing SAB access by the CANCEL_ACCESS instruction, to avoid hanging the bus due to an extremely slow slave.

27.4.11.4 Busy Reporting

As the time taken to perform an access may vary depending on system activity and current chip frequency, all the SAB access JTAG instructions can return a busy indicator. This indicates whether a delay needs to be inserted, or an operation needs to be repeated in order to be successful. If a new access is requested while the SAB is busy, the request is ignored.

The SAB becomes busy when:

- Entering Update-DR in the address phase of any read operation, e.g., after scanning in a NEXUS_ACCESS address with the read bit set.
- Entering Update-DR in the data phase of any write operation, e.g., after scanning in data for a NEXUS_ACCESS write.
- Entering Update-DR during a MEMORY_BLOCK_ACCESS.
- Entering Update-DR after scanning in a counter value for SYNC.
- Entering Update-IR after scanning in a MEMORY_BLOCK_ACCESS if the previous access was a read and data was scanned after scanning the address.

The SAB becomes ready again when:

- A read or write operation completes.
- A SYNC countdown completed.
- A operation is cancelled by the CANCEL_ACCESS instruction.

What to do if the busy bit is set:

- During Shift-IR: The new instruction is selected, but the previous operation has not yet completed and will continue (unless the new instruction is CANCEL_ACCESS). You may continue shifting the same instruction until the busy bit clears, or start shifting data. If shifting data, you must be prepared that the data shift may also report busy.
- During Shift-DR of an address: The new address is ignored. The SAB stays in address mode, so no data must be shifted. Repeat the address until the busy bit clears.

- During Shift-DR of read data: The read data is invalid. The SAB stays in data mode. Repeat scanning until the busy bit clears.
- During Shift-DR of write data: The write data is ignored. The SAB stays in data mode. Repeat scanning until the busy bit clears.

27.4.11.5 Error Reporting

The Service Access Bus may not be able to complete all accesses as requested. This may be because the address is invalid, the addressed area is read-only or cannot handle byte/halfword accesses, or because the chip is set in a protected mode where only limited accesses are allowed.

The error bit is updated when an access completes, and is cleared when a new access starts.

What to do if the error bit is set:

- During Shift-IR: The new instruction is selected. The last operation performed using the old instruction did not complete successfully.
- During Shift-DR of an address: The previous operation failed. The new address is accepted. If the read bit is set, a read operation is started.
- During Shift-DR of read data: The read operation failed, and the read data is invalid.
- During Shift-DR of write data: The previous write operation failed. The new data is accepted and a write operation started. This should only occur during block writes or stream writes. No error can occur between scanning a write address and the following write data.
- While polling with CANCEL_ACCESS: The previous access was cancelled. It may or may not have actually completed.
- After power-up: The error bit is set after power up, but there has been no previous SAB instruction so this error can be discarded.

27.4.11.6 Protected Reporting

A protected status may be reported during Shift-IR or Shift-DR. This indicates that the security bit in the Flash Controller is set and that the chip is locked for access, according to [Section 27.5.1](#).

The protected state is reported when:

- The Flash Controller is under reset. This can be due to the AVR_RESET command or the RESET_N line.
- The Flash Controller has not read the security bit from the flash yet (This will take a few ms). Happens after the Flash Controller reset has been released.
- The security bit in the Flash Controller is set.

What to do if the protected bit is set:

- Release all active AVR_RESET domains, if any.
- Release the RESET_N line.
- Wait a few ms for the security bit to clear. It can be set temporarily due to a reset.
- Perform a CHIP_ERASE to clear the security bit. **NOTE:** This will erase all the contents of the non-volatile memory.

27.5 JTAG Instruction Summary

The implemented JTAG instructions in the 32-bit AVR are shown in the table below.

Table 27-7. JTAG Instruction Summary

| Instruction OPCODE | Instruction | Description |
|--------------------|---------------------|--|
| 0x01 | IDCODE | Select the 32-bit Device Identification register as data register. |
| 0x02 | SAMPLE_PRELOAD | Take a snapshot of external pin values without affecting system operation. |
| 0x03 | EXTEST | Select boundary-scan chain as data register for testing circuitry external to the device. |
| 0x04 | INTEST | Select boundary-scan chain for internal testing of the device. |
| 0x06 | CLAMP | Bypass device through Bypass register, while driving outputs from boundary-scan register. |
| 0x0C | AVR_RESET | Apply or remove a static reset to the device |
| 0x0F | CHIP_ERASE | Erase the device |
| 0x10 | NEXUS_ACCESS | Select the SAB Address and Data registers as data register for the TAP. The registers are accessed in Nexus mode. |
| 0x11 | MEMORY_WORD_ACCESS | Select the SAB Address and Data registers as data register for the TAP. |
| 0x12 | MEMORY_BLOCK_ACCESS | Select the SAB Data register as data register for the TAP. The address is auto-incremented. |
| 0x13 | CANCEL_ACCESS | Cancel an ongoing Nexus or Memory access. |
| 0x14 | MEMORY_SERVICE | Select the SAB Address and Data registers as data register for the TAP. The registers are accessed in Memory Service mode. |
| 0x15 | MEMORY_SIZED_ACCESS | Select the SAB Address and Data registers as data register for the TAP. |
| 0x17 | SYNC | Synchronization counter |
| 0x1C | HALT | Halt the CPU for safe programming. |
| 0x1F | BYPASS | Bypass this device through the bypass register. |
| Others | N/A | Acts as BYPASS |

27.5.1 Security Restrictions

When the security fuse in the Flash is programmed, the following JTAG instructions are restricted:

- NEXUS_ACCESS
- MEMORY_WORD_ACCESS
- MEMORY_BLOCK_ACCESS
- MEMORY_SIZED_ACCESS

For description of what memory locations remain accessible, please refer to the SAB address map.

Full access to these instructions is re-enabled when the security fuse is erased by the CHIP_ERASE JTAG instruction.

Note that the security bit will read as programmed and block these instructions also if the Flash Controller is statically reset.

Other security mechanisms can also restrict these functions. If such mechanisms are present they are listed in the SAB address map section.

27.5.1.1 Notation

Table 27-9 on page 591 shows bit patterns to be shifted in a format like "**peb01**". Each character corresponds to one bit, and eight bits are grouped together for readability. The least significant-bit is always shifted first, and the most significant bit shifted last. The symbols used are shown in Table 27-8.

Table 27-8. Symbol Description

| Symbol | Description |
|--------|---|
| 0 | Constant low value - always reads as zero. |
| 1 | Constant high value - always reads as one. |
| a | An address bit - always scanned with the least significant bit first |
| b | A busy bit. Reads as one if the SAB was busy, or zero if it was not. See Section 27.4.11.4 for details on how the busy reporting works. |
| d | A data bit - always scanned with the least significant bit first. |
| e | An error bit. Reads as one if an error occurred, or zero if not. See Section 27.4.11.5 for details on how the error reporting works. |
| p | The chip protected bit. Some devices may be set in a protected state where access to chip internals are severely restricted. See the documentation for the specific device for details. On devices without this possibility, this bit always reads as zero. |
| r | A direction bit. Set to one to request a read, set to zero to request a write. |
| s | A size bit. The size encoding is described where used. |
| x | A don't care bit. Any value can be shifted in, and output data should be ignored. |

In many cases, it is not required to shift all bits through the data register. Bit patterns are shown using the full width of the shift register, but the suggested or required bits are emphasized using **bold** text. I.e. given the pattern "**aaaaaar** xxxxxxxx xxxxxxxx xxxxxxxx xx", the shift register is 34 bits, but the test or debug unit may choose to shift only 8 bits "**aaaaaar**".

The following describes how to interpret the fields in the instruction description tables:

Table 27-9. Instruction Description

| Instruction | Description |
|-----------------|---|
| IR input value | Shows the bit pattern to shift into IR in the Shift-IR state in order to select this instruction. The pattern is show both in binary and in hexadecimal form for convenience. Example: 10000 (0x10) |
| IR output value | Shows the bit pattern shifted out of IR in the Shift-IR state when this instruction is active. Example: peb01 |

Table 27-9. Instruction Description (Continued)

| Instruction | Description |
|-----------------|---|
| DR Size | Shows the number of bits in the data register chain when this instruction is active. Example: 34 bits |
| DR input value | Shows which bit pattern to shift into the data register in the Shift-DR state when this instruction is active. Multiple such lines may exist, e.g., to distinguish between reads and writes. Example: aaaaaaar xxxxxxxx xxxxxxxx xxxxxxxx xx |
| DR output value | Shows the bit pattern shifted out of the data register in the Shift-DR state when this instruction is active. Multiple such lines may exist, e.g., to distinguish between reads and writes. Example: xx xxxxxxxx xxxxxxxx xxxxxxxx xxxxxxeb |

27.5.2 Public JTAG Instructions

The JTAG standard defines a number of public JTAG instructions. These instructions are described in the sections below.

27.5.2.1 IDCODE

This instruction selects the 32 bit Device Identification register (DID) as Data Register. The DID register consists of a version number, a device number, and the manufacturer code chosen by JEDEC. This is the default instruction after a JTAG reset. Details about the DID register can be found in the module configuration section at the end of this chapter.

Starting in Run-Test/Idle, the Device Identification register is accessed in the following way:

1. Select the IR Scan path.
2. In Capture-IR: The IR output value is latched into the shift register.
3. In Shift-IR: The instruction register is shifted by the TCK input.
4. Return to Run-Test/Idle.
5. Select the DR Scan path.
6. In Capture-DR: The IDCODE value is latched into the shift register.
7. In Shift-DR: The IDCODE scan chain is shifted by the TCK input.
8. Return to Run-Test/Idle.

Table 27-10. IDCODE Details

| Instructions | Details |
|-----------------|-------------------------------------|
| IR input value | 00001 (0x01) |
| IR output value | p0001 |
| DR Size | 32 |
| DR input value | xxxxxxxx xxxxxxxx xxxxxxxx xxxxxxxx |
| DR output value | Device Identification Register |

27.5.2.2 SAMPLE_PRELOAD

This instruction takes a snap-shot of the input/output pins without affecting the system operation, and pre-loading the scan chain without updating the DR-latch. The boundary-scan chain is selected as Data Register.

Starting in Run-Test/Idle, the Device Identification register is accessed in the following way:

1. Select the IR Scan path.
2. In Capture-IR: The IR output value is latched into the shift register.
3. In Shift-IR: The instruction register is shifted by the TCK input.
4. Return to Run-Test/Idle.
5. Select the DR Scan path.
6. In Capture-DR: The Data on the external pins are sampled into the boundary-scan chain.
7. In Shift-DR: The boundary-scan chain is shifted by the TCK input.
8. Return to Run-Test/Idle.

Table 27-11. SAMPLE_PRELOAD Details

| Instructions | Details |
|-----------------|--|
| IR input value | 00010 (0x02) |
| IR output value | p0001 |
| DR Size | Depending on boundary-scan chain, see BSDL-file. |
| DR input value | Depending on boundary-scan chain, see BSDL-file. |
| DR output value | Depending on boundary-scan chain, see BSDL-file. |

27.5.2.3 EXTEST

This instruction selects the boundary-scan chain as Data Register for testing circuitry external to the 32-bit AVR package. The contents of the latched outputs of the boundary-scan chain is driven out as soon as the JTAG IR-register is loaded with the EXTEST instruction.

Starting in Run-Test/Idle, the EXTEST instruction is accessed the following way:

1. Select the IR Scan path.
2. In Capture-IR: The IR output value is latched into the shift register.
3. In Shift-IR: The instruction register is shifted by the TCK input.
4. In Update-IR: The data from the boundary-scan chain is applied to the output pins.
5. Return to Run-Test/Idle.
6. Select the DR Scan path.
7. In Capture-DR: The data on the external pins is sampled into the boundary-scan chain.
8. In Shift-DR: The boundary-scan chain is shifted by the TCK input.
9. In Update-DR: The data from the scan chain is applied to the output pins.
10. Return to Run-Test/Idle.

Table 27-12. EXTEST Details

| Instructions | Details |
|-----------------|--|
| IR input value | 00011 (0x03) |
| IR output value | p0001 |
| DR Size | Depending on boundary-scan chain, see BSDL-file. |
| DR input value | Depending on boundary-scan chain, see BSDL-file. |
| DR output value | Depending on boundary-scan chain, see BSDL-file. |

27.5.2.4 INTEST

This instruction selects the boundary-scan chain as Data Register for testing internal logic in the device. The logic inputs are determined by the boundary-scan chain, and the logic outputs are captured by the boundary-scan chain. The device output pins are driven from the boundary-scan chain.

Starting in Run-Test/Idle, the INTEST instruction is accessed the following way:

1. Select the IR Scan path.
2. In Capture-IR: The IR output value is latched into the shift register.
3. In Shift-IR: The instruction register is shifted by the TCK input.
4. In Update-IR: The data from the boundary-scan chain is applied to the internal logic inputs.
5. Return to Run-Test/Idle.
6. Select the DR Scan path.
7. In Capture-DR: The data on the internal logic is sampled into the boundary-scan chain.
8. In Shift-DR: The boundary-scan chain is shifted by the TCK input.
9. In Update-DR: The data from the boundary-scan chain is applied to internal logic inputs.
10. Return to Run-Test/Idle.

Table 27-13. INTEST Details

| Instructions | Details |
|-----------------|--|
| IR input value | 00100 (0x04) |
| IR output value | p0001 |
| DR Size | Depending on boundary-scan chain, see BSDL-file. |
| DR input value | Depending on boundary-scan chain, see BSDL-file. |
| DR output value | Depending on boundary-scan chain, see BSDL-file. |

27.5.2.5 CLAMP

This instruction selects the Bypass register as Data Register. The device output pins are driven from the boundary-scan chain.

Starting in Run-Test/Idle, the CLAMP instruction is accessed the following way:

1. Select the IR Scan path.
2. In Capture-IR: The IR output value is latched into the shift register.
3. In Shift-IR: The instruction register is shifted by the TCK input.
4. In Update-IR: The data from the boundary-scan chain is applied to the output pins.
5. Return to Run-Test/Idle.
6. Select the DR Scan path.
7. In Capture-DR: A logic '0' is loaded into the Bypass Register.
8. In Shift-DR: Data is scanned from TDI to TDO through the Bypass register.

9. Return to Run-Test/Idle.

Table 27-14. CLAMP Details

| Instructions | Details |
|-----------------|--------------|
| IR input value | 00110 (0x06) |
| IR output value | p0001 |
| DR Size | 1 |
| DR input value | x |
| DR output value | x |

27.5.2.6 BYPASS

This instruction selects the 1-bit Bypass Register as Data Register.

Starting in Run-Test/Idle, the CLAMP instruction is accessed the following way:

1. Select the IR Scan path.
2. In Capture-IR: The IR output value is latched into the shift register.
3. In Shift-IR: The instruction register is shifted by the TCK input.
4. Return to Run-Test/Idle.
5. Select the DR Scan path.
6. In Capture-DR: A logic '0' is loaded into the Bypass Register.
7. In Shift-DR: Data is scanned from TDI to TDO through the Bypass register.
8. Return to Run-Test/Idle.

Table 27-15. BYPASS Details

| Instructions | Details |
|-----------------|--------------|
| IR input value | 11111 (0x1F) |
| IR output value | p0001 |
| DR Size | 1 |
| DR input value | x |
| DR output value | x |

27.5.3 Private JTAG Instructions

The 32-bit AVR defines a number of private JTAG instructions, not defined by the JTAG standard. Each instruction is briefly described in text, with details following in table form.

27.5.3.1 NEXUS_ACCESS

This instruction allows Nexus-compliant access to the On-Chip Debug registers through the SAB. The 7-bit register index, a read/write control bit, and the 32-bit data is accessed through the JTAG port.

The data register is alternately interpreted by the SAB as an address register and a data register. The SAB starts in address mode after the NEXUS_ACCESS instruction is selected, and toggles between address and data mode each time a data scan completes with the busy bit cleared.

NOTE: The polarity of the direction bit is inverse of the Nexus standard.

Starting in Run-Test/Idle, OCD registers are accessed in the following way:

1. Select the IR Scan path.
2. In Capture-IR: The IR output value is latched into the shift register.
3. In Shift-IR: The instruction register is shifted by the TCK input.
4. Return to Run-Test/Idle.
5. Select the DR Scan path.
6. In Shift-DR: Scan in the direction bit (1=read, 0=write) and the 7-bit address for the OCD register.
7. Go to Update-DR and re-enter Select-DR Scan.
8. In Shift-DR: For a read operation, scan out the contents of the addressed register. For a write operation, scan in the new contents of the register.
9. Return to Run-Test/Idle.

For any operation, the full 7 bits of the address must be provided. For write operations, 32 data bits must be provided, or the result will be undefined. For read operations, shifting may be terminated once the required number of bits have been acquired.

Table 27-16. NEXUS_ACCESS Details

| Instructions | Details |
|------------------------------------|---|
| IR input value | 10000 (0x10) |
| IR output value | peb01 |
| DR Size | 34 bits |
| DR input value (Address phase) | aaaaaaar xxxxxxxx xxxxxxxx xxxxxxxx xx |
| DR input value (Data read phase) | xxxxxxxx xxxxxxxx xxxxxxxx xxxxxxxx xx |
| DR input value (Data write phase) | dddddddd dddddddd dddddddd dddddddd xx |
| DR output value (Address phase) | xx xxxxxxxx xxxxxxxx xxxxxxxx xxxxxx eb |
| DR output value (Data read phase) | eb dddddddd dddddddd dddddddd dddddddd |
| DR output value (Data write phase) | xx xxxxxxxx xxxxxxxx xxxxxxxx xxxxxx eb |

27.5.3.2 MEMORY_SERVICE

This instruction allows access to registers in an optional Memory Service Unit. The 7-bit register index, a read/write control bit, and the 32-bit data is accessed through the JTAG port.

The data register is alternately interpreted by the SAB as an address register and a data register. The SAB starts in address mode after the MEMORY_SERVICE instruction is selected, and toggles between address and data mode each time a data scan completes with the busy bit cleared.

Starting in Run-Test/Idle, Memory Service registers are accessed in the following way:

1. Select the IR Scan path.
2. In Capture-IR: The IR output value is latched into the shift register.
3. In Shift-IR: The instruction register is shifted by the TCK input.
4. Return to Run-Test/Idle.
5. Select the DR Scan path.
6. In Shift-DR: Scan in the direction bit (1=read, 0=write) and the 7-bit address for the Memory Service register.



7. Go to Update-DR and re-enter Select-DR Scan.
8. In Shift-DR: For a read operation, scan out the contents of the addressed register. For a write operation, scan in the new contents of the register.
9. Return to Run-Test/Idle.

For any operation, the full 7 bits of the address must be provided. For write operations, 32 data bits must be provided, or the result will be undefined. For read operations, shifting may be terminated once the required number of bits have been acquired.

Table 27-17. MEMORY_SERVICE Details

| Instructions | Details |
|------------------------------------|---|
| IR input value | 10100 (0x14) |
| IR output value | peb01 |
| DR Size | 34 bits |
| DR input value (Address phase) | aaaaaaar xxxxxxxx xxxxxxxx xxxxxxxx xx |
| DR input value (Data read phase) | xxxxxxxx xxxxxxxx xxxxxxxx xxxxxxxx xx |
| DR input value (Data write phase) | dddddddd dddddddd dddddddd dddddddd xx |
| DR output value (Address phase) | xx xxxxxxxx xxxxxxxx xxxxxxxx xxxxxeb |
| DR output value (Data read phase) | eb dddddddd dddddddd dddddddd dddddddd |
| DR output value (Data write phase) | xx xxxxxxxx xxxxxxxx xxxxxxxx xxxxxeb |

27.5.3.3 MEMORY_SIZED_ACCESS

This instruction allows access to the entire Service Access Bus data area. Data is accessed through a 36-bit byte index, a 2-bit size, a direction bit, and 8, 16, or 32 bits of data. Not all units mapped on the SAB bus may support all sizes of accesses, e.g., some may only support word accesses.

The data register is alternately interpreted by the SAB as an address register and a data register. The SAB starts in address mode after the MEMORY_SIZED_ACCESS instruction is selected, and toggles between address and data mode each time a data scan completes with the busy bit cleared.

The size field is encoded as in [Table 27-18](#).

Table 27-18. Size Field Semantics

| Size field value | Access size | Data alignment |
|------------------|--------------------|---|
| 00 | Byte (8 bits) | Address modulo 4 : data alignment 0: ddddddd xxxxxxxx xxxxxxxx xxxxxxxx 1: xxxxxxxx ddddddd xxxxxxxx xxxxxxxx 2: xxxxxxxx xxxxxxxx ddddddd xxxxxxxx 3: xxxxxxxx xxxxxxxx xxxxxxxx ddddddd |
| 01 | Halfword (16 bits) | Address modulo 4 : data alignment 0: ddddddd ddddddd xxxxxxxx xxxxxxxx 1: Not allowed 2: xxxxxxxx xxxxxxxx ddddddd ddddddd 3: Not allowed |
| 10 | Word (32 bits) | Address modulo 4 : data alignment 0: ddddddd ddddddd ddddddd ddddddd 1: Not allowed 2: Not allowed 3: Not allowed |
| 11 | Reserved | N/A |

Starting in Run-Test/Idle, SAB data is accessed in the following way:

1. Select the IR Scan path.
2. In Capture-IR: The IR output value is latched into the shift register.
3. In Shift-IR: The instruction register is shifted by the TCK input.
4. Return to Run-Test/Idle.
5. Select the DR Scan path.
6. In Shift-DR: Scan in the direction bit (1=read, 0=write), 2-bit access size, and the 36-bit address of the data to access.
7. Go to Update-DR and re-enter Select-DR Scan.
8. In Shift-DR: For a read operation, scan out the contents of the addressed area. For a write operation, scan in the new contents of the area.
9. Return to Run-Test/Idle.

For any operation, the full 36 bits of the address must be provided. For write operations, 32 data bits must be provided, or the result will be undefined. For read operations, shifting may be terminated once the required number of bits have been acquired.

Table 27-19. MEMORY_SIZED_ACCESS Details

| Instructions | Details |
|-----------------------------------|--|
| IR input value | 10101 (0x15) |
| IR output value | peb01 |
| DR Size | 39 bits |
| DR input value (Address phase) | aaaaaaaa aaaaaaaaa aaaaaaaaa aaaaaaaaa aaaassr |
| DR input value (Data read phase) | xxxxxxxx xxxxxxxx xxxxxxxx xxxxxxxx xxxxxxx |
| DR input value (Data write phase) | ddddddd ddddddd ddddddd ddddddd xxxxxxx |

Table 27-19. MEMORY_SIZED_ACCESS Details (Continued)

| Instructions | Details |
|------------------------------------|---|
| DR output value (Address phase) | xxxxxxx xxxxxxxx xxxxxxxx xxxxxxxx xxxxxxeb |
| DR output value (Data read phase) | xxxxxeb dddddddd dddddddd dddddddd dddddddd |
| DR output value (Data write phase) | xxxxxxx xxxxxxxx xxxxxxxx xxxxxxxx xxxxxxeb |

27.5.3.4 MEMORY_WORD_ACCESS

This instruction allows access to the entire Service Access Bus data area. Data is accessed through the 34 MSB of the SAB address, a direction bit, and 32 bits of data. This instruction is identical to MEMORY_SIZED_ACCESS except that it always does word sized accesses. The size field is implied, and the two lowest address bits are removed and not scanned in.

Note: This instruction was previously known as MEMORY_ACCESS, and is provided for backwards compatibility.

The data register is alternately interpreted by the SAB as an address register and a data register. The SAB starts in address mode after the MEMORY_WORD_ACCESS instruction is selected, and toggles between address and data mode each time a data scan completes with the busy bit cleared.

Starting in Run-Test/Idle, SAB data is accessed in the following way:

1. Select the IR Scan path.
2. In Capture-IR: The IR output value is latched into the shift register.
3. In Shift-IR: The instruction register is shifted by the TCK input.
4. Return to Run-Test/Idle.
5. Select the DR Scan path.
6. In Shift-DR: Scan in the direction bit (1=read, 0=write) and the 34-bit address of the data to access.
7. Go to Update-DR and re-enter Select-DR Scan.
8. In Shift-DR: For a read operation, scan out the contents of the addressed area. For a write operation, scan in the new contents of the area.
9. Return to Run-Test/Idle.

For any operation, the full 34 bits of the address must be provided. For write operations, 32 data bits must be provided, or the result will be undefined. For read operations, shifting may be terminated once the required number of bits have been acquired.

Table 27-20. MEMORY_WORD_ACCESS Details

| Instructions | Details |
|-----------------------------------|--|
| IR input value | 10001 (0x11) |
| IR output value | peb01 |
| DR Size | 35 bits |
| DR input value (Address phase) | aaaaaaaa aaaaaaaaa aaaaaaaaa aaaaaaaaa aar |
| DR input value (Data read phase) | xxxxxxxx xxxxxxxx xxxxxxxx xxxxxxxx xxx |
| DR input value (Data write phase) | dddddddd dddddddd dddddddd dddddddd xxx |

Table 27-20. MEMORY_WORD_ACCESS Details (Continued)

| Instructions | Details |
|------------------------------------|---|
| DR output value (Address phase) | xxxxxxxx xxxxxxxx xxxxxxxx xxxxxxxx xeb |
| DR output value (Data read phase) | xeb dddddddd dddddddd dddddddd dddddddd |
| DR output value (Data write phase) | xxx xxxxxxxx xxxxxxxx xxxxxxxx xxxxxxeb |

27.5.3.5 MEMORY_BLOCK_ACCESS

This instruction allows access to the entire SAB data area. Up to 32 bits of data is accessed at a time, while the address is sequentially incremented from the previously used address.

In this mode, the SAB address, size, and access direction is not provided with each access. Instead, the previous address is auto-incremented depending on the specified size and the previous operation repeated. The address must be set up in advance with MEMORY_SIZE_ACCESS or MEMORY_WORD_ACCESS. It is allowed, but not required, to shift data after shifting the address.

This instruction is primarily intended to speed up large quantities of sequential word accesses. It is possible to use it also for byte and halfword accesses, but the overhead in this is case much larger as 32 bits must still be shifted for each access.

The following sequence should be used:

1. Use the MEMORY_SIZE_ACCESS or MEMORY_WORD_ACCESS to read or write the first location.
2. Return to Run-Test/Idle.
3. Select the IR Scan path.
4. In Capture-IR: The IR output value is latched into the shift register.
5. In Shift-IR: The instruction register is shifted by the TCK input.
6. Return to Run-Test/Idle.
7. Select the DR Scan path. The address will now have incremented by 1, 2, or 4 (corresponding to the next byte, halfword, or word location).
8. In Shift-DR: For a read operation, scan out the contents of the next addressed location. For a write operation, scan in the new contents of the next addressed location.
9. Go to Update-DR.
10. If the block access is not complete, return to Select-DR Scan and repeat the access.
11. If the block access is complete, return to Run-Test/Idle.

For write operations, 32 data bits must be provided, or the result will be undefined. For read operations, shifting may be terminated once the required number of bits have been acquired.

Table 27-21. MEMORY_BLOCK_ACCESS Details

| Instructions | Details |
|----------------------------------|--|
| IR input value | 10010 (0x12) |
| IR output value | peb01 |
| DR Size | 34 bits |
| DR input value (Data read phase) | xxxxxxxx xxxxxxxx xxxxxxxx xxxxxxxx xx |



Table 27-21. MEMORY_BLOCK_ACCESS Details (Continued)

| Instructions | Details |
|------------------------------------|--|
| DR input value (Data write phase) | dddddddd dddddddd dddddddd dddddddd xx |
| DR output value (Data read phase) | eb dddddddd dddddddd dddddddd dddddddd |
| DR output value (Data write phase) | xx xxxxxxxx xxxxxxxx xxxxxxxx xxxxxxeb |

The overhead using block word access is 4 cycles per 32 bits of data, resulting in an 88% transfer efficiency, or 2.1 MBytes per second with a 20 MHz TCK frequency.

27.5.3.6 CANCEL_ACCESS

If a very slow memory location is accessed during a SAB memory access, it could take a very long time until the busy bit is cleared, and the SAB becomes ready for the next operation. The CANCEL_ACCESS instruction provides a possibility to abort an ongoing transfer and report a timeout to the JTAG master.

When the CANCEL_ACCESS instruction is selected, the current access will be terminated as soon as possible. There are no guarantees about how long this will take, as the hardware may not always be able to cancel the access immediately. The SAB is ready to respond to a new command when the busy bit clears.

Starting in Run-Test/Idle, CANCEL_ACCESS is accessed in the following way:

1. Select the IR Scan path.
2. In Capture-IR: The IR output value is latched into the shift register.
3. In Shift-IR: The instruction register is shifted by the TCK input.
4. Return to Run-Test/Idle.

Table 27-22. CANCEL_ACCESS Details

| Instructions | Details |
|-----------------|--------------|
| IR input value | 10011 (0x13) |
| IR output value | peb01 |
| DR Size | 1 |
| DR input value | x |
| DR output value | 0 |

27.5.3.7 SYNC

This instruction allows external debuggers and testers to measure the ratio between the external JTAG clock and the internal system clock. The SYNC data register is a 16-bit counter that counts down to zero using the internal system clock. The busy bit stays high until the counter reaches zero.

Starting in Run-Test/Idle, SYNC instruction is used in the following way:

1. Select the IR Scan path.
2. In Capture-IR: The IR output value is latched into the shift register.
3. In Shift-IR: The instruction register is shifted by the TCK input.
4. Return to Run-Test/Idle.
5. Select the DR Scan path.

6. Scan in an 16-bit counter value.
7. Go to Update-DR and re-enter Select-DR Scan.
8. In Shift-DR: Scan out the busy bit, and until the busy bit clears goto 7.
9. Calculate an approximation to the internal clock speed using the elapsed time and the counter value.
10. Return to Run-Test/Idle.

The full 16-bit counter value must be provided when starting the synch operation, or the result will be undefined. When reading status, shifting may be terminated once the required number of bits have been acquired.

Table 27-23. SYNC_ACCESS Details

| Instructions | Details |
|-----------------|---------------------|
| IR input value | 10111 (0x17) |
| IR output value | peb01 |
| DR Size | 16 bits |
| DR input value | dddddddd dddddddd |
| DR output value | xxxxxxxx xxxxxxeb |

27.5.3.8 AVR_RESET

This instruction allows a debugger or tester to directly control separate reset domains inside the chip. The shift register contains one bit for each controllable reset domain. Setting a bit to one resets that domain and holds it in reset. Setting a bit to zero releases the reset for that domain.

The AVR_RESET instruction can be used in the following way:

1. Select the IR Scan path.
2. In Capture-IR: The IR output value is latched into the shift register.
3. In Shift-IR: The instruction register is shifted by the TCK input.
4. Return to Run-Test/Idle.
5. Select the DR Scan path.
6. In Shift-DR: Scan in the value corresponding to the reset domains the JTAG master wants to reset into the data register.
7. Return to Run-Test/Idle.
8. Stay in run test idle for at least 10 TCK clock cycles to let the reset propagate to the system.

See the device specific documentation for the number of reset domains, and what these domains are.

For any operation, all bits must be provided or the result will be undefined.

Table 27-24. AVR_RESET Details

| Instructions | Details |
|-----------------|---------------------|
| IR input value | 01100 (0x0C) |
| IR output value | p0001 |

Table 27-24. AVR_RESET Details (Continued)

| Instructions | Details |
|-----------------|------------------|
| DR Size | Device specific. |
| DR input value | Device specific. |
| DR output value | Device specific. |

27.5.3.9 CHIP_ERASE

This instruction allows a programmer to completely erase all nonvolatile memories in a chip. This will also clear any security bits that are set, so the device can be accessed normally. In devices without non-volatile memories this instruction does nothing, and appears to complete immediately.

The erasing of non-volatile memories starts as soon as the CHIP_ERASE instruction is selected. The CHIP_ERASE instruction selects a 1 bit bypass data register.

A chip erase operation should be performed as:

1. Reset the system and stop the CPU from executing.
2. Select the IR Scan path.
3. In Capture-IR: The IR output value is latched into the shift register.
4. In Shift-IR: The instruction register is shifted by the TCK input.
5. Check the busy bit that was scanned out during Shift-IR. If the busy bit was set goto 2.
6. Return to Run-Test/Idle.

Table 27-25. CHIP_ERASE Details

| Instructions | Details |
|-----------------|--|
| IR input value | 01111 (0x0F) |
| IR output value | p0b01 Where b is the <i>busy</i> bit. |
| DR Size | 1 bit |
| DR input value | x |
| DR output value | 0 |

27.5.3.10 HALT

This instruction allows a programmer to easily stop the CPU to ensure that it does not execute invalid code during programming.

This instruction selects a 1-bit halt register. Setting this bit to one resets the device and halts the CPU. Setting this bit to zero resets the device and releases the CPU to run normally. The value shifted out from the data register is one if the CPU is halted.

The HALT instruction can be used in the following way:

1. Select the IR Scan path.
2. In Capture-IR: The IR output value is latched into the shift register.
3. In Shift-IR: The instruction register is shifted by the TCK input.
4. Return to Run-Test/Idle.
5. Select the DR Scan path.

- 6. In Shift-DR: Scan in the value 1 to halt the CPU, 0 to start CPU execution.
- 7. Return to Run-Test/Idle.

Table 27-26. HALT Details

| Instructions | Details |
|---------------------|---------------------|
| IR input value | 11100 (0x1C) |
| IR output value | p0001 |
| DR Size | 1 bit |
| DR input value | d |
| DR output value | d |

27.6 JTAG Data Registers

The following device specific registers can be selected as JTAG scan chain depending on the instruction loaded in the JTAG Instruction Register. Additional registers exist, but are implicitly described in the functional description of the relevant instructions.

27.6.1 Device Identification Register

The Device Identification Register contains a unique identifier for each product. The register is selected by the IDCODE instruction, which is the default instruction after a JTAG reset.

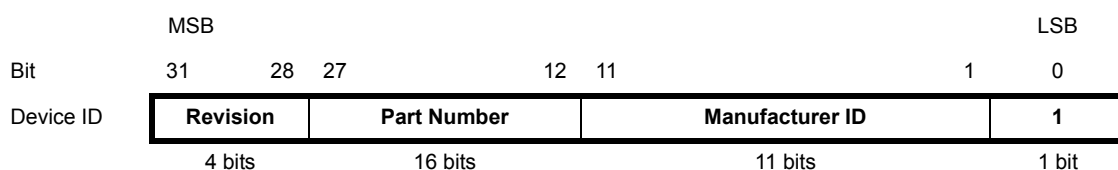

Revision This is a 4 bit number identifying the revision of the component.
Rev A = 0x0, B = 0x1, etc.

Part Number The part number is a 16 bit code identifying the component.

Manufacturer ID The Manufacturer ID is a 11 bit code identifying the manufacturer.
The JTAG manufacturer ID for ATMEL is 0x01F.

27.6.1.1 Device specific ID codes

The different device configurations have different JTAG ID codes, as shown in [Table 27-27](#). Note that if the flash controller is statically reset, the ID code will be undefined.

Table 27-27. Device and JTAG ID

| Device name | JTAG ID code (r is the revision number) |
|--------------|---|
| AT32UC3B0512 | 0xr205003F |
| AT32UC3B1512 | 0xr205203F |
| AT32UC3B0256 | 0xr1EE403F |
| AT32UC3B1256 | 0xr1EE503F |
| AT32UC3B0128 | 0xr1EE603F |
| AT32UC3B1128 | 0xr1EE903F |
| AT32UC3B064 | 0xr1EEA03F |
| AT32UC3B164 | 0xr1EEB03F |

27.6.2 Reset register

The reset register is selected by the AVR_RESET instruction and contains one bit for each reset domain in the device. Setting each bit to one will keep that domain reset until the bit is cleared.

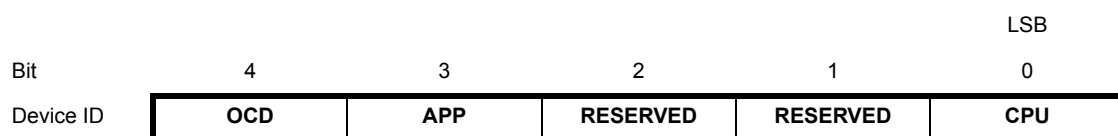

| | |
|----------------|-----------------------------------|
| CPU | CPU |
| APP | HSB and PB buses |
| OCD | On-Chip Debug logic and registers |
| RSERVED | No effect |

Note: This register is primarily intended for compatibility with other 32-bit AVR devices. Certain operations may not function correctly when parts of the system are reset. It is generally recommended to only write 0x11111 or 0x00000 to these bits to ensure no unintended side effects occur.

27.6.3 Boundary-Scan Chain

The Boundary-Scan Chain has the capability of driving and observing the logic levels on the digital I/O pins, as well as driving and observing the logic levels between the digital I/O pins and the internal logic. Typically, output value, output enable, and input data are all available in the boundary scan chain.

The boundary scan chain is described in the BDSL (Boundary Scan Description Language) file available at the Atmel web site.

27.7 SAB address map

The Service Access Bus (SAB) gives the user access to the internal address space and other features through a 36 bits address space. The 4 MSBs identify the slave number, while the 32 LSBs are decoded within the slave's address space. The SAB slaves are shown in [Table 27-28](#).

Table 27-28. SAB Slaves, addresses and descriptions.

| Slave | Address [35:32] | Description |
|---------------------|-----------------|---|
| Unallocated | 0x0 | Intentionally unallocated |
| OCD | 0x1 | OCD registers |
| HSB | 0x4 | HSB memory space, as seen by the CPU |
| HSB | 0x5 | Alternative mapping for HSB space, for compatibility with other 32-bit AVR devices. |
| Memory Service Unit | 0x6 | Memory Service Unit registers |
| Reserved | Other | Unused |

28. Electrical Characteristics

28.1 Absolute Maximum Ratings*

| | |
|---|-----------------|
| Operating Temperature..... | -40°C to +85°C |
| Storage Temperature | -60°C to +150°C |
| Voltage on GPIO Pins with respect to Ground for TCK, RESET_N, PA03, PA04, PA05, PA06, PA07, PA08, PA11, PA12, PA18, PA19, PA28, PA29, PA30, PA31 | -0.3 to 3.6V |
| Voltage on GPIO Pins with respect to Ground except for TCK, RESET_N, PA03, PA04, PA05, PA06, PA07, PA08, PA11, PA12, PA18, PA19, PA28, PA29, PA30, PA31..... | -0.3 to 5.5V |
| Maximum Operating Voltage (VDDCORE, VDDPLL) | 1.95V |
| Maximum Operating Voltage (VDDIO,VDDIN,VDDANA) . | 3.6V |
| Total DC Output Current on all I/O Pin | |
| for 48-pin package | 200 mA |
| for 64-pin package | 265 mA |

*NOTICE: Stresses beyond those listed under “Absolute Maximum Ratings” may cause permanent damage to the device. This is a stress rating only and functional operation of the device at these or other conditions beyond those indicated in the operational sections of this specification is not implied. Exposure to absolute maximum rating conditions for extended periods may affect device reliability.

28.2 DC Characteristics

The following characteristics are applicable to the operating temperature range: $T_A = -40^{\circ}\text{C}$ to 85°C , unless otherwise specified and are certified for a junction temperature up to $T_J = 100^{\circ}\text{C}$.

Table 28-1. DC Characteristics

| Symbol | Parameter | Conditions | Min. | Typ. | Max. | Unit | |
|----------------------|---------------------------|--|--|------|------|---------------|---|
| V_{VDDCORE} | DC Supply Core | | 1.65 | | 1.95 | V | |
| V_{VDDPLL} | DC Supply PLL | | 1.65 | | 1.95 | V | |
| V_{VDDIO} | DC Supply Peripheral I/Os | | 3.0 | | 3.6 | V | |
| V_{IL} | Input Low-level Voltage | | -0.3 | | +0.8 | V | |
| V_{IH} | Input High-level Voltage | AT32UC3B064 AT32UC3B0128 AT32UC3B0256 AT32UC3B164 AT32UC3B1128 AT32UC3B1256 | All I/O pins except TCK, RESET_N, PA03, PA04, PA05, PA06, PA07, PA08, PA11, PA12, PA18, PA19, PA28, PA29, PA30, PA31 | 2.0 | | 5.5 | V |
| | | | TCK, RESET_N, PA03, PA04, PA05, PA06, PA07, PA08, PA11, PA12, PA18, PA19, PA28, PA29, PA30, PA31 | 2.0 | | 3.6 | V |
| | | AT32UC3B0512 AT32UC3B1512 | All I/O pins except TCK, RESET_N, PA03, PA04, PA05, PA06, PA07, PA08, PA11, PA12, PA18, PA19, PA28, PA29, PA30, PA31 | 2.0 | | 5.5 | V |
| | | | TCK, RESET_N | 2.5 | | 3.6 | V |
| | | | PA03, PA04, PA05, PA06, PA07, PA08, PA11, PA12, PA18, PA19, PA28, PA29, PA30, PA31 | 2.0 | | 3.6 | V |
| | | | | | | | |
| V_{OL} | Output Low-level Voltage | $I_{\text{OL}} = -4\text{mA}$ for all I/O except PA20, PA21, PA22, PA23 | | | 0.4 | V | |
| | | $I_{\text{OL}} = -8\text{mA}$ for PA20, PA21, PA22, PA23 | | | 0.4 | V | |
| V_{OH} | Output High-level Voltage | $I_{\text{OL}} = -4\text{mA}$ for all I/O except PA20, PA21, PA22, PA23 | V_{VDDIO} -0.4 | | | V | |
| | | $I_{\text{OL}} = -8\text{mA}$ for PA20, PA21, PA22, PA23 | V_{VDDIO} -0.4 | | | V | |
| I_{OL} | Output Low-level Current | All I/O pins except PA20, PA21, PA22, PA23 | | | -4 | mA | |
| | | PA20, PA21, PA22, PA23 | | | -8 | mA | |
| I_{OH} | Output High-level Current | All I/O pins except for PA20, PA21, PA22, PA23 | | | 4 | mA | |
| | | PA20, PA21, PA22, PA23 | | | 8 | mA | |
| I_{LEAK} | Input Leakage Current | Pullup resistors disabled | | | 1 | μA | |

Table 28-1. DC Characteristics

| Symbol | Parameter | Conditions | Min. | Typ. | Max. | Unit | |
|---|--|---|--|--|--|--------------------------|----|
| C _{IN} | Input Capacitance | QFP64 | | | 7 | pF | |
| | | QFP48 | | | 7 | pF | |
| | | QFN64 | | | 7 | pF | |
| | | QFN48 | | | 7 | pF | |
| R _{PULLUP} | Pull-up Resistance | AT32UC3B064 AT32UC3B0128 AT32UC3B0256 | All I/O pins except RESET_N, TCK, TDI, TMS pins | 13 | 19 | 25 | KΩ |
| | | AT32UC3B164 AT32UC3B1128 AT32UC3B1256 | RESET_N pin, TCK, TDI, TMS pins | 5 | 12 | 25 | KΩ |
| | | AT32UC3B0512 AT32UC3B1512 | All I/O pins except PA20, PA21, PA22, PA23, RESET_N, TCK, TDI, TMS pins | 10 | 15 | 20 | KΩ |
| | | | PA20, PA21, PA22, PA23 | 5 | 7.5 | 12 | KΩ |
| | | | RESET_N pin, TCK, TDI, TMS pins | 5 | 10 | 25 | KΩ |
| | | I _{sc} | Static Current | AT32UC3B064 AT32UC3B0128 AT32UC3B0256 AT32UC3B164 AT32UC3B1128 AT32UC3B1256 | On V _{VDDCORE} = 1.8V, device in static mode | T _A = 25°C | 6 |
| All inputs driven including JTAG; RESET_N=1 | T _A = 85°C | | | | 42.5 | | μA |
| AT32UC3B0512 AT32UC3B1512 | On V _{VDDCORE} = 1.8V, device in static mode | | | T _A = 25°C | 7.5 | | μA |
| | All inputs driven including JTAG; RESET_N=1 | | | T _A = 85°C | 39 | | μA |

28.3 Regulator Characteristics

Table 28-2. Electrical Characteristics

| Symbol | Parameter | Conditions | Min. | Typ. | Max. | Unit |
|---------------------|--------------------------------------|---|------|------|------|------|
| V _{VDDIN} | Supply voltage (input) | | 3 | 3.3 | 3.6 | V |
| V _{VDDOUT} | Supply voltage (output) | | 1.70 | 1.8 | 1.85 | V |
| I _{OUT} | Maximum DC output current | V _{VDDIN} = 3.3V | | | 100 | mA |
| I _{SCR} | Static Current of internal regulator | Low Power mode (stop, deep stop or static) at T _A = 25°C | | 10 | | μA |

Table 28-3. Decoupling Requirements

| Symbol | Parameter | Conditions | Typ. | Technology | Unit |
|-------------------|------------------------------|------------|------|------------|------|
| C _{IN1} | Input Regulator Capacitor 1 | | 1 | NPO | nF |
| C _{IN2} | Input Regulator Capacitor 2 | | 4.7 | X7R | μF |
| C _{OUT1} | Output Regulator Capacitor 1 | | 470 | NPO | pF |
| C _{OUT2} | Output Regulator Capacitor 2 | | 2.2 | X7R | μF |

28.4 Analog Characteristics

28.4.1 ADC Reference

Table 28-4. Electrical Characteristics

| Symbol | Parameter | Conditions | Min. | Typ. | Max. | Unit |
|---------------------|----------------------------------|------------|------|------|------|------|
| V _{ADVREF} | Analog voltage reference (input) | | 2.6 | | 3.6 | V |

Table 28-5. Decoupling Requirements

| Symbol | Parameter | Conditions | Typ. | Technology | Unit |
|--------------------|-------------------------------|------------|------|------------|------|
| C _{VREF1} | Voltage reference Capacitor 1 | | 10 | NPO | nF |
| C _{VREF2} | Voltage reference Capacitor 2 | | 1 | NPO | uF |

28.4.2 BOD

Table 28-6. BOD Level Values

| Symbol | Parameter Value | Conditions | Min. | Typ. | Max. | Unit |
|----------|-----------------|------------|------|------|------|------|
| BODLEVEL | 00 0000b | | | 1.44 | | V |
| | 01 0111b | | | 1.52 | | V |
| | 01 1111b | | | 1.61 | | V |
| | 10 0111b | | | 1.71 | | V |

Table 28-6 describes the values of the BODLEVEL field in the flash FGPFRR register.

Table 28-7. BOD Timing

| Symbol | Parameter | Conditions | Min. | Typ. | Max. | Unit |
|-----------|--|-----------------------------------|------|------|------|------|
| T_{BOD} | Minimum time with VDDCORE < VBOD to detect power failure | Falling VDDCORE from 1.8V to 1.1V | | 300 | 800 | ns |

28.4.3 Reset Sequence

Table 28-8. Electrical Characteristics

| Symbol | Parameter | Conditions | Min. | Typ. | Max. | Unit |
|---------------|--|---|------|------|------|---------|
| V_{DDRR} | VDDCORE rise rate to ensure power-on-reset | | 2.5 | | | V/ms |
| V_{DDFR} | VDDCORE fall rate to ensure power-on-reset | | 0.01 | | 400 | V/ms |
| V_{POR+} | Rising threshold voltage: voltage up to which device is kept under reset by POR on rising VDDCORE | Rising VDDCORE: $V_{RESTART} \rightarrow V_{POR+}$ | 1.4 | 1.55 | 1.65 | V |
| V_{POR-} | Falling threshold voltage: voltage when POR resets device on falling VDDCORE | Falling VDDCORE: $1.8V \rightarrow V_{POR-}$ | 1.2 | 1.3 | 1.4 | V |
| $V_{RESTART}$ | On falling VDDCORE, voltage must go down to this value before supply can rise again to ensure reset signal is released at V_{POR+} | Falling VDDCORE: $1.8V \rightarrow V_{RESTART}$ | -0.1 | | 0.5 | V |
| T_{POR} | Minimum time with VDDCORE < V_{POR-} | Falling VDDCORE: $1.8V \rightarrow 1.1V$ | | 15 | | μs |
| T_{RST} | Time for reset signal to be propagated to system | | | 200 | 400 | μs |
| T_{SSU1} | Time for Cold System Startup: Time for CPU to fetch its first instruction (RCosc not calibrated) | | 480 | | 960 | μs |
| T_{SSU2} | Time for Hot System Startup: Time for CPU to fetch its first instruction (RCosc calibrated) | | | 420 | | μs |

Figure 28-1. MCU Cold Start-Up RESET_N tied to VDDIN

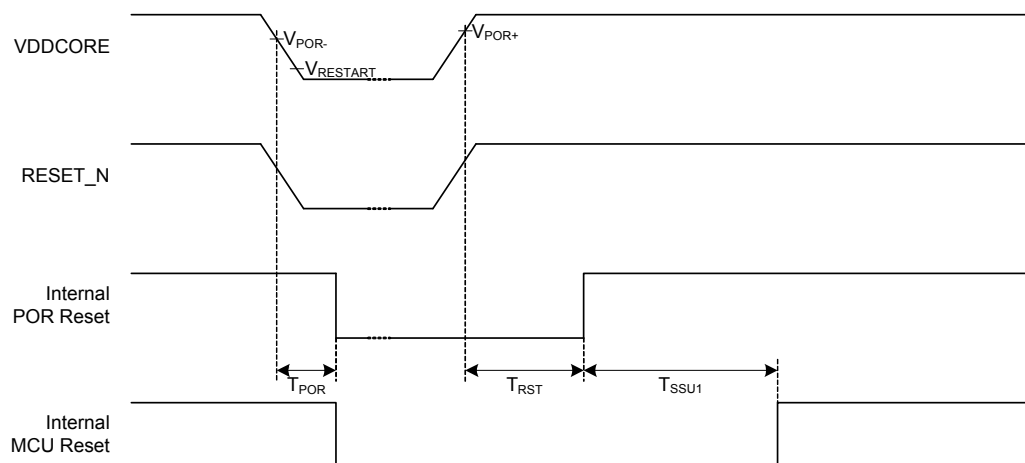

Figure 28-2. MCU Cold Start-Up RESET_N Externally Driven

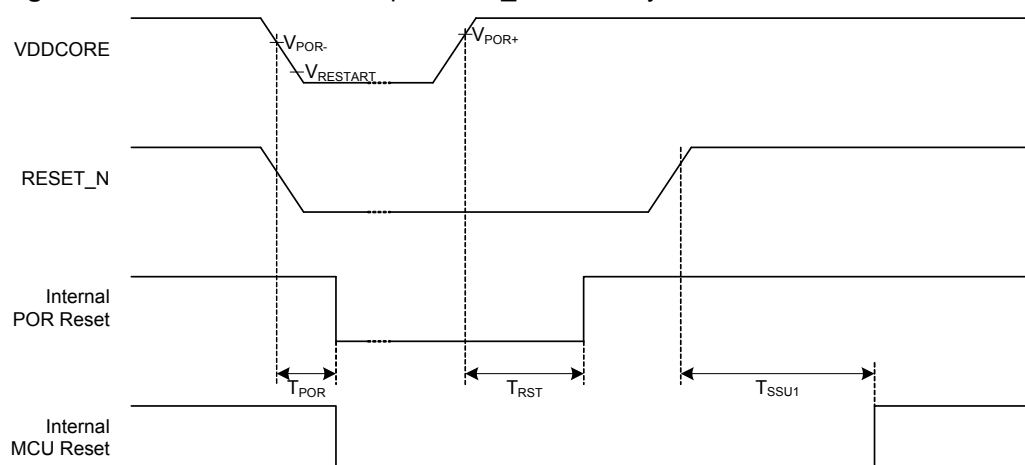
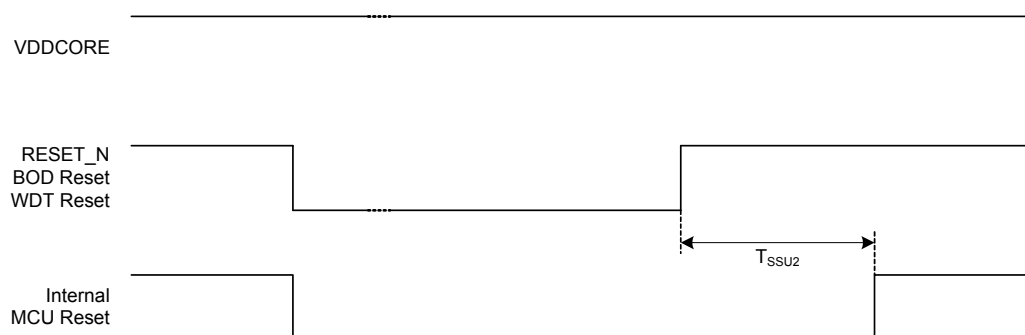

Figure 28-3. MCU Hot Start-Up



In dual supply configuration, the power up sequence must be carefully managed to ensure a safe startup of the device in all conditions.

The power up sequence must ensure that the internal logic is safely powered when the internal reset (Power On Reset) is released and that the internal Flash logic is safely powered when the CPU fetch the first instructions.

Therefore VDDCORE rise rate (VDDRR) must be equal or superior to 2.5V/ms and VDDIO must reach VDDIO mini value before 500 us ($< TRST + TSSU1$) after VDDCORE has reached V_{POR+} min value.

Figure 28-4. Dual Supply Configuration

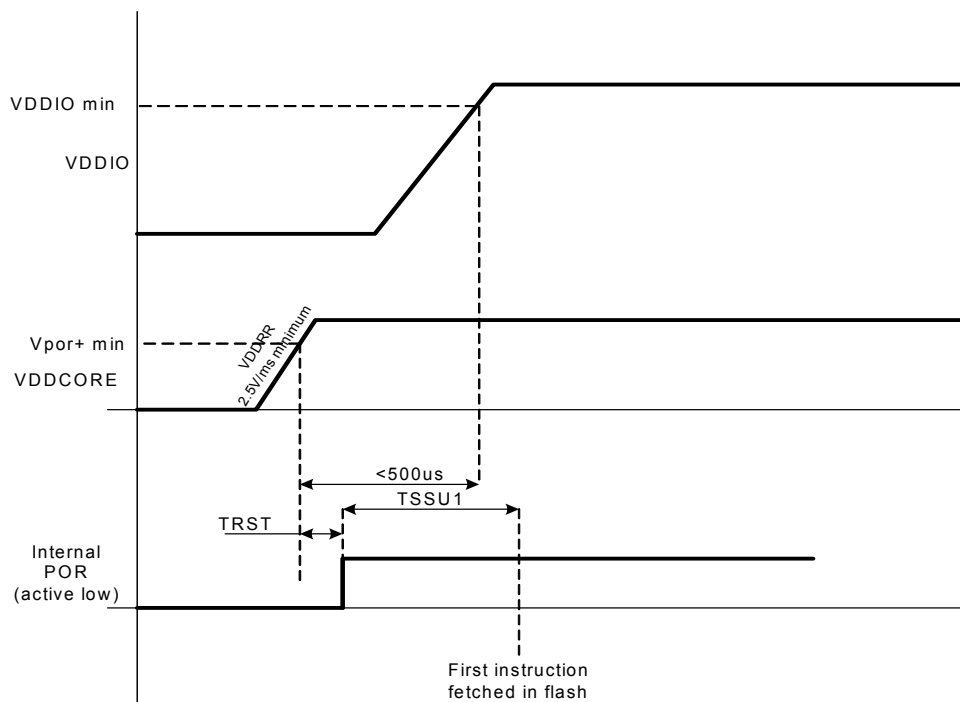

28.4.4 RESET_N Characteristics

Table 28-9. RESET_N Waveform Parameters

| Symbol | Parameter | Conditions | Min. | Typ. | Max. | Unit |
|-------------|-----------------------------|------------|------|------|------|------|
| t_{RESET} | RESET_N minimum pulse width | | 10 | | | ns |

28.5 Power Consumption

The values in [Table 28-10](#), [Table 28-11 on page 615](#) and [Table 28-12 on page 616](#) are measured values of power consumption with operating conditions as follows:

- $V_{DDIO} = V_{DDANA} = 3.3V$
- $V_{DDCORE} = V_{DDPLL} = 1.8V$
- $T_A = 25^{\circ}C, T_A = 85^{\circ}C$
- I/Os are configured in input, pull-up enabled.

Figure 28-5. Measurement Setup

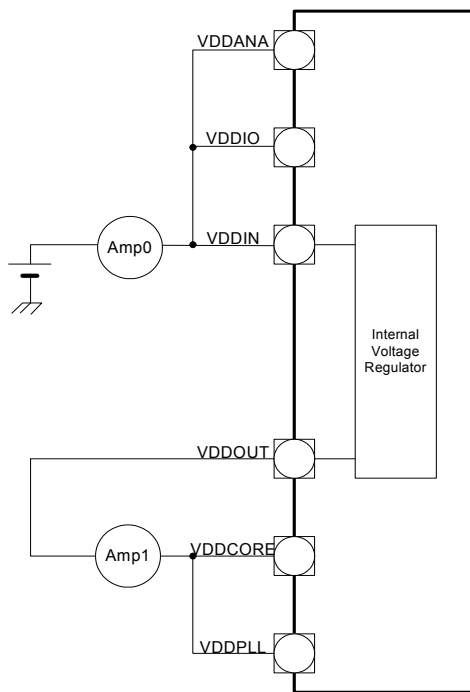

The following tables represent the power consumption measured on the power supplies.

28.5.1 Power Consumption for Different Sleep Modes

Table 28-10. Power Consumption for Different Sleep Modes for AT32UC3B064, AT32UC3B0128, AT32UC3B0256, AT32UC3B164, AT32UC3B1128, AT32UC3B1256

| Mode | Conditions | Typ. | Unit | |
|----------|---|-----------------------------|--------|----|
| Active | - CPU running a recursive Fibonacci Algorithm from flash and clocked from PLL0 at f MHz. - Voltage regulator is on. - XIN0: external clock. Xin1 Stopped. XIN32 stopped. - All peripheral clocks activated with a division by 8. - GPIOs are inactive with internal pull-up, JTAG unconnected with external pull-up and Input pins are connected to GND | $0.3xf(\text{MHz})+0.443$ | mA/MHz | |
| | Same conditions at 60 MHz | 18.5 | mA | |
| Idle | See Active mode conditions | $0.117xf(\text{MHz})+0.28$ | mA/MHz | |
| | Same conditions at 60 MHz | 7.3 | mA | |
| Frozen | See Active mode conditions | $0.058xf(\text{MHz})+0.115$ | mA/MHz | |
| | Same conditions at 60 MHz | 3.6 | mA | |
| Standby | See Active mode conditions | $0.042xf(\text{MHz})+0.115$ | mA/MHz | |
| | Same conditions at 60 MHz | 2.7 | mA | |
| Stop | - CPU running in sleep mode - XIN0, Xin1 and XIN32 are stopped. - All peripheral clocks are deactivated. - GPIOs are inactive with internal pull-up, JTAG unconnected with external pull-up and Input pins are connected to GND. | 37.8 | μA | |
| Deepstop | See Stop mode conditions | 24.9 | μA | |
| Static | See Stop mode conditions | Voltage Regulator On | 13.9 | μA |
| | | Voltage Regulator Off | 8.9 | μA |

Notes: 1. Core frequency is generated from XIN0 using the PLL so that $140 \text{ MHz} < f_{\text{PLL0}} < 160 \text{ MHz}$ and $10 \text{ MHz} < f_{\text{XIN0}} < 12 \text{ MHz}$.

Table 28-11. Power Consumption for Different Sleep Modes for AT32UC3B0512, AT32UC3B1512

| Mode | Conditions | Typ. | Unit |
|--------|---|-----------------------------|--------|
| Active | - CPU running a recursive Fibonacci Algorithm from flash and clocked from PLL0 at f MHz. - Voltage regulator is on. - XIN0: external clock. Xin1 Stopped. XIN32 stopped. - All peripheral clocks activated with a division by 8. - GPIOs are inactive with internal pull-up, JTAG unconnected with external pull-up and Input pins are connected to GND | $0.359xf(\text{MHz})+1.53$ | mA/MHz |
| | Same conditions at 60 MHz | 24 | mA |
| Idle | See Active mode conditions | $0.146xf(\text{MHz})+0.291$ | mA/MHz |
| | Same conditions at 60 MHz | 9 | mA |

Table 28-11. Power Consumption for Different Sleep Modes for AT32UC3B0512, AT32UC3B1512

| Mode | Conditions | Typ. | Unit |
|----------|--|---------------------------------------|--------|
| Frozen | See Active mode conditions | $0.0723 \times f(\text{MHz}) + 0.156$ | mA/MHz |
| | Same conditions at 60 MHz | 4.5 | mA |
| Standby | See Active mode conditions | $0.0537 \times f(\text{MHz}) + 0.166$ | mA/MHz |
| | Same conditions at 60 MHz | 3.4 | mA |
| Stop | <ul style="list-style-type: none"> - CPU running in sleep mode - XIN0, Xin1 and XIN32 are stopped. - All peripheral clocks are desactivated. - GPIOs are inactive with internal pull-up, JTAG unconnected with external pull-up and Input pins are connected to GND. | 62 | μA |
| Deepstop | See Stop mode conditions | 30 | μA |
| Static | See Stop mode conditions | Voltage Regulator On | 15.5 |
| | | Voltage Regulator Off | 7.5 |

Notes: 1. Core frequency is generated from XIN0 using the PLL so that $140 \text{ MHz} < f_{\text{PLL0}} < 160 \text{ MHz}$ and $10 \text{ MHz} < f_{\text{XIN0}} < 12 \text{ MHz}$.

Table 28-12. Peripheral Interface Power Consumption in Active Mode

| Peripheral | Conditions | Consumption | Unit |
|------------|--|-------------|--------|
| INTC | AT32UC3B064 AT32UC3B0128 AT32UC3B0256 AT32UC3B164 AT32UC3B1128 AT32UC3B1256 AT32UC3B0512 AT32UC3B1512 | 20 | μA/MHz |
| GPIO | | 16 | |
| PDCA | | 12 | |
| USART | | 14 | |
| USB | | 23 | |
| ADC | | 8 | |
| TWI | | 7 | |
| PWM | | 18 | |
| SPI | | 8 | |
| SSC | | 11 | |
| TC | | 11 | |
| ABDAC | | 6 | |

28.6 System Clock Characteristics

These parameters are given in the following conditions:

- $V_{DDCORE} = 1.8V$
- Ambient Temperature = 25°C

28.6.1 CPU/HSB Clock Characteristics

Table 28-13. Core Clock Waveform Parameters

| Symbol | Parameter | Conditions | Min. | Typ. | Max. | Unit |
|-----------------|---------------------|------------|------|------|------|------|
| $1/(t_{CPCPU})$ | CPU Clock Frequency | | | | 60 | MHz |
| t_{CPCPU} | CPU Clock Period | | 16.6 | | | ns |

28.6.2 PBA Clock Characteristics

Table 28-14. PBA Clock Waveform Parameters

| Symbol | Parameter | Conditions | Min. | Typ. | Max. | Unit |
|-----------------|---------------------|------------|------|------|------|------|
| $1/(t_{CPPBA})$ | PBA Clock Frequency | | | | 60 | MHz |
| t_{CPPBA} | PBA Clock Period | | 16.6 | | | ns |

28.6.3 PBB Clock Characteristics

Table 28-15. PBB Clock Waveform Parameters

| Symbol | Parameter | Conditions | Min. | Typ. | Max. | Unit |
|-----------------|---------------------|------------|------|------|------|------|
| $1/(t_{CPPBB})$ | PBB Clock Frequency | | | | 60 | MHz |
| t_{CPPBB} | PBB Clock Period | | 16.6 | | | ns |

28.7 Oscillator Characteristics

The following characteristics are applicable to the operating temperature range: $T_A = -40^{\circ}\text{C}$ to 85°C and worst case of power supply, unless otherwise specified.

28.7.1 Slow Clock RC Oscillator

Table 28-16. RC Oscillator Frequency

| Symbol | Parameter | Conditions | Min. | Typ. | Max. | Unit |
|----------|-------------------------|---|------|-------|------|------|
| F_{RC} | RC Oscillator Frequency | Calibration point: $T_A = 85^{\circ}\text{C}$ | | 115.2 | 116 | KHz |
| | | $T_A = 25^{\circ}\text{C}$ | | 112 | | KHz |
| | | $T_A = -40^{\circ}\text{C}$ | 105 | 108 | | KHz |

28.7.2 32 KHz Oscillator

Table 28-17. 32 KHz Oscillator Characteristics

| Symbol | Parameter | Conditions | Min. | Typ. | Max. | Unit |
|-------------------|--------------------------------------|---|--------------|--------|--------------|---------------|
| $1/(t_{CP32KHz})$ | Oscillator Frequency | External clock on XIN32 | | | 30 | MHz |
| | | Crystal | | 32 768 | | Hz |
| C_L | Equivalent Load Capacitance | | 6 | | 12.5 | pF |
| ESR | Crystal Equivalent Series Resistance | | | | 100 | K Ω |
| t_{ST} | Startup Time | $C_L = 6\text{pF}^{(1)}$ $C_L = 12.5\text{pF}^{(1)}$ | | | 600 1200 | ms |
| t_{CH} | XIN32 Clock High Half-period | | $0.4 t_{CP}$ | | $0.6 t_{CP}$ | |
| t_{CL} | XIN32 Clock Low Half-period | | $0.4 t_{CP}$ | | $0.6 t_{CP}$ | |
| C_{IN} | XIN32 Input Capacitance | | | | 5 | pF |
| I_{OSC} | Current Consumption | Active mode | | | 1.8 | μA |
| | | Standby mode | | | 0.1 | μA |

Note: 1. C_L is the equivalent load capacitance.

28.7.3 Main Oscillators

Table 28-18. Main Oscillators Characteristics

| Symbol | Parameter | Conditions | Min. | Typ. | Max. | Unit |
|------------------|---|--|--------------|-----------------------|---------------------|----------|
| $1/(t_{CPMAIN})$ | Oscillator Frequency | External clock on XIN | | | 50 | MHz |
| | | Crystal | 0.4 | | 20 | MHz |
| C_{L1}, C_{L2} | Internal Load Capacitance ($C_{L1} = C_{L2}$) | | | 7 | | pF |
| ESR | Crystal Equivalent Series Resistance | | | | 75 | Ω |
| | Duty Cycle | | 40 | 50 | 60 | % |
| t_{ST} | Startup Time | f = 400 KHz f = 8 MHz f = 16 MHz f = 20 MHz | | | 25 4 1.4 1 | ms |
| t_{CH} | XIN Clock High Half-period | | $0.4 t_{CP}$ | | $0.6 t_{CP}$ | |
| t_{CL} | XIN Clock Low Half-period | | $0.4 t_{CP}$ | | $0.6 t_{CP}$ | |
| C_{IN} | XIN Input Capacitance | | | 7 | | pF |
| I_{OSC} | Current Consumption | Active mode at 400 KHz. Gain = G0 Active mode at 8 MHz. Gain = G1 Active mode at 16 MHz. Gain = G2 Active mode at 20 MHz. Gain = G3 | | 30 45 95 205 | | μA |

28.7.4 Phase Lock Loop

Table 28-19. Phase Lock Loop Characteristics

| Symbol | Parameter | Conditions | Min. | Typ. | Max. | Unit |
|-----------|----------------------|--|------|-------------------|------|---------|
| F_{OUT} | VCO Output Frequency | | 80 | | 240 | MHz |
| F_{IN} | Input Frequency | | 4 | | 16 | MHz |
| I_{PLL} | Current Consumption | Active mode $F_{VCO}@96$ MHz Active mode $F_{VCO}@128$ MHz Active mode $F_{VCO}@160$ MHz | | 320 410 450 | | μA |
| | | Standby mode | | 5 | | μA |

28.8 ADC Characteristics

Table 28-20. Channel Conversion Time and ADC Clock

| Parameter | Conditions | Min. | Typ. | Max. | Unit |
|---------------------------------|------------------------|------|------|--------------------|------|
| ADC Clock Frequency | 10-bit resolution mode | | | 5 | MHz |
| ADC Clock Frequency | 8-bit resolution mode | | | 8 | MHz |
| Startup Time | Return from Idle Mode | | | 20 | μs |
| Track and Hold Acquisition Time | | 600 | | | ns |
| Track and Hold Input Resistor | | | 350 | | Ω |
| Track and Hold Capacitor | | | 12 | | pF |
| Conversion Time | ADC Clock = 5 MHz | | | 2 | μs |
| | ADC Clock = 8 MHz | | | 1.25 | μs |
| Throughput Rate | ADC Clock = 5 MHz | | | 384 ⁽¹⁾ | kSPS |
| | ADC Clock = 8 MHz | | | 533 ⁽²⁾ | kSPS |

Notes: 1. Corresponds to 13 clock cycles: 3 clock cycles for track and hold acquisition time and 10 clock cycles for conversion.
 2. Corresponds to 15 clock cycles: 5 clock cycles for track and hold acquisition time and 10 clock cycles for conversion.

Table 28-21. External Voltage Reference Input

| Parameter | Conditions | Min. | Typ. | Max. | Unit |
|-------------------------------|--------------------------------------|------|------|--------|------|
| ADVREF Input Voltage Range | ⁽¹⁾ | 2.6 | | VDDANA | V |
| ADVREF Average Current | On 13 samples with ADC Clock = 5 MHz | | 200 | 250 | μA |
| Current Consumption on VDDANA | On 13 samples with ADC Clock = 5 MHz | | | 1 | mA |

Note: 1. ADVREF should be connected to GND to avoid extra consumption in case ADC is not used.

Table 28-22. Analog Inputs

| Parameter | Conditions | Min. | Typ. | Max. | Unit |
|-----------------------|------------|------|------|---------------------|------|
| Input Voltage Range | | 0 | | V _{ADVREF} | V |
| Input Leakage Current | | | | 1 | μA |
| Input Capacitance | | | 7 | | pF |

Table 28-23. Transfer Characteristics in 8-bit Mode

| Parameter | Conditions | Min. | Typ. | Max. | Unit |
|------------------------|-------------------|------|------|------|------|
| Resolution | | | 8 | | Bit |
| Absolute Accuracy | ADC Clock = 5 MHz | | | 0.8 | LSB |
| | ADC Clock = 8 MHz | | | 1.5 | LSB |
| Integral Non-linearity | ADC Clock = 5 MHz | | 0.35 | 0.5 | LSB |
| | ADC Clock = 8 MHz | | 0.5 | 1.0 | LSB |

Table 28-23. Transfer Characteristics in 8-bit Mode

| Parameter | Conditions | Min. | Typ. | Max. | Unit |
|----------------------------|-------------------|------|------|------|------|
| Differential Non-linearity | ADC Clock = 5 MHz | | 0.3 | 0.5 | LSB |
| | ADC Clock = 8 MHz | | 0.5 | 1.0 | LSB |
| Offset Error | ADC Clock = 5 MHz | -0.5 | | 0.5 | LSB |
| Gain Error | ADC Clock = 5 MHz | -0.5 | | 0.5 | LSB |

Table 28-24. Transfer Characteristics in 10-bit Mode

| Parameter | Conditions | Min. | Typ. | Max. | Unit |
|----------------------------|---------------------|------|------|------|------|
| Resolution | | | 10 | | Bit |
| Absolute Accuracy | ADC Clock = 5 MHz | | | 3 | LSB |
| Integral Non-linearity | ADC Clock = 5 MHz | | 1.5 | 2 | LSB |
| Differential Non-linearity | ADC Clock = 5 MHz | | 1 | 2 | LSB |
| | ADC Clock = 2.5 MHz | | 0.6 | 1 | LSB |
| Offset Error | ADC Clock = 5 MHz | -2 | | 2 | LSB |
| Gain Error | ADC Clock = 5MHz | -2 | | 2 | LSB |

28.9 USB Transceiver Characteristics

28.9.1 Electrical Characteristics

Table 28-25. Electrical Parameters

| Symbol | Parameter | Conditions | Min. | Typ. | Max. | Unit |
|------------------|--|--|------|------|------|----------|
| R _{EXT} | Recommended external USB series resistor | In series with each USB pin with $\pm 5\%$ | | 39 | | Ω |

The USB on-chip buffers comply with the Universal Serial Bus (USB) v2.0 standard. All AC parameters related to these buffers can be found within the USB 2.0 electrical specifications.

28.10 JTAG Characteristics

28.10.1 JTAG Timing

Figure 28-6. JTAG Interface Signals

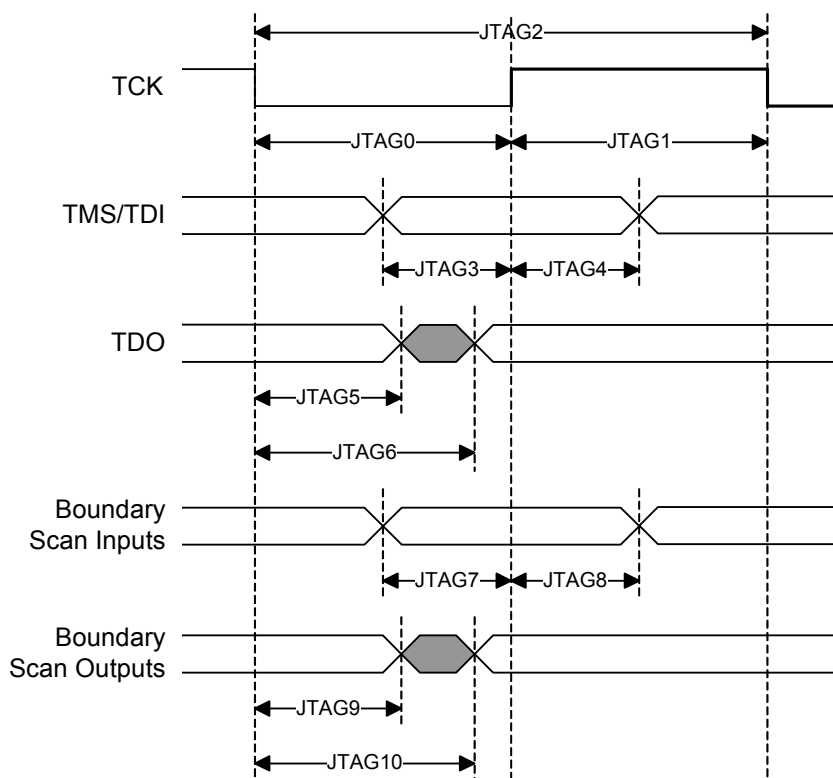

Table 28-26. JTAG Timings⁽¹⁾

| Symbol | Parameter | Conditions | Min | Max | Units |
|--------|------------------------------------|---|------|------|-------|
| JTAG0 | TCK Low Half-period | V _{VDDIO} from 3.0V to 3.6V, maximum external capacitor = 40pF | 23.2 | | ns |
| JTAG1 | TCK High Half-period | | 8.8 | | ns |
| JTAG2 | TCK Period | | 32.0 | | ns |
| JTAG3 | TDI, TMS Setup before TCK High | | 3.9 | | ns |
| JTAG4 | TDI, TMS Hold after TCK High | | 0.6 | | ns |
| JTAG5 | TDO Hold Time | | 4.5 | | ns |
| JTAG6 | TCK Low to TDO Valid | | | 23.2 | ns |
| JTAG7 | Boundary Scan Inputs Setup Time | | 0 | | ns |
| JTAG8 | Boundary Scan Inputs Hold Time | | 5.0 | | ns |
| JTAG9 | Boundary Scan Outputs Hold Time | | 8.7 | | ns |
| JTAG10 | TCK to Boundary Scan Outputs Valid | | 17.7 | ns | |

Note: 1. These values are based on simulation and characterization of other AVR microcontrollers manufactured in the same pro-cess technology. These values are not covered by test limits in production.

28.11 SPI Characteristics

Figure 28-7. SPI Master mode with (CPOL = NCPHA = 0) or (CPOL= NCPHA= 1)

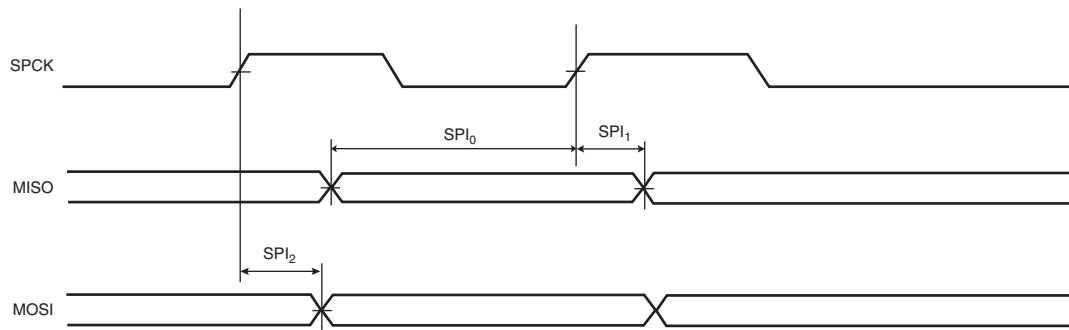

Figure 28-8. SPI Master mode with (CPOL=0 and NCPHA=1) or (CPOL=1 and NCPHA=0)

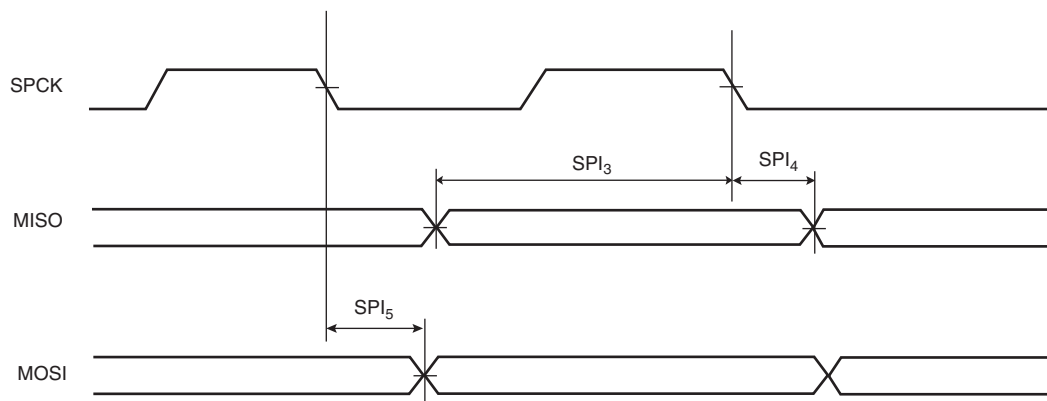

Figure 28-9. SPI Slave mode with (CPOL=0 and NCPHA=1) or (CPOL=1 and NCPHA=0)

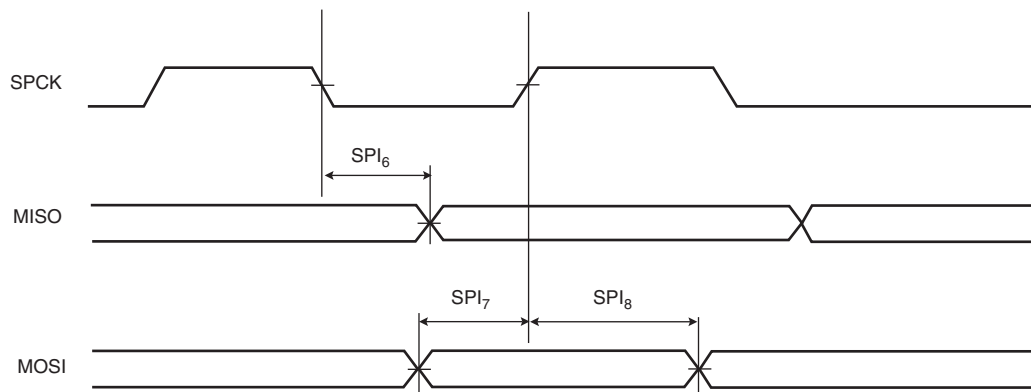

Figure 28-10. SPI Slave mode with (CPOL = NCPHA = 0) or (CPOL= NCPHA= 1)

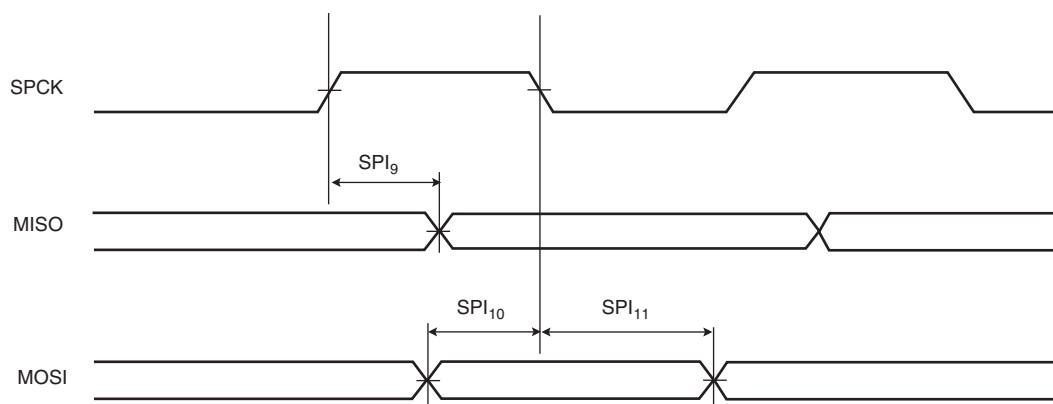

Table 28-27. SPI Timings

| Symbol | Parameter | Conditions | Min. | Max. | Unit |
|-------------------|--|----------------------------|---|------|------|
| SPI ₀ | MISO Setup time before SPCK rises (master) | 3.3V domain ⁽¹⁾ | 22 + (t _{CPMCK})/2 ⁽²⁾ | | ns |
| SPI ₁ | MISO Hold time after SPCK rises (master) | 3.3V domain ⁽¹⁾ | 0 | | ns |
| SPI ₂ | SPCK rising to MOSI Delay (master) | 3.3V domain ⁽¹⁾ | | 7 | ns |
| SPI ₃ | MISO Setup time before SPCK falls (master) | 3.3V domain ⁽¹⁾ | 22 + (t _{CPMCK})/2 ⁽²⁾ | | ns |
| SPI ₄ | MISO Hold time after SPCK falls (master) | 3.3V domain ⁽¹⁾ | 0 | | ns |
| SPI ₅ | SPCK falling to MOSI Delay (master) | 3.3V domain ⁽¹⁾ | | 7 | ns |
| SPI ₆ | SPCK falling to MISO Delay (slave) | 3.3V domain ⁽¹⁾ | | 26.5 | ns |
| SPI ₇ | MOSI Setup time before SPCK rises (slave) | 3.3V domain ⁽¹⁾ | 0 | | ns |
| SPI ₈ | MOSI Hold time after SPCK rises (slave) | 3.3V domain ⁽¹⁾ | 1.5 | | ns |
| SPI ₉ | SPCK rising to MISO Delay (slave) | 3.3V domain ⁽¹⁾ | | 27 | ns |
| SPI ₁₀ | MOSI Setup time before SPCK falls (slave) | 3.3V domain ⁽¹⁾ | 0 | | ns |
| SPI ₁₁ | MOSI Hold time after SPCK falls (slave) | 3.3V domain ⁽¹⁾ | 1 | | ns |

- Notes: 1. 3.3V domain: V_{VDDIO} from 3.0V to 3.6V, maximum external capacitor = 40 pF.
 2. t_{CPMCK}: Master Clock period in ns.

28.12 Flash Memory Characteristics

The following table gives the device maximum operating frequency depending on the field FWS of the Flash FSR register. This field defines the number of wait states required to access the Flash Memory. Flash operating frequency equals the CPU/HSB frequency.

Table 28-28. Flash Operating Frequency

| Symbol | Parameter | Conditions | Min. | Typ. | Max. | Unit |
|------------------|---------------------------|------------|------|------|------|------|
| F _{FOP} | Flash Operating Frequency | FWS = 0 | | | 33 | MHz |
| | | FWS = 1 | | | 60 | MHz |

Table 28-29. Programming Time

| Symbol | Parameter | Conditions | Min. | Typ. | Max. | Unit |
|------------------|-----------------------|------------|------|------|------|------|
| T _{FPP} | Page Programming Time | | | 4 | | ms |
| T _{FFP} | Fuse Programming Time | | | 0.5 | | ms |
| T _{FCE} | Chip Erase Time | | | 4 | | ms |

Table 28-30. Flash Parameters

| Symbol | Parameter | Conditions | Min. | Typ. | Max. | Unit |
|---------------------|-----------------------------------|------------|------|------|------|-------|
| N _{FARRAY} | Flash Array Write/Erase cycle | | | | 100K | Cycle |
| N _{FFUSE} | General Purpose Fuses write cycle | | | | 1000 | Cycle |
| T _{FDR} | Flash Data Retention Time | | | 15 | | Year |

29. Mechanical Characteristics

29.1 Thermal Considerations

29.1.1 Thermal Data

Table 29-1 summarizes the thermal resistance data depending on the package.

Table 29-1. Thermal Resistance Data

| Symbol | Parameter | Condition | Package | Typ | Unit |
|---------------|--|-----------|---------|------|------|
| θ_{JA} | Junction-to-ambient thermal resistance | Still Air | TQFP64 | 49.6 | °C/W |
| θ_{JC} | Junction-to-case thermal resistance | | TQFP64 | 13.5 | |
| θ_{JA} | Junction-to-ambient thermal resistance | Still Air | TQFP48 | 51.1 | °C/W |
| θ_{JC} | Junction-to-case thermal resistance | | TQFP48 | 13.7 | |

29.1.2 Junction Temperature

The average chip-junction temperature, T_J , in °C can be obtained from the following:

- $T_J = T_A + (P_D \times \theta_{JA})$
- $T_J = T_A + (P_D \times (\theta_{HEATSINK} + \theta_{JC}))$

where:

- θ_{JA} = package thermal resistance, Junction-to-ambient (°C/W), provided in [Table 29-1 on page 627](#).
- θ_{JC} = package thermal resistance, Junction-to-case thermal resistance (°C/W), provided in [Table 29-1 on page 627](#).
- $\theta_{HEAT\ SINK}$ = cooling device thermal resistance (°C/W), provided in the device datasheet.
- P_D = device power consumption (W) estimated from data provided in the section "[Power Consumption](#)" on page 614.
- T_A = ambient temperature (°C).

From the first equation, the user can derive the estimated lifetime of the chip and decide if a cooling device is necessary or not. If a cooling device is to be fitted on the chip, the second equation should be used to compute the resulting average chip-junction temperature T_J in °C.

29.2 Package Drawings

Figure 29-1. TQFP-64 package drawing

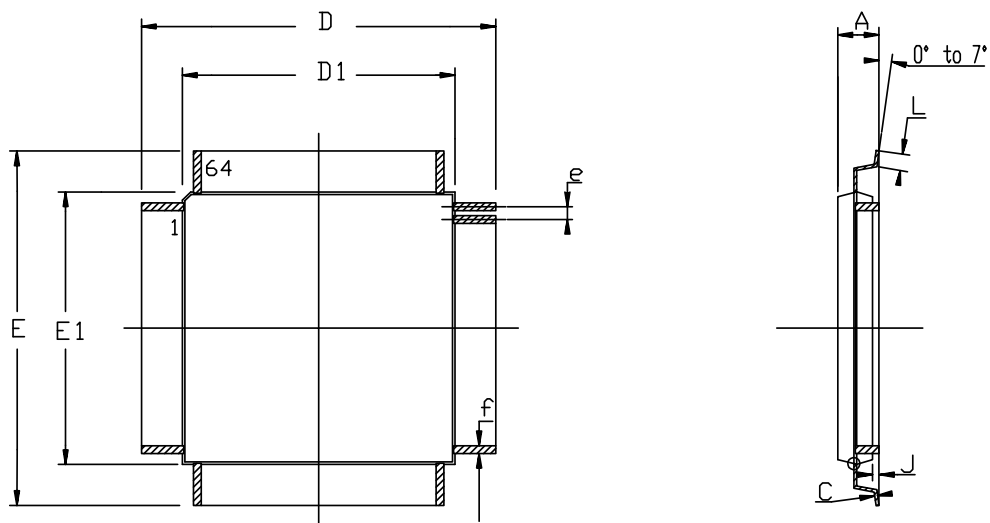

COMMON DIMENSIONS IN MM

| SYMBOL | Min | Max | NOTES |
|--------|-----------|------|-------|
| A | ---- | 1.20 | |
| A1 | 0.95 | 1.05 | |
| C | 0.09 | 0.20 | |
| D | 12.00 BSC | | |
| D1 | 10.00 BSC | | |
| E | 12.00 BSC | | |
| E1 | 10.00 BSC | | |
| J | 0.05 | 0.15 | |
| L | 0.45 | 0.75 | |
| e | 0.50 BSC | | |
| f | 0.17 | 0.27 | |

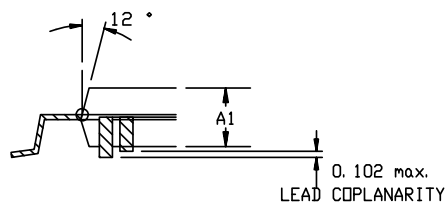

Table 29-2. Device and Package Maximum Weight

| | |
|--------|--------|
| Weight | 300 mg |
|--------|--------|

Table 29-3. Package Characteristics

| | |
|----------------------------|----------------------|
| Moisture Sensitivity Level | Jedec J-STD-20D-MSL3 |
|----------------------------|----------------------|

Table 29-4. Package Reference

| | |
|-------------------------|--------|
| JEDEC Drawing Reference | MS-026 |
| JESD97 Classification | e3 |

Figure 29-2. TQFP-48 package drawing

DRAWINGS NOT SCALED

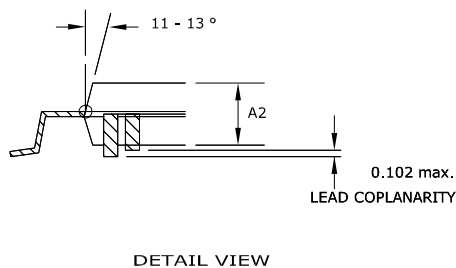
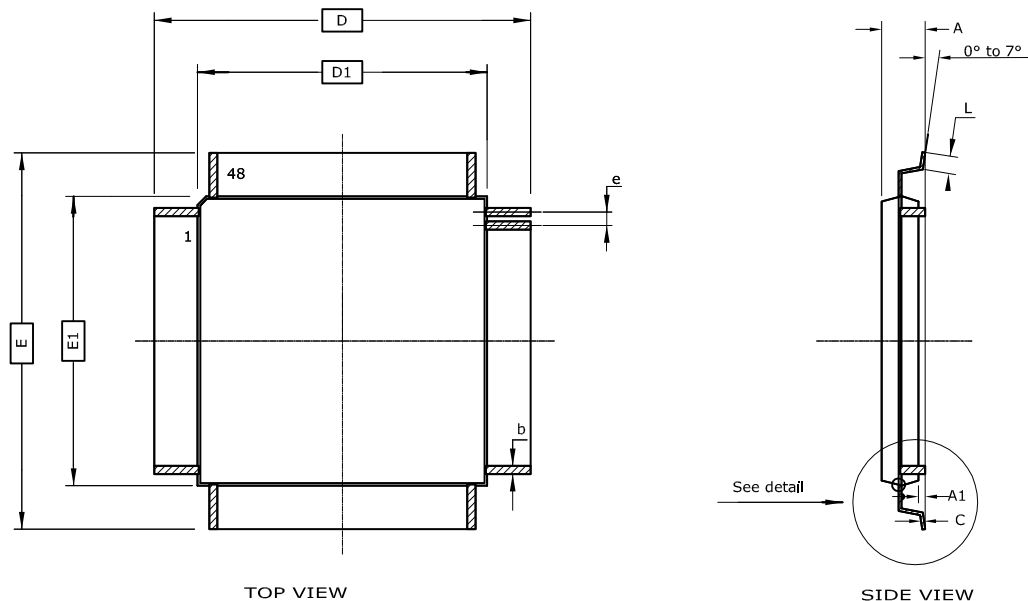

COMMON DIMENSIONS
(Unit of Measure = mm)

| SYMBOL | MIN | NOM | MAX | NOTE |
|--------|----------|-------|------|------|
| A | ----- | ----- | 1.20 | |
| A1 | 0.05 | ----- | 0.15 | |
| A2 | 0.95 | ----- | 1.05 | |
| C | 0.09 | ----- | 0.20 | |
| D/E | 9.00 BSC | | | |
| D1/E1 | 7.00 BSC | | | |
| L | 0.45 | ----- | 0.75 | |
| b | 0.17 | ----- | 0.27 | |
| e | 0.50 BSC | | | |

- Notes :
1. This drawing is for general information only. Refer to JEDEC Drawing MS-026, Variation ABC.
 2. Dimensions D1 and E1 do not include mold protrusion. Allowable protrusion is 0.25mm per side. Dimensions D1 and E1 are maximum plastic body size dimensions including mold mismatch.
 3. Lead coplanarity is 0.10mm maximum.

Table 29-5. Device and Package Maximum Weight

| | |
|--------|--------|
| Weight | 100 mg |
|--------|--------|

Table 29-6. Package Characteristics

| | |
|----------------------------|----------------------|
| Moisture Sensitivity Level | Jedec J-STD-20D-MSL3 |
|----------------------------|----------------------|

Table 29-7. Package Reference

| | |
|-------------------------|--------|
| JEDEC Drawing Reference | MS-026 |
| JESD97 Classification | e3 |

Figure 29-3. QFN-64 package drawing

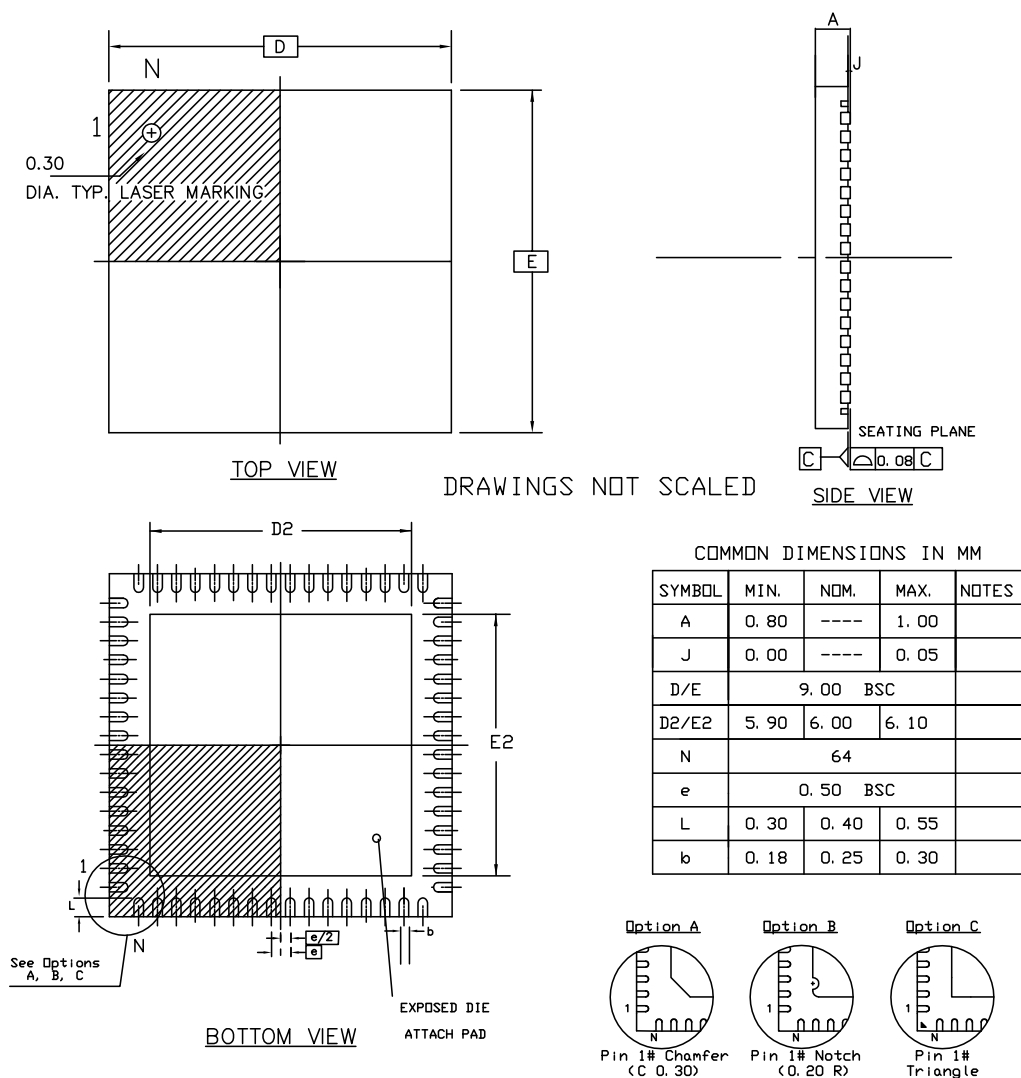

Compliant JEDEC Standard M0-220 variation VMMD-3

Table 29-8. Device and Package Maximum Weight

| | |
|--------|--------|
| Weight | 200 mg |
|--------|--------|

Table 29-9. Package Characteristics

| | |
|----------------------------|----------------------|
| Moisture Sensitivity Level | Jedec J-STD-20D-MSL3 |
|----------------------------|----------------------|

Table 29-10. Package Reference

| | |
|-------------------------|--------|
| JEDEC Drawing Reference | M0-220 |
| JESD97 Classification | e3 |

Figure 29-4. QFN-48 package drawing

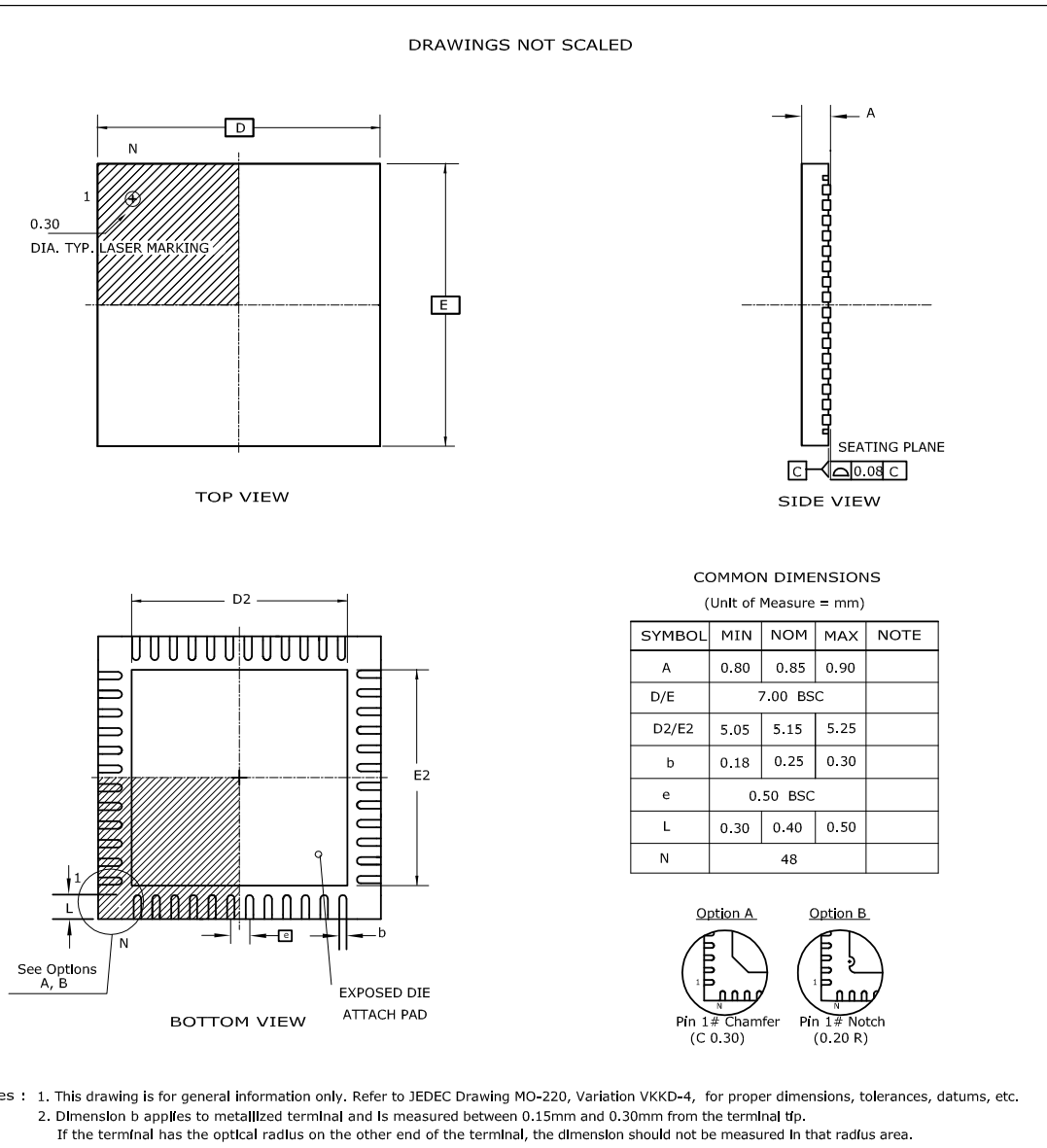

Table 29-11. Device and Package Maximum Weight

| | |
|--------|--------|
| Weight | 100 mg |
|--------|--------|

Table 29-12. Package Characteristics

| | |
|----------------------------|----------------------|
| Moisture Sensitivity Level | Jedec J-STD-20D-MSL3 |
|----------------------------|----------------------|

Table 29-13. Package Reference

| | |
|-------------------------|--------|
| JEDEC Drawing Reference | M0-220 |
| JESD97 Classification | e3 |

29.3 Soldering Profile

Table 29-14 gives the recommended soldering profile from J-STD-20.

Table 29-14. Soldering Profile

| Profile Feature | Green Package |
|--|------------------------|
| Average Ramp-up Rate (217°C to Peak) | 3°C/s |
| Preheat Temperature 175°C ±25°C | Min. 150°C, Max. 200°C |
| Temperature Maintained Above 217°C | 60-150s |
| Time within 5-C of Actual Peak Temperature | 30s |
| Peak Temperature Range | 260°C |
| Ramp-down Rate | 6°C/s |
| Time 25-C to Peak Temperature | Max. 8mn |

Note: It is recommended to apply a soldering temperature higher than 250°C. A maximum of three reflow passes is allowed per component.

30. Ordering Information

| Device | Ordering Code | Package | Conditioning | Temperature Operating Range |
|---------------------|--------------------|---------|--------------|-----------------------------|
| AT32UC3B0512 | AT32UC3B0512-A2UES | TQFP 64 | - | Industrial (-40°C to 85°C) |
| | AT32UC3B0512-A2UR | TQFP 64 | Reel | Industrial (-40°C to 85°C) |
| | AT32UC3B0512-A2UT | TQFP 64 | Tray | Industrial (-40°C to 85°C) |
| | AT32UC3B0512-Z2UES | QFN 64 | - | Industrial (-40°C to 85°C) |
| | AT32UC3B0512-Z2UR | QFN 64 | Reel | Industrial (-40°C to 85°C) |
| | AT32UC3B0512-Z2UT | QFN 64 | Tray | Industrial (-40°C to 85°C) |
| AT32UC3B0256 | AT32UC3B0256-A2UT | TQFP 64 | Tray | Industrial (-40°C to 85°C) |
| | AT32UC3B0256-A2UR | TQFP 64 | Reel | Industrial (-40°C to 85°C) |
| | AT32UC3B0256-Z2UT | QFN 64 | Tray | Industrial (-40°C to 85°C) |
| | AT32UC3B0256-Z2UR | QFN 64 | Reel | Industrial (-40°C to 85°C) |
| AT32UC3B0128 | AT32UC3B0128-A2UT | TQFP 64 | Tray | Industrial (-40°C to 85°C) |
| | AT32UC3B0128-A2UR | TQFP 64 | Reel | Industrial (-40°C to 85°C) |
| | AT32UC3B0128-Z2UT | QFN 64 | Tray | Industrial (-40°C to 85°C) |
| | AT32UC3B0128-Z2UR | QFN 64 | Reel | Industrial (-40°C to 85°C) |
| AT32UC3B064 | AT32UC3B064-A2UT | TQFP 64 | Tray | Industrial (-40°C to 85°C) |
| | AT32UC3B064-A2UR | TQFP 64 | Reel | Industrial (-40°C to 85°C) |
| | AT32UC3B064-Z2UT | QFN 64 | Tray | Industrial (-40°C to 85°C) |
| | AT32UC3B064-Z2UR | QFN 64 | Reel | Industrial (-40°C to 85°C) |
| AT32UC3B1512 | AT32UC3B1512-Z1UT | QFN 48 | - | Industrial (-40°C to 85°C) |
| | AT32UC3B1512-Z1UR | QFN 48 | - | Industrial (-40°C to 85°C) |
| AT32UC3B1256 | AT32UC3B1256-AUT | TQFP 48 | Tray | Industrial (-40°C to 85°C) |
| | AT32UC3B1256-AUR | TQFP 48 | Reel | Industrial (-40°C to 85°C) |
| | AT32UC3B1256-Z1UT | QFN 48 | Tray | Industrial (-40°C to 85°C) |
| | AT32UC3B1256-Z1UR | QFN 48 | Reel | Industrial (-40°C to 85°C) |
| AT32UC3B1128 | AT32UC3B1128-AUT | TQFP 48 | Tray | Industrial (-40°C to 85°C) |
| | AT32UC3B1128-AUR | TQFP 48 | Reel | Industrial (-40°C to 85°C) |
| | AT32UC3B1128-Z1UT | QFN 48 | Tray | Industrial (-40°C to 85°C) |
| | AT32UC3B1128-Z1UR | QFN 48 | Reel | Industrial (-40°C to 85°C) |
| AT32UC3B164 | AT32UC3B164-AUT | TQFP 48 | Tray | Industrial (-40°C to 85°C) |
| | AT32UC3B164-AUR | TQFP 48 | Reel | Industrial (-40°C to 85°C) |
| | AT32UC3B164-Z1UT | QFN 48 | Tray | Industrial (-40°C to 85°C) |
| | AT32UC3B164-Z1UR | QFN 48 | Reel | Industrial (-40°C to 85°C) |

31. Errata

31.1 AT32UC3B0512, AT32UC3B1512

31.1.1 Rev D

- PWM

1. **PWM channel interrupt enabling triggers an interrupt**
 When enabling a PWM channel that is configured with center aligned period (CALG=1), an interrupt is signalled.
Fix/Workaround
 When using center aligned mode, enable the channel and read the status before channel interrupt is enabled.
2. **PWN counter restarts at 0x0001**
 The PWM counter restarts at 0x0001 and not 0x0000 as specified. Because of this the first PWM period has one more clock cycle.
Fix/Workaround
 - The first period is 0x0000, 0x0001, ..., period.
 - Consecutive periods are 0x0001, 0x0002, ..., period.
3. **PWM update period to a 0 value does not work**
 It is impossible to update a period equal to 0 by the using the PWM update register (PWM_CUPD).
Fix/Workaround
 Do not update the PWM_CUPD register with a value equal to 0.
4. **SPI**
5. **SPI Slave / PDCA transfer: no TX UNDERRUN flag**
 There is no TX UNDERRUN flag available, therefore in SPI slave mode, there is no way to be informed of a character lost in transmission.
Fix/Workaround
 For PDCA transfer: none.
6. **SPI bad serial clock generation on 2nd chip_select when SCBR=1, CPOL=1, and NCPHA=0**
 When multiple chip selects (CS) are in use, if one of the baudrates equal 1 while one (CSRn.SCBR=1) of the others do not equal 1, and CSRn.CPOL=1 and CSRn.NCPHA=0, then an additional pulse will be generated on SCK.
Fix/Workaround
 When multiple CS are in use, if one of the baudrates equals 1, the others must also equal 1 if CSRn.CPOL=1 and CSRn.NCPHA=0.

7. SPI Glitch on RXREADY flag in slave mode when enabling the SPI or during the first transfer

In slave mode, the SPI can generate a false RXREADY signal during enabling of the SPI or during the first transfer.

Fix/Workaround

1. Set slave mode, set required CPOL/CPHA.
2. Enable SPI.
3. Set the polarity CPOL of the line in the opposite value of the required one.
4. Set the polarity CPOL to the required one.
5. Read the RXHOLDING register.

Transfers can now begin and RXREADY will now behave as expected.

8. SPI disable does not work in SLAVE mode

SPI disable does not work in SLAVE mode.

Fix/Workaround

Read the last received data, then perform a software reset by writing a one to the Software Reset bit in the Control Register (CR.SWRST).

9. SPI data transfer hangs with CSR0.CSAAT==1 and MR.MODFDIS==0

When CSR0.CSAAT==1 and mode fault detection is enabled (MR.MODFDIS==0), the SPI module will not start a data transfer.

Fix/Workaround

Disable mode fault detection by writing a one to MR.MODFDIS.

10. Disabling SPI has no effect on the SR.TDRE bit

Disabling SPI has no effect on the SR.TDRE bit whereas the write data command is filtered when SPI is disabled. Writing to TDR when SPI is disabled will not clear SR.TDRE. If SPI is disabled during a PDCA transfer, the PDCA will continue to write data to TDR until its buffer is empty, and this data will be lost.

Fix/Workaround

Disable the PDCA, add two NOPs, and disable the SPI. To continue the transfer, enable the SPI and PDCA.

11. Power Manager

12. If the BOD level is higher than VDDCORE, the part is constantly reset

If the BOD level is set to a value higher than VDDCORE and enabled by fuses, the part will be in constant reset.

Fix/Workaround

Apply an external voltage on VDDCORE that is higher than the BOD level and is lower than VDDCORE max and disable the BOD.

13. When the main clock is RCSYS, TIMER_CLOCK5 is equal to PBA clock

When the main clock is generated from RCSYS, TIMER_CLOCK5 is equal to PBA Clock and not PBA Clock / 128.

Fix/Workaround

None.

14. Clock sources will not be stopped in STATIC sleep mode if the difference between CPU and PBx division factor is too high

If the division factor between the CPU/HSB and PBx frequencies is more than 4 when going to a sleep mode where the system RC oscillator is turned off, then high speed clock sources

will not be turned off. This will result in a significantly higher power consumption during the sleep mode.

Fix/Workaround

Before going to sleep modes where the system RC oscillator is stopped, make sure that the factor between the CPU/HSB and PBx frequencies is less than or equal to 4.

15. Increased Power Consumption in VDDIO in sleep modes

If the OSC0 is enabled in crystal mode when entering a sleep mode where the OSC0 is disabled, this will lead to an increased power consumption in VDDIO.

Fix/Workaround

Disable the OSC0 through the Power Manager (PM) before going to any sleep mode where the OSC0 is disabled, or pull down or up XIN0 and XOUT0 with 1Mohm resistor.

16. SSC

17. Additional delay on TD output

A delay from 2 to 3 system clock cycles is added to TD output when:

TCMR.START = Receive Start,

TCMR.STTDLY = more than ZERO,

RCMR.START = Start on falling edge / Start on Rising edge / Start on any edge,

RFMR.FSOS = None (input).

Fix/Workaround

None.

18. TF output is not correct

TF output is not correct (at least emitted one serial clock cycle later than expected) when:

TFMR.FSOS = Driven Low during data transfer/ Driven High during data transfer

TCMR.START = Receive start

RFMR.FSOS = None (Input)

RCMR.START = any on RF (edge/level)

Fix/Workaround

None.

19. Frame Synchro and Frame Synchro Data are delayed by one clock cycle

The frame synchro and the frame synchro data are delayed from 1 SSC_CLOCK when:

- Clock is CKDIV

- The START is selected on either a frame synchro edge or a level

- Frame synchro data is enabled

- Transmit clock is gated on output (through CKO field)

Fix/Workaround

Transmit or receive CLOCK must not be gated (by the mean of CKO field) when START condition is performed on a generated frame synchro.

20. USB

21. UPCFGn.INTFRQ is irrelevant for isochronous pipe

As a consequence, isochronous IN and OUT tokens are sent every 1 ms (Full Speed), or every 125µs (High Speed).

Fix/Workaround

For higher polling time, the software must freeze the pipe for the desired period in order to prevent any "extra" token.

- ADC

1. Sleep Mode activation needs additional A to D conversion

If the ADC sleep mode is activated when the ADC is idle the ADC will not enter sleep mode before after the next AD conversion.

Fix/Workaround

Activate the sleep mode in the mode register and then perform an AD conversion.

- PDCA

1. Wrong PDCA behavior when using two PDCA channels with the same PID

Wrong PDCA behavior when using two PDCA channels with the same PID.

Fix/Workaround

The same PID should not be assigned to more than one channel.

2. Transfer error will stall a transmit peripheral handshake interface

If a transfer error is encountered on a channel transmitting to a peripheral, the peripheral handshake of the active channel will stall and the PDCA will not do any more transfers on the affected peripheral handshake interface.

Fix/Workaround

Disable and then enable the peripheral after the transfer error.

3. TWI

4. The TWI RXRDY flag in SR register is not reset when a software reset is performed

The TWI RXRDY flag in SR register is not reset when a software reset is performed.

Fix/Workaround

After a Software Reset, the register TWI RHR must be read.

5. TWI in master mode will continue to read data

TWI in master mode will continue to read data on the line even if the shift register and the RHR register are full. This will generate an overrun error.

Fix/Workaround

To prevent this, read the RHR register as soon as a new RX data is ready.

6. TWI slave behaves improperly if master acknowledges the last transmitted data byte before a STOP condition

In I2C slave transmitter mode, if the master acknowledges the last data byte before a STOP condition (what the master is not supposed to do), the following TWI slave receiver mode frame may contain an inappropriate clock stretch. This clock stretch can only be stopped by resetting the TWI.

Fix/Workaround

If the TWI is used as a slave transmitter with a master that acknowledges the last data byte before a STOP condition, it is necessary to reset the TWI before entering slave receiver mode.



7. TC

8. **Channel chaining skips first pulse for upper channel**

When chaining two channels using the Block Mode Register, the first pulse of the clock between the channels is skipped.

Fix/Workaround

Configure the lower channel with RA = 0x1 and RC = 0x2 to produce a dummy clock cycle for the upper channel. After the dummy cycle has been generated, indicated by the SR.CPCS bit, reconfigure the RA and RC registers for the lower channel with the real values.

*- Processor and Architecture*1. **LDM instruction with PC in the register list and without ++ increments Rp**

For LDM with PC in the register list: the instruction behaves as if the ++ field is always set, ie the pointer is always updated. This happens even if the ++ field is cleared. Specifically, the increment of the pointer is done in parallel with the testing of R12.

Fix/Workaround

None.

2. **RETE instruction does not clear SREG[L] from interrupts**

The RETE instruction clears SREG[L] as expected from exceptions.

Fix/Workaround

When using the STCOND instruction, clear SREG[L] in the stacked value of SR before returning from interrupts with RETE.

3. **Privilege violation when using interrupts in application mode with protected system stack**

If the system stack is protected by the MPU and an interrupt occurs in application mode, an MPU DTLB exception will occur.

Fix/Workaround

Make a DTLB Protection (Write) exception handler which permits the interrupt request to be handled in privileged mode.

4. **USART**5. **ISO7816 info register US_NER cannot be read**

The NER register always returns zero.

Fix/Workaround

None.

6. **ISO7816 Mode T1: RX impossible after any TX**

RX impossible after any TX.

Fix/Workaround

SOFT_RESET on RX+ Config US_MR + Config_US_CR.

7. **The RTS output does not function correctly in hardware handshaking mode**

The RTS signal is not generated properly when the USART receives data in hardware handshaking mode. When the Peripheral DMA receive buffer becomes full, the RTS output should go high, but it will stay low.

Fix/Workaround

Do not use the hardware handshaking mode of the USART. If it is necessary to drive the RTS output high when the Peripheral DMA receive buffer becomes full, use the normal mode of the USART. Configure the Peripheral DMA Controller to signal an interrupt when

the receive buffer is full. In the interrupt handler code, write a one to the RTSDIS bit in the USART Control Register (CR). This will drive the RTS output high. After the next DMA transfer is started and a receive buffer is available, write a one to the RTSEN bit in the USART CR so that RTS will be driven low.

8. Corruption after receiving too many bits in SPI slave mode

If the USART is in SPI slave mode and receives too much data bits (ex: 9bits instead of 8 bits) by the SPI master, an error occurs. After that, the next reception may be corrupted even if the frame is correct and the USART has been disabled, reset by a soft reset and re-enabled.

Fix/Workaround

None.

9. USART slave synchronous mode external clock must be at least 9 times lower in frequency than CLK_USART

When the USART is operating in slave synchronous mode with an external clock, the frequency of the signal provided on CLK must be at least 9 times lower than CLK_USART.

Fix/Workaround

When the USART is operating in slave synchronous mode with an external clock, provide a signal on CLK that has a frequency at least 9 times lower than CLK_USART.

10. HMATRIX

11. In the PRAS and PRBS registers, the MxPR fields are only two bits

In the PRAS and PRBS registers, the MxPR fields are only two bits wide, instead of four bits. The unused bits are undefined when reading the registers.

Fix/Workaround

Mask undefined bits when reading PRAS and PRBS.

- DSP Operations

1. Hardware breakpoints may corrupt MAC results

Hardware breakpoints on MAC instructions may corrupt the destination register of the MAC instruction.

Fix/Workaround

Place breakpoints on earlier or later instructions.

31.1.2 Rev C

- PWM

1. **PWM channel interrupt enabling triggers an interrupt**
 When enabling a PWM channel that is configured with center aligned period (CALG=1), an interrupt is signalled.
Fix/Workaround
 When using center aligned mode, enable the channel and read the status before channel interrupt is enabled.
2. **PWN counter restarts at 0x0001**
 The PWM counter restarts at 0x0001 and not 0x0000 as specified. Because of this the first PWM period has one more clock cycle.
Fix/Workaround
 - The first period is 0x0000, 0x0001, ..., period.
 - Consecutive periods are 0x0001, 0x0002, ..., period.
3. **PWM update period to a 0 value does not work**
 It is impossible to update a period equal to 0 by the using the PWM update register (PWM_CUPD).
Fix/Workaround
 Do not update the PWM_CUPD register with a value equal to 0.
4. **SPI**
5. **SPI Slave / PDCA transfer: no TX UNDERRUN flag**
 There is no TX UNDERRUN flag available, therefore in SPI slave mode, there is no way to be informed of a character lost in transmission.
Fix/Workaround
 For PDCA transfer: none.
6. **SPI bad serial clock generation on 2nd chip_select when SCBR=1, CPOL=1, and NCPHA=0**
 When multiple chip selects (CS) are in use, if one of the baudrates equal 1 while one (CSRn.SCBR=1) of the others do not equal 1, and CSRn.CPOL=1 and CSRn.NCPHA=0, then an additional pulse will be generated on SCK.
Fix/Workaround
 When multiple CS are in use, if one of the baudrates equals 1, the others must also equal 1 if CSRn.CPOL=1 and CSRn.NCPHA=0.
7. **SPI Glitch on RXREADY flag in slave mode when enabling the SPI or during the first transfer**
 In slave mode, the SPI can generate a false RXREADY signal during enabling of the SPI or during the first transfer.
Fix/Workaround
 1. Set slave mode, set required CPOL/CPHA.
 2. Enable SPI.
 3. Set the polarity CPOL of the line in the opposite value of the required one.
 4. Set the polarity CPOL to the required one.
 5. Read the RXHOLDING register.
 Transfers can now begin and RXREADY will now behave as expected.

8. SPI disable does not work in SLAVE mode

SPI disable does not work in SLAVE mode.

Fix/Workaround

Read the last received data, then perform a software reset by writing a one to the Software Reset bit in the Control Register (CR.SWRST).

9. SPI data transfer hangs with CSR0.CSAAT==1 and MR.MODFDIS==0

When CSR0.CSAAT==1 and mode fault detection is enabled (MR.MODFDIS==0), the SPI module will not start a data transfer.

Fix/Workaround

Disable mode fault detection by writing a one to MR.MODFDIS.

10. Disabling SPI has no effect on the SR.TDRE bit

Disabling SPI has no effect on the SR.TDRE bit whereas the write data command is filtered when SPI is disabled. Writing to TDR when SPI is disabled will not clear SR.TDRE. If SPI is disabled during a PDCA transfer, the PDCA will continue to write data to TDR until its buffer is empty, and this data will be lost.

Fix/Workaround

Disable the PDCA, add two NOPs, and disable the SPI. To continue the transfer, enable the SPI and PDCA.

11. Power Manager**12. If the BOD level is higher than VDDCORE, the part is constantly reset**

If the BOD level is set to a value higher than VDDCORE and enabled by fuses, the part will be in constant reset.

Fix/Workaround

Apply an external voltage on VDDCORE that is higher than the BOD level and is lower than VDDCORE max and disable the BOD.

13. When the main clock is RCSYS, TIMER_CLOCK5 is equal to PBA clock

When the main clock is generated from RCSYS, TIMER_CLOCK5 is equal to PBA Clock and not PBA Clock / 128.

Fix/Workaround

None.

14. VDDCORE power supply input needs to be 1.95V

When used in dual power supply, VDDCORE needs to be 1.95V.

Fix/Workaround

When used in single power supply, VDDCORE needs to be connected to VDDOUT, which is configured on revision C at 1.95V (typ.).

15. Clock sources will not be stopped in STATIC sleep mode if the difference between CPU and PBx division factor is too high

If the division factor between the CPU/HSB and PBx frequencies is more than 4 when going to a sleep mode where the system RC oscillator is turned off, then high speed clock sources will not be turned off. This will result in a significantly higher power consumption during the sleep mode.

Fix/Workaround

Before going to sleep modes where the system RC oscillator is stopped, make sure that the factor between the CPU/HSB and PBx frequencies is less than or equal to 4.

16. Increased Power Consumption in VDDIO in sleep modes

If the OSC0 is enabled in crystal mode when entering a sleep mode where the OSC0 is disabled, this will lead to an increased power consumption in VDDIO.

Fix/Workaround

Disable the OSC0 through the Power Manager (PM) before going to any sleep mode where the OSC0 is disabled, or pull down or up XIN0 and XOUT0 with 1Mohm resistor.

17. SSC

18. Additional delay on TD output

A delay from 2 to 3 system clock cycles is added to TD output when:

TCMR.START = Receive Start,

TCMR.STTDLY = more than ZERO,

RCMR.START = Start on falling edge / Start on Rising edge / Start on any edge,

RFMR.FSOS = None (input).

Fix/Workaround

None.

19. TF output is not correct

TF output is not correct (at least emitted one serial clock cycle later than expected) when:

TFMR.FSOS = Driven Low during data transfer/ Driven High during data transfer

TCMR.START = Receive start

RFMR.FSOS = None (Input)

RCMR.START = any on RF (edge/level)

Fix/Workaround

None.

20. Frame Synchro and Frame Synchro Data are delayed by one clock cycle

The frame synchro and the frame synchro data are delayed from 1 SSC_CLOCK when:

- Clock is CKDIV

- The START is selected on either a frame synchro edge or a level

- Frame synchro data is enabled

- Transmit clock is gated on output (through CKO field)

Fix/Workaround

Transmit or receive CLOCK must not be gated (by the mean of CKO field) when START condition is performed on a generated frame synchro.

21. USB

22. UPCFGn.INTFRQ is irrelevant for isochronous pipe

As a consequence, isochronous IN and OUT tokens are sent every 1ms (Full Speed), or every 125uS (High Speed).

Fix/Workaround

For higher polling time, the software must freeze the pipe for the desired period in order to prevent any "extra" token.

- ADC

1. Sleep Mode activation needs additional A to D conversion

If the ADC sleep mode is activated when the ADC is idle the ADC will not enter sleep mode before after the next AD conversion.

Fix/Workaround

Activate the sleep mode in the mode register and then perform an AD conversion.

- PDCA

1. Wrong PDCA behavior when using two PDCA channels with the same PID

Wrong PDCA behavior when using two PDCA channels with the same PID.

Fix/Workaround

The same PID should not be assigned to more than one channel.

2. Transfer error will stall a transmit peripheral handshake interface

If a transfer error is encountered on a channel transmitting to a peripheral, the peripheral handshake of the active channel will stall and the PDCA will not do any more transfers on the affected peripheral handshake interface.

Fix/Workaround

Disable and then enable the peripheral after the transfer error.

3. TWI**4. The TWI RXRDY flag in SR register is not reset when a software reset is performed**

The TWI RXRDY flag in SR register is not reset when a software reset is performed.

Fix/Workaround

After a Software Reset, the register TWI RHR must be read.

5. TWI in master mode will continue to read data

TWI in master mode will continue to read data on the line even if the shift register and the RHR register are full. This will generate an overrun error.

Fix/Workaround

To prevent this, read the RHR register as soon as a new RX data is ready.

6. TWI slave behaves improperly if master acknowledges the last transmitted data byte before a STOP condition

In I2C slave transmitter mode, if the master acknowledges the last data byte before a STOP condition (what the master is not supposed to do), the following TWI slave receiver mode frame may contain an inappropriate clock stretch. This clock stretch can only be stopped by resetting the TWI.

Fix/Workaround

If the TWI is used as a slave transmitter with a master that acknowledges the last data byte before a STOP condition, it is necessary to reset the TWI before entering slave receiver mode.

7. TC**8. Channel chaining skips first pulse for upper channel**

When chaining two channels using the Block Mode Register, the first pulse of the clock between the channels is skipped.

Fix/Workaround

Configure the lower channel with RA = 0x1 and RC = 0x2 to produce a dummy clock cycle for the upper channel. After the dummy cycle has been generated, indicated by the SR.CPCS bit, reconfigure the RA and RC registers for the lower channel with the real values.

- Processor and Architecture

1. LDM instruction with PC in the register list and without ++ increments Rp

For LDM with PC in the register list: the instruction behaves as if the ++ field is always set, ie the pointer is always updated. This happens even if the ++ field is cleared. Specifically, the increment of the pointer is done in parallel with the testing of R12.

Fix/Workaround

None.

2. RETE instruction does not clear SREG[L] from interrupts

The RETE instruction clears SREG[L] as expected from exceptions.

Fix/Workaround

When using the STCOND instruction, clear SREG[L] in the stacked value of SR before returning from interrupts with RETE.

3. Privilege violation when using interrupts in application mode with protected system stack

If the system stack is protected by the MPU and an interrupt occurs in application mode, an MPU DTLB exception will occur.

Fix/Workaround

Make a DTLB Protection (Write) exception handler which permits the interrupt request to be handled in privileged mode.

4. Flash**5. Reset vector is 80000020h rather than 80000000h**

Reset vector is 80000020h rather than 80000000h.

Fix/Workaround

The flash program code must start at the address 80000020h. The flash memory range 80000000h-80000020h must be programmed with 00000000h.

- USART

1. ISO7816 info register US_NER cannot be read

The NER register always returns zero.

Fix/Workaround

None.

2. ISO7816 Mode T1: RX impossible after any TX

RX impossible after any TX.

Fix/Workaround

SOFT_RESET on RX+ Config US_MR + Config_US_CR.

3. The RTS output does not function correctly in hardware handshaking mode

The RTS signal is not generated properly when the USART receives data in hardware handshaking mode. When the Peripheral DMA receive buffer becomes full, the RTS output should go high, but it will stay low.

Fix/Workaround

Do not use the hardware handshaking mode of the USART. If it is necessary to drive the RTS output high when the Peripheral DMA receive buffer becomes full, use the normal mode of the USART. Configure the Peripheral DMA Controller to signal an interrupt when the receive buffer is full. In the interrupt handler code, write a one to the RTSDIS bit in the USART Control Register (CR). This will drive the RTS output high. After the next DMA trans-

fer is started and a receive buffer is available, write a one to the RTSEN bit in the USART CR so that RTS will be driven low.

4. Corruption after receiving too many bits in SPI slave mode

If the USART is in SPI slave mode and receives too much data bits (ex: 9bits instead of 8 bits) by the SPI master, an error occurs. After that, the next reception may be corrupted even if the frame is correct and the USART has been disabled, reset by a soft reset and re-enabled.

Fix/Workaround

None.

5. USART slave synchronous mode external clock must be at least 9 times lower in frequency than CLK_USART

When the USART is operating in slave synchronous mode with an external clock, the frequency of the signal provided on CLK must be at least 9 times lower than CLK_USART.

Fix/Workaround

When the USART is operating in slave synchronous mode with an external clock, provide a signal on CLK that has a frequency at least 9 times lower than CLK_USART.

6. HMATRIX

7. In the PRAS and PRBS registers, the MxPR fields are only two bits

In the PRAS and PRBS registers, the MxPR fields are only two bits wide, instead of four bits. The unused bits are undefined when reading the registers.

Fix/Workaround

Mask undefined bits when reading PRAS and PRBS.

- DSP Operations

1. Hardware breakpoints may corrupt MAC results

Hardware breakpoints on MAC instructions may corrupt the destination register of the MAC instruction.

Fix/Workaround

Place breakpoints on earlier or later instructions.

31.2 AT32UC3B0256, AT32UC3B0128, AT32UC3B064, AT32UC3B1256, AT32UC3B1128, AT32UC3B164

All industrial parts labelled with -UES (for engineering samples) are revision B parts.

31.2.1 Rev I, J, K

- PWM

- 1. PWM channel interrupt enabling triggers an interrupt**
 When enabling a PWM channel that is configured with center aligned period (CALG=1), an interrupt is signalled.
Fix/Workaround
 When using center aligned mode, enable the channel and read the status before channel interrupt is enabled.
- 2. PWN counter restarts at 0x0001**
 The PWM counter restarts at 0x0001 and not 0x0000 as specified. Because of this the first PWM period has one more clock cycle.
Fix/Workaround
 - The first period is 0x0000, 0x0001, ..., period.
 - Consecutive periods are 0x0001, 0x0002, ..., period.
- 3. PWM update period to a 0 value does not work**
 It is impossible to update a period equal to 0 by the using the PWM update register (PWM_CUPD).
Fix/Workaround
 Do not update the PWM_CUPD register with a value equal to 0.
- 4. SPI**
- 5. SPI Slave / PDCA transfer: no TX UNDERRUN flag**
 There is no TX UNDERRUN flag available, therefore in SPI slave mode, there is no way to be informed of a character lost in transmission.
Fix/Workaround
 For PDCA transfer: none.
- 6. SPI bad serial clock generation on 2nd chip_select when SCBR=1, CPOL=1, and NCPHA=0**
 When multiple chip selects (CS) are in use, if one of the baudrates equal 1 while one (CSRn.SCBR=1) of the others do not equal 1, and CSRn.CPOL=1 and CSRn.NCPHA=0, then an additional pulse will be generated on SCK.
Fix/Workaround
 When multiple CS are in use, if one of the baudrates equals 1, the others must also equal 1 if CSRn.CPOL=1 and CSRn.NCPHA=0.
- 7. SPI Glitch on RXREADY flag in slave mode when enabling the SPI or during the first transfer**
 In slave mode, the SPI can generate a false RXREADY signal during enabling of the SPI or during the first transfer.
Fix/Workaround
 1. Set slave mode, set required CPOL/CPHA.
 2. Enable SPI.

3. Set the polarity CPOL of the line in the opposite value of the required one.
 4. Set the polarity CPOL to the required one.
 5. Read the RXHOLDING register.
- Transfers can now begin and RXREADY will now behave as expected.

8. SPI disable does not work in SLAVE mode

SPI disable does not work in SLAVE mode.

Fix/Workaround

Read the last received data, then perform a software reset by writing a one to the Software Reset bit in the Control Register (CR.SWRST).

9. SPI data transfer hangs with CSR0.CSAAT==1 and MR.MODFDIS==0

When CSR0.CSAAT==1 and mode fault detection is enabled (MR.MODFDIS==0), the SPI module will not start a data transfer.

Fix/Workaround

Disable mode fault detection by writing a one to MR.MODFDIS.

10. Disabling SPI has no effect on the SR.TDRE bit

Disabling SPI has no effect on the SR.TDRE bit whereas the write data command is filtered when SPI is disabled. Writing to TDR when SPI is disabled will not clear SR.TDRE. If SPI is disabled during a PDCA transfer, the PDCA will continue to write data to TDR until its buffer is empty, and this data will be lost.

Fix/Workaround

Disable the PDCA, add two NOPs, and disable the SPI. To continue the transfer, enable the SPI and PDCA.

11. Power Manager

12. If the BOD level is higher than VDDCORE, the part is constantly reset

If the BOD level is set to a value higher than VDDCORE and enabled by fuses, the part will be in constant reset.

Fix/Workaround

Apply an external voltage on VDDCORE that is higher than the BOD level and is lower than VDDCORE max and disable the BOD.

1. When the main clock is RCSYS, TIMER_CLOCK5 is equal to PBA clock

When the main clock is generated from RCSYS, TIMER_CLOCK5 is equal to PBA Clock and not PBA Clock / 128.

Fix/Workaround

None.

13. Clock sources will not be stopped in STATIC sleep mode if the difference between CPU and PBx division factor is too high

If the division factor between the CPU/HSB and PBx frequencies is more than 4 when going to a sleep mode where the system RC oscillator is turned off, then high speed clock sources will not be turned off. This will result in a significantly higher power consumption during the sleep mode.

Fix/Workaround

Before going to sleep modes where the system RC oscillator is stopped, make sure that the factor between the CPU/HSB and PBx frequencies is less than or equal to 4.

14. SSC

15. Additional delay on TD output

A delay from 2 to 3 system clock cycles is added to TD output when:

TCMR.START = Receive Start,

TCMR.STTDLY = more than ZERO,

RCMR.START = Start on falling edge / Start on Rising edge / Start on any edge,

RFMR.FSOS = None (input).

Fix/Workaround

None.

16. TF output is not correct

TF output is not correct (at least emitted one serial clock cycle later than expected) when:

TFMR.FSOS = Driven Low during data transfer/ Driven High during data transfer

TCMR.START = Receive start

RFMR.FSOS = None (Input)

RCMR.START = any on RF (edge/level)

Fix/Workaround

None.

17. Frame Synchro and Frame Synchro Data are delayed by one clock cycle

The frame synchro and the frame synchro data are delayed from 1 SSC_CLOCK when:

- Clock is CKDIV

- The START is selected on either a frame synchro edge or a level

- Frame synchro data is enabled

- Transmit clock is gated on output (through CKO field)

Fix/Workaround

Transmit or receive CLOCK must not be gated (by the mean of CKO field) when START condition is performed on a generated frame synchro.

18. USB

19. UPCFGn.INTFRQ is irrelevant for isochronous pipe

As a consequence, isochronous IN and OUT tokens are sent every 1ms (Full Speed), or every 125uS (High Speed).

Fix/Workaround

For higher polling time, the software must freeze the pipe for the desired period in order to prevent any "extra" token.

- ADC

1. Sleep Mode activation needs additional A to D conversion

If the ADC sleep mode is activated when the ADC is idle the ADC will not enter sleep mode before after the next AD conversion.

Fix/Workaround

Activate the sleep mode in the mode register and then perform an AD conversion.

- PDCA

1. Wrong PDCA behavior when using two PDCA channels with the same PID

Wrong PDCA behavior when using two PDCA channels with the same PID.

Fix/Workaround

The same PID should not be assigned to more than one channel.

2. **Transfer error will stall a transmit peripheral handshake interface**
 If a transfer error is encountered on a channel transmitting to a peripheral, the peripheral handshake of the active channel will stall and the PDCA will not do any more transfers on the affected peripheral handshake interface.
Fix/Workaround
 Disable and then enable the peripheral after the transfer error.
 3. **TWI**
 4. **The TWI RXRDY flag in SR register is not reset when a software reset is performed**
 The TWI RXRDY flag in SR register is not reset when a software reset is performed.
Fix/Workaround
 After a Software Reset, the register TWI RHR must be read.
 5. **TWI in master mode will continue to read data**
 TWI in master mode will continue to read data on the line even if the shift register and the RHR register are full. This will generate an overrun error.
Fix/Workaround
 To prevent this, read the RHR register as soon as a new RX data is ready.
 6. **TWI slave behaves improperly if master acknowledges the last transmitted data byte before a STOP condition**
 In I2C slave transmitter mode, if the master acknowledges the last data byte before a STOP condition (what the master is not supposed to do), the following TWI slave receiver mode frame may contain an inappropriate clock stretch. This clock stretch can only be stopped by resetting the TWI.
Fix/Workaround
 If the TWI is used as a slave transmitter with a master that acknowledges the last data byte before a STOP condition, it is necessary to reset the TWI before entering slave receiver mode.
 7. **TC**
 8. **Channel chaining skips first pulse for upper channel**
 When chaining two channels using the Block Mode Register, the first pulse of the clock between the channels is skipped.
Fix/Workaround
 Configure the lower channel with RA = 0x1 and RC = 0x2 to produce a dummy clock cycle for the upper channel. After the dummy cycle has been generated, indicated by the SR.CPCS bit, reconfigure the RA and RC registers for the lower channel with the real values.
- OCD
1. **The auxiliary trace does not work for CPU/HSB speed higher than 50MHz**
 The auxiliary trace does not work for CPU/HSB speed higher than 50MHz.
Fix/Workaround
 Do not use the auxiliary trace for CPU/HSB speed higher than 50MHz.

- Processor and Architecture

1. **LDM instruction with PC in the register list and without ++ increments Rp**
 For LDM with PC in the register list: the instruction behaves as if the ++ field is always set, ie the pointer is always updated. This happens even if the ++ field is cleared. Specifically, the increment of the pointer is done in parallel with the testing of R12.
Fix/Workaround
 None.
2. **RETE instruction does not clear SREG[L] from interrupts**
 The RETE instruction clears SREG[L] as expected from exceptions.
Fix/Workaround
 When using the STCOND instruction, clear SREG[L] in the stacked value of SR before returning from interrupts with RETE.
3. **Privilege violation when using interrupts in application mode with protected system stack**
 If the system stack is protected by the MPU and an interrupt occurs in application mode, an MPU DTLB exception will occur.
Fix/Workaround
 Make a DTLB Protection (Write) exception handler which permits the interrupt request to be handled in privileged mode.
4. **USART**
5. **ISO7816 info register US_NER cannot be read**
 The NER register always returns zero.
Fix/Workaround
 None.
6. **ISO7816 Mode T1: RX impossible after any TX**
 RX impossible after any TX.
Fix/Workaround
 SOFT_RESET on RX+ Config US_MR + Config_US_CR.
7. **The RTS output does not function correctly in hardware handshaking mode**
 The RTS signal is not generated properly when the USART receives data in hardware handshaking mode. When the Peripheral DMA receive buffer becomes full, the RTS output should go high, but it will stay low.
Fix/Workaround
 Do not use the hardware handshaking mode of the USART. If it is necessary to drive the RTS output high when the Peripheral DMA receive buffer becomes full, use the normal mode of the USART. Configure the Peripheral DMA Controller to signal an interrupt when the receive buffer is full. In the interrupt handler code, write a one to the RTSDIS bit in the USART Control Register (CR). This will drive the RTS output high. After the next DMA transfer is started and a receive buffer is available, write a one to the RTSEN bit in the USART CR so that RTS will be driven low.
8. **Corruption after receiving too many bits in SPI slave mode**
 If the USART is in SPI slave mode and receives too much data bits (ex: 9bits instead of 8 bits) by the SPI master, an error occurs. After that, the next reception may be corrupted

even if the frame is correct and the USART has been disabled, reset by a soft reset and re-enabled.

Fix/Workaround

None.

9. USART slave synchronous mode external clock must be at least 9 times lower in frequency than CLK_USART

When the USART is operating in slave synchronous mode with an external clock, the frequency of the signal provided on CLK must be at least 9 times lower than CLK_USART.

Fix/Workaround

When the USART is operating in slave synchronous mode with an external clock, provide a signal on CLK that has a frequency at least 9 times lower than CLK_USART.

10. HMATRIX

11. In the PRAS and PRBS registers, the MxPR fields are only two bits

In the PRAS and PRBS registers, the MxPR fields are only two bits wide, instead of four bits. The unused bits are undefined when reading the registers.

Fix/Workaround

Mask undefined bits when reading PRAS and PRBS.

- FLASHC

1. Reading from on-chip flash may fail after a flash fuse write operation (FLASHC LP, UP, WGPB, EGPB, SSB, PGPFB, EAGPF commands).

After a flash fuse write operation (FLASHC LP, UP, WGPB, EGPB, SSB, PGPFB, EAGPF commands), the following flash read access may return corrupted data. This erratum does not affect write operations to regular flash memory.

Fix/Workaround

The flash fuse write operation (FLASHC LP, UP, WGPB, EGPB, SSB, PGPFB, EAGPF commands) must be issued from internal RAM. After the write operation, perform a dummy flash page write operation (FLASHC WP). Content and location of this page is not important and filling the write buffer with all one (FFh) will leave the current flash content unchanged. It is then safe to read and fetch code from the flash.

- DSP Operations

1. Hardware breakpoints may corrupt MAC results

Hardware breakpoints on MAC instructions may corrupt the destination register of the MAC instruction.

Fix/Workaround

Place breakpoints on earlier or later instructions.

31.2.2 Rev. G

- PWM

1. **PWM channel interrupt enabling triggers an interrupt**
 When enabling a PWM channel that is configured with center aligned period (CALG=1), an interrupt is signalled.
Fix/Workaround
 When using center aligned mode, enable the channel and read the status before channel interrupt is enabled.
2. **PWN counter restarts at 0x0001**
 The PWM counter restarts at 0x0001 and not 0x0000 as specified. Because of this the first PWM period has one more clock cycle.
Fix/Workaround
 - The first period is 0x0000, 0x0001, ..., period.
 - Consecutive periods are 0x0001, 0x0002, ..., period.
3. **PWM update period to a 0 value does not work**
 It is impossible to update a period equal to 0 by the using the PWM update register (PWM_CUPD).
Fix/Workaround
 Do not update the PWM_CUPD register with a value equal to 0.
4. **SPI**
5. **SPI Slave / PDCA transfer: no TX UNDERRUN flag**
 There is no TX UNDERRUN flag available, therefore in SPI slave mode, there is no way to be informed of a character lost in transmission.
Fix/Workaround
 For PDCA transfer: none.
6. **SPI bad serial clock generation on 2nd chip_select when SCBR=1, CPOL=1, and NCPHA=0**
 When multiple chip selects (CS) are in use, if one of the baudrates equal 1 while one (CSRn.SCBR=1) of the others do not equal 1, and CSRn.CPOL=1 and CSRn.NCPHA=0, then an additional pulse will be generated on SCK.
Fix/Workaround
 When multiple CS are in use, if one of the baudrates equals 1, the others must also equal 1 if CSRn.CPOL=1 and CSRn.NCPHA=0.
7. **SPI Glitch on RXREADY flag in slave mode when enabling the SPI or during the first transfer**
 In slave mode, the SPI can generate a false RXREADY signal during enabling of the SPI or during the first transfer.
Fix/Workaround
 1. Set slave mode, set required CPOL/CPHA.
 2. Enable SPI.
 3. Set the polarity CPOL of the line in the opposite value of the required one.
 4. Set the polarity CPOL to the required one.
 5. Read the RXHOLDING register.
 Transfers can now begin and RXREADY will now behave as expected.

8. SPI disable does not work in SLAVE mode

SPI disable does not work in SLAVE mode.

Fix/Workaround

Read the last received data, then perform a software reset by writing a one to the Software Reset bit in the Control Register (CR.SWRST).

9. SPI data transfer hangs with CSR0.CSAAT==1 and MR.MODFDIS==0

When CSR0.CSAAT==1 and mode fault detection is enabled (MR.MODFDIS==0), the SPI module will not start a data transfer.

Fix/Workaround

Disable mode fault detection by writing a one to MR.MODFDIS.

10. Disabling SPI has no effect on the SR.TDRE bit

Disabling SPI has no effect on the SR.TDRE bit whereas the write data command is filtered when SPI is disabled. Writing to TDR when SPI is disabled will not clear SR.TDRE. If SPI is disabled during a PDCA transfer, the PDCA will continue to write data to TDR until its buffer is empty, and this data will be lost.

Fix/Workaround

Disable the PDCA, add two NOPs, and disable the SPI. To continue the transfer, enable the SPI and PDCA.

11. Power Manager**12. If the BOD level is higher than VDDCORE, the part is constantly reset**

If the BOD level is set to a value higher than VDDCORE and enabled by fuses, the part will be in constant reset.

Fix/Workaround

Apply an external voltage on VDDCORE that is higher than the BOD level and is lower than VDDCORE max and disable the BOD.

2. When the main clock is RCSYS, TIMER_CLOCK5 is equal to PBA clock

When the main clock is generated from RCSYS, TIMER_CLOCK5 is equal to PBA Clock and not PBA Clock / 128.

Fix/Workaround

None.

13. Clock sources will not be stopped in STATIC sleep mode if the difference between CPU and PBx division factor is too high

If the division factor between the CPU/HSB and PBx frequencies is more than 4 when going to a sleep mode where the system RC oscillator is turned off, then high speed clock sources will not be turned off. This will result in a significantly higher power consumption during the sleep mode.

Fix/Workaround

Before going to sleep modes where the system RC oscillator is stopped, make sure that the factor between the CPU/HSB and PBx frequencies is less than or equal to 4.

14. Increased Power Consumption in VDDIO in sleep modes

If the OSC0 is enabled in crystal mode when entering a sleep mode where the OSC0 is disabled, this will lead to an increased power consumption in VDDIO.

Fix/Workaround

Disable the OSC0 through the System Control Interface (SCIF) before going to any sleep mode where the OSC0 is disabled, or pull down or up XIN0 and XOUT0 with 1 Mohm resistor.

15. SSC

16. Additional delay on TD output

A delay from 2 to 3 system clock cycles is added to TD output when:

TCMR.START = Receive Start,

TCMR.STTDLY = more than ZERO,

RCMR.START = Start on falling edge / Start on Rising edge / Start on any edge,

RFMR.FSOS = None (input).

Fix/Workaround

None.

17. TF output is not correct

TF output is not correct (at least emitted one serial clock cycle later than expected) when:

TFMR.FSOS = Driven Low during data transfer/ Driven High during data transfer

TCMR.START = Receive start

RFMR.FSOS = None (Input)

RCMR.START = any on RF (edge/level)

Fix/Workaround

None.

18. Frame Synchro and Frame Synchro Data are delayed by one clock cycle

The frame synchro and the frame synchro data are delayed from 1 SSC_CLOCK when:

- Clock is CKDIV

- The START is selected on either a frame synchro edge or a level

- Frame synchro data is enabled

- Transmit clock is gated on output (through CKO field)

Fix/Workaround

Transmit or receive CLOCK must not be gated (by the mean of CKO field) when START condition is performed on a generated frame synchro.

19. USB

20. UPCFGn.INTFRQ is irrelevant for isochronous pipe

As a consequence, isochronous IN and OUT tokens are sent every 1ms (Full Speed), or every 125uS (High Speed).

Fix/Workaround

For higher polling time, the software must freeze the pipe for the desired period in order to prevent any "extra" token.

- ADC

1. Sleep Mode activation needs additional A to D conversion

If the ADC sleep mode is activated when the ADC is idle the ADC will not enter sleep mode before after the next AD conversion.

Fix/Workaround

Activate the sleep mode in the mode register and then perform an AD conversion.

- PDCA

1. Wrong PDCA behavior when using two PDCA channels with the same PID

Wrong PDCA behavior when using two PDCA channels with the same PID.

Fix/Workaround

The same PID should not be assigned to more than one channel.

2. Transfer error will stall a transmit peripheral handshake interface

If a transfer error is encountered on a channel transmitting to a peripheral, the peripheral handshake of the active channel will stall and the PDCA will not do any more transfers on the affected peripheral handshake interface.

Fix/Workaround

Disable and then enable the peripheral after the transfer error.

3. TWI**4. The TWI RXRDY flag in SR register is not reset when a software reset is performed**

The TWI RXRDY flag in SR register is not reset when a software reset is performed.

Fix/Workaround

After a Software Reset, the register TWI RHR must be read.

5. TWI in master mode will continue to read data

TWI in master mode will continue to read data on the line even if the shift register and the RHR register are full. This will generate an overrun error.

Fix/Workaround

To prevent this, read the RHR register as soon as a new RX data is ready.

6. TWI slave behaves improperly if master acknowledges the last transmitted data byte before a STOP condition

In I2C slave transmitter mode, if the master acknowledges the last data byte before a STOP condition (what the master is not supposed to do), the following TWI slave receiver mode frame may contain an inappropriate clock stretch. This clock stretch can only be stopped by resetting the TWI.

Fix/Workaround

If the TWI is used as a slave transmitter with a master that acknowledges the last data byte before a STOP condition, it is necessary to reset the TWI before entering slave receiver mode.

7. GPIO**8. PA29 (TWI SDA) and PA30 (TWI SCL) GPIO VIH (input high voltage) is 3.6V max instead of 5V tolerant**

The following GPIOs are not 5V tolerant: PA29 and PA30.

Fix/Workaround

None.

- TC

1. Channel chaining skips first pulse for upper channel

When chaining two channels using the Block Mode Register, the first pulse of the clock between the channels is skipped.

Fix/Workaround

Configure the lower channel with RA = 0x1 and RC = 0x2 to produce a dummy clock cycle for the upper channel. After the dummy cycle has been generated, indicated by the SR.CPCS bit, reconfigure the RA and RC registers for the lower channel with the real values.

- *OCD***1. The auxiliary trace does not work for CPU/HSB speed higher than 50MHz**

The auxiliary trace does not work for CPU/HSB speed higher than 50MHz.

Fix/Workaround

Do not use the auxiliary trace for CPU/HSB speed higher than 50MHz.

- *Processor and Architecture***1. LDM instruction with PC in the register list and without ++ increments Rp**

For LDM with PC in the register list: the instruction behaves as if the ++ field is always set, ie the pointer is always updated. This happens even if the ++ field is cleared. Specifically, the increment of the pointer is done in parallel with the testing of R12.

Fix/Workaround

None.

2. RETE instruction does not clear SREG[L] from interrupts

The RETE instruction clears SREG[L] as expected from exceptions.

Fix/Workaround

When using the STCOND instruction, clear SREG[L] in the stacked value of SR before returning from interrupts with RETE.

3. RETS behaves incorrectly when MPU is enabled

RETS behaves incorrectly when MPU is enabled and MPU is configured so that system stack is not readable in unprivileged mode.

Fix/Workaround

Make system stack readable in unprivileged mode, or return from supervisor mode using rete instead of rets. This requires:

1. Changing the mode bits from 001 to 110 before issuing the instruction. Updating the mode bits to the desired value must be done using a single mtsr instruction so it is done atomically. Even if this step is generally described as not safe in the UC technical reference manual, it is safe in this very specific case.
2. Execute the RETE instruction.

4. Privilege violation when using interrupts in application mode with protected system stack

If the system stack is protected by the MPU and an interrupt occurs in application mode, an MPU DTLB exception will occur.

Fix/Workaround

Make a DTLB Protection (Write) exception handler which permits the interrupt request to be handled in privileged mode.

5. USART**6. ISO7816 info register US_NER cannot be read**

The NER register always returns zero.

Fix/Workaround

None.

7. ISO7816 Mode T1: RX impossible after any TX

RX impossible after any TX.

Fix/Workaround

SOFT_RESET on RX+ Config US_MR + Config_US_CR.

8. The RTS output does not function correctly in hardware handshaking mode

The RTS signal is not generated properly when the USART receives data in hardware handshaking mode. When the Peripheral DMA receive buffer becomes full, the RTS output should go high, but it will stay low.

Fix/Workaround

Do not use the hardware handshaking mode of the USART. If it is necessary to drive the RTS output high when the Peripheral DMA receive buffer becomes full, use the normal mode of the USART. Configure the Peripheral DMA Controller to signal an interrupt when the receive buffer is full. In the interrupt handler code, write a one to the RTSDIS bit in the USART Control Register (CR). This will drive the RTS output high. After the next DMA transfer is started and a receive buffer is available, write a one to the RTSEN bit in the USART CR so that RTS will be driven low.

9. Corruption after receiving too many bits in SPI slave mode

If the USART is in SPI slave mode and receives too much data bits (ex: 9bits instead of 8 bits) by the SPI master, an error occurs. After that, the next reception may be corrupted even if the frame is correct and the USART has been disabled, reset by a soft reset and re-enabled.

Fix/Workaround

None.

10. USART slave synchronous mode external clock must be at least 9 times lower in frequency than CLK_USART

When the USART is operating in slave synchronous mode with an external clock, the frequency of the signal provided on CLK must be at least 9 times lower than CLK_USART.

Fix/Workaround

When the USART is operating in slave synchronous mode with an external clock, provide a signal on CLK that has a frequency at least 9 times lower than CLK_USART.

11. HMATRIX**12. In the PRAS and PRBS registers, the MxPR fields are only two bits**

In the PRAS and PRBS registers, the MxPR fields are only two bits wide, instead of four bits. The unused bits are undefined when reading the registers.

Fix/Workaround

Mask undefined bits when reading PRAS and PRBS.

- FLASHC**1. Reading from on-chip flash may fail after a flash fuse write operation (FLASHC LP, UP, WGPB, EGPB, SSB, PGPFB, EAGPF commands).**

After a flash fuse write operation (FLASHC LP, UP, WGPB, EGPB, SSB, PGPFB, EAGPF commands), the following flash read access may return corrupted data. This erratum does not affect write operations to regular flash memory.

Fix/Workaround

The flash fuse write operation (FLASHC LP, UP, WGPB, EGPB, SSB, PGPFB, EAGPF commands) must be issued from internal RAM. After the write operation, perform a dummy flash page write operation (FLASHC WP). Content and location of this page is not important and filling the write buffer with all one (FFh) will leave the current flash content unchanged. It is then safe to read and fetch code from the flash.

- *DSP Operations*

1. Hardware breakpoints may corrupt MAC results

Hardware breakpoints on MAC instructions may corrupt the destination register of the MAC instruction.

Fix/Workaround

Place breakpoints on earlier or later instructions.

31.2.3 Rev. F

- PWM

1. **PWM channel interrupt enabling triggers an interrupt**
When enabling a PWM channel that is configured with center aligned period (CALG=1), an interrupt is signalled.
Fix/Workaround
When using center aligned mode, enable the channel and read the status before channel interrupt is enabled.
2. **PWN counter restarts at 0x0001**
The PWM counter restarts at 0x0001 and not 0x0000 as specified. Because of this the first PWM period has one more clock cycle.
Fix/Workaround
 - The first period is 0x0000, 0x0001, ..., period.
 - Consecutive periods are 0x0001, 0x0002, ..., period.
3. **PWM update period to a 0 value does not work**
It is impossible to update a period equal to 0 by the using the PWM update register (PWM_CUPD).
Fix/Workaround
Do not update the PWM_CUPD register with a value equal to 0.
4. **SPI**
5. **SPI Slave / PDCA transfer: no TX UNDERRUN flag**
There is no TX UNDERRUN flag available, therefore in SPI slave mode, there is no way to be informed of a character lost in transmission.
Fix/Workaround
For PDCA transfer: none.
6. **SPI bad serial clock generation on 2nd chip_select when SCBR=1, CPOL=1, and NCPHA=0**
When multiple chip selects (CS) are in use, if one of the baudrates equal 1 while one (CSRn.SCBR=1) of the others do not equal 1, and CSRn.CPOL=1 and CSRn.NCPHA=0, then an additional pulse will be generated on SCK.
Fix/Workaround
When multiple CS are in use, if one of the baudrates equals 1, the others must also equal 1 if CSRn.CPOL=1 and CSRn.NCPHA=0.
7. **SPI Glitch on RXREADY flag in slave mode when enabling the SPI or during the first transfer**
In slave mode, the SPI can generate a false RXREADY signal during enabling of the SPI or during the first transfer.
Fix/Workaround
 1. Set slave mode, set required CPOL/CPHA.
 2. Enable SPI.
 3. Set the polarity CPOL of the line in the opposite value of the required one.
 4. Set the polarity CPOL to the required one.
 5. Read the RXHOLDING register.

Transfers can now begin and RXREADY will now behave as expected.

8. SPI disable does not work in SLAVE mode

SPI disable does not work in SLAVE mode.

Fix/Workaround

Read the last received data, then perform a software reset by writing a one to the Software Reset bit in the Control Register (CR.SWRST).

9. SPI data transfer hangs with CSR0.CSAAT==1 and MR.MODFDIS==0

When CSR0.CSAAT==1 and mode fault detection is enabled (MR.MODFDIS==0), the SPI module will not start a data transfer.

Fix/Workaround

Disable mode fault detection by writing a one to MR.MODFDIS.

10. Disabling SPI has no effect on the SR.TDRE bit

Disabling SPI has no effect on the SR.TDRE bit whereas the write data command is filtered when SPI is disabled. Writing to TDR when SPI is disabled will not clear SR.TDRE. If SPI is disabled during a PDCA transfer, the PDCA will continue to write data to TDR until its buffer is empty, and this data will be lost.

Fix/Workaround

Disable the PDCA, add two NOPs, and disable the SPI. To continue the transfer, enable the SPI and PDCA.

11. Power Manager**12. If the BOD level is higher than VDDCORE, the part is constantly reset**

If the BOD level is set to a value higher than VDDCORE and enabled by fuses, the part will be in constant reset.

Fix/Workaround

Apply an external voltage on VDDCORE that is higher than the BOD level and is lower than VDDCORE max and disable the BOD.

3. When the main clock is RCSYS, TIMER_CLOCK5 is equal to PBA clock

When the main clock is generated from RCSYS, TIMER_CLOCK5 is equal to PBA Clock and not PBA Clock / 128.

Fix/Workaround

None.

13. Clock sources will not be stopped in STATIC sleep mode if the difference between CPU and PBx division factor is too high

If the division factor between the CPU/HSB and PBx frequencies is more than 4 when going to a sleep mode where the system RC oscillator is turned off, then high speed clock sources will not be turned off. This will result in a significantly higher power consumption during the sleep mode.

Fix/Workaround

Before going to sleep modes where the system RC oscillator is stopped, make sure that the factor between the CPU/HSB and PBx frequencies is less than or equal to 4.

14. Increased Power Consumption in VDDIO in sleep modes

If the OSC0 is enabled in crystal mode when entering a sleep mode where the OSC0 is disabled, this will lead to an increased power consumption in VDDIO.

Fix/Workaround

Disable the OSC0 through the System Control Interface (SCIF) before going to any sleep mode where the OSC0 is disabled, or pull down or up XIN0 and XOUT0 with 1 Mohm resistor.

15. SSC**16. Additional delay on TD output**

A delay from 2 to 3 system clock cycles is added to TD output when:

TCMR.START = Receive Start,

TCMR.STTDLY = more than ZERO,

RCMR.START = Start on falling edge / Start on Rising edge / Start on any edge,

RFMR.FSOS = None (input).

Fix/Workaround

None.

17. TF output is not correct

TF output is not correct (at least emitted one serial clock cycle later than expected) when:

TFMR.FSOS = Driven Low during data transfer/ Driven High during data transfer

TCMR.START = Receive start

RFMR.FSOS = None (Input)

RCMR.START = any on RF (edge/level)

Fix/Workaround

None.

18. Frame Synchro and Frame Synchro Data are delayed by one clock cycle

The frame synchro and the frame synchro data are delayed from 1 SSC_CLOCK when:

- Clock is CKDIV

- The START is selected on either a frame synchro edge or a level

- Frame synchro data is enabled

- Transmit clock is gated on output (through CKO field)

Fix/Workaround

Transmit or receive CLOCK must not be gated (by the mean of CKO field) when START condition is performed on a generated frame synchro.

19. USB**20. UPCFGn.INTFRQ is irrelevant for isochronous pipe**

As a consequence, isochronous IN and OUT tokens are sent every 1ms (Full Speed), or every 125µs (High Speed).

Fix/Workaround

For higher polling time, the software must freeze the pipe for the desired period in order to prevent any "extra" token.

- ADC

1. Sleep Mode activation needs additional A to D conversion

If the ADC sleep mode is activated when the ADC is idle the ADC will not enter sleep mode before after the next AD conversion.

Fix/Workaround

Activate the sleep mode in the mode register and then perform an AD conversion.

- PDCA

1. Wrong PDCA behavior when using two PDCA channels with the same PID

Wrong PDCA behavior when using two PDCA channels with the same PID.

Fix/Workaround

The same PID should not be assigned to more than one channel.

- 2. Transfer error will stall a transmit peripheral handshake interface**

If a transfer error is encountered on a channel transmitting to a peripheral, the peripheral handshake of the active channel will stall and the PDCA will not do any more transfers on the affected peripheral handshake interface.

Fix/Workaround
Disable and then enable the peripheral after the transfer error.
- 3. TWI**
- 4. The TWI RXRDY flag in SR register is not reset when a software reset is performed**

The TWI RXRDY flag in SR register is not reset when a software reset is performed.

Fix/Workaround
After a Software Reset, the register TWI RHR must be read.
- 5. TWI in master mode will continue to read data**

TWI in master mode will continue to read data on the line even if the shift register and the RHR register are full. This will generate an overrun error.

Fix/Workaround
To prevent this, read the RHR register as soon as a new RX data is ready.
- 6. TWI slave behaves improperly if master acknowledges the last transmitted data byte before a STOP condition**

In I2C slave transmitter mode, if the master acknowledges the last data byte before a STOP condition (what the master is not supposed to do), the following TWI slave receiver mode frame may contain an inappropriate clock stretch. This clock stretch can only be stopped by resetting the TWI.

Fix/Workaround
If the TWI is used as a slave transmitter with a master that acknowledges the last data byte before a STOP condition, it is necessary to reset the TWI before entering slave receiver mode.
- 7. GPIO**
- 8. PA29 (TWI SDA) and PA30 (TWI SCL) GPIO VIH (input high voltage) is 3.6V max instead of 5V tolerant**

The following GPIOs are not 5V tolerant: PA29 and PA30.

Fix/Workaround
None.
- 9. Some GPIO VIH (input high voltage) are 3.6V max instead of 5V tolerant**

Only 11 GPIOs remain 5V tolerant (VIHmax=5V): PB01, PB02, PB03, PB10, PB19, PB20, PB21, PB22, PB23, PB27, PB28.

Fix/Workaround
None.
- 10. TC**
- 11. Channel chaining skips first pulse for upper channel**

When chaining two channels using the Block Mode Register, the first pulse of the clock between the channels is skipped.

Fix/Workaround
Configure the lower channel with RA = 0x1 and RC = 0x2 to produce a dummy clock cycle for the upper channel. After the dummy cycle has been generated, indicated by the

SR.CPCS bit, reconfigure the RA and RC registers for the lower channel with the real values.

- *OCD*

1. The auxiliary trace does not work for CPU/HSB speed higher than 50MHz

The auxiliary trace does not work for CPU/HSB speed higher than 50MHz.

Fix/Workaround

Do not use the auxiliary trace for CPU/HSB speed higher than 50MHz.

- *Processor and Architecture*

1. LDM instruction with PC in the register list and without ++ increments Rp

For LDM with PC in the register list: the instruction behaves as if the ++ field is always set, ie the pointer is always updated. This happens even if the ++ field is cleared. Specifically, the increment of the pointer is done in parallel with the testing of R12.

Fix/Workaround

None.

2. RETE instruction does not clear SREG[L] from interrupts

The RETE instruction clears SREG[L] as expected from exceptions.

Fix/Workaround

When using the STCOND instruction, clear SREG[L] in the stacked value of SR before returning from interrupts with RETE.

3. RETS behaves incorrectly when MPU is enabled

RETS behaves incorrectly when MPU is enabled and MPU is configured so that system stack is not readable in unprivileged mode.

Fix/Workaround

Make system stack readable in unprivileged mode, or return from supervisor mode using rete instead of rets. This requires:

1. Changing the mode bits from 001 to 110 before issuing the instruction. Updating the mode bits to the desired value must be done using a single mtsr instruction so it is done atomically. Even if this step is generally described as not safe in the UC technical reference manual, it is safe in this very specific case.
2. Execute the RETE instruction.

4. Privilege violation when using interrupts in application mode with protected system stack

If the system stack is protected by the MPU and an interrupt occurs in application mode, an MPU DTLB exception will occur.

Fix/Workaround

Make a DTLB Protection (Write) exception handler which permits the interrupt request to be handled in privileged mode.

5. USART

6. ISO7816 info register US_NER cannot be read

The NER register always returns zero.

Fix/Workaround

None.

7. ISO7816 Mode T1: RX impossible after any TX

RX impossible after any TX.

Fix/Workaround

SOFT_RESET on RX+ Config US_MR + Config_US_CR.

8. The RTS output does not function correctly in hardware handshaking mode

The RTS signal is not generated properly when the USART receives data in hardware handshaking mode. When the Peripheral DMA receive buffer becomes full, the RTS output should go high, but it will stay low.

Fix/Workaround

Do not use the hardware handshaking mode of the USART. If it is necessary to drive the RTS output high when the Peripheral DMA receive buffer becomes full, use the normal mode of the USART. Configure the Peripheral DMA Controller to signal an interrupt when the receive buffer is full. In the interrupt handler code, write a one to the RTSDIS bit in the USART Control Register (CR). This will drive the RTS output high. After the next DMA transfer is started and a receive buffer is available, write a one to the RTSEN bit in the USART CR so that RTS will be driven low.

9. Corruption after receiving too many bits in SPI slave mode

If the USART is in SPI slave mode and receives too much data bits (ex: 9bits instead of 8 bits) by the SPI master, an error occurs. After that, the next reception may be corrupted even if the frame is correct and the USART has been disabled, reset by a soft reset and re-enabled.

Fix/Workaround

None.

10. USART slave synchronous mode external clock must be at least 9 times lower in frequency than CLK_USART

When the USART is operating in slave synchronous mode with an external clock, the frequency of the signal provided on CLK must be at least 9 times lower than CLK_USART.

Fix/Workaround

When the USART is operating in slave synchronous mode with an external clock, provide a signal on CLK that has a frequency at least 9 times lower than CLK_USART.

11. HMATRIX**12. In the PRAS and PRBS registers, the MxPR fields are only two bits**

In the PRAS and PRBS registers, the MxPR fields are only two bits wide, instead of four bits. The unused bits are undefined when reading the registers.

Fix/Workaround

Mask undefined bits when reading PRAS and PRBS.

- FLASHC**1. Reading from on-chip flash may fail after a flash fuse write operation (FLASHC LP, UP, WGPB, EGPB, SSB, PGPFB, EAGPF commands).**

After a flash fuse write operation (FLASHC LP, UP, WGPB, EGPB, SSB, PGPFB, EAGPF commands), the following flash read access may return corrupted data. This erratum does not affect write operations to regular flash memory.

Fix/Workaround

The flash fuse write operation (FLASHC LP, UP, WGPB, EGPB, SSB, PGPFB, EAGPF commands) must be issued from internal RAM. After the write operation, perform a dummy flash page write operation (FLASHC WP). Content and location of this page is not important

and filling the write buffer with all one (FFh) will leave the current flash content unchanged. It is then safe to read and fetch code from the flash.

- *DSP Operations*

1. Hardware breakpoints may corrupt MAC results

Hardware breakpoints on MAC instructions may corrupt the destination register of the MAC instruction.

Fix/Workaround

Place breakpoints on earlier or later instructions.

31.2.4 Rev. B

- PWM

- 1. PWM channel interrupt enabling triggers an interrupt**

When enabling a PWM channel that is configured with center aligned period (CALG=1), an interrupt is signalled.

Fix/Workaround
When using center aligned mode, enable the channel and read the status before channel interrupt is enabled.
- 2. PWN counter restarts at 0x0001**

The PWM counter restarts at 0x0001 and not 0x0000 as specified. Because of this the first PWM period has one more clock cycle.

Fix/Workaround

 - The first period is 0x0000, 0x0001, ..., period.
 - Consecutive periods are 0x0001, 0x0002, ..., period.
- 3. PWM update period to a 0 value does not work**

It is impossible to update a period equal to 0 by the using the PWM update register (PWM_CUPD).

Fix/Workaround
Do not update the PWM_CUPD register with a value equal to 0.
- 4. PWM channel status may be wrong if disabled before a period has elapsed**

Before a PWM period has elapsed, the read channel status may be wrong. The CHIDx-bit for a PWM channel in the PWM Enable Register will read '1' for one full PWM period even if the channel was disabled before the period elapsed. It will then read '0' as expected.

Fix/Workaround
Reading the PWM channel status of a disabled channel is only correct after a PWM period has elapsed.
- 5. The following alternate C functions PWM[4] on PA16 and PWM[6] on PA31 are not available on Rev B**

The following alternate C functions PWM[4] on PA16 and PWM[6] on PA31 are not available on Rev B.

Fix/Workaround
Do not use these PWM alternate functions on these pins.
- 6. SPI**
- 7. SPI Slave / PDCA transfer: no TX UNDERRUN flag**

There is no TX UNDERRUN flag available, therefore in SPI slave mode, there is no way to be informed of a character lost in transmission.

Fix/Workaround
For PDCA transfer: none.

8. SPI bad serial clock generation on 2nd chip_select when SCBR=1, CPOL=1, and NCPHA=0

When multiple chip selects (CS) are in use, if one of the baudrates equal 1 while one (CSRn.SCBR=1) of the others do not equal 1, and CSRn.CPOL=1 and CSRn.NCPHA=0, then an additional pulse will be generated on SCK.

Fix/Workaround

When multiple CS are in use, if one of the baudrates equals 1, the others must also equal 1 if CSRn.CPOL=1 and CSRn.NCPHA=0.

9. SPI Glitch on RXREADY flag in slave mode when enabling the SPI or during the first transfer

In slave mode, the SPI can generate a false RXREADY signal during enabling of the SPI or during the first transfer.

Fix/Workaround

1. Set slave mode, set required CPOL/CPHA.
2. Enable SPI.
3. Set the polarity CPOL of the line in the opposite value of the required one.
4. Set the polarity CPOL to the required one.
5. Read the RXHOLDING register.

Transfers can now begin and RXREADY will now behave as expected.

10. SPI CSNAAT bit 2 in register CSR0...CSR3 is not available

SPI CSNAAT bit 2 in register CSR0...CSR3 is not available.

Fix/Workaround

Do not use this bit.

11. SPI disable does not work in SLAVE mode

SPI disable does not work in SLAVE mode.

Fix/Workaround

Read the last received data, then perform a software reset by writing a one to the Software Reset bit in the Control Register (CR.SWRST).

- Power Manager

1. PLL Lock control does not work

PLL lock Control does not work.

Fix/Workaround

In PLL Control register, the bit 7 should be set in order to prevent unexpected behavior.

2. Wrong reset causes when BOD is activated

Setting the BOD enable fuse will cause the Reset Cause Register to list BOD reset as the reset source even though the part was reset by another source.

Fix/Workaround

Do not set the BOD enable fuse, but activate the BOD as soon as your program starts.

3. System Timer mask (Bit 16) of the PM CPUMASK register is not available

System Timer mask (Bit 16) of the PM CPUMASK register is not available.

Fix/Workaround

Do not use this bit.

- SSC

1. SSC does not trigger RF when data is low

The SSC cannot transmit or receive data when CKS = CKDIV and CKO = none, in TCMR or RCMR respectively.

Fix/Workaround

Set CKO to a value that is not "none" and bypass the output of the TK/RK pin with the GPIO.

- USB

1. USB No end of host reset signaled upon disconnection

In host mode, in case of an unexpected device disconnection whereas a usb reset is being sent by the usb controller, the UHCON.RESET bit may not be cleared by the hardware at the end of the reset.

Fix/Workaround

A software workaround consists in testing (by polling or interrupt) the disconnection (UHINT.DDISCI == 1) while waiting for the end of reset (UHCON.RESET == 0) to avoid being stuck.

2. USBFSM and UHADDR1/2/3 registers are not available

Do not use USBFSM register.

Fix/Workaround

Do not use USBFSM register and use HCON[6:0] field instead for all the pipes.

- Cycle counter

1. CPU Cycle Counter does not reset the COUNT system register on COMPARE match.

The device revision B does not reset the COUNT system register on COMPARE match. In this revision, the COUNT register is clocked by the CPU clock, so when the CPU clock stops, so does incrementing of COUNT.

Fix/Workaround

None.

- ADC

1. ADC possible miss on DRDY when disabling a channel

The ADC does not work properly when more than one channel is enabled.

Fix/Workaround

Do not use the ADC with more than one channel enabled at a time.

2. ADC OVRE flag sometimes not reset on Status Register read

The OVRE flag does not clear properly if read simultaneously to an end of conversion.

Fix/Workaround

None.

3. Sleep Mode activation needs additional A to D conversion

If the ADC sleep mode is activated when the ADC is idle the ADC will not enter sleep mode before after the next AD conversion.

Fix/Workaround

Activate the sleep mode in the mode register and then perform an AD conversion.

- *USART*

1. **USART Manchester Encoder Not Working**
Manchester encoding/decoding is not working.
Fix/Workaround
Do not use manchester encoding.
2. **USART RXBREAK problem when no timeguard**
In asynchronous mode the RXBREAK flag is not correctly handled when the timeguard is 0 and the break character is located just after the stop bit.
Fix/Workaround
If the NBSTOP is 1, timeguard should be different from 0.
3. **USART Handshaking: 2 characters sent / CTS rises when TX**
If CTS switches from 0 to 1 during the TX of a character, if the Holding register is not empty, the TXHOLDING is also transmitted.
Fix/Workaround
None.
4. **USART PDC and TIMEGUARD not supported in MANCHESTER**
Manchester encoding/decoding is not working.
Fix/Workaround
Do not use manchester encoding.
5. **USART SPI mode is non functional on this revision**
USART SPI mode is non functional on this revision.
Fix/Workaround
Do not use the USART SPI mode.

- *HMATRIX*

1. **HMatrix fixed priority arbitration does not work**
Fixed priority arbitration does not work.
Fix/Workaround
Use Round-Robin arbitration instead.

- *Clock characteristic*

1. **PBA max frequency**
The Peripheral bus A (PBA) max frequency is 30MHz instead of 60MHz.
Fix/Workaround
Do not set the PBA maximum frequency higher than 30MHz.

- *FLASHC*

1. **The address of Flash General Purpose Fuse Register Low (FGPFRLO) is 0xFFFE140C on revB instead of 0xFFFE1410**
The address of Flash General Purpose Fuse Register Low (FGPFRLO) is 0xFFFE140C on revB instead of 0xFFFE1410.
Fix/Workaround
None.

2. **The command Quick Page Read User Page(QPRUP) is not functional**
 The command Quick Page Read User Page(QPRUP) is not functional.
Fix/Workaround
 None.

3. **PAGEN Semantic Field for Program GP Fuse Byte is WriteData[7:0], ByteAddress[1:0] on revision B instead of WriteData[7:0], ByteAddress[2:0]**
 PAGEN Semantic Field for Program GP Fuse Byte is WriteData[7:0], ByteAddress[1:0] on revision B instead of WriteData[7:0], ByteAddress[2:0].
Fix/Workaround
 None.

4. **Reading from on-chip flash may fail after a flash fuse write operation (FLASHC LP, UP, WGPB, EGPB, SSB, PGPFB, EAGPF commands).**
 After a flash fuse write operation (FLASHC LP, UP, WGPB, EGPB, SSB, PGPFB, EAGPF commands), the following flash read access may return corrupted data. This erratum does not affect write operations to regular flash memory.
Fix/Workaround
 The flash fuse write operation (FLASHC LP, UP, WGPB, EGPB, SSB, PGPFB, EAGPF commands) must be issued from internal RAM. After the write operation, perform a dummy flash page write operation (FLASHC WP). Content and location of this page is not important and filling the write buffer with all one (FFh) will leave the current flash content unchanged. It is then safe to read and fetch code from the flash.

- 5.

- RTC

1. **Writes to control (CTRL), top (TOP) and value (VAL) in the RTC are discarded if the RTC peripheral bus clock (PBA) is divided by a factor of four or more relative to the HSB clock**
 Writes to control (CTRL), top (TOP) and value (VAL) in the RTC are discarded if the RTC peripheral bus clock (PBA) is divided by a factor of four or more relative to the HSB clock.
Fix/Workaround
 Do not write to the RTC registers using the peripheral bus clock (PBA) divided by a factor of four or more relative to the HSB clock.

2. **The RTC CLKEN bit (bit number 16) of CTRL register is not available**
 The RTC CLKEN bit (bit number 16) of CTRL register is not available.
Fix/Workaround
 Do not use the CLKEN bit of the RTC on Rev B.

- OCD

1. Stalled memory access instruction writeback fails if followed by a HW breakpoint

Consider the following assembly code sequence:

A

B

If a hardware breakpoint is placed on instruction B, and instruction A is a memory access instruction, register file updates from instruction A can be discarded.

Fix/Workaround

Do not place hardware breakpoints, use software breakpoints instead. Alternatively, place a hardware breakpoint on the instruction before the memory access instruction and then single step over the memory access instruction.

- Processor and Architecture

1. Local Bus to fast GPIO not available on silicon Rev B

Local bus is only available for silicon RevE and later.

Fix/Workaround

Do not use if silicon revision older than F.

2. Memory Protection Unit (MPU) is non functional

Memory Protection Unit (MPU) is non functional.

Fix/Workaround

Do not use the MPU.

3. Bus error should be masked in Debug mode

If a bus error occurs during debug mode, the processor will not respond to debug commands through the DINST register.

Fix/Workaround

A reset of the device will make the CPU respond to debug commands again.

4. Read Modify Write (RMW) instructions on data outside the internal RAM does not work

Read Modify Write (RMW) instructions on data outside the internal RAM does not work.

Fix/Workaround

Do not perform RMW instructions on data outside the internal RAM.

5. Need two NOPs instruction after instructions masking interrupts

The instructions following in the pipeline the instruction masking the interrupt through SR may behave abnormally.

Fix/Workaround

Place two NOPs instructions after each SSRF or MTSR instruction setting IxM or GM in SR

6. Clock connection table on Rev B

Here is the table of Rev B

Figure 31-1. Timer/Counter clock connections on RevB

| Source | Name | Connection |
|----------|--------------|------------------|
| Internal | TIMER_CLOCK1 | 32KHz Oscillator |
| | TIMER_CLOCK2 | PBA Clock / 4 |
| | TIMER_CLOCK3 | PBA Clock / 8 |
| | TIMER_CLOCK4 | PBA Clock / 16 |
| | TIMER_CLOCK5 | PBA Clock / 32 |
| External | XC0 | |
| | XC1 | |
| | XC2 | |

7. Spurious interrupt may corrupt core SR mode to exception

If the rules listed in the chapter 'Masking interrupt requests in peripheral modules' of the AVR32UC Technical Reference Manual are not followed, a spurious interrupt may occur. An interrupt context will be pushed onto the stack while the core SR mode will indicate an exception. A RETE instruction would then corrupt the stack.

Fix/Workaround

Follow the rules of the AVR32UC Technical Reference Manual. To increase software robustness, if an exception mode is detected at the beginning of an interrupt handler, change the stack interrupt context to an exception context and issue a RETE instruction.

8. CPU cannot operate on a divided slow clock (internal RC oscillator)

CPU cannot operate on a divided slow clock (internal RC oscillator).

Fix/Workaround

Do not run the CPU on a divided slow clock.

9. LDM instruction with PC in the register list and without ++ increments Rp

For LDM with PC in the register list: the instruction behaves as if the ++ field is always set, i.e. the pointer is always updated. This happens even if the ++ field is cleared. Specifically, the increment of the pointer is done in parallel with the testing of R12.

Fix/Workaround

None.

10. RETE instruction does not clear SREG[L] from interrupts

The RETE instruction clears SREG[L] as expected from exceptions.

Fix/Workaround

When using the STCOND instruction, clear SREG[L] in the stacked value of SR before returning from interrupts with RETE.

11. Exceptions when system stack is protected by MPU

RETS behaves incorrectly when MPU is enabled and MPU is configured so that system stack is not readable in unprivileged mode.

Fix/Workaround

Workaround 1: Make system stack readable in unprivileged mode,

or

Workaround 2: Return from supervisor mode using rete instead of rets. This requires: 1. Changing the mode bits from 001b to 110b before issuing the instruction.

Updating the mode bits to the desired value must be done using a single mtsr instruction so

it is done atomically. Even if this step is described in general as not safe in the UC technical reference guide, it is safe in this very specific case.

2. Execute the RETE instruction.

32. Datasheet Revision History

Please note that the referring page numbers in this section are referred to this document. The referring revision in this section are referring to the document revision.

32.1 Rev. L– 01/2012

1. Updated Mechanical Characteristics section.

32.2 Rev. K– 02/2011

1. Updated USB section.
2. Updated Configuration Summary section.
3. Updated Electrical Characteristics section.
4. Updated Errata section.

32.3 Rev. J– 12/2010

1. Updated USB section.
2. Updated USART section.
3. Updated TWI section.
4. Updated PWM section.
5. Updated Electrical Characteristics section.

32.4 Rev. I – 06/2010

1. Updated SPI section.
2. Updated Electrical Characteristics section.

32.5 Rev. H – 10/2009

1. Update datasheet architecture.
2. Add AT32UC3B0512 and AT32UC3B1512 devices description.

32.6 Rev. G – 06/2009

1. Open Drain Mode removed from GPIO section.
2. Updated Errata section.

32.7 Rev. F – 04/2008

1. Updated Errata section.

32.8 Rev. E – 12/2007

1. Updated Memory Protection section.

32.9 Rev. D – 11/2007

1. Updated Processor Architecture section.
2. Updated Electrical Characteristics section.

32.10 Rev. C – 10/2007

1. Updated Features sections.
2. Updated block diagram with local bus figure
3. Add schematic for HMatrix master/slave connection.
4. Updated Features sections with local bus.
5. Added SPI feature to USART section.
6. Updated USBB section.
7. Updated ADC trigger selection in ADC section.
8. Updated JTAG and Boundary Scan section with programming procedure.
9. Add description for silicon revision D

32.11 Rev. B – 07/2007

1. Updated registered trademarks
2. Updated address page.

32.12 Rev. A – 05/2007

1. Initial revision.

Table of Contents

| | | |
|----------|--|-----------|
| 1 | Description | 3 |
| 2 | Overview | 4 |
| | 2.1 Blockdiagram | 4 |
| 3 | Configuration Summary | 5 |
| 4 | Package and Pinout | 6 |
| | 4.1 Package | 6 |
| | 4.2 Peripheral Multiplexing on I/O lines | 7 |
| | 4.3 High Drive Current GPIO | 10 |
| 5 | Signals Description | 10 |
| | 5.1 JTAG pins | 13 |
| | 5.2 RESET_N pin | 14 |
| | 5.3 TWI pins | 14 |
| | 5.4 GPIO pins | 14 |
| | 5.5 High drive pins | 14 |
| | 5.6 Power Considerations | 14 |
| 6 | Processor and Architecture | 17 |
| | 6.1 Features | 17 |
| | 6.2 AVR32 Architecture | 17 |
| | 6.3 The AVR32UC CPU | 18 |
| | 6.4 Programming Model | 22 |
| | 6.5 Exceptions and Interrupts | 26 |
| | 6.6 Module Configuration | 30 |
| 7 | Memories | 31 |
| | 7.1 Embedded Memories | 31 |
| | 7.2 Physical Memory Map | 31 |
| | 7.3 Peripheral Address Map | 32 |
| | 7.4 CPU Local Bus Mapping | 33 |
| 8 | Boot Sequence | 34 |
| | 8.1 Starting of clocks | 34 |
| | 8.2 Fetching of initial instructions | 34 |
| 9 | Power Manager (PM) | 35 |
| | 9.1 Features | 35 |

| | | |
|-----------|--|-----------|
| 9.2 | Description | 35 |
| 9.3 | Block Diagram | 36 |
| 9.4 | Product Dependencies | 37 |
| 9.5 | Functional Description | 37 |
| 9.6 | User Interface | 49 |
| 10 | Real Time Counter (RTC) | 72 |
| 10.1 | Features | 72 |
| 10.2 | Overview | 72 |
| 10.3 | Block Diagram | 72 |
| 10.4 | Product Dependencies | 72 |
| 10.5 | Functional Description | 73 |
| 10.6 | User Interface | 75 |
| 11 | Watchdog Timer (WDT) | 84 |
| 11.1 | Features | 84 |
| 11.2 | Overview | 84 |
| 11.3 | Block Diagram | 84 |
| 11.4 | Product Dependencies | 84 |
| 11.5 | Functional Description | 85 |
| 11.6 | User Interface | 85 |
| 12 | Interrupt Controller (INTC) | 88 |
| 12.1 | Features | 88 |
| 12.2 | Overview | 88 |
| 12.3 | Block Diagram | 88 |
| 12.4 | Product Dependencies | 89 |
| 12.5 | Functional Description | 89 |
| 12.6 | User Interface | 92 |
| 12.7 | Interrupt Request Signal Map | 96 |
| 13 | External Interrupt Controller (EIC) | 98 |
| 13.1 | Features | 98 |
| 13.2 | Overview | 98 |
| 13.3 | Block Diagram | 99 |
| 13.4 | I/O Lines Description | 99 |
| 13.5 | Product Dependencies | 99 |
| 13.6 | Functional Description | 100 |
| 13.7 | User Interface | 104 |

| | | |
|-----------|---|------------|
| 14 | Flash Controller (FLASHC) | 120 |
| 14.1 | Features | 120 |
| 14.2 | Overview | 120 |
| 14.3 | Product dependencies | 120 |
| 14.4 | Functional description | 121 |
| 14.5 | Flash commands | 123 |
| 14.6 | General-purpose fuse bits | 125 |
| 14.7 | Security bit | 127 |
| 14.8 | User Interface | 128 |
| 14.9 | Fuses Settings | 136 |
| 14.10 | Bootloader Configuration | 137 |
| 14.11 | Serial Number | 137 |
| 14.12 | Module configuration | 137 |
| 15 | HSB Bus Matrix (HMATRIX) | 138 |
| 15.1 | Features | 138 |
| 15.2 | Overview | 138 |
| 15.3 | Product Dependencies | 138 |
| 15.4 | Functional Description | 138 |
| 15.5 | User Interface | 142 |
| 15.6 | Bus Matrix Connections | 150 |
| 16 | Peripheral DMA Controller (PDCA) | 152 |
| 16.1 | Features | 152 |
| 16.2 | Overview | 152 |
| 16.3 | Block Diagram | 153 |
| 16.4 | Product Dependencies | 153 |
| 16.5 | Functional Description | 154 |
| 16.6 | User Interface | 157 |
| 16.7 | Module Configuration | 170 |
| 17 | General-Purpose Input/Output Controller (GPIO) | 171 |
| 17.1 | Features | 171 |
| 17.2 | Overview | 171 |
| 17.3 | Block Diagram | 171 |
| 17.4 | Product Dependencies | 171 |
| 17.5 | Functional Description | 172 |
| 17.6 | User Interface | 176 |

| | | |
|-----------|---|------------|
| 17.7 | Programming Examples | 191 |
| 17.8 | Module Configuration | 193 |
| 18 | <i>Serial Peripheral Interface (SPI)</i> | 194 |
| 18.1 | Features | 194 |
| 18.2 | Overview | 194 |
| 18.3 | Block Diagram | 195 |
| 18.4 | Application Block Diagram | 195 |
| 18.5 | Signal Description | 196 |
| 18.6 | Product Dependencies | 196 |
| 18.7 | Functional Description | 196 |
| 18.8 | User Interface | 206 |
| 19 | <i>Two-Wire Interface (TWI)</i> | 218 |
| 19.1 | Features | 218 |
| 19.2 | Overview | 218 |
| 19.3 | List of Abbreviations | 219 |
| 19.4 | Block Diagram | 219 |
| 19.5 | Application Block Diagram | 220 |
| 19.6 | I/O Lines Description | 220 |
| 19.7 | Product Dependencies | 220 |
| 19.8 | Functional Description | 221 |
| 19.9 | Modes of Operation | 221 |
| 19.10 | Master Mode | 222 |
| 19.11 | Using the Peripheral DMA Controller | 226 |
| 19.12 | Multi-master Mode | 234 |
| 19.13 | Slave Mode | 237 |
| 19.14 | User Interface | 245 |
| 20 | <i>Synchronous Serial Controller (SSC)</i> | 259 |
| 20.1 | Features | 259 |
| 20.2 | Overview | 259 |
| 20.3 | Block Diagram | 260 |
| 20.4 | Application Block Diagram | 260 |
| 20.5 | I/O Lines Description | 261 |
| 20.6 | Product Dependencies | 261 |
| 20.7 | Functional Description | 261 |
| 20.8 | SSC Application Examples | 273 |

| | | |
|-----------|---|------------|
| 20.9 | User Interface | 275 |
| 21 | <i>Universal Synchronous Asynchronous Receiver Transmitter (USART)</i> | 297 |
| 21.1 | Features | 297 |
| 21.2 | Overview | 297 |
| 21.3 | Block Diagram | 298 |
| 21.4 | I/O Lines Description | 299 |
| 21.5 | Product Dependencies | 299 |
| 21.6 | Functional Description | 300 |
| 21.7 | User Interface | 327 |
| 21.8 | Module Configuration | 351 |
| 22 | <i>USB Interface (USBB)</i> | 352 |
| 22.1 | Features | 352 |
| 22.2 | Overview | 352 |
| 22.3 | Block Diagram | 353 |
| 22.4 | Application Block Diagram | 355 |
| 22.5 | I/O Lines Description | 357 |
| 22.6 | Product Dependencies | 358 |
| 22.7 | Functional Description | 359 |
| 22.8 | User Interface | 393 |
| 23 | <i>Timer/Counter (TC)</i> | 472 |
| 23.1 | Features | 472 |
| 23.2 | Overview | 472 |
| 23.3 | Block Diagram | 473 |
| 23.4 | I/O Lines Description | 473 |
| 23.5 | Product Dependencies | 473 |
| 23.6 | Functional Description | 474 |
| 23.7 | User Interface | 489 |
| 23.8 | Module Configuration | 512 |
| 24 | <i>Pulse Width Modulation Controller (PWM)</i> | 513 |
| 24.1 | Features | 513 |
| 24.2 | Description | 513 |
| 24.3 | Block Diagram | 514 |
| 24.4 | I/O Lines Description | 514 |
| 24.5 | Product Dependencies | 515 |

| | | |
|-----------|---|------------|
| 24.6 | Functional Description | 516 |
| 24.7 | User Interface | 524 |
| 25 | <i>Analog-to-Digital Converter (ADC)</i> | 539 |
| 25.1 | Features | 539 |
| 25.2 | Overview | 539 |
| 25.3 | Block Diagram | 540 |
| 25.4 | I/O Lines Description | 540 |
| 25.5 | Product Dependencies | 540 |
| 25.6 | Functional Description | 541 |
| 25.7 | User Interface | 546 |
| 25.8 | Module Configuration | 559 |
| 26 | <i>Audio Bitstream DAC (ABDAC)</i> | 560 |
| 26.1 | Features | 560 |
| 26.2 | Overview | 560 |
| 26.3 | Block Diagram | 561 |
| 26.4 | I/O Lines Description | 561 |
| 26.5 | Product Dependencies | 561 |
| 26.6 | Functional Description | 562 |
| 26.7 | User Interface | 565 |
| 27 | <i>Programming and Debugging</i> | 573 |
| 27.1 | Overview | 573 |
| 27.2 | Service Access Bus | 573 |
| 27.3 | On-Chip Debug (OCD) | 575 |
| 27.4 | JTAG and Boundary-scan (JTAG) | 582 |
| 27.5 | JTAG Instruction Summary | 590 |
| 27.6 | JTAG Data Registers | 605 |
| 27.7 | SAB address map | 606 |
| 28 | <i>Electrical Characteristics</i> | 607 |
| 28.1 | Absolute Maximum Ratings* | 607 |
| 28.2 | DC Characteristics | 608 |
| 28.3 | Regulator Characteristics | 610 |
| 28.4 | Analog Characteristics | 610 |
| 28.5 | Power Consumption | 614 |
| 28.6 | System Clock Characteristics | 617 |
| 28.7 | Oscillator Characteristics | 618 |



| | | |
|-----------|---|------------|
| 28.8 | ADC Characteristics | 620 |
| 28.9 | USB Transceiver Characteristics | 622 |
| 28.10 | JTAG Characteristics | 623 |
| 28.11 | SPI Characteristics | 624 |
| 28.12 | Flash Memory Characteristics | 626 |
| 29 | <i>Mechanical Characteristics</i> | 627 |
| 29.1 | Thermal Considerations | 627 |
| 29.2 | Package Drawings | 628 |
| 29.3 | Soldering Profile | 632 |
| 30 | <i>Ordering Information</i> | 633 |
| 31 | <i>Errata</i> | 634 |
| 31.1 | AT32UC3B0512, AT32UC3B1512 | 634 |
| 31.2 | AT32UC3B0256, AT32UC3B0128, AT32UC3B064, AT32UC3B1256, AT32UC3B1128, AT32UC3B164 | 646 |
| 32 | <i>Datasheet Revision History</i> | 674 |
| 32.1 | Rev. L– 01/2012 | 674 |
| 32.2 | Rev. K– 02/2011 | 674 |
| 32.3 | Rev. J– 12/2010 | 674 |
| 32.4 | Rev. I – 06/2010 | 674 |
| 32.5 | Rev. H – 10/2009 | 674 |
| 32.6 | Rev. G – 06/2009 | 675 |
| 32.7 | Rev. F – 04/2008 | 675 |
| 32.8 | Rev. E – 12/2007 | 675 |
| 32.9 | Rev. D – 11/2007 | 675 |
| 32.10 | Rev. C – 10/2007 | 675 |
| 32.11 | Rev. B – 07/2007 | 675 |
| 32.12 | Rev. A – 05/2007 | 676 |

**Atmel Corporation**

2325 Orchard Parkway
San Jose, CA 95131
USA

Tel: (+1)(408) 441-0311

Fax: (+1)(408) 487-2600

www.atmel.com

Atmel Asia Limited

Unit 1-5 & 16, 19/F
BEA Tower, Millennium City 5
418 Kwun Tong Road
Kwun Tong, Kowloon
HONG KONG

Tel: (+852) 2245-6100

Fax: (+852) 2722-1369

Atmel Munich GmbH

Business Campus
Parking 4
D-85748 Garching b. Munich
GERMANY

Tel: (+49) 89-31970-0

Fax: (+49) 89-3194621

Atmel Japan

16F, Shin Osaki Kangyo Bldg.
1-6-4 Osaka Shinagawa-ku
Tokyo 104-0032

JAPAN

Tel: (+81) 3-6417-0300

Fax: (+81) 3-6417-0370

© 2012 Atmel Corporation. All rights reserved.

Atmel®, Atmel logo and combinations thereof AVR®, Qtouch®, Adjacent Key Suppression®, AKS®, and others are registered trademarks or trademarks of Atmel Corporation or its subsidiaries. Other terms and product names may be trademarks of others.

Disclaimer: The information in this document is provided in connection with Atmel products. No license, express or implied, by estoppel or otherwise, to any intellectual property right is granted by this document or in connection with the sale of Atmel products. **EXCEPT AS SET FORTH IN THE ATMEL TERMS AND CONDITIONS OF SALES LOCATED ON THE ATMEL WEBSITE, ATMEL ASSUMES NO LIABILITY WHATSOEVER AND DISCLAIMS ANY EXPRESS, IMPLIED OR STATUTORY WARRANTY RELATING TO ITS PRODUCTS INCLUDING, BUT NOT LIMITED TO, THE IMPLIED WARRANTY OF MERCHANTABILITY, FITNESS FOR A PARTICULAR PURPOSE, OR NON-INFRINGEMENT. IN NO EVENT SHALL ATMEL BE LIABLE FOR ANY DIRECT, INDIRECT, CONSEQUENTIAL, PUNITIVE, SPECIAL OR INCIDENTAL DAMAGES (INCLUDING, WITHOUT LIMITATION, DAMAGES FOR LOSS AND PROFITS, BUSINESS INTERRUPTION, OR LOSS OF INFORMATION) ARISING OUT OF THE USE OR INABILITY TO USE THIS DOCUMENT, EVEN IF ATMEL HAS BEEN ADVISED OF THE POSSIBILITY OF SUCH DAMAGES.** Atmel makes no representations or warranties with respect to the accuracy or completeness of the contents of this document and reserves the right to make changes to specifications and product descriptions at any time without notice. Atmel does not make any commitment to update the information contained herein. Unless specifically provided otherwise, Atmel products are not suitable for, and shall not be used in, automotive applications. Atmel products are not intended, authorized, or warranted for use as components in applications intended to support or sustain life.

Mouser Electronics

Authorized Distributor

Click to View Pricing, Inventory, Delivery & Lifecycle Information:

Atmel:

[AT32UC3B1128-AUT](#) [AT32UC3B0256-Z2UT](#) [AT32UC3B0128-A2UT](#) [AT32UC3B064-Z2UT](#) [AT32UC3B064-A2UT](#)
[AT32UC3B164-Z1UT](#) [AT32UC3B0256-A2UT](#) [AT32UC3B1256-Z1UT](#) [AT32UC3B164-AUT](#) [AT32UC3B0128-Z2UT](#)
[AT32UC3B1128-Z1UT](#) [AT32UC3B1256-AUT](#) [AT32UC3B0512-A2UR](#) [AT32UC3B0512-A2UT](#) [AT32UC3B0512-Z2UR](#)
[AT32UC3B0512-Z2UT](#) [AT32UC3B1512-Z1UR](#) [AT32UC3B1512-Z1UT](#) [AT32UC3B0128-A2UR](#) [AT32UC3B0128-Z2UR](#)
[AT32UC3B0256-A2UR](#) [AT32UC3B0256-Z2UR](#) [AT32UC3B064-A2UR](#) [AT32UC3B064-Z2UR](#) [AT32UC3B1128-AUR](#)
[AT32UC3B1128-Z1UR](#) [AT32UC3B1256-AUR](#) [AT32UC3B1256-Z1UR](#) [AT32UC3B164-AUR](#) [AT32UC3B164-Z1UR](#)
[AT32UC3B0128AU-A2UT](#) [AT32UC3B0128AU-Z2UR](#) [AT32UC3B0512AU-Z2UR](#)