

# Multiphase PWM Regulator for AMD Fusion™ Mobile CPUs Using SVI 2.0

## ISL62771

The ISL62771 is fully compliant with AMD Fusion SVI 2.0 and provides a complete solution for microprocessor and graphics processor core power. The ISL62771 controller supports two Voltage Regulators (VRs) with three integrated gate drivers. The Core VR supports 2-, or 1-phase configurations while the Northbridge VR supports 1-phase operation. The two VRs share a serial control bus to communicate with the AMD CPU and achieve lower cost and smaller board area compared with two-chip solutions.

The PWM modulator is based on Intersil's Robust Ripple Regulator R3™ Technology. Compared to traditional modulators, the R3 modulator can automatically change switching frequency for faster transient settling time during load transients and improved light load efficiency.

The ISL62771 has several other key features. Both outputs support DCR current sensing with single NTC thermistor for DCR temperature compensation or accurate resistor current sensing. Both outputs utilize remote voltage sense, adjustable switching frequency, OC protection and power-good.

## Applications

- AMD Fusion CPU/GPU and APU Core Power
- Notebook computers

## Features

- Supports AMD SVI 2.0 serial data bus interface
  - SVC frequency range 100kHz to 20MHz
- Dual output controller with integrated drivers
- Precision voltage regulation
  - 0.5% system accuracy over-temperature
  - 0.5V to 1.55V in 6.25mV steps
  - Enhanced load line accuracy
- Supports multiple current sensing methods
  - Lossless inductor DCR current sensing
  - Precision resistor current sensing
- Programmable 1- or 2-phase for the core output
- Adaptive body diode conduction time reduction
- Superior noise immunity and transient response
- Output current and voltage telemetry
- Differential remote voltage sensing
- High efficiency across entire load range
- Programmable VID offset and droop on both outputs
- Programmable switching frequency for both outputs
- Excellent dynamic current balance between phases
- Protection: OCP/WOC, OVP, PGOOD and thermal monitor
- Small footprint 40 Ld 5x5 TQFN package
  - Pb-free (RoHS compliant)

## Core Performance

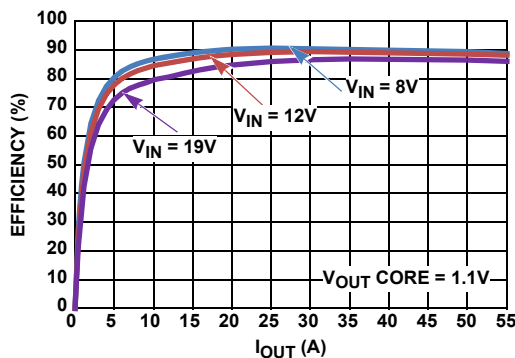

FIGURE 1. EFFICIENCY vs LOAD

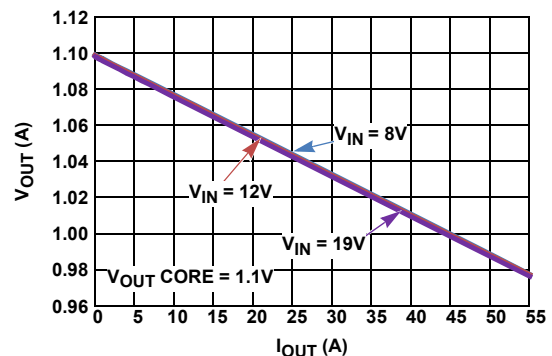

FIGURE 2. V<sub>OUT</sub> vs LOAD

## Table of Contents

<b>Simplified Application Circuit for Mid-Power CPUs</b> .....	<b>3</b>
<b>Simplified Application Circuit for Low Power CPUs [1+1 Configuration]</b> .....	<b>4</b>
<b>Simplified Application Circuit for Low Power CPUs [1+1 Configuration]</b> .....	<b>5</b>
<b>Block Diagram</b> .....	<b>6</b>
<b>Pin Configuration</b> .....	<b>7</b>
<b>Pin Descriptions</b> .....	<b>7</b>
<b>Ordering Information</b> .....	<b>9</b>
<b>Absolute Maximum Ratings</b> .....	<b>10</b>
<b>Thermal Information</b> .....	<b>10</b>
<b>Recommended Operating Conditions</b> .....	<b>10</b>
<b>Electrical Specifications</b> .....	<b>10</b>
<b>Gate Driver Timing Diagram</b> .....	<b>12</b>
<b>Theory of Operation</b> .....	<b>13</b>
Multiphase R3™ Modulator .....	13
Diode Emulation and Period Stretching .....	14
Channel Configuration .....	14
Power-on Reset .....	14
Start-up Timing .....	15
Voltage Regulation and Load Line Implementation .....	15
Differential Sensing .....	16
Phase Current Balancing .....	16
Modes of Operation .....	18
Dynamic Operation .....	18
Adaptive Body Diode Conduction Time Reduction .....	18
<b>Resistor Configuration Options</b> .....	<b>18</b>
VR Offset Programming .....	18
CCM Switching Frequency .....	19
AMD Serial VID Interface 2.0 .....	19
Pre-PWROK Metal VID .....	19
SVI Interface Active .....	19
VID-on-the-Fly Transition .....	20
SVI Data Communication Protocol .....	20
SVI Bus Protocol .....	22
Power States .....	22
Dynamic Load Line Slope Trim .....	22
Dynamic Offset Trim .....	23
<b>Telemetry</b> .....	<b>23</b>
<b>Protection Features</b> .....	<b>23</b>
Overcurrent .....	23
Current-Balance .....	24
Undervoltage .....	24
Overvoltage .....	24
Thermal Monitor [NTC, NTC_NB] .....	24
Fault Recovery .....	25
Interface Pin Protection .....	25
<b>Key Component Selection</b> .....	<b>25</b>
Inductor DCR Current-Sensing Network .....	25
Resistor Current-Sensing Network .....	27
Overcurrent Protection .....	27
Load Line Slope .....	28
Compensator .....	28
Current Balancing .....	29
Thermal Monitor Component Selection .....	29
<b>Layout Guidelines</b> .....	<b>30</b>
PCB Layout Considerations .....	30
<b>Revision History</b> .....	<b>34</b>
<b>About Intersil</b> .....	<b>34</b>
<b>Package Outline Drawing</b> .....	<b>35</b>

## Simplified Application Circuit for Mid-Power CPUs

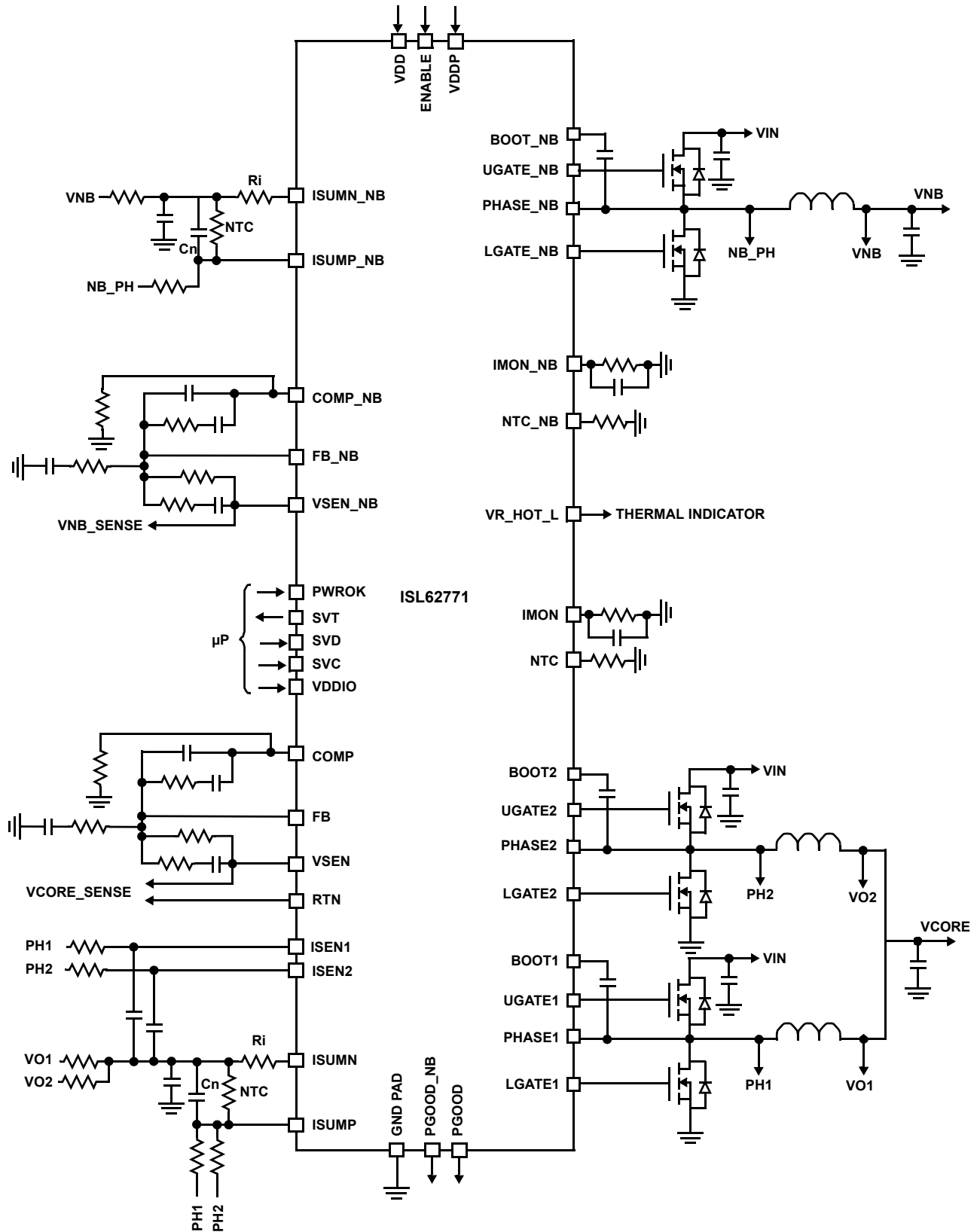

FIGURE 3. TYPICAL APPLICATION CIRCUIT USING DCR SENSING

# ISL62771

## Simplified Application Circuit for Low Power CPUs [1+1 Configuration]

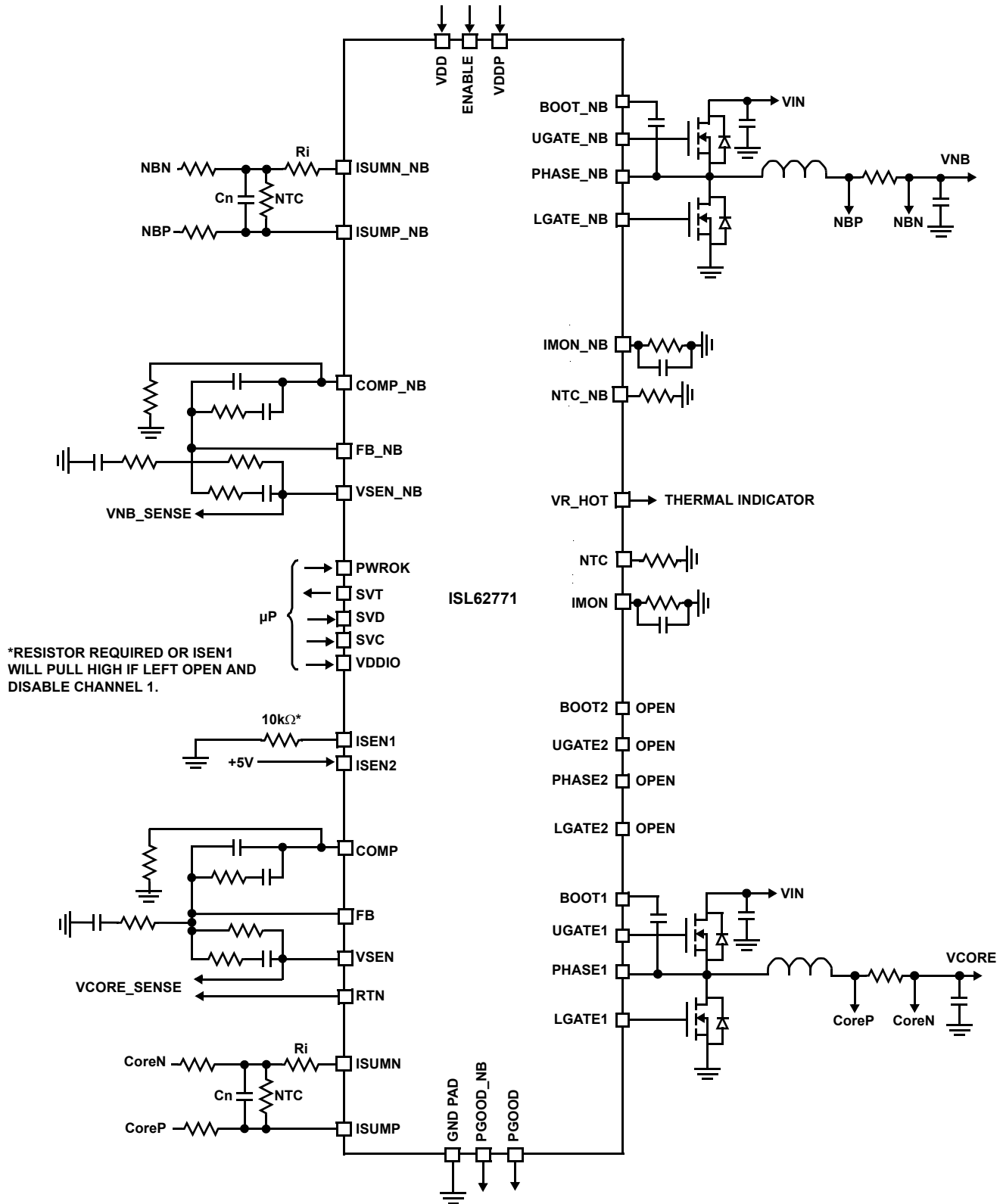

FIGURE 4. TYPICAL APPLICATION CIRCUIT USING RESISTOR SENSING

# ISL62771

## Simplified Application Circuit for Low Power CPUs [1+1 Configuration]

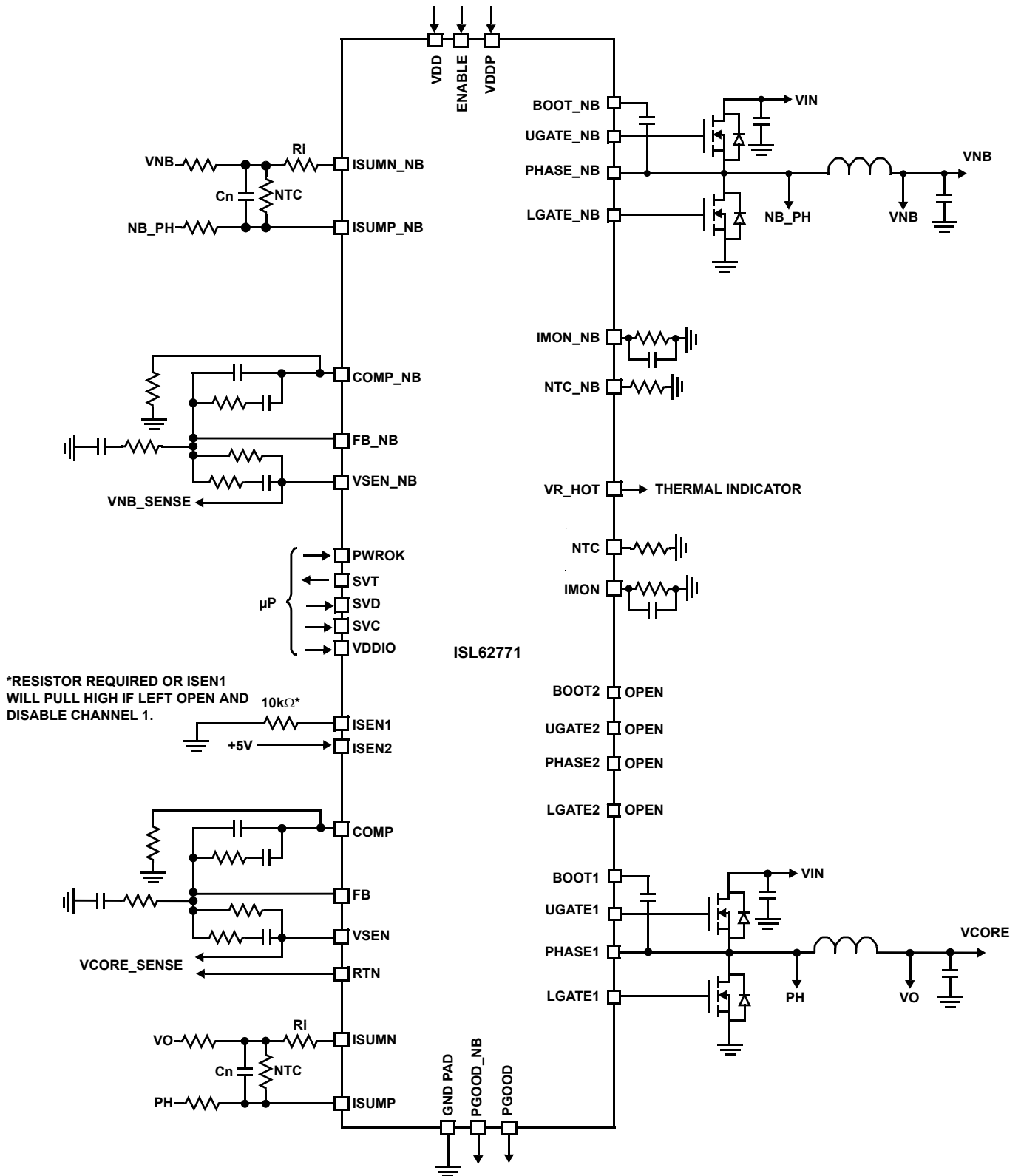
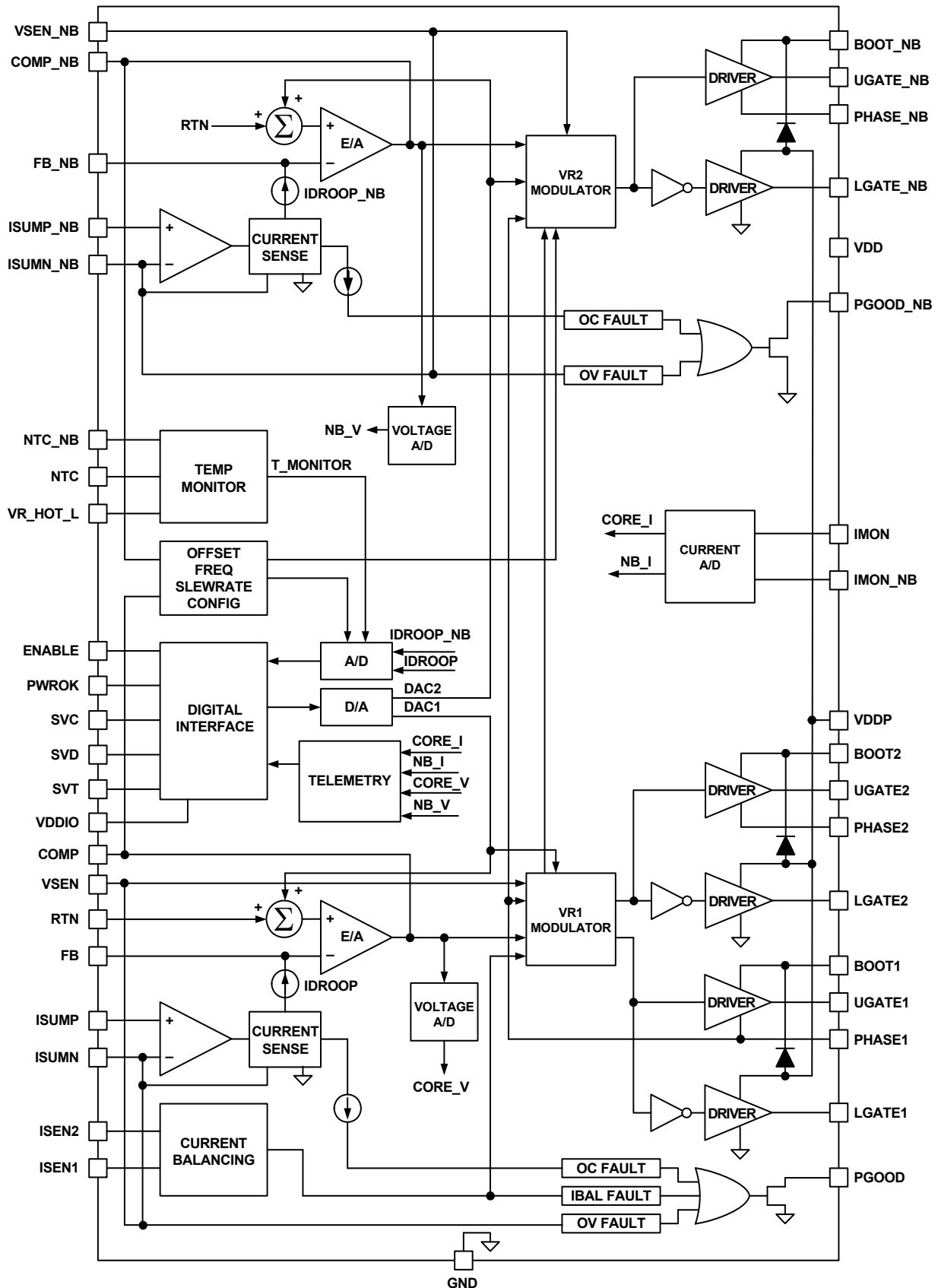

FIGURE 5. TYPICAL APPLICATION CIRCUIT USING INDUCTOR DCR SENSING

## Block Diagram



# ISL62771

## Pin Configuration

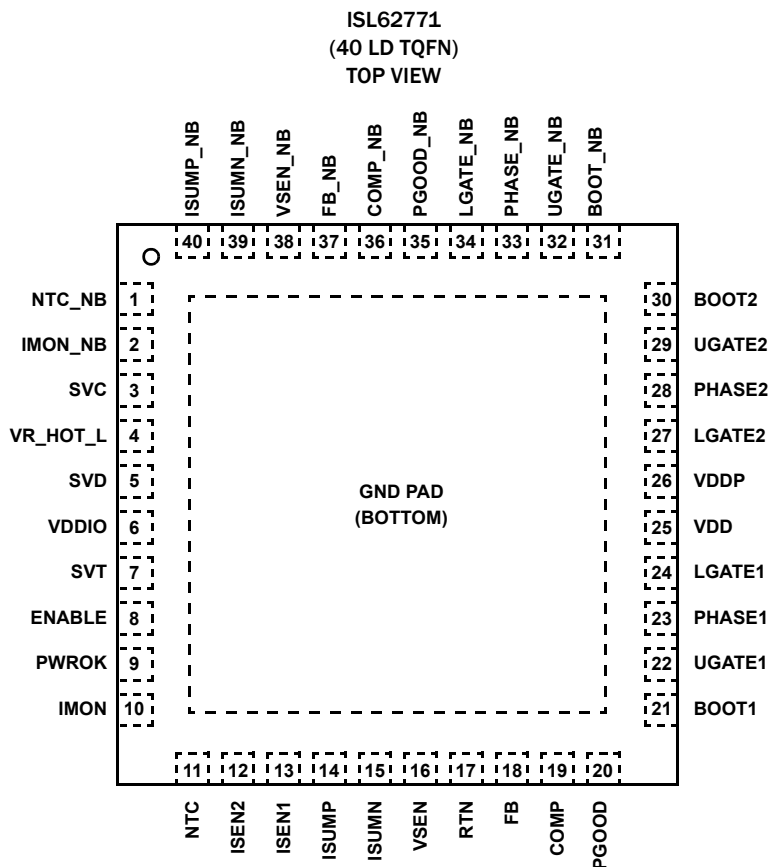

## Pin Descriptions

PIN NUMBER	SYMBOL	DESCRIPTION
1	NTC_NB	Thermistor input to VR_HOT_L circuit to monitor Northbridge VR temperature.
2	IMON_NB	Northbridge output current monitor. A current proportional to the Northbridge VR output current is sourced from this pin.
3	SVC	Serial VID clock input from the CPU processor master device.
4	VR_HOT_L	Thermal indicator signal to AMD CPU. Thermal overload open-drain output indicator active LOW.
5	SVD	Serial VID data bidirectional signal from the CPU processor master device to the VR.
6	VDDIO	VDDIO is the processor memory interface power rail and this pin serves as the reference to the controller IC for this processor I/O signal level.
7	SVT	Serial VID Telemetry (SVT) data line input to the CPU from the controller IC. Telemetry and VID-on-the-fly complete signal provided on from this pin.
8	ENABLE	Enable input. A high level logic on this pin enables both VRs.
9	PWROK	System power-good input. When this pin is high, the SVI 2 interface is active and the I <sup>2</sup> C protocol is running. While this pin is low, the SVC and SVD input states determine the pre-PWROK metal VID. This pin must be low prior to the ISL62771 PGOOD output going high per the AMD SVI 2.0 Controller Guidelines.
10	IMON	Core output current monitor. A current proportional to the Core VR output current is sourced from this pin.
11	NTC	Thermistor input to VR_HOT_L circuit to monitor Core VR temperature.
12	ISEN2	Individual current sensing for Channel 2 of the Core VR. When ISEN2 is pulled to +5V, the controller disables Channel 2 and the Core VR runs in single-phase mode.

# ISL62771

## Pin Descriptions (Continued)

PIN NUMBER	SYMBOL	DESCRIPTION
13	ISEN1	Individual current sensing for Channel 1 of the Core VR. If ISEN2 is tied to +5V, this pin cannot be left open and must be tied to GND with a 10kΩ resistor. If ISEN1 is tied to +5V, the Core portion of the IC is shut down.
14	ISUMP	Noninverting input of the transconductance amplifier for current monitor and load line of Core output.
15	ISUMN	Inverting input of the transconductance amplifier for current monitor and load line of Core output.
16	VSEN	Output voltage sense pin for the Core controller. Connect to the +sense pin of the microprocessor die.
17	RTN	Output voltage sense return pin for both Core VR and Northbridge VR. Connect to the -sense pin of the microprocessor die.
18	FB	Output voltage feedback to the inverting input of the Core controller error amplifier.
19	COMP	Core controller error amplifier output. A resistor from COMP to GND sets the Core VR offset voltage.
20	PGOOD	Open-drain output to indicate the Core portion of the IC is ready to supply regulated voltage. Pull-up externally to VDD or 3.3V through a resistor.
21	BOOT1	Connect an MLCC capacitor across the BOOT1 and the PHASE1 pins. The boot capacitor is charged, through an internal boot diode connected from the VDDP pin to the BOOT1 pin, each time the PHASE1 pin drops below VDDP minus the voltage dropped across the internal boot diode.
22	UGATE1	Output of the Phase 1 high-side MOSFET gate driver of the Core VR. Connect the UGATE1 pin to the gate of the Phase 1 high-side MOSFET(s).
23	PHASE1	Current return path for the Phase 1 high-side MOSFET gate driver of VR1. Connect the PHASE1 pin to the node consisting of the high-side MOSFET source, the low-side MOSFET drain and the output inductor of Phase 1.
24	LGATE1	Output of the Phase 1 low-side MOSFET gate driver of the Core VR. Connect the LGATE1 pin to the gate of the Phase 1 low-side MOSFET(s).
25	VDD	5V bias power. A resistor [2Ω] and a decoupling capacitor should be used from the +5V supply. A high quality, X7R dielectric MLCC capacitor is recommended.
26	VDDP	Input voltage bias for the internal gate drivers. Connect +5V to the VDDP pin. Decouple with at least 1μF of capacitance to GND. A high quality, X7R dielectric MLCC capacitor is recommended.
27	LGATE2	Output of the Phase 2 low-side MOSFET gate driver of the Core VR. Connect the LGATE2 pin to the gate of the Phase 2 low-side MOSFET(s).
28	PHASE2	Current return path for the Phase 2 high-side MOSFET gate driver of the Core VR. Connect the PHASE2 pin to the node consisting of the high-side MOSFET source, the low-side MOSFET drain and the output inductor of Phase 2.
29	UGATE2	Output of the Phase 2 high-side MOSFET gate driver of the Core VR. Connect the UGATE2 pin to the gate of the Phase 2 high-side MOSFET(s).
30	BOOT2	Connect an MLCC capacitor across the BOOT2 and PHASE2 pins. The boot capacitor is charged, through an internal boot diode connected from the VDDP pin to the BOOT2 pin, each time the PHASE2 pin drops below VDDP minus the voltage dropped across the internal boot diode.
31	BOOT_NB	Boot connection of the Northbridge VR. Connect an MLCC capacitor across the BOOT1_NB and the PHASE_NB pins. The boot capacitor is charged, through an internal boot diode connected from the VDDP pin to the BOOT_NB pin, each time the PHASE_NB pin drops below VDDP minus the voltage dropped across the internal boot diode.
32	UGATE_NB	High-side MOSFET gate driver of the Northbridge VR. Connect the UGATE_NB pin to the gate of the high-side MOSFET(s) of the Northbridge VR.
33	PHASE_NB	Phase connection of the Northbridge VR. Current return path for the high-side MOSFET gate driver of the floating internal driver. Connect the PHASE_NB pin to the node consisting of the high-side MOSFET source, the low-side MOSFET drain and the output inductor of the Northbridge VR.
34	LGATE_NB	Low-side MOSFET gate driver of the Northbridge VR. Connect the LGATE_NB pin to the gate of the low-side MOSFET(s) of the Northbridge VR.
35	PGOOD_NB	Open-drain output to indicate the Northbridge portion of the IC is ready to supply regulated voltage. Pull-up externally to VDDP or 3.3V through a resistor.



# ISL62771

## Pin Descriptions (Continued)

PIN NUMBER	SYMBOL	DESCRIPTION
36	COMP_NB	Northbridge VR error amplifier output. A resistor from COMP_NB to GND sets the Northbridge VR offset voltage and is used to set the switching frequency for the Core VR and Northbridge VR.
37	FB_NB	Output voltage feedback to the inverting input of the Northbridge controller error amplifier.
38	VSEN_NB	Output voltage sense pin for the Northbridge controller. Connect to the +sense pin of the microprocessor die.
39	ISUMN_NB	Inverting input of the transconductance amplifier for current monitor and load line of the Northbridge VR.
40	ISUMP_NB	Noninverting input of the transconductance amplifier for current monitor and load line of the Northbridge VR.
	GND (Bottom Pad)	Signal common of the IC. All signals are referenced to the GND pin.

## Ordering Information

PART NUMBER (Notes 1, 2, 3)	PART MARKING	TEMP. RANGE (°C)	PACKAGE (RoHS Compliant)	PKG. DWG. #
ISL62771HRTZ	62771 HRTZ	-10 to +100	40 Ld 5x5 TQFN	L40.5x5
ISL62771IRTZ	62771 IRTZ	-40 to +100	40 Ld 5x5 TQFN	L40.5x5

### NOTES:

1. Add "-T\*" suffix for tape and reel. Please refer to [TB347](#) for details on reel specifications.
2. These Intersil Pb-free plastic packaged products employ special Pb-free material sets, molding compounds/die attach materials and 100% matte tin plate plus anneal (e3 termination finish, which is RoHS compliant and compatible with both SnPb and Pb-free soldering operations). Intersil Pb-free products are MSL classified at Pb-free peak reflow temperatures that meet or exceed the Pb-free requirements of IPC/JEDEC J STD-020.
3. For Moisture Sensitivity Level (MSL), please see device information page for [ISL62771](#). For more information on MSL please see tech brief [TB363](#).

# ISL62771

## Absolute Maximum Ratings

Supply Voltage, $V_{DD}$ , $V_{DDP}$ .....	-0.3V to +7V
Battery Voltage, $V_{IN}$ .....	+28V
Boot Voltage (BOOT) .....	-0.3V to +33V
Boot to Phase Voltage (BOOT-PHASE) .....	-0.3V to +7V (DC)
.....	-0.3V to +9V(<10ns)
Phase Voltage (PHASE) .....	-7V (<20ns Pulse Width, 10 $\mu$ J)
UGATE Voltage (UGATE) .....	PHASE - 0.3V (DC) to BOOTPHASE - 5V
.....	(<20ns Pulse Width, 10 $\mu$ J) to BOOT LGATE Voltage
.....	-2.5V (<20ns Pulse Width, 5 $\mu$ J) to VDD + 0.3V
All Other Pins .....	-0.3V to (VDD + 0.3V)
Open-drain Outputs, PGOOD, PGOOD_NB, VR_HOT_L .....	-0.3V to +7V

## Thermal Information

Thermal Resistance (Typical)	$\theta_{JA}$ ( $^{\circ}$ C/W)	$\theta_{JC}$ ( $^{\circ}$ C/W)
40 Ld TQFN Package (Notes 4, 5) .....	33	3
Maximum Junction Temperature .....	+150 $^{\circ}$ C	
Maximum Storage Temperature Range .....	-65 $^{\circ}$ C to +150 $^{\circ}$ C	
Maximum Junction Temperature (Plastic Package) .....	+150 $^{\circ}$ C	
Storage Temperature Range .....	-65 $^{\circ}$ C to +150 $^{\circ}$ C	
Pb-free Reflow Profile .....	see <a href="#">TB493</a>	

## Recommended Operating Conditions

Supply Voltage, $V_{DD}$ .....	+5V $\pm$ 5%
Battery Voltage, $V_{IN}$ .....	+4.5V to 25V
Ambient Temperature	
HRTZ .....	-10 $^{\circ}$ C to +100 $^{\circ}$ C
IRTZ .....	-40 $^{\circ}$ C to +100 $^{\circ}$ C
Junction Temperature	
HRTZ .....	-10 $^{\circ}$ C to +125 $^{\circ}$ C
IRTZ .....	-40 $^{\circ}$ C to +125 $^{\circ}$ C

**CAUTION:** Do not operate at or near the maximum ratings listed for extended periods of time. Exposure to such conditions may adversely impact product reliability and result in failures not covered by warranty.

### NOTES:

- $\theta_{JA}$  is measured in free air with the component mounted on a high effective thermal conductivity test board with "direct attach" features. See Tech Brief [TB379](#).
- For  $\theta_{JC}$ , the "case temp" location is the center of the exposed metal pad on the package underside.

**Electrical Specifications** Operating Conditions:  $V_{DD} = 5V$ ,  $T_A = -40^{\circ}$ C to +100 $^{\circ}$ C,  $f_{SW} = 300kHz$ , unless otherwise noted. **Boldface** limits apply over the operating temperature range, **-40 $^{\circ}$ C to +100 $^{\circ}$ C**.

PARAMETER	SYMBOL	TEST CONDITIONS	MIN (Note 6)	TYP	MAX (Note 6)	UNITS
<b>INPUT POWER SUPPLY</b>						
+5V Supply Current	$I_{VDD}$	ENABLE = 1V		8	<b>11</b>	mA
		ENABLE = 0V			<b>1</b>	$\mu$ A
<b>POWER-ON-RESET THRESHOLDS</b>						
VDD POR Threshold	$V_{DD\_PORr}$	$V_{DD}$ rising		4.35	<b>4.5</b>	V
	$V_{DD\_PORf}$	$V_{DD}$ falling	<b>4.00</b>	4.15		V
<b>SYSTEM AND REFERENCES</b>						
System Accuracy	HRTZ %Error ( $V_{OUT}$ )	No load; closed loop, active mode range, VID = 0.75V to 1.55V,	-0.5		+0.5	%
		VID = 0.25V to 0.74375V	-10		+10	mV
	IRTZ %Error ( $V_{OUT}$ )	No load; closed loop, active mode range, VID = 0.75V to 1.55V	-0.8		+0.8	%
		VID = 0.25V to 0.74375V	-12		+12	mV
Maximum Output Voltage	$V_{OUT(max)}$	VID = [00000000]		1.55		V
Minimum Output Voltage	$V_{OUT(min)}$	VID = [11111111]		0.0		V
<b>CHANNEL FREQUENCY</b>						
Nominal Channel Frequency	$f_{SW(nom)}$		<b>280</b>	300	<b>320</b>	kHz
<b>AMPLIFIERS</b>						
Current-sense Amplifier Input Offset	HRTZ	$I_{FB} = 0A$	<b>-0.15</b>		<b>+0.15</b>	mV
	IRTZ	$I_{FB} = 0A$	<b>-0.20</b>		<b>+0.20</b>	mV
Error Amp DC Gain	$A_{v0}$			119		dB
Error Amp Gain-bandwidth Product	GBW	$C_L = 20pF$		17		MHz
<b>ISEN</b>						
Input Bias Current				20		nA

# ISL62771

**Electrical Specifications** Operating Conditions:  $V_{DD} = 5V$ ,  $T_A = -40^\circ C$  to  $+100^\circ C$ ,  $f_{SW} = 300kHz$ , unless otherwise noted. **Boldface limits apply over the operating temperature range,  $-40^\circ C$  to  $+100^\circ C$ .** (Continued)

PARAMETER	SYMBOL	TEST CONDITIONS	MIN (Note 6)	TYP	MAX (Note 6)	UNITS
<b>POWER-GOOD (PGOOD, PGOOD_NB) AND PROTECTION MONITORS</b>						
PGOOD Low Voltage	$V_{OL}$	$I_{PGOOD} = 4mA$			<b>0.4</b>	V
PGOOD Leakage Current	$I_{OH}$	$PGOOD = 3.3V$	<b>-1</b>		<b>1</b>	$\mu A$
PWROK High Threshold				750		mV
VR_HOT_L Pull-down				11		$\Omega$
PWROK Leakage Current					<b>1</b>	$\mu A$
VR_HOT_L Leakage Current					<b>1</b>	$\mu A$
<b>GATE DRIVER</b>						
UGATE Pull-up Resistance	$R_{UGPU}$	200mA source current		1.0	<b>1.5</b>	$\Omega$
UGATE Source Current	$I_{UGSRC}$	UGATE - PHASE = 2.5V		2.0		A
UGATE Sink Resistance	$R_{UGPD}$	250mA sink current		1.0	<b>1.5</b>	$\Omega$
UGATE Sink Current	$I_{UGSNK}$	UGATE - PHASE = 2.5V		2.0		A
LGATE Pull-up Resistance	$R_{LGPU}$	250mA source current		1.0	<b>1.5</b>	$\Omega$
LGATE Source Current	$I_{LGSRC}$	LGATE - VSSP = 2.5V		2.0		A
LGATE Sink Resistance	$R_{LGPD}$	250mA sink current		0.5	<b>0.9</b>	$\Omega$
LGATE Sink Current	$I_{LGSNK}$	LGATE - VSSP = 2.5V		4.0		A
UGATE to LGATE Deadtime	$t_{UGFLGR}$	UGATE falling to LGATE rising, no load		23		ns
LGATE to UGATE Deadtime	$t_{LGFUGR}$	LGATE falling to UGATE rising, no load		28		ns
<b>PROTECTION</b>						
Overvoltage Threshold	$OV_H$	VSEN rising above setpoint for $>1\mu s$	<b>275</b>	325	<b>375</b>	mV
Undervoltage Threshold	$OV_H$	VSEN falls below setpoint for $>1\mu s$	<b>275</b>	325	<b>375</b>	mV
Current Imbalance Threshold		One ISEN above another ISEN for $>1.2ms$		9		mV
Way Overcurrent Trip Threshold [IMONx Current Based Detection]	$IMONx_{WOC}$	All states, $I_{DROOP} = 60\mu A$ , $R_{IMON} = 135k\Omega$		15		$\mu A$
Overcurrent Trip Threshold [IMONx Voltage Based Detection]	$V_{IMONx\_OCP}$	All states, $I_{DROOP} = 45\mu A$ , $I_{IMONx} = 11.25\mu A$ , $R_{IMON} = 135k\Omega$	<b>1.485</b>	1.51	<b>1.535</b>	V
<b>LOGIC THRESHOLDS</b>						
ENABLE Input Low	$V_{IL}$				<b>1</b>	V
ENABLE Input High	$V_{IH}$	HRTZ	1.6			V
	$V_{IH}$	IRTZ	1.65			V
ENABLE Leakage Current	$I_{ENABLE}$	ENABLE = 0V	<b>-1</b>	0	<b>1</b>	$\mu A$
		ENABLE = 1V		18	<b>35</b>	$\mu A$
SVT Impedance				50		$\Omega$
SVC Frequency Range			<b>0.1</b>		<b>20</b>	MHz
SVC, SVD Input Low	$V_{IL}$	% of VDDIO			<b>30</b>	%
SVC, SVD Input High	$V_{IH}$	% of VDDIO	<b>70</b>			%
SVC, SVD Leakage		ENABLE = 0V, SVC, SVD = 0V and 1V	<b>-1</b>		<b>1</b>	$\mu A$
		ENABLE = 1V, SVC, SVD = 1V	<b>-5</b>		<b>1</b>	$\mu A$
		ENABLE = 1V, SVC, SVD = 0V	<b>-35</b>	-20	<b>-5</b>	$\mu A$
<b>THERMAL MONITOR</b>						
NTC Source Current		NTC = 0.6V	<b>27</b>	30	<b>33</b>	$\mu A$
NTC Thermal Warning Voltage			<b>600</b>	640	<b>680</b>	mV
NTC Thermal Warning Voltage Hysteresis				20		mV
NTC Thermal Shutdown Voltage			<b>530</b>	580	<b>630</b>	mV

# ISL62771

**Electrical Specifications** Operating Conditions:  $V_{DD} = 5V$ ,  $T_A = -40^\circ C$  to  $+100^\circ C$ ,  $f_{SW} = 300kHz$ , unless otherwise noted. **Boldface limits apply over the operating temperature range,  $-40^\circ C$  to  $+100^\circ C$ .** (Continued)

PARAMETER	SYMBOL	TEST CONDITIONS	MIN (Note 6)	TYP	MAX (Note 6)	UNITS
<b>SLEW RATE</b>						
VID-on-the-Fly Slew Rate			<b>8</b>	10	<b>12</b>	mV/ $\mu s$
Soft-start Slew Rate				10		mV/ $\mu s$

NOTE:

6. Compliance to datasheet limits is assured by one or more methods: production test, characterization and/or design.

## Gate Driver Timing Diagram

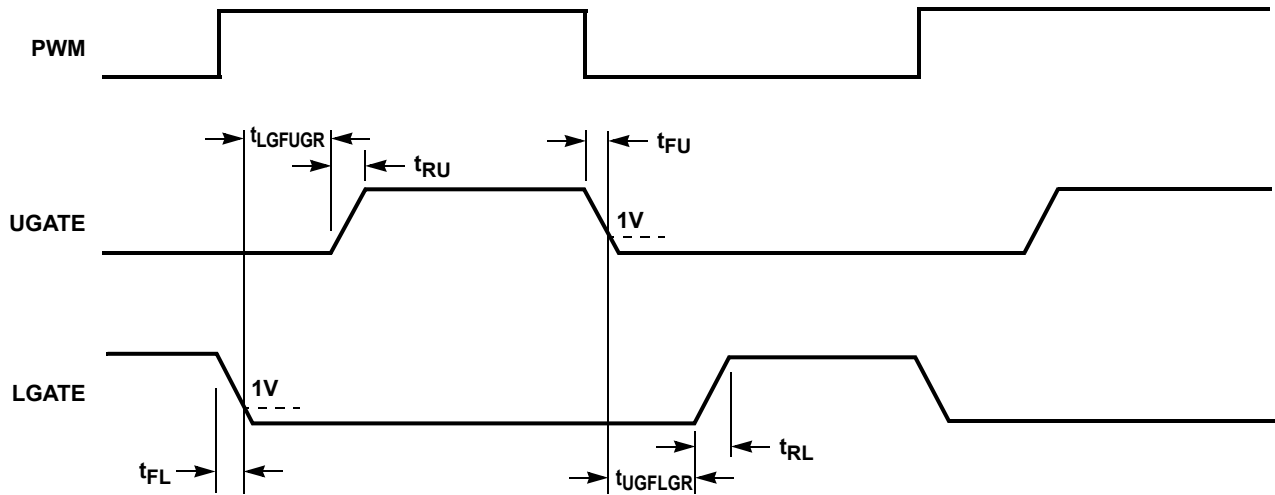

FIGURE 6. GATE DRIVER TIMING DIAGRAM

# Theory of Operation

## Multiphase R3™ Modulator

The ISL62771 is a multiphase regulator implementing two voltage regulators, CORE VR and Northbridge (NB) VR, on one chip controlled by AMD's SVI2 protocol. The CORE VR can be programmed for 1- or 2-phase operation. The Northbridge VR only supports 1-phase operation. Both regulators use the Intersil patented R3™ (Robust Ripple Regulator) modulator. The R3™ modulator combines the best features of fixed frequency PWM and hysteretic PWM while eliminating many of their shortcomings. [Figure 7](#) conceptually shows the multiphase R3™ modulator circuit and [Figure 8](#) shows the operation principles.

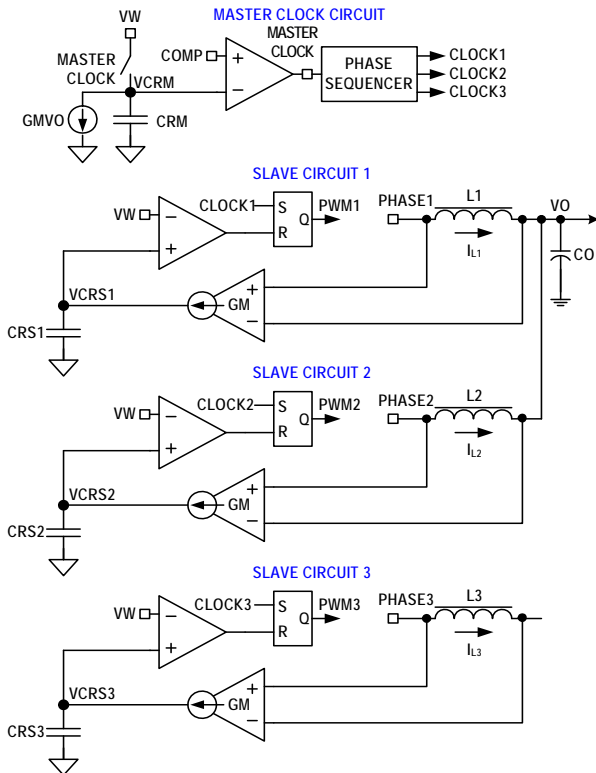

FIGURE 7. R3™ MODULATOR CIRCUIT

Inside the IC, the modulator uses the master clock circuit to generate the clocks for the slave circuits. The modulator discharges the ripple capacitor  $C_{rm}$  with a current source equal to  $g_m V_o$ , where  $g_m$  is a gain factor.  $C_{rm}$  voltage  $V_{CRM}$  is a sawtooth waveform traversing between the VW and COMP voltages. It resets to VW when it hits COMP and generates a one-shot master clock signal. A phase sequencer distributes the master clock signal to the slave circuits. In this example, the CORE VR is in 3-phase mode, the master clock signal is distributed to the three phases and the Clock 1~3 signals will be 120° out-of-phase. If the Core VR is in 2-phase mode, the master clock signal is distributed to Phases 1 and 2 and the Clock1 and Clock2 signals will be 180° out-of-phase. If the Core VR is in 1-phase mode, the master clock signal will be distributed to Phase 1 only and be the Clock1 signal.

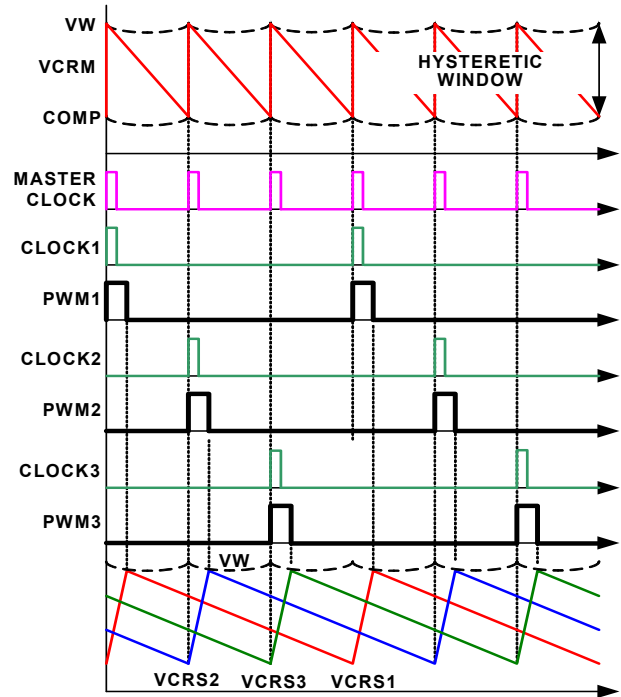

FIGURE 8. R3™ MODULATOR OPERATION PRINCIPLES IN STEADY STATE

Each slave circuit has its own ripple capacitor  $C_{rs}$ , whose voltage mimics the inductor ripple current. A  $g_m$  amplifier converts the inductor voltage into a current source to charge and discharge  $C_{rs}$ . The slave circuit turns on its PWM pulse upon receiving the clock signal and the current source charges  $C_{rs}$ . When  $C_{rs}$  voltage  $V_{CRS}$  hits VW, the slave circuit turns off the PWM pulse and the current source discharges  $C_{rs}$ .

Since the controller works with  $V_{CRS}$ , which are large amplitude and noise-free synthesized signals, it achieves lower phase jitter than conventional hysteretic mode and fixed PWM mode controllers. Unlike conventional hysteretic mode converters, the error amplifier allows the ISL62771 to maintain a 0.5% output voltage accuracy.

[Figure 9](#) shows the operation principles during load insertion response. The COMP voltage rises during load insertion, generating the master clock signal more quickly, so the PWM pulses turn on earlier, increasing the effective switching frequency. This allows for higher control loop bandwidth than conventional fixed frequency PWM controllers. The VW voltage rises as the COMP voltage rises, making the PWM pulses wider. During load release response, the COMP voltage falls. It takes the master clock circuit longer to generate the next master clock signal so the PWM pulse is held off until needed. The VW voltage falls as the COMP voltage falls, reducing the current PWM pulse width. This kind of behavior gives the ISL62771 excellent response speed.

The fact that all the phases share the same VW window voltage, also ensures excellent dynamic current balance among phases.

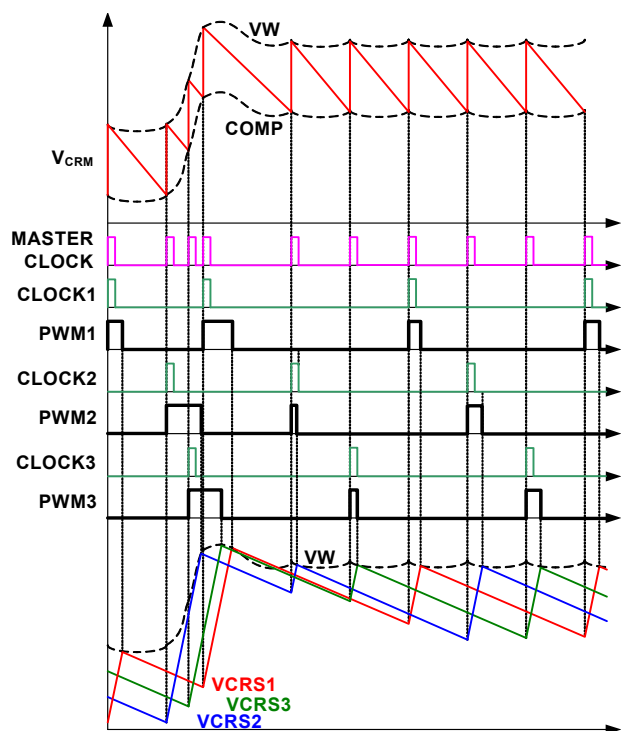

FIGURE 9. R3™ MODULATOR OPERATION PRINCIPLES IN LOAD INSERTION RESPONSE

## Diode Emulation and Period Stretching

The ISL62771 can operate in Diode Emulation (DE) mode to improve light-load efficiency. In DE mode, the low-side MOSFET conducts when the current is flowing from source-to-drain and does not allow reverse current, thus emulating a diode. Figure 10 shows that when LGATE is on, the low-side MOSFET carries current, creating negative voltage on the phase node due to the voltage drop across the ON-resistance. The ISL62771 monitors the current by monitoring the phase node voltage. It turns off LGATE when the phase node voltage reaches zero to prevent the inductor current from reversing the direction and creating unnecessary power loss.

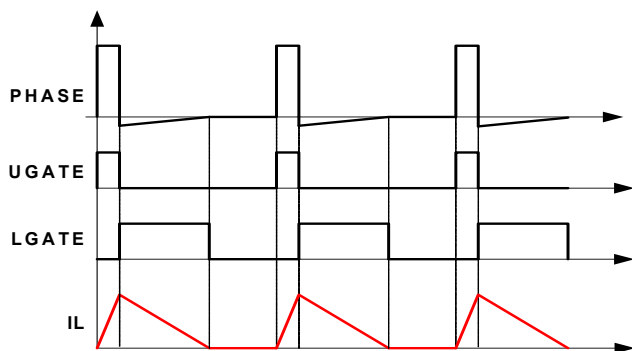

FIGURE 10. DIODE EMULATION

If the load current is light enough (see Figure 10), the inductor current reaches and stays at zero before the next phase node pulse and the regulator is in discontinuous conduction mode (DCM). If the load current is heavy enough, the inductor current will never reach 0A and the regulator is in CCM, although the controller is in DE mode.

Figure 11 shows the operation principle in diode emulation mode at light load. The load gets incrementally lighter in the three cases from top to bottom. The PWM on-time is determined by the VW window size and therefore is the same, making the inductor current triangle the same in the three cases. The ISL62771 clamps the ripple capacitor voltage  $V_{CRS}$  in DE mode to make it mimic the inductor current. It takes the COMP voltage longer to hit  $V_{CRS}$ , naturally stretching the switching period. The inductor current triangles move farther apart such that the inductor current average value is equal to the load current. The reduced switching frequency helps increase light-load efficiency.

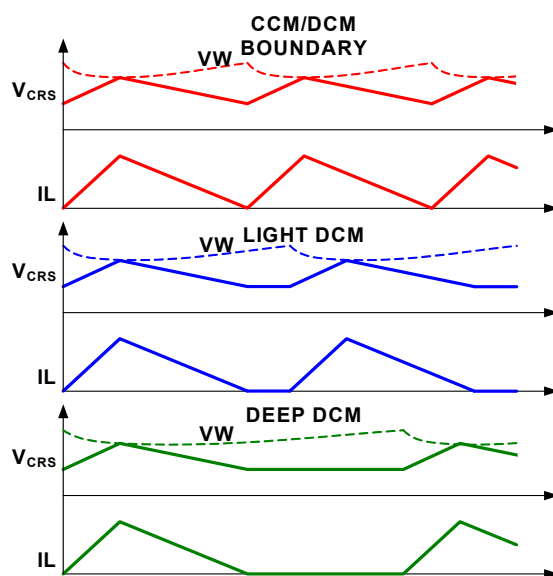

FIGURE 11. PERIOD STRETCHING

## Channel Configuration

Individual PWM channels of the Core VR can be disabled by connecting the ISENx pin of the channel not required to +5V. For example, placing the controller in a 1+1 configuration as shown in Figure 3 on page 3 requires ISEN2 of the Core VR to be tied to +5V. This disables Channel 2 of the Core VR. ISEN1 must be tied through a 10kΩ resistor to GND to prevent this pin from pulling high and disabling the channel. Connecting ISEN1 to +5V will disable the Core VR output.

## Power-on Reset

Before the controller has sufficient bias to guarantee proper operation, the ISL62771 requires a +5V input supply tied to VDD and VDDP to exceed the VDD rising power-on reset (POR) threshold. Once this threshold is reached or exceeded, the ISL62771 has enough bias to check the state of the SVI inputs once ENABLE is taken high. Hysteresis between the rising and the falling thresholds assure the ISL62771 does not inadvertently turn off unless the bias voltage drops substantially (see “Electrical Specifications” on page 10). Note that VIN must be present for the controller to drive the output voltage.

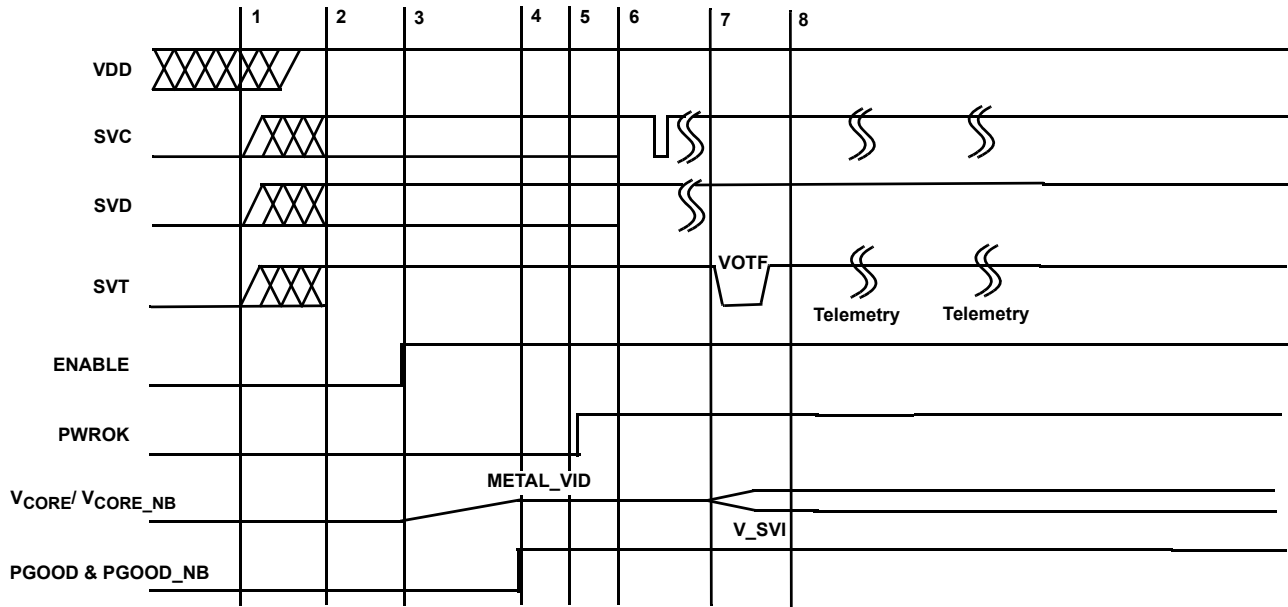

Interval 1 to 2: ISL62771 waits to POR.  
 Interval 2 to 3: SVC and SVD are externally set to pre-Metal VID code.  
 Interval 3 to 4: ENABLE locks pre-Metal VID code. Both outputs soft-start to this level.  
 Interval 4 to 5: PGOOD signal goes HIGH, indicating proper operation.  
 Interval 5 to 6: PGOOD and PGOOD\_NB high is detected and PWROK is taken high. The ISL62771 is prepared for SVI commands.  
 Interval 6 to 7: SVC and SVD data lines communicate change in VID code.  
 Interval 7 to 8: ISL62771 responds to VID-ON-THE-FLY code change and issues a VOTF for positive VID changes.  
 Post 8: Telemetry is clocked out of the ISL62771.

FIGURE 12. SVI INTERFACE TIMING DIAGRAM: TYPICAL PRE-PWROK METAL VID START-UP

## Start-up Timing

With the controller's VDD POR threshold exceeded and  $V_{IN}$  voltage present, the start-up sequence begins when ENABLE exceeds the logic high threshold. Figure 13 shows the typical start-up timing of Core and Northbridge VRs. The ISL62771 uses a digital soft-start to ramp-up the DAC to the voltage programmed by the Metal VID. PGOOD is asserted high at the end of the ramp-up. Similar results occur if ENABLE is tied to VDD, with the soft-start sequence starting 8ms after VDD crosses the POR threshold.

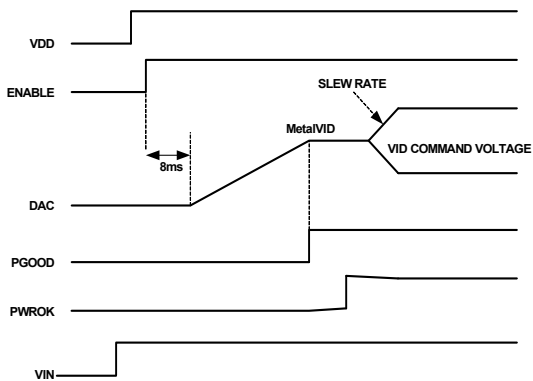

FIGURE 13. TYPICAL SOFT-START WAVEFORMS

## Voltage Regulation and Load Line Implementation

After the soft-start sequence, the ISL62771 regulates the output voltages to the pre-PWROK metal VID programmed, see Table 5. The ISL62771 controls the no load output voltage to an accuracy of  $\pm 0.5\%$  over the range of 0.75V to 1.55V. A differential amplifier allows voltage sensing for precise voltage regulation at the microprocessor die.

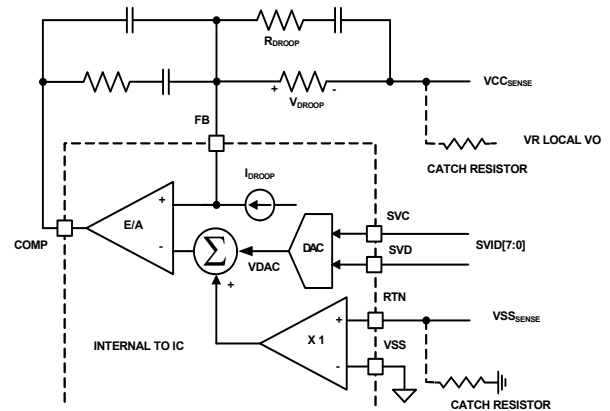

FIGURE 14. DIFFERENTIAL SENSING AND LOAD LINE IMPLEMENTATION



As the load current increases from zero, the output voltage droops from the VID programmed value by an amount proportional to the load current, to achieve the load line.

The ISL62771 can sense the inductor current through the intrinsic DC Resistance (DCR) of the inductors, as shown in [Figures 3](#) and [5](#), or through resistors in series with the inductors as shown in [Figure 4](#). In both methods, capacitor  $C_n$  voltage represents the total inductor current. An amplifier converts  $C_n$  voltage into an internal current source with the gain set by resistor  $R_i$ , see [Equation 1](#). This ISUM current is used for load line implementation, current monitoring on the IMON pins and overcurrent protection.

$$I_{sum} = \frac{V_{Cn}}{R_i} \quad (EQ. 1)$$

[Figure 14](#) shows the load line implementation. The ISL62771 drives a current source ( $I_{droop}$ ) out of the FB pin, as described by [Equation 2](#).

$$I_{droop} = \frac{5}{4} \times I_{sum} = \frac{5}{4} \times \frac{V_{Cn}}{R_i} \quad (EQ. 2)$$

When using inductor DCR current sensing, a single NTC element is used to compensate the positive temperature coefficient of the copper winding, thus sustaining the load line accuracy with reduced cost.

$I_{droop}$  flows through resistor  $R_{droop}$  and creates a voltage drop as shown in [Equation 3](#).

$$V_{droop} = R_{droop} \times I_{droop} \quad (EQ. 3)$$

$V_{droop}$  is the droop voltage required to implement load line. Changing  $R_{droop}$  or scaling  $I_{droop}$  can change the load line slope. Since  $I_{sum}$  sets the overcurrent protection level, it is recommended to first scale  $I_{sum}$  based on OCP requirement, then select an appropriate  $R_{droop}$  value to obtain the desired load line slope.

## Differential Sensing

[Figure 14](#) also shows the differential voltage sensing scheme.  $V_{CCSENSE}$  and  $V_{SSSENSE}$  are the remote voltage sensing signals from the processor die. A unity gain differential amplifier senses the  $V_{SSSENSE}$  voltage and adds it to the DAC output. The error amplifier regulates the inverting and non-inverting input voltages to be equal as shown in [Equation 4](#):

$$V_{CCSENSE} + V_{droop} = V_{DAC} + V_{SSSENSE} \quad (EQ. 4)$$

Rewriting [Equation 4](#) and substituting [Equation 3](#) gives [Equation 5](#). The exact equation required for load line implementation.

$$V_{CCSENSE} - V_{SSSENSE} = V_{DAC} - R_{droop} \times I_{droop} \quad (EQ. 5)$$

The  $V_{CCSENSE}$  and  $V_{SSSENSE}$  signals come from the processor die. The feedback is an open circuit in the absence of the processor. As [Figure 14](#) shows, it is recommended to add a “catch” resistor to feed the VR local output voltage back to the compensator and to add another “catch” resistor to connect the VR local output ground

to the RTN pin. These resistors, typically 10Ω~100Ω, provide voltage feedback if the system is powered up without a processor installed.

## Phase Current Balancing

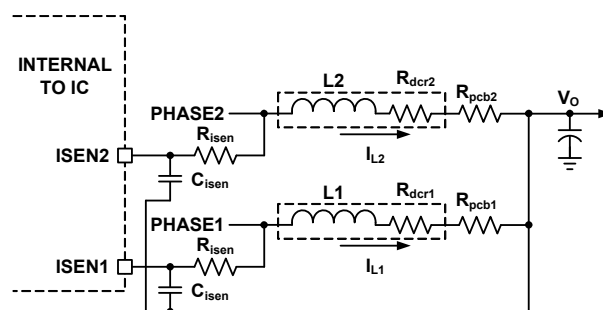

FIGURE 15. CURRENT BALANCING CIRCUIT

The ISL62771 monitors individual phase average current by monitoring the ISEN1 and ISEN2 voltages. [Figure 15](#) shows the recommended current balancing circuit for DCR sensing. Each phase node voltage is averaged by a low-pass filter consisting of  $R_{isen}$  and  $C_{isen}$  and is presented to the corresponding ISEN pin.  $R_{isen}$  should be routed to the inductor phase-node pad in order to eliminate the effect of phase node parasitic PCB DCR.

[Equations 6](#) and [7](#) give the ISEN pin voltages:

$$V_{ISEN1} = (R_{dcr1} + R_{pcb1}) \times I_{L1} \quad (EQ. 6)$$

$$V_{ISEN2} = (R_{dcr2} + R_{pcb2}) \times I_{L2} \quad (EQ. 7)$$

Where  $R_{dcr1}$  and  $R_{dcr2}$  are inductor DCR;  $R_{pcb1}$  and  $R_{pcb2}$  are parasitic PCB DCR between the inductor output side pad and the output voltage rail; and  $I_{L1}$  and  $I_{L2}$  are inductor average currents.

The ISL62771 adjusts the phase pulse-width relative to the other phases to make  $V_{ISEN1} = V_{ISEN2}$ , thus to achieve  $I_{L1} = I_{L2}$ , when  $R_{dcr1} = R_{dcr2}$  and  $R_{pcb1} = R_{pcb2}$ .

Using the same components for L1 and L2 provides a good match of  $R_{dcr1}$  and  $R_{dcr2}$ . Board layout determines  $R_{pcb1}$  and  $R_{pcb2}$ . It is recommended to have a symmetrical layout for the power delivery path between each inductor and the output voltage rail, such that  $R_{pcb1} = R_{pcb2}$ .

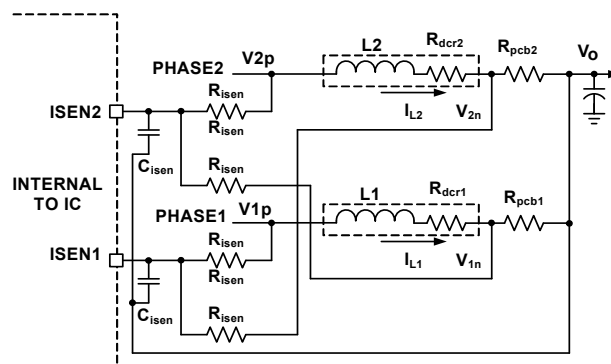

FIGURE 16. DIFFERENTIAL-SENSING CURRENT BALANCING CIRCUIT



Sometimes it is difficult to implement symmetrical layout. For the circuit shown in [Figure 15](#), asymmetric layout causes different  $R_{pcb1}$  and  $R_{pcb2}$  values, thus creating a current imbalance. [Figure 16](#) shows a differential sensing current balancing circuit recommended for ISL62771. The current sensing traces should be routed to the inductor pads so they only pick up the inductor DCR voltage. Each ISEN pin sees the average voltage of two sources: its own, phase inductor phase-node pad and the other phase inductor output side pad. [Equations 8](#) and [9](#) give the ISEN pin voltages:

$$V_{ISEN1} = V_{1p} + V_{2n} \quad (\text{EQ. 8})$$

$$V_{ISEN2} = V_{1n} + V_{2p} \quad (\text{EQ. 9})$$

The ISL62771 will make  $V_{ISEN1} = V_{ISEN2}$  as shown in [Equation 10](#):

$$V_{1p} + V_{2n} = V_{1n} + V_{2p} \quad (\text{EQ. 10})$$

Rewriting [Equation 10](#) gives [Equation 11](#):

$$V_{1p} - V_{1n} = V_{2p} - V_{2n} \quad (\text{EQ. 11})$$

Therefore:

$$R_{dcr1} \times I_{L1} = R_{dcr2} \times I_{L2} \quad (\text{EQ. 12})$$

Current balancing ( $I_{L1} = I_{L2}$ ) is achieved when  $R_{dcr1} = R_{dcr2}$ .  $R_{pcb1}$  and  $R_{pcb2}$  do not have any effect.

Since the slave ripple capacitor voltages mimic the inductor currents, the R3™ modulator can naturally achieve excellent current balancing during steady state and dynamic operations. [Figure 17](#) shows the current balancing performance of the evaluation board with load transient of 12A/51A at different rep rates. The inductor currents follow the load current dynamic change with the output capacitors supplying the difference. The inductor currents can track the load current well at a low repetition rate, but cannot keep up when the repetition rate gets into the hundred-kHz range, where it is out of the control loop bandwidth. The controller achieves excellent current balancing in all cases installed.

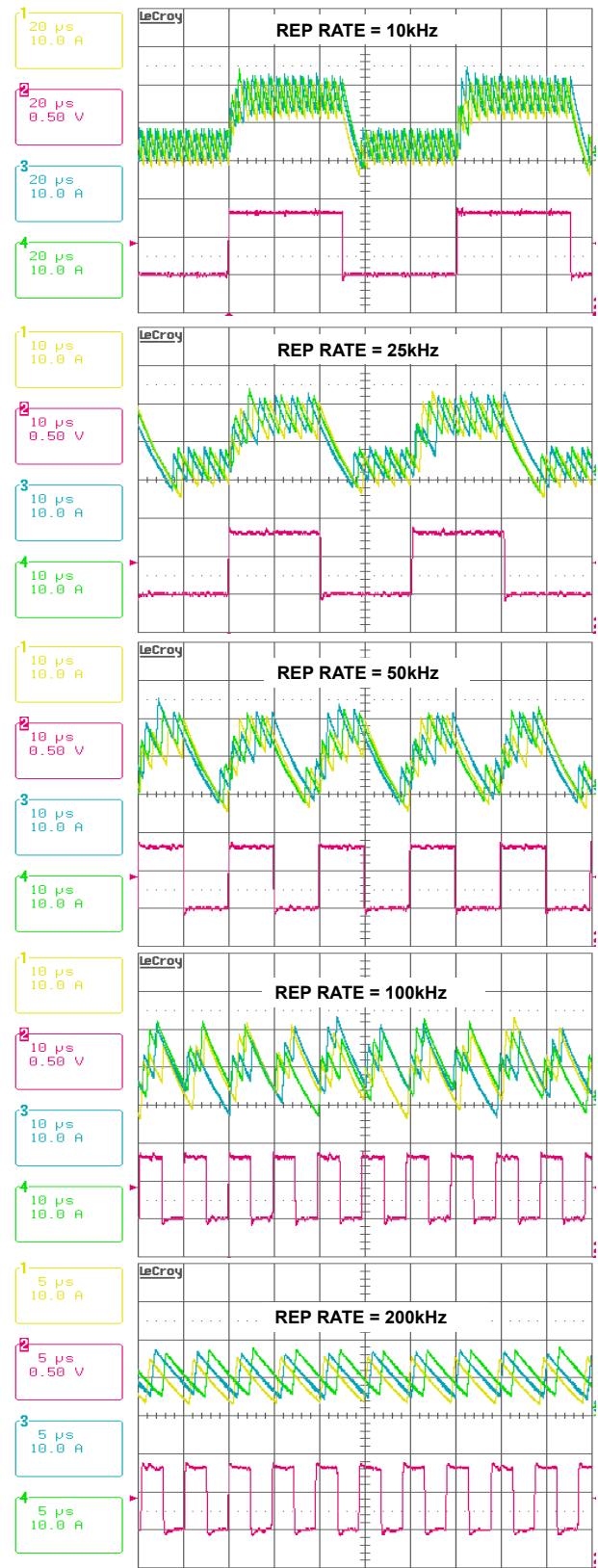

**FIGURE 17. CURRENT BALANCING DURING DYNAMIC OPERATION. CH1: I<sub>L1</sub>, CH2: I<sub>LOAD</sub>, CH3: I<sub>L2</sub>, CH4: I<sub>L3</sub>**

## Modes of Operation

TABLE 1. CORE VR MODES OF OPERATION

CONFIG.	ISEN2	PSLO_L AND PSI1_L	MODE	IMON OCP THRESHOLD (V)
2-phase Core VR Config.	To Power Stage	11	2-phase CCM	1.5
		01	1-phase DE	
		00	1-phase DE	
1-phase Core VR Config.	Tied to 5V	11	1-phase CCM	1.5
		01	1-phase DE	
		00	1-phase DE	

The Core VR can be configured for 2- or 1-phase operation.

[Table 1](#) shows Core VR configurations and operational modes, programmed by the ISEN2 pin status and the PSLO\_L & PSL1\_L commands via the SVI 2 interface, see [Table 8 on page 22](#).

For a 1-phase configuration, tie the ISEN2 pin to 5V. In this configuration, only Phase 1 is active.

For 2-phase configurations, the Core VR operates in 2-phase CCM with PSIO\_L and PSI\_L both high. If PSIO\_L is taken low via the SVI 2 interface, the Core VR sheds Phase 2 and the Core VR enters 1-phase DE mode. When both PSIO\_L and PSI1\_L are taken low, the Core VR continues to operate in the 1-phase DE mode.

In a 1-phase configuration, the Core VR operates in 1-phase CCM and enters 1-phase DE when PSIO\_L is taken low and continues to operate in this mode when both PSIO\_L and PSI1\_L are taken low.

The Core VR can be disabled completely by connecting ISEN1 to +5V.

ISL62771 Northbridge VR operates in 1-phase CCM.

[Table 2](#) shows the Northbridge VR operational modes, which are programmed by the PSIO\_L and PSI1\_L bits of the SVI 2 command.

TABLE 2. NORTHBRIDGE VR MODES OF OPERATION

CONFIG.	PSLO_L and PSI1_L	MODE	IMON OCP THRESHOLD
1-phase NB VR Config.	11	1-phase CCM	1.5V
	01	1-phase DE	
	00	1-phase DE	

The Northbridge VR operates in 1-phase CCM and enters 1-phase DE when PSIO\_L goes low and remains in this mode of operation when both PSIO\_L and PSI1\_L are low.

The Core and Northbridge VRs have an overcurrent threshold of 1.5V on IMON and IMON\_NB respectively and this level does not vary based on channel configuration. See [“Overcurrent” on page 23](#) for more details.

## Dynamic Operation

Core VR and Northbridge VR behave the same during dynamic operation. The controller responds to VID-on-the-fly changes by slewing to the new voltage at a fixed slew rate. During negative

VID transitions, the output voltage decays to the lower VID value at the slew rate determined by the load.

The R3™ modulator intrinsically has voltage feed-forward. The output voltage is insensitive to a fast slew rate input voltage change.

## Adaptive Body Diode Conduction Time Reduction

In DCM, the controller turns off the low-side MOSFET when the inductor current approaches zero. During on-time of the low-side MOSFET, phase voltage is negative and the amount is the MOSFET  $r_{DS(ON)}$  voltage drop, which is proportional to the inductor current. A phase comparator inside the controller monitors the phase voltage during on-time of the low-side MOSFET and compares it with a threshold to determine the zero crossing point of the inductor current. If the inductor current has not reached zero when the low-side MOSFET turns off, it will flow through the low-side MOSFET body diode, causing the phase node to have a larger voltage drop until it decays to zero. If the inductor current has crossed zero and reversed the direction when the low-side MOSFET turns off, it will flow through the high-side MOSFET body diode, causing the phase node to have a spike until it decays to zero. The controller continues monitoring the phase voltage after turning off the low-side MOSFET. To minimize the body diode-related loss, the controller also adjusts the phase comparator threshold voltage accordingly in iterative steps such that the low-side MOSFET body diode conducts for approximately 40ns.

## Resistor Configuration Options

The ISL62771 uses the COMP and COMP\_NB pins to configure some functionality within the IC. Resistors from these pins to GND are read during the first portion of the soft-start sequence. The following sections outline how to select the resistor values for each of these pins to correctly program the output voltage offset of each output and switching frequency used for both VRs.

## VR Offset Programming

A positive or negative offset is programmed for the Core VR using a resistor to ground from the COMP pin and the Northbridge in a similar manner from the COMP\_NB pin. [Table 3](#) provides the resistor value to select the desired output voltage offset. The 1% tolerance resistor value shown in the table must be used to program the corresponding Core or NB output voltage offset. The MIN and MAX tolerance values provide margin to insure the 1% tolerance resistor will be read correctly.

**TABLE 3. COMP AND COMP\_NB OUTPUT VOLTAGE OFFSET SELECTION**

RESISTOR VALUE [kΩ]			COMP V <sub>CORE</sub> OFFSET [mV]	COMP_NB OFFSET [mV]
MIN TOLERANCE	1% TOLERANCE VALUE	MAX TOLERANCE		
5.54	5.62	5.70	-43.75	18.75
7.76	7.87	7.98	-37.5	31.25
11.33	11.5	11.67	-31.25	43.76
16.65	16.9	17.15	-25	50
19.3	19.6	19.89	-18.75	37.5
24.53	24.9	25.27	-12.5	25
33.49	34.0	34.51	-6.25	12.5
40.58	41.2	41.81	6.25	0
51.52	52.3	53.08	18.75	18.75
72.10	73.2	74.29	31.25	31.25
93.87	95.3	96.72	43.76	43.76
119.19	121	112.81	50	50
151.69	154	156.31	37.5	37.5
179.27	182	184.73	25	25
206.85	210	213.15	12.5	12.5
	OPEN		0	0

## CCM Switching Frequency

The Core and Northbridge VR switching frequency is set by the programming resistor on COMP\_NB. When the ISL62771 is in continuous conduction mode (CCM), the switching frequency is not absolutely constant due to the nature of the R3™ modulator. As explained in the “[Multiphase R3™ Modulator](#)” on page 13, the effective switching frequency increases during load insertion and decreases during load release to achieve fast response. Thus, the switching frequency is relatively constant at steady state. Variation is expected when the power stage condition, such as input voltage, output voltage, load, etc. changes. The variation is usually less than 10% and does not have any significant effect on output voltage ripple magnitude. [Table 4](#) defines the switching frequency based on the resistor value used to program the COMP\_NB pin. Use the previous table related to COMP\_NB to determine the correct resistor value in these ranges to program the desired output offset and switching frequency configuration.

**TABLE 4. SWITCHING FREQUENCY SELECTION**

FREQUENCY [kHz]	COMP_NB RANGE [kΩ]
300	57.6 to OPEN
400	5.62 to 41.2

The controller monitors SVI commands to determine when to enter power-saving mode, implement dynamic VID changes and shut down individual outputs.

## AMD Serial VID Interface 2.0

The on-board Serial VID Interface 2.0 (SVI 2) circuitry allows the AMD processor to directly control the Core and Northbridge voltage reference levels within the ISL62771. Once the PWROK signal goes high, the IC begins monitoring the SVC and SVD pins for instructions. The ISL62771 uses a digital-to-analog converter (DAC) to generate a reference voltage based on the decoded SVI value. See [Figure 12](#) for a simple SVI interface timing diagram.

### Pre-PWROK Metal VID

Typical motherboard start-up begins with the controller decoding the SVC and SVD inputs to determine the pre-PWROK Metal VID setting (see [Table 5](#)). Once the ENABLE input exceeds the rising threshold, the ISL62771 decodes and locks the decoded value into an on-board hold register.

**TABLE 5. PRE-PWROK METAL VID CODES**

SVC	SVD	OUTPUT VOLTAGE (V)
0	0	1.1
0	1	1.0
1	0	0.9
1	1	0.8

The internal DAC circuitry begins to ramp Core and Northbridge VRs to the decoded pre-PWROK Metal VID output level. The digital soft-start circuitry ramps the internal reference to the target gradually at a fixed rate of 10mV/μs. The controlled ramp of all output voltage planes reduces in-rush current during the soft-start interval. At the end of the soft-start interval, the PGOOD and PGOOD\_NB outputs transition high, indicating both output planes are within regulation limits.

If the ENABLE input falls below the enable falling threshold, the ISL62771 tri-states both outputs. PGOOD and PGOOD\_NB are pulled low with the loss of ENABLE. The Core and Northbridge VR output voltages decay, based on output capacitance and load leakage resistance. If bias to VDD falls below the POR level, the ISL62771 responds in the manner previously described. Once VDD and ENABLE rise above their respective rising thresholds, the internal DAC circuitry reacquires a pre-PWROK metal VID code and the controller soft-starts.

### SVI Interface Active

Once the Core and Northbridge VRs have successfully soft-started and PGOOD and PGOOD\_NB signals transition high, PWROK can be asserted externally to the ISL62771. Once PWROK is asserted to the IC, SVI instructions can begin as the controller actively monitors the SVI interface. Details of the SVI Bus protocol are provided in the “AMD Serial VID Interface 2.0 (SVI2) Specification”. See AMD publication #48022.

Once a VID change command is received, the ISL62771 decodes the information to determine which VR is affected and the VID target is determined by the byte combinations in [Table 6](#). The internal DAC circuitry steps the output voltage of the VR commanded to the new VID level. During this time, one or more of the VR outputs could be targeted. In the event either VR is

# ISL62771

commanded to power-off by serial VID commands, the PGOOD signal remains asserted.

If the PWROK input is deasserted, then the controller steps both the Core and the Northbridge VRs back to the stored pre-PWROK metal VID level in the holding register from initial soft-start. No attempt is made to read the SVC and SVD inputs during this time. If PWROK is reasserted, then the ISL62771 SVI interface waits for instructions.

If ENABLE goes low during normal operation, all external MOSFETs are tri-stated and both PGOOD and PGOOD\_NB are pulled low. This event clears the pre-PWROK metal VID code and forces the controller to check SVC and SVD upon restart, storing the pre-PWROK metal VID code found on restart.

A POR event on VCC during normal operation shuts down both regulators and both PGOOD outputs are pulled low. The pre-PWROK metal VID code is not retained. Loss of VIN during operation will typically cause the controller to enter a fault condition on one or both outputs. The controller will shut down both Core and Northbridge VRs and latch off. The pre-PWROK metal VID code is not retained during the process of cycling ENABLE to reset the fault latch and restart the controller.

## VID-on-the-Fly Transition

Once PWROK is high, the ISL62771 detects this flag and begins monitoring the SVC and SVD pins for SVI instructions. The microprocessor follows the protocol outlined in the following sections to send instructions for VID-on-the-fly transitions. The ISL62771 decodes the instruction and acknowledges the new VID code. For VID codes higher than the current VID level, the ISL62771 begins stepping the commanded VR outputs to the

new VID target at the fixed slew rate of 10mV/μs. Once the DAC ramps to the new VID code, a VID-on-the-Fly Complete (VOTFC) request is sent on the SVI lines.

When the VID codes are lower than the current VID level, the ISL62771 checks the state of power state bits in the SVI command. If power state bits are not active, the controller begins stepping the regulator output to the new VID target. If the power state bits are active, the controller allows the output voltage to decay and slowly steps the DAC down with the natural decay of the output. This allows the controller to quickly recover and move to a high VID code if commanded. The controller issues a VOTFC request on the SVI lines once the SVI command is decoded and prior to reaching the final output voltage.

VOTFC requests do not take priority over telemetry per the AMD SVI 2 specification.

## SVI Data Communication Protocol

The SVI WIRE protocol is based on the I<sup>2</sup>C bus concept. Three wires [serial clock (SVC) and serial data (SVD) and telemetry (SVT)], carry information between the AMD processor (master) and VR controller (slave) on the bus. The master initiates and terminates SVI transactions and drives the clock, SVC, during a transaction. The AMD processor is always the master and the voltage regulators are the slaves. The slave receives the SVI transactions and acts accordingly. Mobile SVI WIRE protocol timing is based on high-speed mode I<sup>2</sup>C. See AMD publication #48022 for additional details.

TABLE 6. SERIAL VID CODES

SVID[7:0]	VOLTAGE (V)	SVID[7:0]	VOLTAGE (V)	SVID[7:0]	VOLTAGE (V)	SVID[7:0]	VOLTAGE (V)
0000_0000	1.55000	0010_0000	1.35000	0100_0000	1.15000	0110_0000	0.95000
0000_0001	1.54375	0010_0001	1.34375	0100_0001	1.14375	0110_0001	0.94375
0000_0010	1.53750	0010_0010	1.33750	0100_0010	1.13750	0110_0010	0.93750
0000_0011	1.53125	0010_0011	1.33125	0100_0011	1.13125	0110_0011	0.93125
0000_0100	1.52500	0010_0100	1.32500	0100_0100	1.12500	0110_0100	0.92500
0000_0101	1.51875	0010_0101	1.31875	0100_0101	1.11875	0110_0101	0.91875
0000_0110	1.51250	0010_0110	1.31250	0100_0110	1.11250	0110_0110	0.91250
0000_0111	1.50625	0010_0111	1.30625	0100_0111	1.10625	0110_0111	0.90625
0000_1000	1.50000	0010_1000	1.30000	0100_1000	1.10000	0110_1000	0.90000
0000_1001	1.49375	0010_1001	1.29375	0100_1001	1.09375	0110_1001	0.89375
0000_1010	1.48750	0010_1010	1.28750	0100_1010	1.08750	0110_1010	0.88750
0000_1011	1.48125	0010_1011	1.28125	0100_1011	1.08125	0110_1011	0.88125
0000_1100	1.47500	0010_1100	1.27500	0100_1100	1.07500	0110_1100	0.87500
0000_1101	1.46875	0010_1101	1.26875	0100_1101	1.06875	0110_1101	0.86875
0000_1110	1.46250	0010_1110	1.26250	0100_1110	1.06250	0110_1110	0.86250
0000_1111	1.45625	0010_1111	1.25625	0100_1111	1.05625	0110_1111	0.85625
0001_0000	1.45000	0011_0000	1.25000	0101_0000	1.05000	0111_0000	0.85000
0001_0001	1.44375	0011_0001	1.24375	0101_0001	1.04375	0111_0001	0.84375
0001_0010	1.43750	0011_0010	1.23750	0101_0010	1.03750	0111_0010	0.83750
0001_0011	1.43125	0011_0011	1.23125	0101_0011	1.03125	0111_0011	0.83125

# ISL62771

TABLE 6. SERIAL VID CODES (Continued)

SVID[7:0]	VOLTAGE (V)	SVID[7:0]	VOLTAGE (V)	SVID[7:0]	VOLTAGE (V)	SVID[7:0]	VOLTAGE (V)
0001_0100	1.42500	0011_0100	1.22500	0101_0100	1.02500	0111_0100	0.82500
0001_0101	1.41875	0011_0101	1.21875	0101_0101	1.01875	0111_0101	0.81875
0001_0110	1.41250	0011_0110	1.21250	0101_0110	1.01250	0111_0110	0.81250
0001_0111	1.40625	0011_0111	1.20625	0101_0111	1.00625	0111_0111	0.80625
0001_1000	1.40000	0011_1000	1.20000	0101_1000	1.00000	0111_1000	0.80000
0001_1001	1.39375	0011_1001	1.19375	0101_1001	0.99375	0111_1001	0.79375
0001_1010	1.38750	0011_1010	1.18750	0101_1010	0.98750	0111_1010	0.78750
0001_1011	1.38125	0011_1011	1.18125	0101_1011	0.98125	0111_1011	0.78125
0001_1100	1.37500	0011_1100	1.17500	0101_1100	0.97500	0111_1100	0.77500
0001_1101	1.36875	0011_1101	1.16875	0101_1101	0.96875	0111_1101	0.76875
0001_1110	1.36250	0011_1110	1.16250	0101_1110	0.96250	0111_1110	0.76250
0001_1111	1.35625	0011_1111	1.15625	0101_1111	0.95625	0111_1111	0.75625
1000_0000	0.75000	1010_0000	0.55000*	1100_0000	0.35000*	1110_0000	0.15000*
1000_0001	0.74375	1010_0001	0.54375*	1100_0001	0.34375*	1110_0001	0.14375*
1000_0010	0.73750	1010_0010	0.53750*	1100_0010	0.33750*	1110_0010	0.13750*
1000_0011	0.73125	1010_0011	0.53125*	1100_0011	0.33125*	1110_0011	0.13125*
1000_0100	0.72500	1010_0100	0.52500*	1100_0100	0.32500*	1110_0100	0.12500*
1000_0101	0.71875	1010_0101	0.51875*	1100_0101	0.31875*	1110_0101	0.11875*
1000_0110	0.71250	1010_0110	0.51250*	1100_0110	0.31250*	1110_0110	0.11250*
1000_0111	0.70625	1010_0111	0.50625*	1100_0111	0.30625*	1110_0111	0.10625*
1000_1000	0.70000	1010_1000	0.50000*	1100_1000	0.30000*	1110_1000	0.10000*
1000_1001	0.69375	1010_1001	0.49375*	1100_1001	0.29375*	1110_1001	0.09375*
1000_1010	0.68750	1010_1010	0.48750*	1100_1010	0.28750*	1110_1010	0.08750*
1000_1011	0.68125	1010_1011	0.48125*	1100_1011	0.28125*	1110_1011	0.08125*
1000_1100	0.67500	1010_1100	0.47500*	1100_1100	0.27500*	1110_1100	0.07500*
1000_1101	0.66875	1010_1101	0.46875*	1100_1101	0.26875*	1110_1101	0.06875*
1000_1110	0.66250	1010_1110	0.46250*	1100_1110	0.26250*	1110_1110	0.06250*
1000_1111	0.65625	1010_1111	0.45625*	1100_1111	0.25625*	1110_1111	0.05625*
1001_0000	0.65000	1011_0000	0.45000*	1101_0000	0.25000*	1111_0000	0.05000*
1001_0001	0.64375	1011_0001	0.44375*	1101_0001	0.24375*	1111_0001	0.04375*
1001_0010	0.63750	1011_0010	0.43750*	1101_0010	0.23750*	1111_0010	0.03750*
1001_0011	0.63125	1011_0011	0.43125*	1101_0011	0.23125*	1111_0011	0.03125*
1001_0100	0.62500	1011_0100	0.42500*	1101_0100	0.22500*	1111_0100	0.02500*
1001_0101	0.61875	1011_0101	0.41875*	1101_0101	0.21875*	1111_0101	0.01875*
1001_0110	0.61250	1011_0110	0.41250*	1101_0110	0.21250*	1111_0110	0.01250*
1001_0111	0.60625	1011_0111	0.40625*	1101_0111*	0.20625*	1111_0111	0.00625*
1001_1000	0.60000*	1011_1000	0.40000*	1101_1000	0.20000*	1111_1000	OFF*
1001_1001	0.59375*	1011_1001	0.39375*	1101_1001	0.19375*	1111_1001	OFF*
1001_1010	0.58750*	1011_1010	0.38750*	1101_1010	0.18750*	1111_1010	OFF*
1001_1011	0.58125*	1011_1011	0.38125*	1101_1011	0.18125*	1111_1011	OFF*
1001_1100	0.57500*	1011_1100	0.37500*	1101_1100	0.17500*	1111_1100	OFF*
1001_1101	0.56875*	1011_1101	0.36875*	1101_1101	0.16875*	1111_1101	OFF*
1001_1110	0.56250*	1011_1110	0.36250*	1101_1110	0.16250*	1111_1110	OFF*
1001_1111	0.55625*	1011_1111	0.35625*	1101_1111	0.15625*	1111_1111	OFF*

NOTE: \*Indicates a VID not required for AMD Family 10h processors. Loosened AMD requirements at these levels.

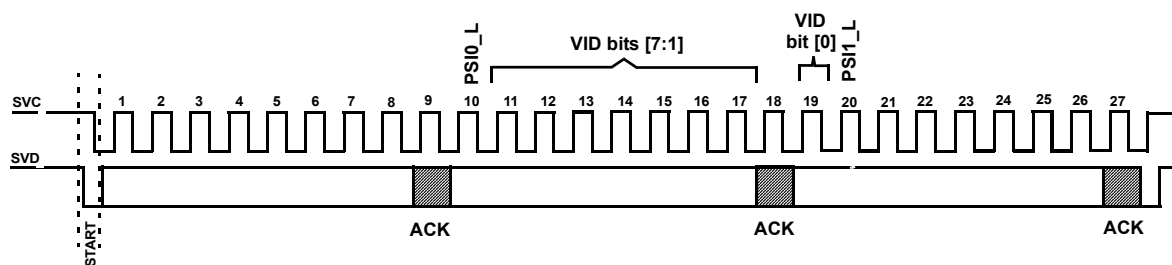

FIGURE 18. SVD PACKET STRUCTURE

## SVI Bus Protocol

The AMD processor bus protocol is compliant with SMBus send byte protocol for VID transactions. The AMD SVD packet structure is shown in [Figure 18](#). The description of what each bit of the three bytes that make up the SVI command are shown in [Table 7](#). During a transaction, the processor sends the start sequence followed by each of the three bytes, which end with an optional acknowledge bit. The ISL62771 does not drive the SVD line during the ACK bit. Finally, the processor sends the stop sequence. After the ISL62771 has detected the stop, it can then proceed with the commanded action from the transaction.

TABLE 7. SVD DATA PACKET

BITS	DESCRIPTION
1:5	Always 11000b
6	Core domain selector bit, if set then the following data byte contains VID, power state, telemetry control, load line trim and offset trim apply to the Core VR.
7	Northbridge domain selector bit, if set then the following data byte contains VID, power state, telemetry control, load line trim and offset trim apply to the Northbridge VR.
8	Always 0b
9	Acknowledge Bit
10	PSIO_L
11:17	VID Code bits [7:1]
18	Acknowledge Bit
19	VID Code bit [0]
20	PSI1_L
21	TFN (Telemetry Functionality)
22:24	Load Line Slope Trim
25:26	Offset Trim [1:0]
27	Acknowledge Bit

## Power States

SVI2 defines two power state indicator levels, see [Table 8](#). As processor current consumption reduces the power state indicator level changes to improve VR efficiency under low power conditions.

For the Core VR operating in 2-phase mode, when PSIO\_L is asserted, Channel 2 is tri-stated and Channel 1 enters diode emulation mode to boost efficiency. When PSIO\_L and PSI1\_L are asserted low, the Core VR continues to operate in this mode.

For the 1-Phase Northbridge VR, when PSIO\_L is asserted, Channel 1 enters diode emulation mode to boost efficiency. When PSIO\_L and PSI1\_L are asserted low, the Northbridge VR continues to operate in this fashion.

It is possible for the processor to assert or deassert PSIO\_L and PSI1\_L out of order. PSIO\_L takes priority over PSI1\_L. If PSIO\_L is deasserted while PSI1\_L is still asserted, the ISL62771 will return the selected VR back full channel CCM operation.

TABLE 8. PSIO\_L, PSI1\_L AND TFN DEFINITION

FUNCTION	BIT	DESCRIPTION
PSIO_L	10	Power State Indicate level 0. When this signal is asserted (active Low) the processor is in a low enough power state for the VR controller to take action to boost efficiency by dropping phases and/or entering 1-Phase DE.
PSI1_L	20	Power State Indicate level 1. When this signal is asserted (active Low) the processor is in a low enough power state for the VR controller to take action to boost efficiency by dropping phases and entering 1-Phase DE.
TFN	21	Telemetry Functionality. This is an active high signal that allows the processor to control the telemetry functionality of the VR.

## Dynamic Load Line Slope Trim

The ISL62771 supports the SVI2 ability for the processor to manipulate the load line slope of the Core and Northbridge VRs independently using the serial VID interface. The slope manipulation applies to the initial load line slope. A load line slope trim will typically coincide with a VOTF change. See [Table 9](#) for more information about the load line slope trim feature of the ISL62771.

TABLE 9. LOAD LINE SLOPE TRIM DEFINITION

LOAD LINE SLOPE TRIM [2:0]	DESCRIPTION
000	Disable LL
001	-40% mΩ Change
010	-20% mΩ Change
011	No Change
100	+20% mΩ Change
101	+40% mΩ Change
110	+60% mΩ Change
111	+80% mΩ Change



## Dynamic Offset Trim

The ISL62771 supports the SVI2 ability for the processor to manipulate the output voltage offset of the Core and Northbridge VRs. This offset is in addition to any output voltage offset set via the COMP resistor reader. The dynamic offset trim can disable the COMP resistor programmed offset of either output when “Disable All Offset” is selected.

TABLE 10. OFFSET TRIM DEFINITION

OFFSET TRIM [1:0]	DESCRIPTION
00	Disable All Offset
01	-25mV Change
10	0mV Change
11	+25mV Change

## Telemetry

The ISL62771 can provide voltage and current information through the telemetry system outlined by the AMD SVI2 specification. The telemetry data is transmitted through the SVC and SVT lines of the SVI 2 interface.

Current telemetry is based on a voltage generated across a 133kΩ resistor placed from the IMON pin to GND. The current flowing out of the IMON pin is proportional to the load current in the VR. The  $I_{sum}$  current defined in the [“Voltage Regulation and Load Line Implementation” on page 15](#) provides the base conversion from the load current to the internal amplifier created  $I_{sum}$  current. The  $I_{sum}$  current is then divided down by a factor of 4 to create the IMON current, which flows out of the IMON pin. The  $I_{sum}$  current will measure 35μA when the load current is at full load based on a droop current designed for 45μA at the same load current. The difference between the  $I_{sum}$  current and the droop current is provided in [Equation 2](#). The IMON current will measure 11.25μA at full load current for the VR and the IMON voltage will be 1.2V. The load percentage, which is reported by the IC is based on this voltage. When the load is 25% of the full load, the voltage on the IMON pin will be 25% of 1.2V or 0.3V.

The SVI interface allows the selection of no telemetry, voltage only, or voltage and current telemetry on either or both of the VR outputs. The TFN bit along with the Core and Northbridge domain selector bits are used by the processor to change the functionality of telemetry, see [Table 11](#) for more information.

TABLE 11. TFN TRUTH TABLE

TFN, CORE, NB BITS [21,6,7]	DESCRIPTION
1,0,1	Telemetry is in voltage and current mode. Therefore, voltage and current are sent for VDD and VDDNB domains by the controller.
1,0,0	Telemetry is in voltage mode only. Only the voltage of VDD and VDDNB domains is sent by the controller.
1,1,0	Telemetry is disabled.
1,1,1	Reserved

## Protection Features

Core VR and Northbridge VR both provide overcurrent, current-balance, undervoltage and overvoltage fault protections. The controller also provides over-temperature protection. The following discussion is based on Core VR and also applies to the Northbridge VR.

### Overcurrent

The IMON voltage provides a means of determining the load current at any moment in time. The overcurrent protection (OCP) circuitry monitors the IMON voltage to determine when a fault occurs. Based on the previous description in the [“Voltage Regulation and Load Line Implementation” on page 15](#), the current, which flows out of the IMON pin, is proportional to the ISUM current. The ISUM current is created from the sensed voltage across  $C_n$ , which is a measure of the load current based upon the sensing element selected. The IMON current is generated internally and is 1/4 of the ISUM current. The EDC or  $IDD_{spike}$  current value for the AMD CPU load is used to set the maximum current level for droop and the IMON voltage of 1.2V, which indicates 100% loading for telemetry. The ISUM current level at maximum load, or  $IDD_{spike}$  is 36μA and this translates to an IMON current level of 9μA. The IMON resistor is 133kΩ and the 9μA flowing through the IMON resistor results in a 1.2V level at maximum loading of the VR.

The overcurrent threshold is 1.5V on the IMON pin. Based on a 1.2V IMON voltage equating to 100% loading, the additional 0.3V provided above this level equates to a 25% increase in load current before an OCP fault is detected. The EDC or  $IDD_{spike}$  current is used to set the 1.2V on IMON for full load current. So the OCP level is 1.25x the EDC or  $IDD_{spike}$  current level. This additional margin above the EDC or  $IDD_{spike}$  current allows the AMD CPU to enter and exit the  $IDD_{spike}$  performance mode without issue unless the load current is out of line with the  $IDD_{spike}$  expectation, thus the need for overcurrent protection.

When the voltage on the IMON pin meets the overcurrent threshold of 1.5V, this triggers an OCP event. Within 2μs of detecting an OCP event, the controller asserts VR\_HOT\_L low to communicate to the AMD CPU to throttle back. A fault timer begins counting while IMON is at or above the 1.5V threshold. The fault timer lasts 7.5μs to 11μs and then flags an OCP fault. The controller then tri-states the active channels and goes into shutdown. PGOOD is taken low and a fault flag from this VR is sent to the other VR and it is shutdown within 10μs. If the IMON voltage drops below the 1.5V threshold prior to the fault timer count finishing, the fault timer is cleared and VR\_HOT\_L is taken high.

The ISL62771 also features a way-overcurrent [WOC] feature, which immediately takes the controller into shutdown. This protection is also referred to as fast overcurrent protection for short-circuit protection. If the IMON current reaches 15μA, WOC is triggered. Active channels are tri-stated and the controller is placed in shutdown and PGOOD is pulled low. There is no fault timer on the WOC fault, the controller takes immediate action. The other controller output is also shutdown within 10μs.

## Current-Balance

The controller monitors the ISENx pin voltages to determine current-balance protection. If the ISENx pin voltage difference is greater than 9mV for 1ms, the controller will declare a fault and latch off.

## Undervoltage

If the VSEN voltage falls below the output voltage VID value plus any programmed offsets by -325mV, the controller declares an undervoltage fault. The controller deasserts PGOOD and tri-states the power MOSFETs.

## Overvoltage

If the VSEN voltage exceeds the output voltage VID value plus any programmed offsets by +325mV, the controller declares an overvoltage fault. The controller deasserts PGOOD and turns on the low-side power MOSFETs. The low-side power MOSFETs remain on until the output voltage is pulled down below the VID set value. Once the output voltage is below this level, the lower gate is tri-stated. If the output voltage rises above the overvoltage threshold again, the protection process is repeated. When all power MOSFETs are turned off. This behavior provides the maximum amount of protection against shorted high-side power MOSFETs while preventing output ringing below ground.

## Thermal Monitor [NTC, NTC\_NB]

The ISL62771 features two thermal monitors, which use an external resistor network that includes an NTC thermistor to monitor motherboard temperature and alert the AMD CPU of a thermal issue. Figure 19 shows the basic thermal monitor circuit on the Core VR NTC pin. The Northbridge VR features the same thermal monitor. The controller drives a 30µA current out of the NTC pin and monitors the voltage at the pin. The current flowing out of the NTC pin creates a voltage that is compared to a warning threshold of 640mV. When the voltage at the NTC pin falls to this warning threshold or below, the controller asserts VR\_HOT\_L to alert the AMD CPU to throttle back load current to stabilize the motherboard temperature. A thermal fault counter begins counting toward a minimum shutdown time of 100µs. The thermal fault counter is an up/down counter, so if the voltage at the NTC pin rises above the warning threshold, it will count down and extend the time for a thermal fault to occur. The warning threshold does have 20mV of hysteresis.

If the voltage at the NTC pin continues to fall down to the shutdown threshold of 580mV or below, the controller goes into shutdown and triggers a thermal fault. The PGOOD pin is pulled low and tri-states the power MOSFETs. A fault on either side will shutdown both VRs.

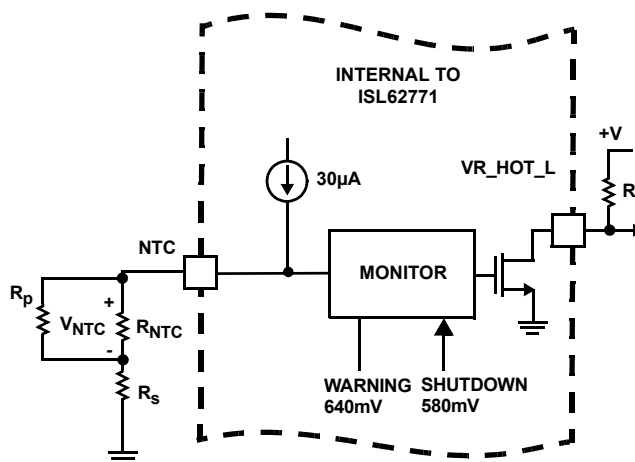

**FIGURE 19. CIRCUITRY ASSOCIATED WITH THE THERMAL MONITOR FEATURE OF THE ISL62771**

As the board temperature rises, the NTC thermistor resistance decreases and the voltage at the NTC pin drops. When the voltage on the NTC pin drops below the over-temperature trip threshold, then VR\_HOT is pulled low. The VR\_HOT signal is used to change the CPU operation and decrease power consumption. With the reduction in power consumption by the CPU, the board temperature decreases and the NTC thermistor voltage rises. Once the over-temperature threshold is tripped and VR\_HOT is taken low, the over-temperature threshold changes to the reset level. The addition of hysteresis to the over-temperature threshold prevents nuisance trips. Once both pin voltages exceed the over-temperature reset threshold, the pull-down on VR\_HOT is released. The signal changes state and the CPU resumes normal operation. The over-temperature threshold returns to the trip level.

Table 12 summarizes the fault protections.

**TABLE 12. FAULT PROTECTION SUMMARY**

FAULT TYPE	FAULT DURATION BEFORE PROTECTION	PROTECTION ACTION	FAULT RESET
Overcurrent	7.5µs to 11.5µs	PWM tri-state, PGOOD latched low	ENABLE toggle or VDD toggle
Phase Current Unbalance	1ms		
Way-Overcurrent (1.5xOC)	Immediately		
Undervoltage -325mV		PGOOD latched low. PWM tri-state.	
Overvoltage +325mV		PGOOD latched low. Actively pulls the output voltage to below VID value, then tri-state.	
NTC Thermal	100µs min	PGOOD latched low. PWM tri-state.	



## Fault Recovery

All of the previously described fault conditions can be reset by bringing ENABLE low or by bringing VDD below the POR threshold. When ENABLE and VDD return to their high operating levels, the controller resets the faults and soft-start occurs.

## Interface Pin Protection

The SVC and SVD pins feature protection diodes, which must be considered when removing power to VDD and VDDIO, but leaving it applied to these pins. Figure 20 shows the basic protection on the pins. If SVC and/or SVD are powered but VDD is not, leakage current will flow from these pins to VDD.

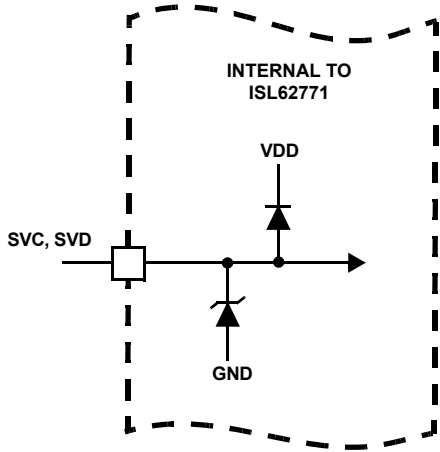

FIGURE 20. PROTECTION DEVICES ON THE SVC AND SVD PINS

## Key Component Selection

### Inductor DCR Current-Sensing Network

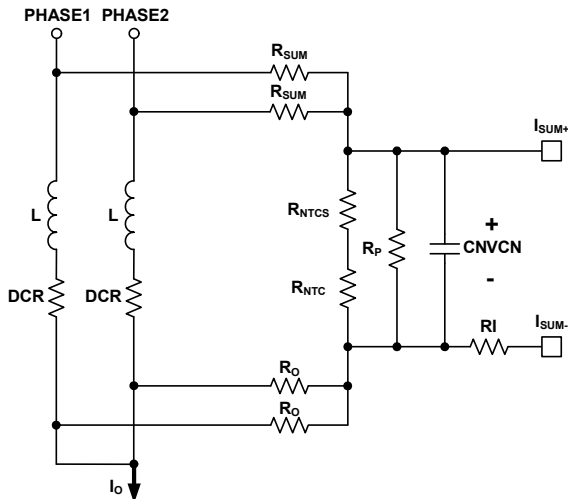

FIGURE 21. DCR CURRENT-SENSING NETWORK

Figure 21 shows the inductor DCR current-sensing network for a 2-phase solution. An inductor current flows through the DCR and creates a voltage drop. Each inductor has two resistors in  $R_{SUM}$  and  $R_O$  connected to the pads to accurately sense the inductor current by sensing the DCR voltage drop. The  $R_{SUM}$  and  $R_O$  resistors are connected in a summing network as shown and feed the total current information to the NTC network (consisting of  $R_{NTCS}$ ,  $R_{NTC}$  and  $R_P$ ) and capacitor  $C_N$ .  $R_{NTC}$  is a negative temperature coefficient (NTC) thermistor, used to temperature compensate the inductor DCR change.

The inductor output side pads are electrically shorted in the schematic but have some parasitic impedance in actual board layout, which is why one cannot simply short them together for the current-sensing summing network. It is recommended to use  $1\Omega$ – $10\Omega$   $R_O$  to create quality signals. Since  $R_O$  value is much smaller than the rest of the current sensing circuit, the following analysis ignores it.

The summed inductor current information is presented to the capacitor  $C_N$ . Equations 13 through 17 describe the frequency domain relationship between inductor total current  $I_o(s)$  and  $C_N$  voltage  $V_{Cn}(s)$ :

$$V_{Cn}(s) = \left( \frac{R_{ntcnet}}{R_{ntcnet} + \frac{N}{R_{sum}}} \times \frac{DCR}{N} \right) \times I_o(s) \times A_{cs}(s) \quad (EQ. 13)$$

$$R_{ntcnet} = \frac{(R_{ntcs} + R_{ntc}) \times R_p}{R_{ntcs} + R_{ntc} + R_p} \quad (EQ. 14)$$

$$A_{cs}(s) = \frac{1 + \frac{s}{\omega_L}}{1 + \frac{s}{\omega_{sns}}} \quad (EQ. 15)$$

$$\omega_L = \frac{DCR}{L} \quad (EQ. 16)$$

$$\omega_{sns} = \frac{1}{\frac{R_{ntcnet} \times \frac{R_{sum}}{N}}{R_{ntcnet} + \frac{R_{sum}}{N}} \times C_n} \quad (EQ. 17)$$

Where  $N$  is the number of phases.

Transfer function  $A_{cs}(s)$  always has unity gain at DC. The inductor DCR value increases as the winding temperature increases, giving higher reading of the inductor DC current. The NTC  $R_{ntc}$  value decrease as its temperature decreases. Proper selection of  $R_{SUM}$ ,  $R_{ntcs}$ ,  $R_p$  and  $R_{ntc}$  parameters ensures that  $V_{Cn}$  represents the inductor total DC current over the temperature range of interest.

There are many sets of parameters that can properly temperature-compensate the DCR change. Since the NTC network and the  $R_{SUM}$  resistors form a voltage divider,  $V_{Cn}$  is always a fraction of the inductor DCR voltage. It is recommended to have a higher ratio of  $V_{Cn}$  to the inductor DCR voltage so the droop circuit has a higher signal level to work with.

A typical set of parameters that provide good temperature compensation are:  $R_{SUM} = 3.65k\Omega$ ,  $R_p = 11k\Omega$ ,  $R_{ntcs} = 2.61k\Omega$  and  $R_{ntc} = 10k\Omega$  (ERT-J1VR103J). The NTC network parameters

may need to be fine-tuned on actual boards. One can apply full load DC current and record the output voltage reading immediately; then record the output voltage reading again when the board has reached the thermal steady state. A good NTC network can limit the output voltage drift to within 2mV. It is recommended to follow the Intersil evaluation board layout and current sensing network parameters to minimize engineering time.

$V_{Cn}(s)$  also needs to represent real-time  $I_o(s)$  for the controller to achieve good transient response. Transfer function  $A_{CS}(s)$  has a pole  $\omega_{SNS}$  and a zero  $\omega_L$ . One needs to match  $\omega_L$  and  $\omega_{SNS}$  so  $A_{CS}(s)$  is unity gain at all frequencies. By forcing  $\omega_L$  equal to  $\omega_{SNS}$  and solving for the solution, [Equation 18](#) gives  $C_n$  value.

$$C_n = \frac{L}{\frac{R_{ntcnet} \times \frac{R_{sum}}{N}}{R_{ntcnet} + \frac{R_{sum}}{N}} \times DCR} \quad (EQ. 18)$$

For example, given  $N = 2$ ,  $R_{sum} = 3.65k\Omega$ ,  $R_p = 11k\Omega$ ,  $R_{ntcs} = 2.61k\Omega$ ,  $R_{ntc} = 10k\Omega$ ,  $DCR = 0.88m\Omega$  and  $L = 0.36\mu H$ , [Equation 18](#) gives  $C_n = 0.294\mu F$ .

Assuming the compensator design is correct, [Figure 22](#) shows the expected load transient response waveforms if  $C_n$  is correctly selected. When the load current  $I_{core}$  has a square change, the output voltage  $V_{core}$  also has a square response.

If  $C_n$  value is too large or too small,  $V_{Cn}(s)$  does not accurately represent real-time  $I_o(s)$  and worsens the transient response. [Figure 23](#) shows the load transient response when  $C_n$  is too small.  $V_{core}$  sags excessively upon load insertion and may create a system failure. [Figure 24](#) shows the transient response when  $C_n$  is too large.  $V_{core}$  is sluggish in drooping to its final value. There is excessive overshoot if load insertion occurs during this time, which may negatively affect the CPU reliability.

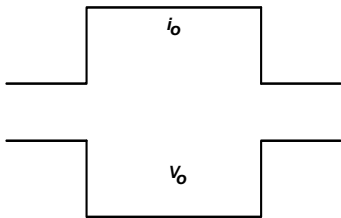

FIGURE 22. DESIRED LOAD TRANSIENT RESPONSE WAVEFORMS

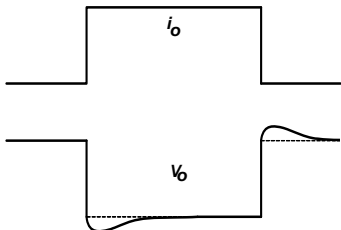

FIGURE 23. LOAD TRANSIENT RESPONSE WHEN  $C_n$  IS TOO SMALL

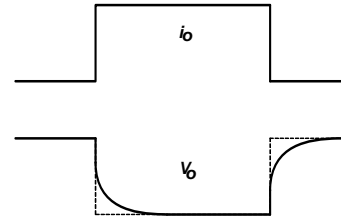

FIGURE 24. LOAD TRANSIENT RESPONSE WHEN  $C_n$  IS TOO LARGE

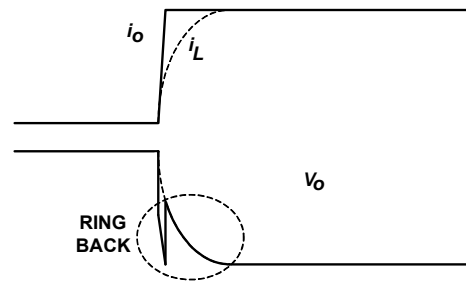

FIGURE 25. OUTPUT VOLTAGE RING-BACK PROBLEM

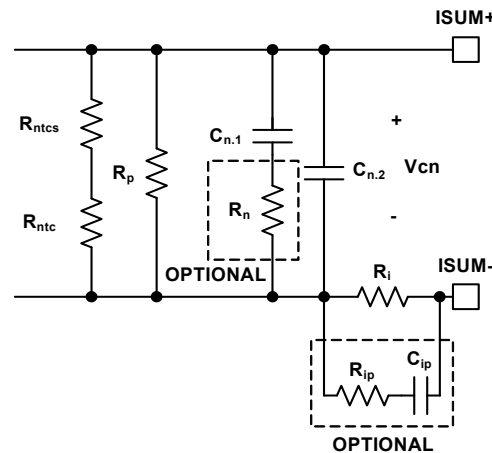

FIGURE 26. OPTIONAL CIRCUITS FOR RING-BACK REDUCTION

[Figure 25](#) shows the output voltage ring-back problem during load transient response. The load current  $i_o$  has a fast step change, but the inductor current  $i_L$  cannot accurately follow. Instead,  $i_L$  responds in first-order system fashion due to the nature of the current loop. The ESR and ESL effect of the output capacitors makes the output voltage  $V_o$  dip quickly upon load current change. However, the controller regulates  $V_o$  according to the droop current  $i_{droop}$ , which is a real-time representation of  $i_L$ ; therefore, it pulls  $V_o$  back to the level dictated by  $i_L$ , causing the ring-back problem. This phenomenon is not observed when the output capacitor has very low ESR and ESL, as is the case with all ceramic capacitors.

[Figure 26](#) shows two optional circuits for reduction of the ring-back.  $C_n$  is the capacitor used to match the inductor time constant. It usually takes the parallel of two (or more) capacitors to get the desired value. [Figure 26](#) shows that two capacitors ( $C_{n,1}$  and  $C_{n,2}$ ) are in parallel. Resistor  $R_n$  is an optional

component to reduce the  $V_o$  ring-back. At steady state,  $C_{n,1} + C_{n,2}$  provides the desired  $C_n$  capacitance. At the beginning of  $i_o$  change, the effective capacitance is less because  $R_n$  increases the impedance of the  $C_{n,1}$  branch. As [Figure 23](#) shows,  $V_o$  tends to dip when  $C_n$  is too small and this effect reduces the  $V_o$  ring-back. This effect is more pronounced when  $C_{n,1}$  is much larger than  $C_{n,2}$ . It is also more pronounced when  $R_n$  is bigger. However, the presence of  $R_n$  increases the ripple of the  $V_n$  signal if  $C_{n,2}$  is too small. It is recommended to keep  $C_{n,2}$  greater than 2200pF.  $R_n$  value usually is a few ohms.  $C_{n,1}$ ,  $C_{n,2}$  and  $R_n$  values should be determined through tuning the load transient response waveforms on an actual board.

$R_{ip}$  and  $C_{ip}$  form an R-C branch in parallel with  $R_i$ , providing a lower impedance path than  $R_i$  at the beginning of  $i_o$  change.  $R_{ip}$  and  $C_{ip}$  do not have any effect at steady state. Through proper selection of  $R_{ip}$  and  $C_{ip}$  values,  $i_{droop}$  can resemble  $i_o$  rather than  $i_L$  and  $V_o$  will not ring back. The recommended value for  $R_{ip}$  is 100Ω.  $C_{ip}$  should be determined through tuning the load transient response waveforms on an actual board. The recommended range for  $C_{ip}$  is 100pF~2000pF. However, it should be noted that the  $R_{ip}$ - $C_{ip}$  branch may distort the  $i_{droop}$  waveform. Instead of being triangular as the real inductor current,  $i_{droop}$  may have sharp spikes, which may adversely affect  $i_{droop}$  average value detection and therefore may affect OCP accuracy. User discretion is advised.

## Resistor Current-Sensing Network

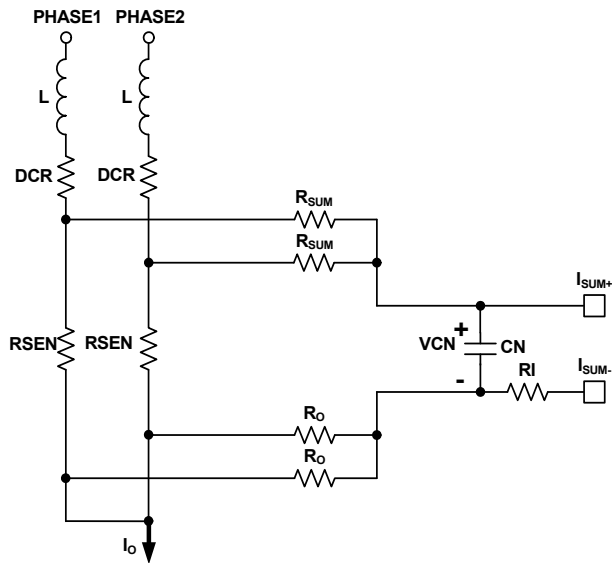

FIGURE 27. RESISTOR CURRENT-SENSING NETWORK

[Figure 27](#) shows the resistor current-sensing network for a 2-phase solution. Each inductor has a series current sensing resistor,  $R_{sen}$ .  $R_{sum}$  and  $R_o$  are connected to the  $R_{sen}$  pads to accurately capture the inductor current information. The  $R_{sum}$  and  $R_o$  resistors are connected to capacitor  $C_n$ .  $R_{sum}$  and  $C_n$  form a filter for noise attenuation. [Equations 19](#) through [21](#) give the  $V_{Cn}(s)$  expression.

$$V_{Cn}(s) = \frac{R_{sen}}{N} \times I_o(s) \times A_{Rsen}(s) \quad (EQ. 19)$$

$$A_{Rsen}(s) = \frac{1}{1 + \frac{s}{\omega_{Rsen}}} \quad (EQ. 20)$$

$$\omega_{Rsen} = \frac{1}{\frac{R_{sum}}{N} \times C_n} \quad (EQ. 21)$$

Transfer function  $A_{Rsen}(s)$  always has unity gain at DC. Current-sensing resistor  $R_{sen}$  value does not have significant variation over-temperature, so there is no need for the NTC network.

The recommended values are  $R_{sum} = 1k\Omega$  and  $C_n = 5600pF$ .

## Overcurrent Protection

Refer to [Equation 2](#) on [page 16](#) and [Figures 21, 25](#) and [27](#); resistor  $R_i$  sets the  $I_{sum}$  current, which is proportional to droop current and IMON current. [Tables 1](#) and [2](#) show the internal OCP threshold based on the IMON pin voltage. Since the  $R_i$  resistor impacts both the droop current and the IMON current, fine adjustments to  $I_{droop}$  will require changing the  $R_{comp}$  resistor.

For example, the OCP threshold is 1.5V on the IMON pin, which equates to an IMON current of 11.25μA using a 133kΩ IMON resistor. The corresponding ISUM current is 45μA, which results in an  $I_{droop}$  of 56.25μA. At full load current,  $I_{omax}$ , the ISUM current is 36μA and the resulting  $I_{droop}$  is 45μA. The ratio of the ISUM current at OCP relative to full load is 1.25. Therefore, the OCP current trip level is 25% higher than the full load current.

For inductor DCR sensing, [Equation 22](#) gives the DC relationship of  $V_{Cn}(s)$  and  $I_o(s)$ :

$$V_{Cn} = \left( \frac{R_{ntcnet}}{R_{ntcnet} + \frac{R_{sum}}{N}} \times \frac{DCR}{N} \right) \times I_o \quad (EQ. 22)$$

Substitution of [Equation 22](#) into [Equation 2](#) gives [Equation 23](#):

$$I_{droop} = \frac{5}{4} \times \frac{1}{R_i} \times \frac{R_{ntcnet}}{R_{ntcnet} + \frac{R_{sum}}{N}} \times \frac{DCR}{N} \times I_o \quad (EQ. 23)$$

Therefore:

$$R_i = \frac{5}{4} \times \frac{R_{ntcnet} \times DCR \times I_o}{N \times \left( R_{ntcnet} + \frac{R_{sum}}{N} \right) \times I_{droop}} \quad (EQ. 24)$$

Substitution of [Equation 14](#) and application of the OCP condition in [Equation 24](#) gives [Equation 25](#):

$$R_i = \frac{5}{4} \times \frac{\left( R_{ntcs} + R_{ntc} \right) \times R_p \times DCR \times I_{omax}}{N \times \left( \left( R_{ntcs} + R_{ntc} \right) \times R_p + \frac{R_{sum}}{N} \right) \times I_{droopmax}} \quad (EQ. 25)$$

Where  $I_{o\max}$  is the full load current and  $I_{\text{droopmax}}$  is the corresponding droop current. For example, given  $N = 2$ ,  $R_{\text{sum}} = 3.65\text{k}\Omega$ ,  $R_p = 1.1\text{k}\Omega$ ,  $R_{\text{ntcs}} = 2.61\text{k}\Omega$ ,  $R_{\text{ntc}} = 10\text{k}\Omega$ ,  $\text{DCR} = 0.88\text{m}\Omega$ ,  $I_{o\max} = 50\text{A}$  and  $I_{\text{droopmax}} = 45\mu\text{A}$ . Equation 25 gives  $R_i = 466\Omega$ .

For resistor sensing, Equation 26 gives the DC relationship of  $V_{\text{cn}}(s)$  and  $I_o(s)$ .

$$V_{\text{cn}} = \frac{R_{\text{sen}}}{N} \times I_o \quad (\text{EQ. 26})$$

Substitution of Equation 26 into Equation 2 gives Equation 27:

$$I_{\text{droop}} = \frac{5}{4} \times \frac{1}{R_i} \times \frac{R_{\text{sen}}}{N} \times I_o \quad (\text{EQ. 27})$$

Therefore:

$$R_i = \frac{5}{4} \times \frac{R_{\text{sen}} \times I_o}{N \times I_{\text{droop}}} \quad (\text{EQ. 28})$$

Substitution of Equation 28 and application of the OCP condition in Equation 24 gives Equation 29:

$$R_i = \frac{5}{4} \times \frac{R_{\text{sen}} \times I_{o\max}}{N \times I_{\text{droopmax}}} \quad (\text{EQ. 29})$$

Where  $I_{o\max}$  is the full load current and  $I_{\text{droopmax}}$  is the corresponding droop current. For example, given  $N = 2$ ,  $R_{\text{sen}} = 1\text{m}\Omega$ ,  $I_{o\max} = 50\text{A}$  and  $I_{\text{droopmax}} = 45\mu\text{A}$ , Equation 29 gives  $R_i = 694\Omega$ .

## Load Line Slope

See Figure 14 for load line implementation.

For inductor DCR sensing, substitution of Equation 23 into Equation 3 gives the load line slope expression in Equation 30:

$$\text{LL} = \frac{V_{\text{droop}}}{I_o} = \frac{5}{4} \times \frac{R_{\text{droop}}}{R_i} \times \frac{R_{\text{ntcnet}}}{R_{\text{ntcnet}} + \frac{R_{\text{sum}}}{N}} \times \frac{\text{DCR}}{N} \quad (\text{EQ. 30})$$

For resistor sensing, substitution of Equation 27 into Equation 3 gives the load line slope expression in Equation 31:

$$\text{LL} = \frac{V_{\text{droop}}}{I_o} = \frac{5}{4} \times \frac{R_{\text{sen}} \times R_{\text{droop}}}{N \times R_i} \quad (\text{EQ. 31})$$

Substitution of Equation 24 and rewriting Equation 30, or substitution of Equation 28 and rewriting Equation 31, gives the same result as in Equation 32:

$$R_{\text{droop}} = \frac{I_o}{I_{\text{droop}}} \times \text{LL} \quad (\text{EQ. 32})$$

One can use the full-load condition to calculate  $R_{\text{droop}}$ . For example, given  $I_{o\max} = 50\text{A}$ ,  $I_{\text{droopmax}} = 45\mu\text{A}$  and  $\text{LL} = 2.1\text{m}\Omega$ , Equation 32 gives  $R_{\text{droop}} = 2.33\text{k}\Omega$ .

It is recommended to start with the  $R_{\text{droop}}$  value calculated by Equation 32 and fine-tune it on the actual board to get accurate load line slope. One should record the output voltage readings at no load and at full load for load line slope calculation. Reading the output voltage at lighter load instead of full load will increase the measurement error.

## Compensator

Figure 22 shows the desired load transient response waveforms. Figure 28 shows the equivalent circuit of a voltage regulator (VR) with the droop function. A VR is equivalent to a voltage source (= VID) and output impedance  $Z_{\text{out}}(s)$ . If  $Z_{\text{out}}(s)$  is equal to the load line slope LL, i.e., a constant output impedance, then in the entire frequency range,  $V_o$  will have a square response when  $I_o$  has a square change.

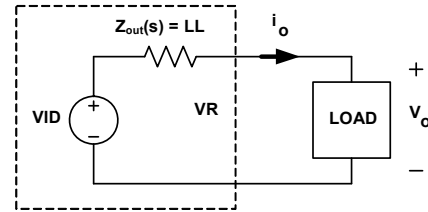

FIGURE 28. VOLTAGE REGULATOR EQUIVALENT CIRCUIT

Intersil provides a Microsoft Excel-based spreadsheet to help design the compensator and the current sensing network so that VR achieves constant output impedance as a stable system.

A VR with active droop function is a dual-loop system consisting of a voltage loop and a droop loop, which is a current loop. However, neither loop alone is sufficient to describe the entire system. The spreadsheet shows two loop gain transfer functions,  $T1(s)$  and  $T2(s)$ , that describe the entire system. Figure 29 conceptually shows  $T1(s)$  measurement set up and Figure 30 conceptually shows  $T2(s)$  measurement set up. The VR senses the inductor current, multiplies it by a gain of the load line slope, adds it on top of the sensed output voltage and then feeds it to the compensator.  $T1$  is measured after the summing node and  $T2$  is measured in the voltage loop before the summing node. The spreadsheet gives both  $T1(s)$  and  $T2(s)$  plots. However, only  $T2(s)$  can actually be measured on an ISL62771 regulator.

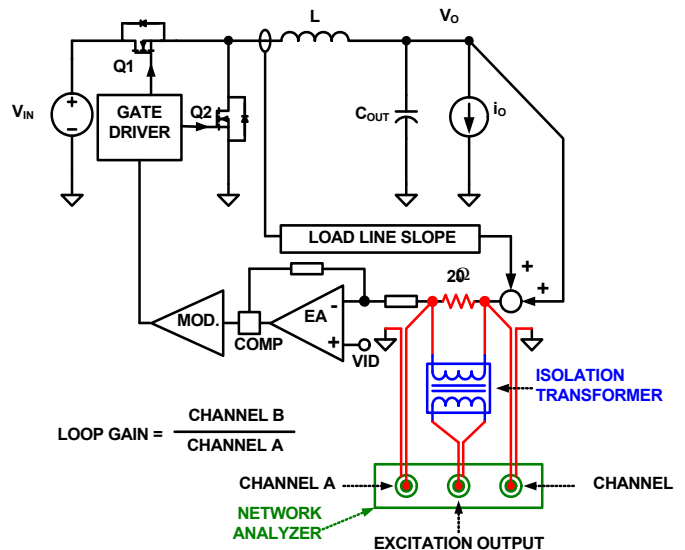

FIGURE 29. LOOP GAIN  $T1(s)$  MEASUREMENT SET UP

$T1(s)$  is the total loop gain of the voltage loop and the droop loop. It always has a higher crossover frequency than  $T2(s)$ , therefore has a higher impact on system stability.

T2(s) is the voltage loop gain with closed droop loop, thus having a higher impact on output voltage response.

Design the compensator to get stable T1(s) and T2(s) with sufficient phase margin and an output impedance equal to or smaller than the load line slope.

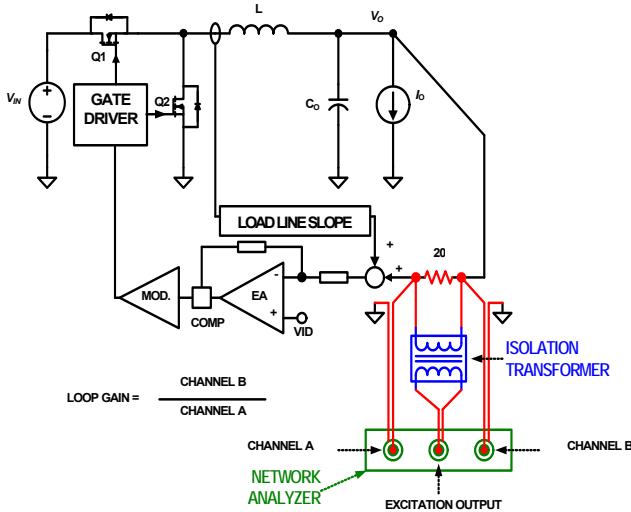

FIGURE 30. LOOP GAIN T2(s) MEASUREMENT SET-UP

## Current Balancing

Refer to [Figure 15](#) through [21](#) for information on current balancing. The ISL62771 achieves current balancing through matching the ISEN pin voltages.  $R_{isen}$  and  $C_{isen}$  form filters to remove the switching ripple of the phase node voltages. It is recommended to use a rather long  $R_{isen}$ ,  $C_{isen}$  time constant, such that the ISEN voltages have minimal ripple and represent the DC current flowing through the inductors. Recommended values are  $R_s = 10k\Omega$  and  $C_s = 0.22\mu F$ .

## Thermal Monitor Component Selection

The ISL62771 features two pins, NTC and NTC\_NB, which are used to monitor motherboard temperature and alert the AMD CPU if a thermal issue arises. The basic function of this circuitry is outlined in the [“Thermal Monitor \[NTC, NTC\\_NB\]” on page 24](#). [Figure 31](#) shows the basic configuration of the NTC resistor,  $R_{NTC}$  and offset resistor,  $R_s$ , used to generate the warning and shutdown voltages at the NTC pin.

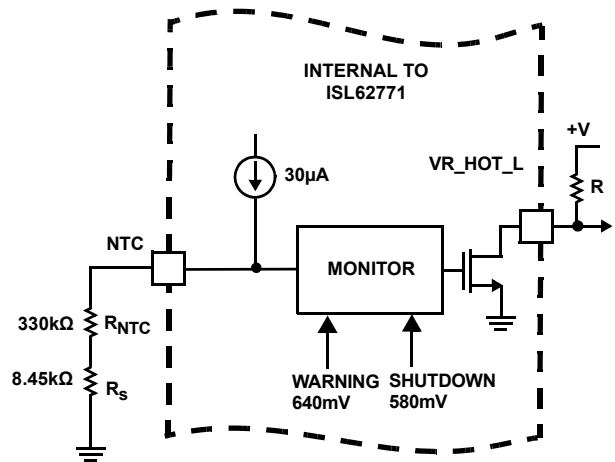

FIGURE 31. THERMAL MONITOR FEATURE OF THE ISL62771

As the board temperature rises, the NTC thermistor resistance decreases and the voltage at the NTC pin drops. When the voltage on the NTC pin drops below the thermal warning threshold of 0.64V, then VR\_HOT\_L is pulled low. When the AMD CPU detects VR\_HOT\_L has gone low, it will begin throttling back load current on both outputs to reduce the board temperature.

If the board temperature continues to rise, the NTC thermistor resistance will drop further and the voltage at the NTC pin could drop below the thermal shutdown threshold of 0.58V. Once this threshold is reached, the ISL62771 shuts down both Core and Northbridge VRs indicating a thermal fault has occurred prior to the thermal fault counter triggering a fault.

Selection of the NTC thermistor can vary depending on how the resistor network is configured. The equivalent resistance at the typical thermal warning threshold voltage of 0.64V is defined in [Equation 33](#).

$$\frac{0.64V}{30\mu A} = 21.3k\Omega \quad (EQ. 33)$$

The equivalent resistance at the typical thermal shutdown threshold voltage of 0.58V required to shutdown both outputs is defined in [Equation 34](#).

$$\frac{0.58V}{30\mu A} = 19.3k\Omega \quad (EQ. 34)$$

The NTC thermistor value correlates to the resistance change between the warning and shutdown thresholds and the required temperature change. If the warning level is designed to occur at a board temperature of +100°C and the thermal shutdown level at a board temperature of +105°C, then the resistance change of the thermistor can be calculated. For example, a Panasonic NTC thermistor with B = 4700 has a resistance ratio of 0.03939 of its nominal value at +100°C and 0.03308 of its nominal value at +105°C. Taking the required resistance change between the thermal warning threshold and the shutdown threshold and dividing it by the change in resistance ratio of the NTC thermistor at the two temperatures of interest, the required resistance of the NTC is defined in [Equation 35](#).

$$\frac{(21.3k\Omega - 19.3k\Omega)}{(0.03939 - 0.03308)} = 317k\Omega \quad (EQ. 35)$$

The closest standard thermistor to the value calculated with  $B = 4700$  is  $330k\Omega$ . The NTC thermistor part number is ERTJOEV334J. The actual resistance change of this standard thermistor value between the warning threshold and the shutdown threshold is calculated in [Equation 36](#).

$$(330k\Omega \cdot 0.03939) - (330k\Omega \cdot 0.03308) = 2.082k\Omega \quad (\text{EQ. 36})$$

Since the NTC thermistor resistance at  $+105^\circ\text{C}$  is less than the required resistance from [Equation 34](#), additional resistance in series with the thermistor is required to make up the difference. A standard resistor, 1% tolerance, added in series with the thermistor will increase the voltage seen at the NTC pin. The additional resistance required is calculated in [Equation 37](#).

$$19.3k\Omega - 10.916k\Omega = 8.384k\Omega \quad (\text{EQ. 37})$$

The closest standard 1% tolerance resistor is  $8.45k\Omega$ .

The NTC thermistor is placed in a hot spot on the board, typically near the upper MOSFET of Channel 1 of the respective output. The standard resistor is placed next to the controller.

## Layout Guidelines

### PCB Layout Considerations

#### POWER AND SIGNAL LAYERS PLACEMENT ON THE PCB

As a general rule, power layers should be close together, either on the top or bottom of the board, with the weak analog or logic signal layers on the opposite side of the board. The ground-plane layer should be adjacent to the signal layer to provide shielding.

#### COMPONENT PLACEMENT

There are two sets of critical components in a DC/DC converter; the power components and the small signal components. The power components are the most critical because they switch large amount of energy. The small signal components connect to sensitive nodes or supply critical bypassing current and signal coupling.

The power components should be placed first and these include MOSFETs, input and output capacitors and the inductor. It is important to have a symmetrical layout for each power train, preferably with the controller located equidistant from each power train. Symmetrical layout allows heat to be dissipated equally across all power trains. Keeping the distance between the power train and the control IC short helps keep the gate drive traces short. These drive signals include the LGATE, UGATE, PGND, PHASE and BOOT.

When placing MOSFETs, try to keep the source of the upper MOSFETs and the drain of the lower MOSFETs as close as thermally possible (see [Figure 32](#)). Input high-frequency capacitors should be placed close to the drain of the upper MOSFETs and the source of the lower MOSFETs. Place the output inductor and output capacitors between the MOSFETs and the load. High-frequency output decoupling capacitors (ceramic) should be placed as close as possible to the decoupling target (microprocessor), making use of the shortest connection paths to any internal planes. Place the components in such a way that the area under the IC has less noise traces with high  $dV/dt$  and  $di/dt$ , such as gate signals and phase node signals.

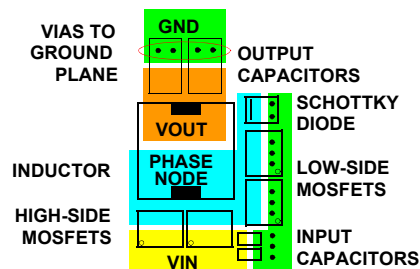

FIGURE 32. TYPICAL POWER COMPONENT PLACEMENT

[Table 13](#) shows layout considerations for the ISL62771 controller by pin.



# ISL62771

**TABLE 13. LAYOUT CONSIDERATIONS FOR THE ISL62771 CONTROLLER**

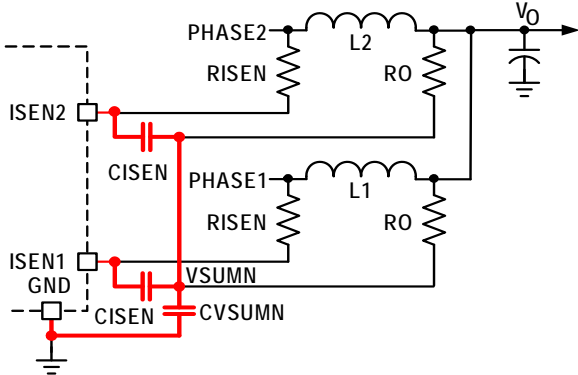
ISL62771 PIN	SYMBOL	LAYOUT GUIDELINES
BOTTOM PAD	GND	Connect this ground pad to the ground plane through a low impedance path. A minimum of 5 vias are recommended to connect this pad to the internal ground plane layers of the PCB.
1	NTC_NB	The NTC thermistor must be placed close to the thermal source that is monitored to determine Northbridge thermal throttling. Placement at the hottest spot of the Northbridge VR is recommended. Additional standard resistors in the resistor network on this pin should be placed near the IC.
2	IMON_NB	Place the IMON_NB resistor close to this pin and make/keep a tight GND connection.
3	SVC	Use good signal integrity practices and follow AMD recommendations.
4	VR_HOT_L	Follow AMD recommendations. Placement of the pull-up resistor near the IC is recommended.
5	SVD	Use good signal integrity practices and follow AMD recommendations.
6	VDDIO	Use good signal integrity practices and follow AMD recommendations.
7	SVT	Use good signal integrity practices and follow AMD recommendations.
8	ENABLE	Use good signal integrity practices.
9	PWROK	Use good signal integrity practices and follow AMD recommendations.
10	IMON	Place the IMON resistor close to this pin and make/keep a tight GND connection.
11	NTC	The NTC thermistor must be placed close to the thermal source that is monitored to determine Core thermal throttling. Placement at the hottest spot of the Core VR is recommended. Additional standard resistors in the resistor network on this pin should be placed near the IC.
12	ISEN2	<p>Each ISEN pin has a capacitor (<math>C_{isen}</math>) decoupling it to VSUMN and then through another capacitor (<math>C_{vsumn}</math>) to GND. Place Cisen capacitors as close as possible to the controller and keep the following loops small:</p> <ol style="list-style-type: none"> <li>Any ISEN pin to another ISEN pin</li> <li>Any ISEN pin to GND</li> </ol> <p>The red traces in the following drawing show the loops to be minimized.</p> 
13	ISEN1	

# ISL62771

**TABLE 13. LAYOUT CONSIDERATIONS FOR THE ISL62771 CONTROLLER (Continued)**

ISL62771 PIN	SYMBOL	LAYOUT GUIDELINES
14	ISUMP	Place the current sensing circuit in general proximity of the controller.
15	ISUMN	<p>Place capacitor Cn very close to the controller.</p> <p>Place the NTC thermistor next to Core VR Channel 1 inductor so it senses the inductor temperature correctly. Each phase of the power stage sends a pair of VSUMP and VSUMN signals to the controller. Run these two signals traces in parallel fashion with decent width (&gt;20mil).</p> <p><b>IMPORTANT:</b> Sense the inductor current by routing the sensing circuit to the inductor pads. If possible, route the traces on a different layer from the inductor pad layer and use vias to connect the traces to the center of the pads. If no via is allowed on the pad, consider routing the traces into the pads from the inside of the inductor. The following drawings show the two preferred ways of routing current sensing traces.</p> <div style="text-align: center;"> </div>
16	VSEN	Place the filter on these pins in close proximity to the controller for good coupling.
17	RTN	
18	FB	
19	COMP	Place the compensation components in general proximity of the controller.
20	PGOOD	No special consideration.
21	BOOT1	Use a wide trace width (>30mil). Avoid routing any sensitive analog signal traces close to or crossing over this trace.
22	UGATE1	These two signals should be routed together in parallel. Each trace should have sufficient width (>30mil). Avoid routing these signals near sensitive analog signal traces or crossing over them. Routing PHASE1 to the Core VR Channel 1 high-side MOSFET source pin instead of a general connection to PHASE1 copper is recommended for better performance.
23	PHASE1	
24	LGATE1	Use sufficient trace width (>30mil). Avoid routing this signal near any sensitive analog signal traces or crossing over them.
25	VDD	A high quality, X7R dielectric MLCC capacitor is recommended to decouple this pin to GND. Place the capacitor in close proximity to the pin with the filter resistor nearby the IC.
26	VDDP	A high quality, X7R dielectric MLCC capacitor is recommended to decouple this pin to GND. Place the capacitor in close proximity to the pin.
27	LGATE2	Use sufficient trace width (>30mil). Avoid routing this signal near any sensitive analog signal traces or crossing over them.
28	PHASE2	These two signals should be routed together in parallel. Each trace should have sufficient width (>30mil). Avoid routing these signals near sensitive analog signal traces or crossing over them. Routing PHASE2 to the Core VR Channel 2 high-side MOSFET source pin instead of a general connection to PHASE2 copper is recommended for better performance.
29	UGATE2	
30	BOOT2	Use a wide trace width (>30mil). Avoid routing any sensitive analog signal traces close to or crossing over this trace.
31	BOOT_NB	Use a wide trace width (>30mil). Avoid routing any sensitive analog signal traces close to or crossing over this trace.
32	UGATE_NB	These two signals should be routed together in parallel. Each trace should have sufficient width (>30mil). Avoid routing these signals near sensitive analog signal traces or crossing over them. Routing PHASE_NB to the Northbridge VR high-side MOSFET source pin instead of a general connection to PHASE_NB copper is recommended for better performance.
33	PHASE_NB	
34	LGATE_NB	Use sufficient trace width (>30mil). Avoid routing this signal near any sensitive analog signal traces or crossing over them.



# ISL62771

TABLE 13. LAYOUT CONSIDERATIONS FOR THE ISL62771 CONTROLLER (Continued)

ISL62771 PIN	SYMBOL	LAYOUT GUIDELINES
35	PGOOD_NB	No special consideration.
36	COMP_NB	Place the compensation components in general proximity of the controller.
37	FB_NB	
38	VSEN_NB	Place the filter on this pin in close proximity to the controller for good coupling.
39	ISUMN_NB	Place the current sensing circuit in general proximity of the controller.
40	ISUMP_NB	<p>Place capacitor Cn very close to the controller.</p> <p>Place the NTC thermistor next to Northbridge VR Channel 1 inductor so it senses the inductor temperature correctly. Each phase of the power stage sends a pair of VSUMP and VSUMN signals to the controller. Run these two signals traces in parallel fashion with decent width (&gt;20mil).</p> <p><b>IMPORTANT:</b> Sense the inductor current by routing the sensing circuit to the inductor pads. If possible, route the traces on a different layer from the inductor pad layer and use vias to connect the traces to the center of the pads. If no via is allowed on the pad, consider routing the traces into the pads from the inside of the inductor. The following drawings show the two preferred ways of routing current sensing traces.</p> <div style="text-align: center;"> </div>

## Revision History

The revision history provided is for informational purposes only and is believed to be accurate, but not warranted. Please go to web to make sure you have the latest revision.

DATE	REVISION	CHANGE
March 25, 2015	FN8321.3	On page 1 under Features, added "SVC Frequency Range 100kHz to 20MHz" below "Supports AMD SVI 2.0 serial data bus interface" Electrical Spec Table On page 11: "LOGIC THRESHOLDS" section, added "SVC Frequency Range" with limits of 0.1MHz to 20MHz. Updated the L40.5x5 Package Outline Drawing on page 35 to the latest revision: Rev 1 to Rev 2 changes are by adding tolerance +/- values to Top view and Side View.
September 12, 2013	FN8321.2	Ordering information table on page 9: Changed IRTZ part temperature from -40 °C to +85 °C to -40 °C to +100 °C. Page 14, Channel Configuration Section, removed "as will connecting ISEN1_NB to +5V will disable the Northbridge VR output." Changed temperature -40 °C to +85 °C to -40 °C to +100 °C throughout the datasheet.
December 18, 2012	FN8321.1	Changed AGND symbols to GND symbols in Figures 3 thru 5 and Pin 12/13 drawing in the Layout Guidelines table. The IC has a single GND connection which all signals are referenced.
November 19, 2012	FN8321.1	Typo on page 9 in the pin description for COMP_NB pin. Changed "slew rate" to "switching frequency". The part description in all other places indicated that the slew rate is fixed and the switching frequency is set by the COMP_NB resistor. Corrected part marking in "Ordering Information" on page 9.
June 13, 2012	FN8321.0	Initial Release

## About Intersil

Intersil Corporation is a leading provider of innovative power management and precision analog solutions. The company's products address some of the largest markets within the industrial and infrastructure, mobile computing and high-end consumer markets.

For the most updated datasheet, application notes, related documentation and related parts, please see the respective product information page found at [www.intersil.com](http://www.intersil.com).

You may report errors or suggestions for improving this datasheet by visiting [www.intersil.com/ask](http://www.intersil.com/ask).

Reliability reports are also available from our website at [www.intersil.com/support](http://www.intersil.com/support)

For additional products, see [www.intersil.com/en/products.html](http://www.intersil.com/en/products.html)

Intersil products are manufactured, assembled and tested utilizing ISO9001 quality systems as noted in the quality certifications found at [www.intersil.com/en/support/qualandreliability.html](http://www.intersil.com/en/support/qualandreliability.html)

*Intersil products are sold by description only. Intersil Corporation reserves the right to make changes in circuit design, software and/or specifications at any time without notice. Accordingly, the reader is cautioned to verify that data sheets are current before placing orders. Information furnished by Intersil is believed to be accurate and reliable. However, no responsibility is assumed by Intersil or its subsidiaries for its use; nor for any infringements of patents or other rights of third parties which may result from its use. No license is granted by implication or otherwise under any patent or patent rights of Intersil or its subsidiaries.*

For information regarding Intersil Corporation and its products, see [www.intersil.com](http://www.intersil.com)

# Package Outline Drawing

## L40.5x5

40 LEAD THIN QUAD FLAT NO-LEAD PLASTIC PACKAGE

Rev 2, 7/14

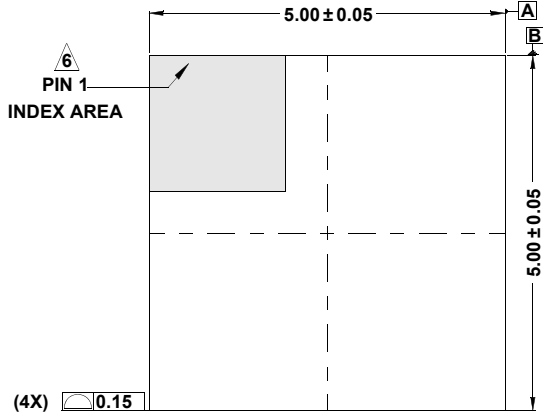

TOP VIEW

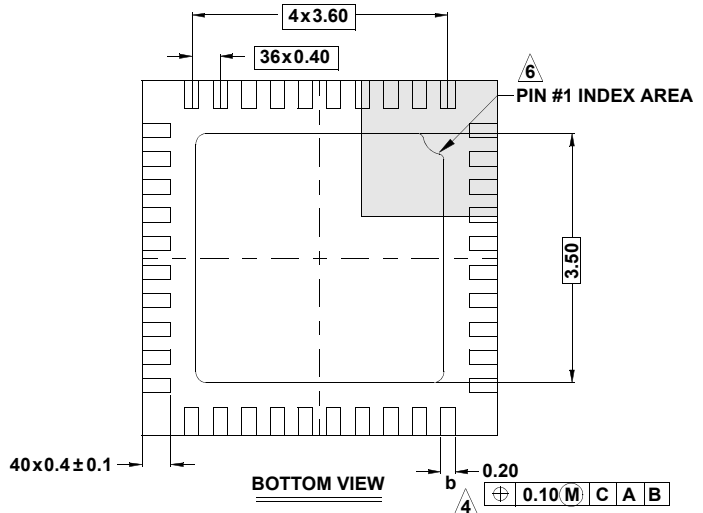

BOTTOM VIEW

PACKAGE OUTLINE

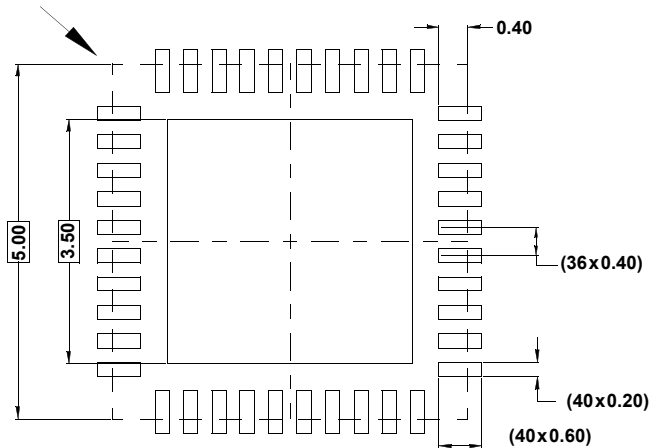

TYPICAL RECOMMENDED LAND PATTERN

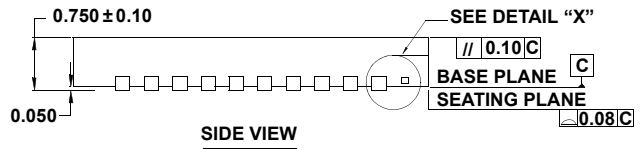

SIDE VIEW

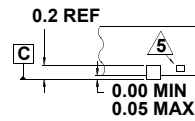

DETAIL "X"

NOTES:

1. Dimensions are in millimeters.  
Dimensions in ( ) for Reference Only.
2. Dimensioning and tolerancing conform to AMSE Y14.5m-1994.
3. Unless otherwise specified, tolerance: Decimal  $\pm 0.05$
4. Dimension b applies to the metallized terminal and is measured between 0.15mm and 0.27mm from the terminal tip.
5. Tiebar shown (if present) is a non-functional feature.
6. The configuration of the pin #1 identifier is optional, but must be located within the zone indicated. The pin #1 identifier may be either a mold or mark feature.
7. JEDEC reference drawing: MO-220WHHE-1

# Mouser Electronics

Authorized Distributor

Click to View Pricing, Inventory, Delivery & Lifecycle Information:

[Intersil:](#)

[ISL62771IRTZ-T](#) [ISL62771HRTZ](#) [ISL62771HRTZ-T](#) [ISL62771IRTZ](#)